

Standalone Linear Li-Ion Charger with Thermal Regulation

General Description

The EMC5040 is a complete linear charger for single cell lithium-ion batteries. With small TDFN-10 package and few external components, EMC5040 is well suited for portable applications. In addition, the EMC5040 is specifically designed to work within USB power specifications.

No external sense resistor and blocking diode are required. Charging current can be programmed externally with a single resistor. The built-in thermal regulation facilitates charging with maximum power without risk of overheating.

The EMC5040 always preconditions the battery with 1/10 of the programmed charge current at the beginning of a charge cycle, after it verifies that the battery can be fast-charged. The EMC5040 automatically terminates the charge cycle when the charge current drops to 1/10th the programmed value after the final float voltage is reached.

The EMC5040 features 13.5V maximum rating voltage for AC adapter, and it provides the charge current up to 1.2A. Other features include battery temperature monitoring, reverse current protection, shutdown mode, charging current monitor, under voltage lockout, automatic recharge and status indicator.

Features

- Programmable charge current up to 1.2A
- No MOSFET, sense resistor or blocking diode required
- Complete linear charger in TDFN-10 for single cell li-ion batteries
- Thermal regulation maximizes charge rate without risk of overheating
- Thermistor input for temperature qualified charging
- Charges single cell Li-ion batteries directly from USB port.
- Preset 4.2V charge voltage with $\pm 1\%$ accuracy
- Automatic recharge
- Charge status indicator
- C/10 charge termination
- Battery reverse leakage current less than 1uA

Applications

- Wireless handsets
- Hand-held instruments
- Portable information appliances

Typical Application Circuit

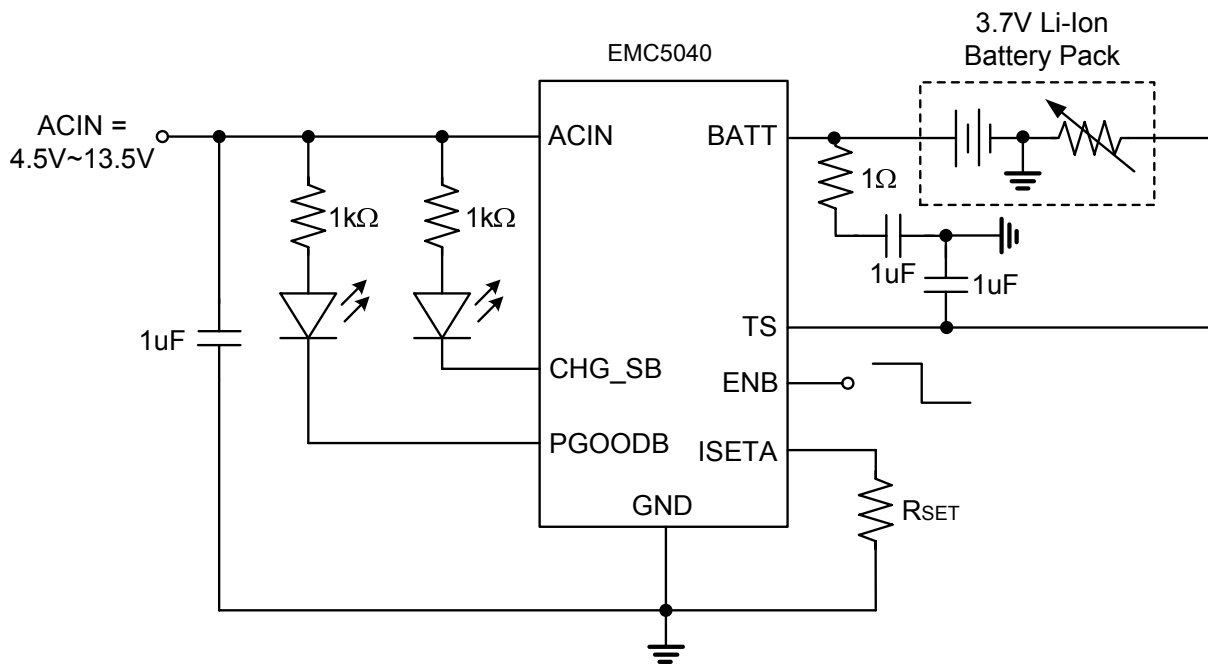

Complete Charger Cycle

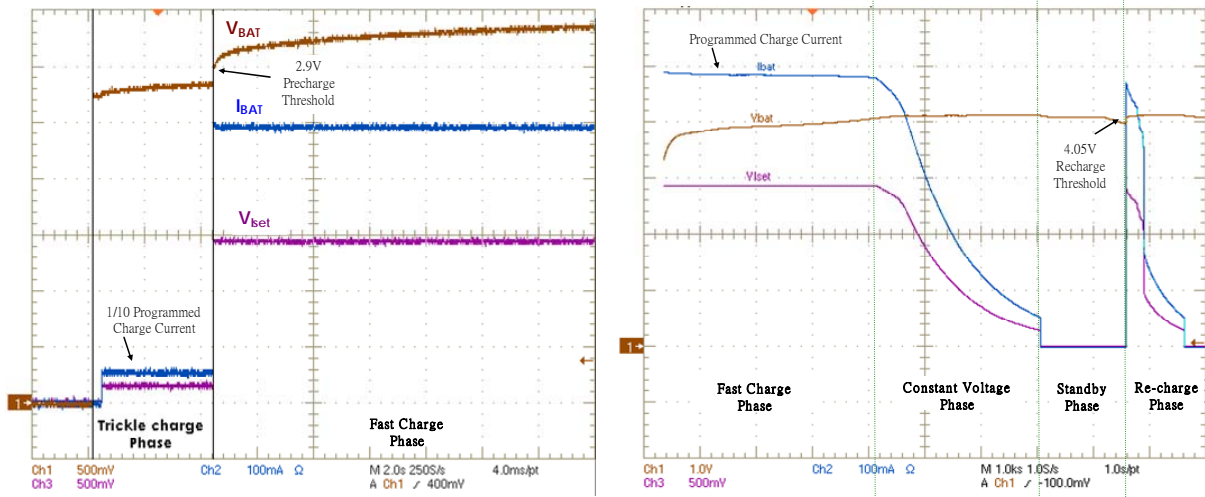

Connection Diagrams

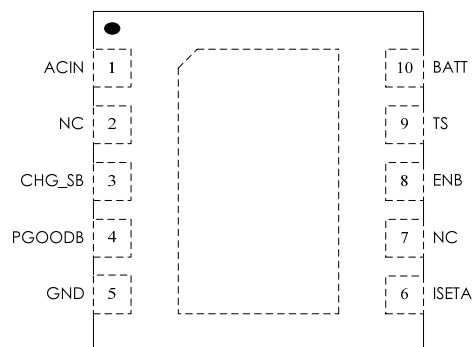

Top View

Order information

EMC5040-42FF10NRR
 42 Output voltage
 FF10 TDFN-10 Package
 NRR RoHS & Halogen free package
 Rating: -40 to 85°C
 Package in Tape & Reel

Order, Marking & Packing Information

Package	Product ID.	Marking	Packing
TDFN-10	EMC5040-42FF10NRR		Tape & Reel 5Kpcs

Pin Functions

Name	TDFN-10	Function
ACIN	1	Positive Input Supply Voltage. Provides power to the charger. ACIN can range from 4.5V to 6.5V and should be bypassed with at least a 1 μ F capacitor. When ACIN drops to within 30mV above the BATT pin voltage, the EMC5040 enters shutdown mode, dropping I _{BATT} to less than 1 μ A.
NC	2	Not connected.
CHG_SB	3	Open-Drain Charge Status Output. An internal N-channel MOSFET connects CHG_SB pin to ground when the battery is charging. After the charge cycle is completed, the internal N-channel MOSFET is replaced by a weak pull-down of approximately 25 μ A, indicating an "AC present" condition. When the EMC5040 detects an under voltage lockout condition, CHG_SB is forced high impedance.
PGOODB	4	Open-Drain Battery Power Good Output. An internal N-channel MOSFET connects PGOODB pin to ground when ACIN is over 4.2V. PGOODB is forced low during normal operation.
GND	5	Ground.
ISETA	6	Charge Current Program, Charge Current Monitor and Shutdown Pin. The charge current is programmed by connecting a 1% resistor, R _{SET} , to ground. When charging in constant-current mode, this pin serves to 1.5V. In all modes, the voltage on this pin can be used to measure the charge current using the following formula: $I_{BATT} = (V_{SET} / R_{SET}) * 500$ The ISETA pin can also be used to shutdown the charger. Disconnecting the program resistor from ground allows a 1 μ A current to pull the ISETA pin high. When it reaches the 2.15V shutdown threshold voltage, the charger enters shutdown mode. This pin is also clamped to approximately 2.5V. Reconnecting R _{SET} to ground will return the charger to normal operation. The ISETA pin must not be directly shorted to ground at any condition.
NC	7	Not connected.
ENB	8	Charge Enable Input (active low). This pin is weakly pulled low internally.
TS	9	TS pin is the input for an external NTC thermistor. When the TS pin voltage is out of the window, determined by the V _{TMIN} and V _{TMAX} , the EMC5040 stops charging and indicates a fault condition.
BATT	10	Charge Current Output and battery voltage feedback. This pin provides charge current to the battery and regulates the final float voltage to 4.2V. An internal precision resistor divider from this pin sets the float voltage which is disconnected in shutdown mode.