





Chapter 3

Cooling, heating and air conditioning systems

Contents

| | | | |
|--|----|--|----|
| Air conditioning system - maintenance | 16 | General information and precautions | 1 |
| Coolant low level warning switch - removal and refitting | 6 | Heater blower motor - removal and refitting | 13 |
| Coolant pump (BX and BX 14) - removal and refitting | 9 | Heater control panel (later models) - removal and refitting | 15 |
| Coolant pump (BX 16 and BX 19) - removal and refitting | 10 | Heater matrix - removal and refitting | 14 |
| Coolant temperature switch - removal and refitting | 7 | Heater unit (air conditioned models) - removal and refitting | 12 |
| Cooling fan - removal and refitting | 4 | Heater unit (non air conditioned models) - removal and refitting | 11 |
| Cooling fan thermal switch - removal and refitting | 5 | Radiator - removal, inspection, cleaning and refitting | 3 |
| Cooling system - draining, flushing and filling | 2 | Thermostat - removal, testing and refitting | 8 |

Degrees of difficulty

| | | | | | | | | | |
|--|---|---|---|---|---|--|---|---|---|
| Easy , suitable for novice with little experience |  | Fairly easy , suitable for beginner with some experience |  | Fairly difficult , suitable for competent DIY mechanic |  | Difficult , suitable for experienced DIY mechanic |  | Very difficult , suitable for expert DIY or professional |  |
|--|---|---|---|---|---|--|---|---|---|

Specifications

For engine to model applications refer to Chapter 2

System

| | |
|------------------------------------|--|
| Type | Pressurised, front mounted radiator (with integral header tank), coolant pump and thermostat. Electric cooling fan |
| Capacity (including heater): | |
| 150 engine | 6.5 litres (11.4 Imp pints) |
| 171 and 159 engines | 6.5 to 7.0 litres (11.4 to 12.3 Imp pints) |
| K1G engine | 6.5 litres (11.4 Imp pints) |
| D6A, D6C and D6D engines | 7.1 litres (12.5 Imp pints) |

Thermostat

| | |
|----------------------------|----------------|
| Travel (minimum) | 7.5 mm |
| Opening temperature: | |
| 150 and 171 engines: | |
| Starts to open | 82°C (180°F) |
| Fully open | 93°C (200°F) |
| 159 engine: | |
| Starts to open | 79°C (174°F) |
| Fully open | 82°C (180° F) |
| K1G engine: | |
| Starts to open | 88°C (190°F) |
| Fully open | 102°C (216° F) |
| D6A, D6C and D6D engines: | |
| Starts to open | 79°C (174°F) |
| Fully open | 82°C (180° F) |

Cooling fan

| | |
|---------------------------|-----------------------------|
| Cut-in temperature: | |
| 150 engine | 91° to 96°C (196° to 205°F) |
| 171 engine: | |
| 1st speed | 84° to 90°C (183° to 194°F) |
| 2nd speed | 90° to 96°C (194° to 205°F) |
| 159 engine: | |
| 1st speed | 86° to 90°C (186° to 194°F) |
| 2nd speed | 90° to 94°C (194° to 201°F) |
| K1G engine | 90°C (194°F) |
| D6A, D6C and D6D engines: | |
| 1st speed | 86° to 90°C (186° to 194°F) |
| 2nd speed | 90° to 94°C (194° to 201°F) |

3•2 Cooling, heating and air conditioning systems

Coolant temperature switch

Operational temperatures:

| | |
|--------------------------|-------------------------------|
| 150 engine | 110° to 113°C (230° to 235°F) |
| 159 engine | 105° to 112°C (221° to 233°F) |
| 171 engine: | |
| Yellow connection | 110° to 114°C (230° to 237°F) |
| Blue connection | 103° to 107°C (217° to 224°F) |
| K1G engine | 110°C (230°F) |
| D6A, D6C and D6D engines | 105 to 112°C (221 to 233°F) |

Radiator

| | |
|--------------|-------|
| Cap pressure | 1 bar |
|--------------|-------|

Torque wrench settings

| | Nm | lbf ft |
|----------------------------|----|--------|
| 150 engine | | |
| Coolant pump | 18 | 14 |
| Coolant temperature switch | 45 | 33 |
| Thermostat housing cover | 17 | 13 |
| 171 and 159 engines | | |
| Coolant pump | 15 | 11 |
| Coolant temperature switch | 18 | 14 |
| Coolant housing | 16 | 12 |
| Coolant housing plug | 20 | 15 |
| Thermostat housing cover | 17 | 13 |
| K1G engine | | |
| Coolant pump upper stud | 16 | 12 |
| Coolant pump lower bolt | 8 | 6 |
| Housing inlet elbow | 8 | 6 |
| Housing to block: | | |
| 8 mm bolts | 31 | 22 |
| 10 mm bolts | 51 | 37 |

1 General information and precautions

General information

Cooling system

The cooling system is of the pump-assisted thermal syphon type and is pressurised by means of a pressure valve filler cap. The main components of the system are the radiator, the coolant pump, the thermostat, the cooling fan, the heater and the connecting hoses.

Cold coolant from the bottom of the radiator is pumped into the passages of the cylinder block and head. Heat from the combustion chambers and moving parts of the engine is absorbed by the coolant which is then directed to the upper section of the radiator. The passage of air through the radiator cools the coolant as it passes down through the matrix and the cycle is then repeated.

To accelerate the warming-up process when starting the engine, and thereafter to maintain the correct operating temperature, a thermostat is fitted in the coolant outlet from the engine to the radiator top hose. When the coolant is cold, the thermostat is closed and circulation is limited to the engine coolant passages by means of a bypass route. As coolant temperature rises, the thermostat opens to allow coolant to flow through the radiator.

The system is pressurised to raise the boiling point of the coolant. This allows the engine to achieve its most efficient operating temperature as well as reducing the amount of coolant needed.

Hot coolant is tapped from the system to supply the vehicle heater matrix and also to supply heat to the carburettor and inlet manifold to improve fuel vaporisation.

The cooling fan is driven by an electric motor and this only cuts in above a certain temperature when activated by a coolant temperature sensor switch.

On BX and BX 14 models equipped with the 150 engine, the coolant pump is driven in tandem with the alternator by a drivebelt driven from the crankshaft pulley.

On BX 14 models equipped with the K1G engine, the coolant pump is located at the timing case end of the cylinder block and is driven by the timing belt.

On BX 16 and BX 19 models, the coolant pump is located in the front of the cylinder block at the timing case end and is driven by the timing belt.

On BX 16 and BX 19 models manufactured after July 1985, the cooling system circuit is modified, the main differences being a revised carburettor heating circuit and coolant inlet casing. The opening temperatures for the thermostat, and the temperature switch operating temperatures, are also revised.

Heating and ventilation system

The heater is located centrally under the facia and supplies warm air for interior heating or windscreen demisting. Hot coolant is piped from the engine through a heater matrix and back to the engine when a manually operated valve is opened.

Fresh air inlets are located at the ends of the facia and any stale air from the car interior is exhausted through slots in the tailgate closure recess.

Air conditioning system

Air conditioning is available as an optional extra on some models. To allow for fitting of the system, the engine crankcase is modified to suit and the Weber carburettor fitted with a butterfly opener controlled by an "Elbi" electrovalve which is located underneath the battery tray. A battery of increased capacity is also fitted. The heater system continues to work on the normal principle in conjunction with the cooling system and incorporates its own booster motor.

Precautions

Cooling system maintenance

Do not remove the expansion tank filler cap or disturb any part of the cooling system whilst it is hot, as there is a very great risk of scalding. If the filler cap must be removed before the system is cool, then the pressure in

the system must first be released. Cover the cap with a thick layer of cloth, to avoid scalding, and slowly unscrew the cap until a hissing sound can be heard. When the hissing has stopped, then system pressure is released. Slowly unscrew the cap until it can be removed. If more hissing sounds are heard, wait until they have stopped before unscrewing the cap completely. At all times keep well away from the filler opening.

If the engine is hot, the electric cooling fan may start rotating even if the engine is not running. Be careful to keep hands, hair and loose clothing well clear of the fan when working in the engine compartment.

Antifreeze mixture

Antifreeze mixture is poisonous. Keep it out of reach of children and pets. Never leave antifreeze lying around, it is fatal if ingested.

Do not allow antifreeze to come in contact with your skin or the painted surfaces of the vehicle. Rinse off spills immediately with plenty of water.

Air conditioning refrigerant

Although the refrigerant is not itself toxic, in the presence of a naked flame (or a lighted cigarette) it forms a highly toxic gas. Liquid refrigerant spilled on the skin will cause frostbite. If refrigerant enters the eyes, rinse them with a dilute solution of boric acid and seek medical advice immediately.

In view of the above points, and of the need for specialised equipment for evacuating and recharging the system, any work which requires the disconnection of a refrigerant line must be left to a specialist.

Do not allow refrigerant lines to be exposed to temperatures above 230°F (110°C) - eg. during welding or paint drying operations. Do not operate the air conditioning system if it is known to be short of refrigerant, or further damage may result.

2 Cooling system - draining, flushing and filling



Refer to Chapter 1, Section 32.



3.4b Air inlet duct attached to crosspanel - GTi



3.3 Temperature sensor unit location in radiator

3 Radiator - removal, inspection, cleaning and refitting



Warning: Never work on the cooling system when it is hot. Take care to avoid any possibility of scalding

Removal

- 1 Drain the cooling system.
- 2 Unclip and disconnect the top hose and the smaller expansion return hose from the radiator.
- 3 Disconnect the wiring connections from the radiator temperature sensor unit (see illustration) and, where applicable, the coolant level indicator unit
- 4 Pivot the bonnet stay out of the way, then unscrew and remove the five radiator front crosspanel securing bolts. Remove the crosspanel (see illustration). Note that on GTi models, the crosspanel has the fuel system air inlet duct attached. The inlet duct hose will need to be detached from the panel and moved out of the way (see illustration).
- 5 Carefully lift the radiator out of the engine compartment (see illustration).

Inspection

- 6 Extensive damage should be repaired by a specialist or the unit exchanged for a new or reconditioned radiator. The radiator matrix, header and bottom tanks should be thoroughly examined for signs of damage, deterioration and leakage. Very often, a white



3.5 Lifting radiator out of vehicle



3.4a Undoing radiator retaining bolts

or rusty sediment will have been deposited where a leak has occurred.

Cleaning

7 After inspection, the radiator should be flushed and the matrix and exterior cleaned of dirt and dead flies with a strong jet of water.

Refitting

8 Refitting the radiator is a reversal of the removal procedure, but the following additional points should be noted:

- a) Examine and renew any clips, hoses and rubber mounting washers which have deteriorated
- b) Refill the cooling system

4 Cooling fan - removal and refitting



3

Removal

- 1 Raise and support the bonnet.
- 2 Disconnect the battery earth lead.
- 3 Undo the retaining screws and detach the front grille panel.
- 4 Undo the fan unit retaining bolt (see illustration) at the top and lift out the fan unit sufficiently to detach the wiring connector, then fully remove the fan unit.

Refitting

5 Refit in the reverse order of removal and check for correct operation of the fan on completion.



3.4 Cooling fan retaining bolt

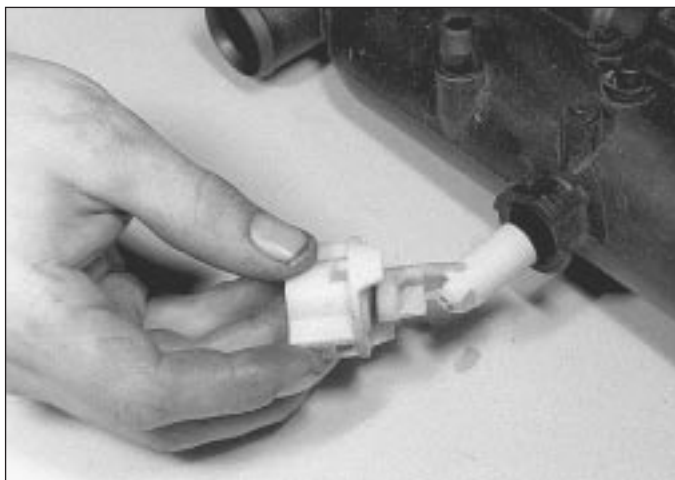

6.3 Coolant low level warning switch removal

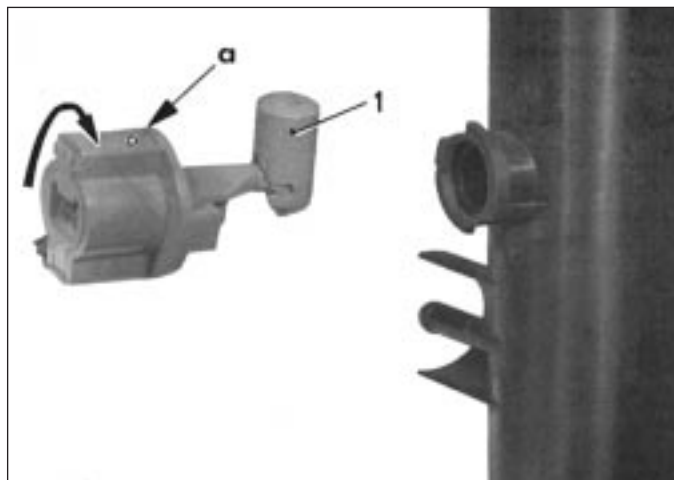

6.4 Coolant low level warning switch showing correct orientation when fitted - mark "a" at top

5 Cooling fan thermal switch - removal and refitting



Removal

- 1 This switch is fitted into the rear face of the radiator bottom section and its purpose is to switch the cooling fan on and off in accordance with the coolant temperature.
- 2 To remove the switch, first drain the coolant from the radiator.
- 3 Disconnect the switch wiring connector then unscrew and remove the switch.

Refitting

- 4 Refit the switch in the reverse order to removal. If the original switch is being refitted, check that the sealing washer is in good condition and renew if necessary.
- 5 Top-up the coolant level on completion then run the engine and check that the cooling fan operates when the engine is warmed up.

6 Coolant low level warning switch - removal and refitting



Removal

- 1 If fitted, this switch is located in the radiator.
- 2 To remove the switch, first partially drain the cooling system.
- 3 Disconnect the switch wiring connector then twist the switch anti-clockwise and withdraw it (see illustration).

Refitting

- 4 Refit the switch in the reverse order to removal but ensure that its orientation is correct with the counterweight to the top (see illustration).

- 5 On completion, top-up and bleed the cooling system.

7 Coolant temperature switch - removal and refitting



Removal

- 1 Where a single switch is fitted, it will be screwed into the cylinder head, adjacent to the thermostat housing.
- 2 Alternatively, where there are two switches fitted, both are screwed into the thermostat housing itself. The switch with the blue lead connector makes the warning lamp blink when the coolant temperature reaches 105°C (221°F) and the switch with the yellow lead connector actuates the warning lamp when the coolant temperature reaches 112°C (233°F) (see illustration).
- 3 It is difficult to test a temperature switch without special equipment and the best method to use if a fault develops is to substitute a new switch, but only after the wiring to the gauge has been thoroughly checked.
- 4 To remove a switch, drain the coolant, disconnect the wiring from the switch and unscrew the switch.



7.2 Coolant temperature switches - BX 16 and BX 19

Refitting

- 5 When refitting a switch, make sure that its seal is in good condition. Do not overtighten the switch.
- 6 Refill the cooling system.
- 7 If a switch is changed and the gauge still does not register, then the gauge should be checked by a competent auto-electrician. Access to the gauge is obtained after removing the instrument panel.

8 Thermostat - removal, testing and refitting



Removal

- 1 The thermostat is located at the engine end of the radiator top hose, under a cover secured to the cylinder head/adaptor. The one exception being on BX 19 GTi 16 valve models, where it is located at the flywheel end of the cylinder block and where its housing incorporates the coolant temperature switch, a sensor for the Motronic engine management system and a bleed screw (see illustrations).
- 2 To remove the thermostat, first partially drain the cooling system and then disconnect the top hose from the thermostat housing outlet.



8.1a Thermostat housing in position - BX 19 GTi 16v



8.1b Thermostat housing dismantled - BX 19 GTi 16v



8.1c Thermostat housing bleed screw (arrowed) - BX 19 GTi 16v



8.3 Thermostat housing cover - BX and BX 14



8.4 The thermostat

3 Unscrew and remove the two retaining bolts and carefully lift the coolant outlet away from the cylinder head/adaptor (see illustration).

4 Extract the thermostat from its recess and remove the old gasket (see illustration).

5 Clean the faces of the cylinder head/adaptor and the mating thermostat cover so that they are free of all traces of gasket and sealant.

Testing

6 To test whether the thermostat is serviceable, suspend it by a piece of string in a pan of water. Heat the water whilst ensuring that the thermostat does not touch the pan. Use a similarly suspended thermometer to check the operating temperatures of the thermostat with reference to the information given in *Specifications*. If the thermostat is faulty it must be renewed.



9.3 Coolant pump hoses



9.5a Coolant pump O-ring seal



9.5b Fitting coolant pump

Refitting

7 Refitting the thermostat is a reversal of the removal procedure, noting the following:

- Use a new thermostat gasket
- Ensure that the mating surfaces of the water outlet and head or manifold are clean and free of excessive corrosion
- Ensure that the thermostat vent pin is positioned upwards to allow air to escape from the system
- Refill the cooling system

9 Coolant pump (BX and BX 14) - removal and refitting



150 engine

- Drain the engine coolant.
- Loosen the drivebelt tension and disengage the belt from the pump pulley.
- Undo the retaining clips and detach the coolant hoses from the pump (see illustration). Unbolt the pump and remove it.
- Any wear in the pump or leakage of coolant at the shaft gland will mean renewal of the pump, as repair is not possible.
- Always renew the O-ring seal before fitting the pump to the cylinder block (see illustrations).
- Tighten the pump bolts to the specified torque.
- Refit and adjust the drivebelt, referring to the information given for the alternator drivebelt.

8 Refill the cooling system.

K1G engine

9 Drain the cooling system.

10 Unbolt and remove the upper and intermediate timing covers, leaving the lower cover in position.

11 Turn the engine clockwise, using a socket on the crankshaft pulley bolt until the small hole in the camshaft sprocket is aligned with the corresponding hole in the cylinder head. Insert a close-fitting twist drill or bolt into the holes.

12 Align the TDC holes in the flywheel and cylinder block rear flange, then insert a further twist drill or long bolt.

13 Loosen the timing belt tensioner roller nut, turn the tensioner clockwise using a screwdriver or square drive in the special hole, then re-tighten the nut.

14 Release the timing belt from the pump sprocket.

15 Unscrew the nut from the right-hand engine mounting.

16 Using a trolley jack and block of wood, lift the right-hand side of the engine as far as possible.

17 Unscrew the nuts and remove the mounting bracket from the pump housing.

18 Disconnect the hoses from the housing, then unbolt the housing from the block. Remove the housing O-ring seal (see illustrations).

19 Unbolt the pump from the housing and remove the pump O-ring (see illustrations). If necessary, similarly remove the inlet elbow.



9.18a Bypass hose connection to coolant pump housing (arrowed)

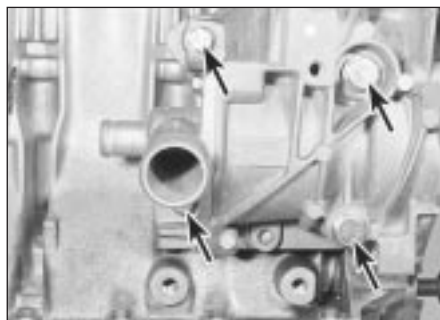

9.18b Coolant pump housing securing bolts (arrowed)



9.18c Coolant pump housing O-ring seal (arrowed)

20 Refitting is a reversal of removal, noting the following points.

- a) Renew the pump and housing O-rings.
- b) Make sure that the housing-to-block location dowels are in position.
- c) Tighten all nuts and bolts to the specified torque.
- d) Refit and tension the timing belt
- e) Refill the cooling system.

10 Coolant pump (BX 16 and BX 19) - removal and refitting



D6C engine

Note: As removal of the pump fitted to this engine requires the timing belt to be removed, it is advisable to read the procedure for timing belt removal and refitting before commencing work

- 1 Drain the cooling system.
- 2 Remove the alternator drivebelt.
- 3 Release the tension on the timing belt and slip the belt from the two camshaft pulleys.
- 4 Remove the camshaft cover, then holding each camshaft using an open-ended spanner on the camshaft flats, undo and remove the bolts and the camshaft sprockets.
- 5 Remove the timing cover upper backplate.
- 6 Unscrew the pump fixing bolts and withdraw the pump (see illustration).
- 7 Refitting is a reversal of removal, noting the following:
 - a) Use a new gasket.



10.6 Withdrawing coolant pump



9.19a Removing coolant pump from housing

- b) Tension the timing belt and drivebelts
- c) Top-up the cooling system

All other engines

- 8 Drain the cooling system.
- 9 Remove the camshaft drivebelt.
- 10 Remove the camshaft drivebelt tensioner.
- 11 Remove the plastic shield, noting the locations of the different types of bolt.
- 12 Remove the five bolts which secure the coolant pump. Remove the pump and recover the gasket (see illustration).
- 13 The pump cannot be repaired and if defective, it must be renewed.
- 14 Refit in the reverse order of removal, noting the following:
 - a) Use a new gasket
 - b) Tighten the securing bolts to the specified torque
 - c) Refit and tension the camshaft timing belt
 - d) Top-up the cooling system



10.12 Coolant pump removal



9.19b Coolant pump O-ring (arrowed)

11 Heater unit (non air conditioned models) - removal and refitting



Early models

- 1 Disconnect the battery earth lead.
- 2 Drain the engine coolant.
- 3 Detach the lower facia panel on the passenger side. It is secured by two screws on the outer end face and a single screw on the other end. Now undo the four screws securing the glovebox lid (see illustration) and remove the lid and lower facia panel.
- 4 Undo and remove the single screw retaining the heater unit from within the glovebox.
- 5 Remove the retaining screws and lower the speaker unit. Detach the wiring connector and remove the unit.

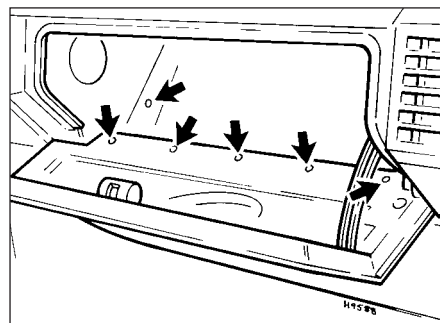

11.3 Remove screws indicated in glovebox



11.6 Heater/ventilation control knob removal



11.8 Heater/ventilation control plate removal



11.10 Remove screws indicated (9 and 10)

6 Withdraw the ashtray and pull free the heater/ventilation control knobs (see illustration).

7 Unscrew the two retaining screws and remove the ashtray support.

8 Remove the heater/ventilation control plate (see illustration).

9 Remove the radio and where applicable, its housing unit.

10 Unscrew and remove the screws from the positions shown (see illustration).

11 Remove the upper and lower retaining screws from the opposite side of the heater/ventilation fascia unit and withdraw the unit. As it is withdrawn, detach the ashtray and heater control light lamps.

12 Remove the cigar lighter and its lamp.

13 If applicable, remove the door lock electronic unit.

14 Unscrew and remove the driver's side lower finishing panel retaining screw.



11.17 Rear passenger compartment heater nozzle



11.19 Remove screws from positions 7, 8 and "a". Steering column lower shroud upper retaining screw positions also shown (6) - Left-hand drive

15 Prise free the blanking plugs (at the front and rear of the gear lever) from the console, then undo the retaining nut (front) and bolt (rear).

16 Remove the two plastic dowels retaining the console to the heater unit. Prise free the gear lever rubber gaiter, pull on the handbrake lever and withdraw the front section of the console.

17 Detach the heater nozzle to the rear passenger compartment (see illustration).

18 Undo the two screws from the top end of the underside of the steering column and release the upper column shroud.

19 Undo and remove the three screws from the positions shown (see illustration), then withdraw the lower driver's side facia, leaving the choke control attached (manual choke models).

20 Detach the heater unit wiring harness connector and plug.

21 Loosen the feed and return coolant hose retaining clips and detach the hoses from the heater unit (see illustration).

22 Carefully detach the bonnet seal rubber, then remove the plastic cover from over the windscreen wiper motor.

23 Undo the two retaining screws and remove the heater air inlet grille.

24 Unscrew and remove the nuts from the positions shown (see illustration).

25 Remove the central directional vent grilles. Insert a screwdriver between the grille and housing to release each grille and withdraw them (see illustration).

26 Using a screwdriver, prise out the vent grille housing by releasing the retaining clips. Remove the vent surround and grille (see illustration).



11.21 Heater flow and return hose connections at bulkhead/heater

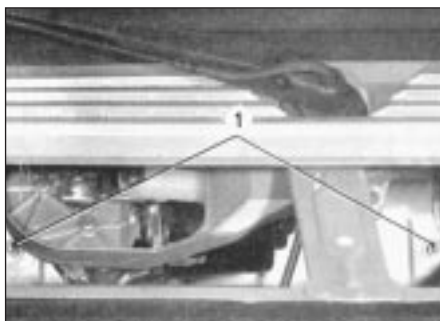

11.24 Remove heater retaining nuts (1)



11.25 Withdraw vent grille . . .



11.26 . . . and grille housing



11.27 Heater coolant drain hose

27 Detach the heater coolant drain pipe from its housing (see illustration).

28 Prise free and detach the heater coolant pipe (feed and return) scuttle seal, then withdraw the heater unit from the passenger side. As it is withdrawn disengage it from the side vent ducts.

29 Refitting is a direct reversal of the removal

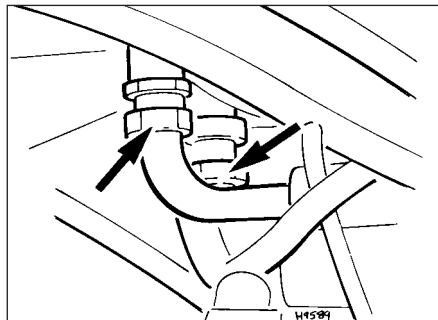

12.4 Air conditioning Freon pipe connections to heater (arrowed)

procedure, noting the following:

- a) Ensure that the heater feed and return hoses are securely connected
- b) Ensure that all wiring connections are correctly and securely made
- c) Check the operation of all items disconnected during removal
- d) Top-up the cooling system

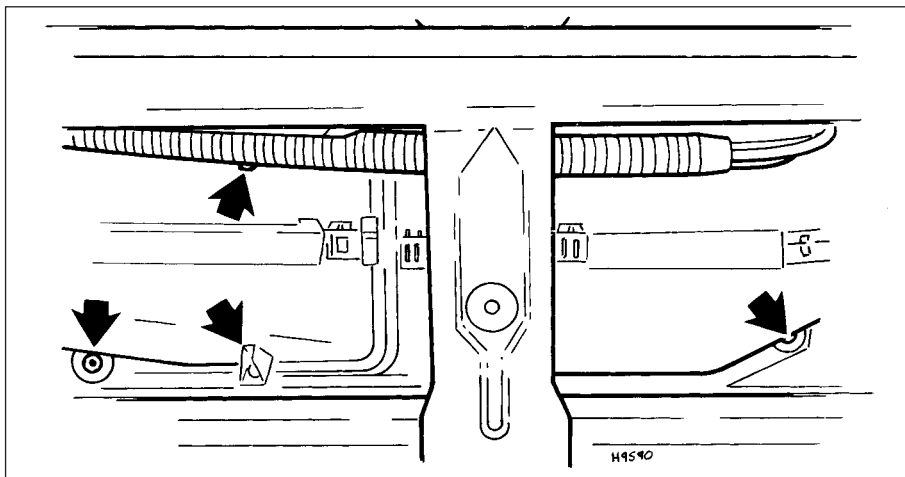

12.5 Additional heater retaining screw locations (arrowed)

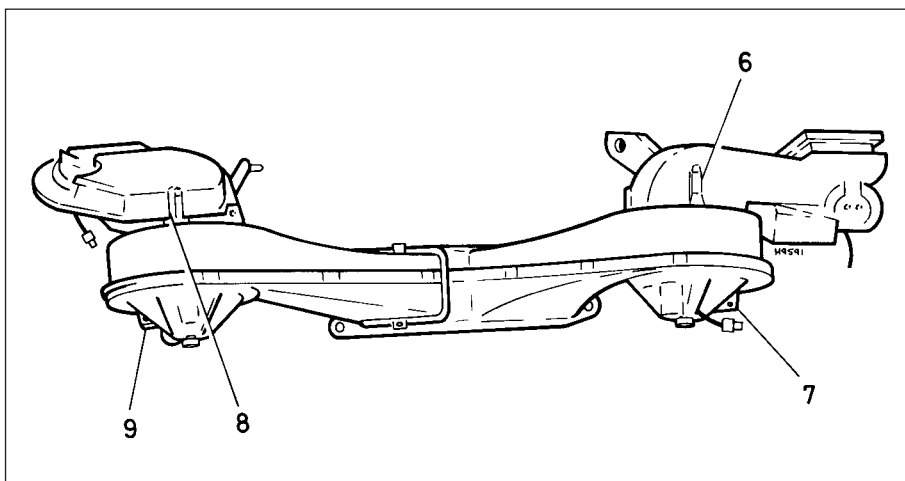

12.6 Remove screws (7 and 9) and clips (6 and 8)

Later models

30 Although the heater unit is much the same as that fitted to earlier models, the controls and the blower motor differ.

31 The blower motor will need to be removed to gain access to the heater unit retaining bolts. Access to the heater motor unit differs, in that the later-type fascia panel and assemblies will have to be removed for access.

32 The heater unit retaining bolt positions are as shown in illustration 11.24.

33 Disconnect the fresh air/heater ducts from the heater unit, then remove the main fascia unit.

34 The heater unit can now be removed in a similar manner to that described for earlier models.

35 Refitting of the heater unit and the associated fittings is a reversal of the removal procedure, noting the points listed in paragraph 29.

12 Heater unit (air conditioned models) - removal and refitting



Warning: Where fitted, the air conditioning system must be depressurised and drained by a Citroën dealer or refrigeration specialist. Do not attempt this yourself

Removal

1 The following procedures closely follow those given for the heater unit fitted to non air conditioned models but the following differences apply.

2 Before starting the removal procedure, have the air conditioning system depressurised and drained by your Citroën dealer or refrigeration specialist. Do not attempt this yourself.

3 Prise free and detach the wiring from the air recirculation switch mounted in the control console.

4 Loosen the retaining nuts and detach the two Freon pipes from the heater unit (engine compartment side) (see illustration). Recover the O-ring seals.

5 Undo the retaining screws shown (see illustration) in addition to those shown in illustration 11.24.

6 Remove the screws at positions 7 and 9, and the clips 6 and 8 (see illustration). Lift the two air inlet pipes for access to the unit retaining screws.

7 Release both the coolant pipe and Freon pipe seals at the bulkhead panel when removing the unit.

Refitting

8 Refit in the reverse order of removal. Ensure that the Freon pipe O-ring seals are located when attaching the pipes.

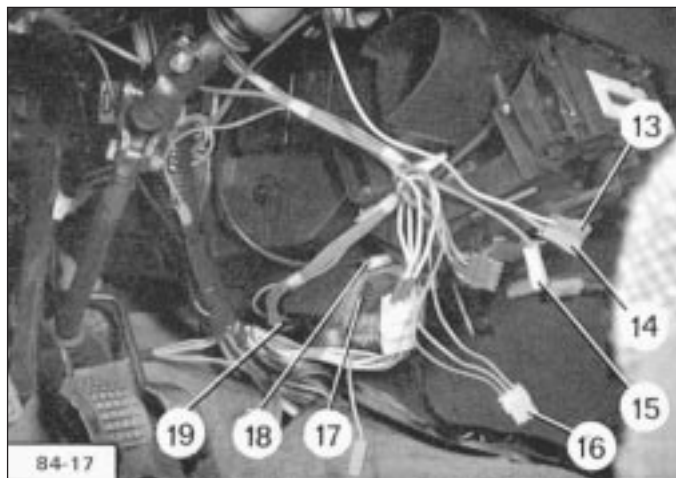

12.9 Heater unit wiring harness connections

- | | |
|-------------------------------------|--|
| 13 Red plug - air blower control | 16 3-way orange connector |
| 14 Blue plug - compressor control | 17 4-way brown connector |
| 15 Yellow plug - air blower control | 18 Green plug - heater unit control lighting |
| | 19 Relay (behind the heater unit) |

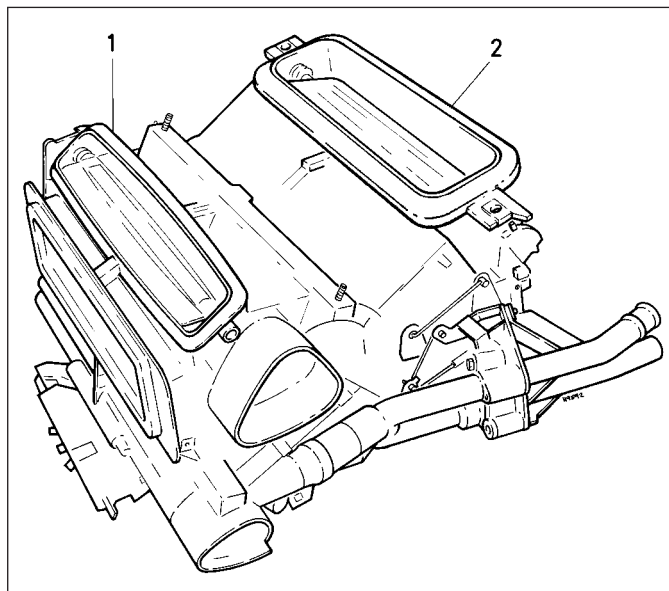

13.2 Heater unit foam gasket location (1 and 2)

9 When reconnecting the heater unit wiring harness, note the connections shown (see illustration).

13 Heater blower motor - removal and refitting



Early models

- 1 Remove the heater unit.
- 2 Carefully prise free and remove the foam gaskets (see illustration).
- 3 Undo the five screws retaining the control bracket, drill out the rivet and retrieve its washer then release the eleven securing clips (see illustration). Separate the housing.

- 4 Remove the five flaps.
- 5 Detach the wiring connectors from the blower motor and then pull the motor out of the housing.
- 6 To remove the grille from the blower motor, undo the two retaining nuts.
- 7 Undo the two screws and withdraw the blower motor from the support.
- 8 Refitting is a reversal of the removal procedure. When refitting the flaps, you will need three "end pieces" manufactured in 5 mm diameter steel wire, 50 mm in length. When the flaps are fitted to their pivot points, operate them to ensure correct fitting then fit the end pieces to the free end of flap numbers 6, 7 and 9 (see illustration).
- 9 When the half housings are reassembled and the clips are in position, the end pieces can be removed.

10 When fitting the 4 mm rivet, insert the plain washer.

Later models

- 11 Disconnect the battery earth lead.
- 12 Remove the windscreen wiper arm and spindle nut.
- 13 The heater blower motor is located in the bulkhead cavity just forward of the windscreen, beneath a plastic cover. Remove the plastic cover by prising free the rubber seal along its front edge and releasing the retaining clips at the rear edge (see illustration).
- 14 Removal of the air inlet grille at the base of the windscreen is advisable, this is secured by plastic clips. Carefully prise free the clips and remove the grille (see illustration).

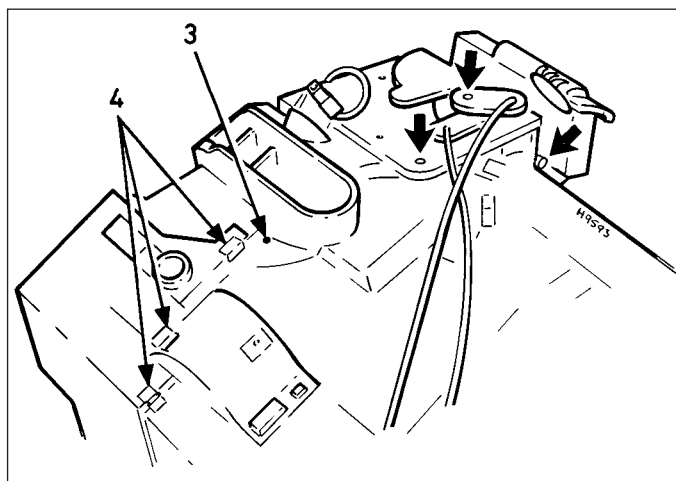

13.3 Remove rivets (3), clips (4) and screws (arrowed)

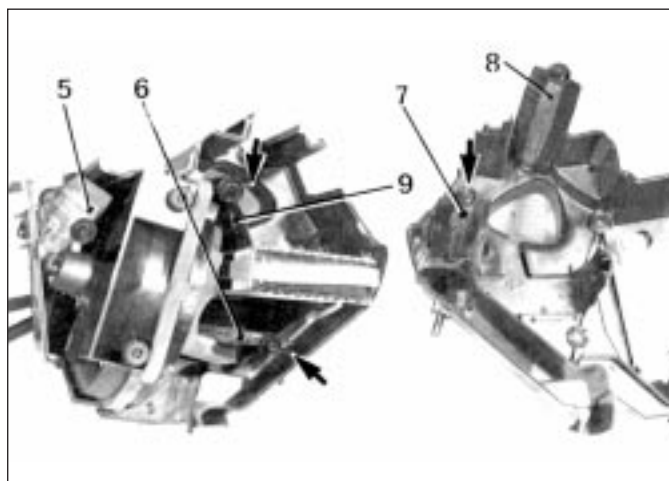

13.8 Heater unit showing flaps (5, 6, 7, 8 and 9). End piece locations arrowed



13.13 Removing plastic cover from heater blower motor



13.14 Removing an air inlet grille securing clip

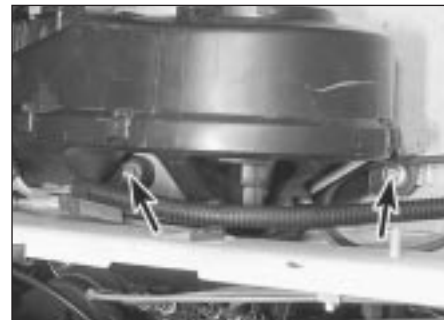

13.15 Blower motor unit support bracket screws (arrowed)

15 Remove the single retaining bolt and the support bracket screws, then disconnect the wiring connectors from the blower motor unit. Carefully lift out and remove the blower motor unit (see illustration).

16 To remove the motor from its housing unit, unclip and separate the half-housings and undo the retaining screws.

17 Refit in the reverse order of removal and check for satisfactory operation.

14 Heater matrix - removal and refitting



Early models

- 1 Drain the cooling system.
- 2 Undo the retaining screws and remove the lower facia finishing panel on the driver's side.
- 3 Undo the four screws retaining the heater tap to the heater matrix (see illustration).
- 4 Undo the two screws retaining the matrix to the heater unit and the tap-to-heater unit screw. Reach up with a socket and extension from underneath for the tap-to-heater screw. As the tap is separated from the heater, allow for a certain amount of coolant spillage by

positioning a rag and/or container underneath it (see illustration).

5 Prise apart the four locating clips and withdraw the matrix from the heater unit. Detach the control links as the matrix is withdrawn.

6 Loosen the hose retaining clips and detach the coolant pipes. Remove the gasket and the tap.

7 Loosen the cable clamp screw, disengage the location clip and then remove the control cable.

8 Refit in the reverse order to removal. During assembly, check that the heater control lever fully opens and closes the tap. Move the location clip position to adjust if necessary.

9 Prior to refitting the lower facia finishing panel, top-up the cooling system then check the heater hoses for any sign of leaks.

Later models

- 10 Drain the cooling system.
- 11 Remove the upper and lower steering column shrouds. These are secured by screws recessed into the lower shroud.
- 12 Unbolt the upper and lower steering column mountings.
- 13 Unbolt and separate the upper-to-lower column universal joint, then withdraw the

upper steering column unit so that it clears the matrix unit. Complete removal of the upper steering column will necessitate detaching the column switch wiring at the harness connectors.

14 The heater matrix is now accessible for withdrawal and can be removed in the same manner described for the earlier variants.

15 Refit in the reverse order of removal.

15 Heater control panel (later models) - removal and refitting



Removal

- 1 Disconnect the battery earth lead.
- 2 Pull free the heater/ventilation control knobs.
- 3 Undo the two retaining screws (see illustration).
- 4 Remove the two ventilation grilles from their apertures above the heater control panel. Pull to release the retaining clips each side and withdraw the outer control panel.
- 5 Disconnect the wiring from the rear face of the cigar lighter.
- 6 The inner control unit is secured by four screws, but it cannot be removed on its own.



14.3 Heater tap (control) unit retaining screws (arrowed)

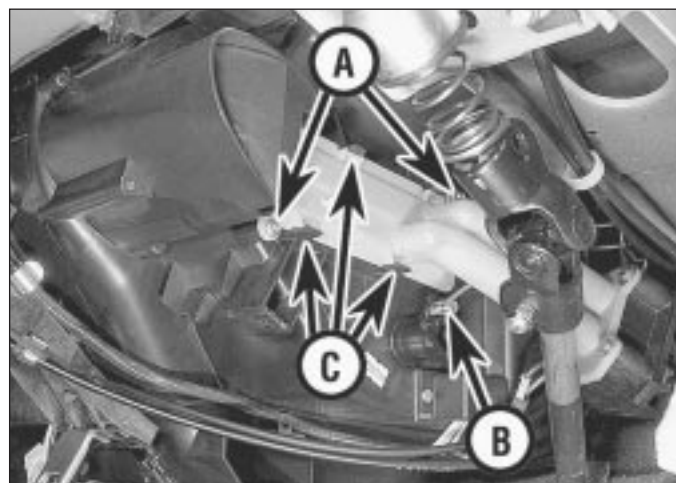

14.4 Heater matrix retaining screws (A) and control link connection (B). Location clips (C) also shown

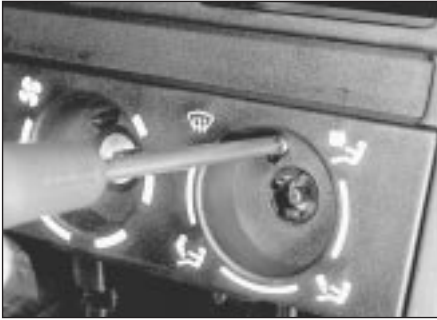

15.3 Removing a heater/ventilation control panel retaining screw

Either remove it together with the heater unit, or detach the controls at the heater and withdraw the control unit (see illustration).

Refitting

7 Refit in the reverse order of removal, and check for satisfactory operation.



15.6 Withdrawing the heater control unit

2 To allow for fitting of the system the engine crankcase is modified to suit and the Weber carburettor fitted with a butterfly opener controlled by an "Elbi" electrovalve which is located underneath the battery tray. A battery of increased capacity is also fitted.

3 The heater system works on the normal principle in conjunction with the engine cooling system and incorporates its own booster (blower) motor.

4 If it is necessary to disconnect any part of the refrigeration system in order to undertake work on other components, then refer to "Precautions" at the beginning of this Chapter.

5 Due to the nature of the refrigerant used in the system, no servicing other than a few basic inspection tasks can be undertaken by the home mechanic.

6 Check the condition and tension of the alternator/compressor drivebelt. Renew the belt if it shows signs of excessive wear.

7 Check the system components for security and condition. Any components which are suspect must be renewed by a specialist. If the system has developed a leak, take care not to allow body contact with the fluid.

8 If the system is not used regularly, then it must be run for a period of about ten minutes once a month to keep it in good condition.

9 No maintenance is required for the electrical wiring part of the system, apart from the occasional check to ensure that the wiring and connections are in good condition and securely located. A line fuse is incorporated into the circuit and in the event of this blowing, the cause should be located and rectified before fitting a new fuse.

10 The fan control module for air conditioning on models manufactured after January 1987 is located on the fan motor casing within the scuttle plenum chamber, instead of being mounted on the steering column support bracket as on earlier models.

16 Air conditioning system - maintenance



1 The air conditioning system layout and main components are as shown (see illustration).

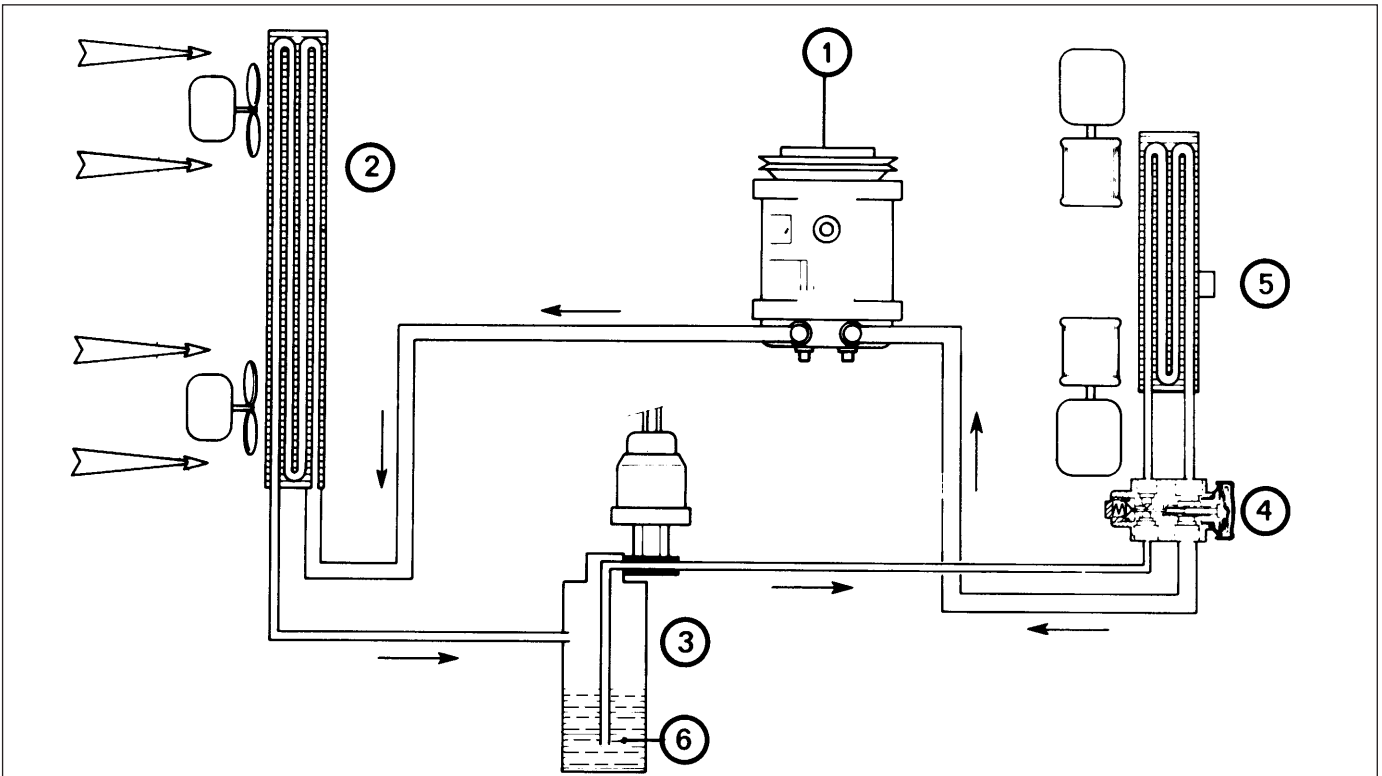

16.1 Air conditioning system layout

1 Compressor
2 Condenser

3 Receiver dryer
4 Pressure release valve

5 Evaporator
6 Freon (refrigeration fluid)