





Chapter 12

Bodywork and fittings

Contents

Bonnet - removal, refitting and adjustment	6	Front wing - removal and refitting	8
Bonnet lock - removal and refitting	7	General information	1
Bumpers - removal and refitting	20	Maintenance - hinges and locks	5
Dashboard - removal and refitting	24	Major body damage - repair	4
Door lock, lock cylinder and handles - removal and refitting	17	Minor body damage - repair	3
Door mirror - removal and refitting	10	Rear door quarter window - removal and refitting	16
Door mirror glass - renewal	11	Rear door window regulator and glass - removal and refitting	15
Door rattles - tracing and rectification	9	Rear seat (Estate) - removal and refitting	26
Door trim panel - removal and refitting	12	Sunroof - manual operation	21
Door window lift channels - modification	13	Sunroof - removal, refitting and adjustments	22
Doors - removal and refitting	18	Tailgate - removal and refitting	19
Floor-mounted centre console (later models) - removal and refitting	25	Vehicle exterior and interior - maintenance and inspection	2
Front door window regulator and glass - removal and refitting	14	Windscreen and tailgate glass - renewal	23

Degrees of difficulty

Easy, suitable for novice with little experience 	Fairly easy, suitable for beginner with some experience 	Fairly difficult, suitable for competent DIY mechanic 	Difficult, suitable for experienced DIY mechanic 	Very difficult, suitable for expert DIY or professional 
--	---	---	--	---

1 General information

The main bodyshell and underframe are of all-steel monocoque construction. Certain components, such as the bonnet, tailgate, rear quarter panels and bumpers, are manufactured in synthetic material. Apart from their rust-free qualities, components manufactured from synthetic material reduce the total weight of the vehicle.

The bumpers are designed to be both light in structure and resistant to low speed impact.

Certain body panels are detachable to reduce the cost of repair and, where necessary, replacement.

The laminated windscreen is bonded in position and provides a considerable increase in the torsional rigidity of the bodyshell.

2 Vehicle exterior and interior - maintenance and inspection

Vehicle exterior

1 The general condition of a vehicle's bodywork is the one thing that significantly affects its value. Maintenance is easy but needs to be regular. Neglect, particularly after minor damage, can lead quickly to further deterioration and costly repair bills. It is

important also to keep watch on those parts of the vehicle not immediately visible, for instance the underbody, inside all the wheel arches and the lower part of the engine compartment.

2 The basic maintenance routine for the bodywork is washing - preferably with a lot of water, from a hose. This will remove all the loose solids which may have stuck to the vehicle. It is important to flush these off in such a way as to prevent grit from scratching the finish. The wheel arches and underbody need washing in the same way to remove any accumulated mud which will retain moisture and tend to encourage rust, particularly in winter when it is essential that any salt (from that put down on the roads) is washed off. Oddly enough, the best time to clean the underbody and wheel arches is in wet weather when the mud is thoroughly wet and soft. In very wet weather the underbody is usually cleaned automatically of large accumulations; this is therefore a good time for inspection.

3 If the vehicle is very dirty, especially underneath or in the engine compartment, it is tempting to use one of the pressure washers or steam cleaners available on garage forecourts. Whilst these are quick and effective, especially for the removal of the accumulation of oily grime which sometimes is allowed to become thick in certain areas, their usage does have some disadvantages. If caked-on dirt is simply blasted off the paintwork, its finish soon becomes scratched

and dull and the pressure can allow water to penetrate door and window seals and the lock mechanisms. If the full force of such a jet is directed at the vehicle's underbody, the wax-based protective coating can easily be damaged and water (with whatever cleaning solvent is used) could be forced into crevices or components that it would not normally reach. Similarly, if such equipment is used to clean the engine compartment, water can be forced into the components of the fuel and electrical systems and the protective coating can be removed that is applied to many small components during manufacture; this may therefore actually promote corrosion (especially inside electrical connectors) and initiate engine problems or other electrical faults. Also, if the jet is pointed directly at any of the oil seals, water can be forced past the seal lips and into the engine or transmission. Great care is required, therefore, if such equipment is used and, in general, regular cleaning by such methods should be avoided.

4 A much better solution in the long term is just to flush away as much loose dirt as possible using a hose alone, even if this leaves the engine compartment looking dirty. If an oil leak has developed, or if any other accumulation of oil or grease is to be removed, there are one or two excellent grease solvents available, which can be brush applied. The dirt can then be simply hosed off. Take care to replace the wax-based protective coat, if this was affected by the solvent.

5 Normal washing of the bodywork is best carried out using cold or warm water with a proprietary car shampoo, tar spots can be removed either by using white spirit, followed by soapy water to remove all traces of spirit. Try to keep water out of the bonnet air inlets and check afterwards that the heater air inlet box drain tube is clear so that any water has drained out of the box.

6 After washing the paintwork, wipe off with a chamois leather to give an unspotted clear finish. A coat of clear protective wax polish, will give added protection against chemical pollutants in the air. If the paintwork sheen has dulled or oxidised, use a cleaner/polisher to restore the brilliance of the shine. This requires a little effort, but such dulling is usually caused because regular washing has been neglected. Care needs to be taken with metallic paintwork, as special non-abrasive cleaner/polisher is required to avoid damage to the finish.

7 Brightwork should be treated in the same way as paintwork.

8 Windscreens and windows can be kept clear of the smeary film which often appears, by the use of proprietary glass cleaner. Never use any form of wax or other body or chromium polish on glass.

Vehicle interior

9 Mats and carpets should be brushed or vacuum cleaned regularly to keep them free of grit. If they are badly stained remove them from the vehicle for scrubbing or sponging and make quite sure they are dry before refitting.

10 Where leather upholstery is fitted it should be cleaned only if necessary, using either a mild soap (such as saddle soap) or a proprietary leather cleaner; do not use strong soaps, detergents or chemical cleaners. If the leather is very stained, seek the advice of a Citroen dealer. Fabric-trimmed seats and interior trim panels can be kept clean by wiping with a damp cloth and a proprietary suitable cleaner. If they do become stained (which can be more apparent on light coloured upholstery) use a little liquid detergent and a soft nail brush to scour the grime out of the grain of the material. Do not forget to keep the headlining clean in the same way as the (fabric) upholstery.

11 When using liquid cleaners of any sort inside the vehicle, do not over-wet the surfaces being cleaned. Excessive damp could get into the seams and padded interior causing stains, offensive odours or even rot. If the inside of the vehicle gets wet accidentally it is worthwhile taking some trouble to dry it out properly, particularly where carpets are involved. *Do not leave oil or electric heaters inside the vehicle for this purpose.*

3 Minor body damage - repair



Repair of minor scratches in bodywork

If the scratch is very superficial and does not penetrate to the metal of the bodywork, repair is very simple. Lightly rub the area of the scratch with a paintwork renovator, or a very fine cutting paste to remove loose paint from the scratch and to clear the surrounding bodywork of wax polish. Rinse the area with clean water.

Apply touch-up paint or a paint film, to the scratch using a fine paint brush. Continue to apply fine layers of paint until the surface of the paint in the scratch is level with the surrounding paintwork. Allow the new paint at least two weeks to harden, then blend it into the surrounding paintwork by rubbing the scratch area with a paintwork renovator, or a very fine cutting paste. Finally apply wax polish.

Where the scratch has penetrated right through to the metal of the bodywork, causing the metal to rust, a different repair technique is required. Remove any loose rust from the bottom of the scratch with a penknife, then apply rust inhibiting paint, to prevent the formation of rust in the future. Using a rubber or nylon applicator fill the scratch with bodystopper paste. If required, this paste can be mixed with cellulose thinners, to provide a very thin paste which is ideal for filling narrow scratches. Before the stopper-paste in the scratch hardens, wrap a piece of smooth cotton rag around the top of a finger. Dip the finger in cellulose thinners, and quickly sweep it across the surface of the stopper-paste in the scratch; this will ensure that the surface of the stopper-paste is slightly hollowed. The scratch can now be painted over as described earlier in this Section.

Repair of dents in bodywork

When deep denting of the vehicle's bodywork has taken place, the first task is to pull the dent out, until the affected bodywork almost attains its original shape. There is little point in trying to restore the original shape completely, as the metal in the damaged area will have stretched on impact and cannot be reshaped fully to its original contour. It is better to bring the level of the dent up to a point which is about 3 mm below the level of the surrounding bodywork. In cases where the dent is very shallow anyway, it is not worth trying to pull it out at all. If the underside of the dent is accessible, it can be hammered out gently from behind, using a mallet with a wooden or plastic head. Whilst doing this, hold a suitable block of wood firmly against the outside of the panel to absorb the impact from the hammer blows and thus prevent a large area of the bodywork from being "belled-out".

Should the dent be in a section of the bodywork which has a double skin or some other factor making it inaccessible from behind, a different technique is called for. Drill several small holes through the metal inside the area - particularly in the deeper section. Then screw long self-tapping screws into the holes just sufficiently for them to gain a good purchase in the metal. Now the dent can be pulled out by pulling on the protruding heads of the screws with a pair of pliers.

The next stage of the repair is the removal of the paint from the damaged area and from an inch or so of the surrounding sound bodywork. This is accomplished most easily by using a wire brush or abrasive pad on a power drill, although it can be done just as effectively by hand using sheets of abrasive paper. To complete the preparation for filling, score the surface of the bare metal with a screwdriver or the tang of a file, or alternatively, drill small holes in the affected area. This will provide a really good key for the filler paste. To complete the repair see the Section on filling and respraying.

Repair of rust holes or gashes in bodywork

Remove all paint from the affected area and from an inch or so of the surrounding sound bodywork, using an abrasive pad or a wire brush on a power drill. If these are not available a few sheets of abrasive paper will do the job most effectively. With the paint removed you will be able to judge the severity of the corrosion and therefore decide whether to renew the whole panel (if this is possible) or to repair the affected area. New body panels are not as expensive as most people think and it is often quicker and more satisfactory to fit a new panel than to attempt to repair large areas of corrosion.

Remove all fittings from the affected area except those which will act as a guide to the original shape of the damaged bodywork (eg headlamp shells etc). Then, using tin snips or a hacksaw blade, remove all loose metal and any other metal badly affected by corrosion. Hammer the edges of the hole inwards in order to create a slight depression for the filler paste.

Wire brush the affected area to remove the powdery rust from the surface of the remaining metal. Paint the affected area with rust inhibiting paint, if the back of the rusted area is accessible treat this also.

Before filling can take place it will be necessary to block the hole in some way. This can be achieved by the use of aluminium or plastic mesh, or aluminium tape.

Aluminium or plastic mesh or glass-fibre matting, is probably the best material to use for a large hole. Cut a piece to the approximate size and shape of the hole to be filled, then position it in the hole so that its edges are below the level of the surrounding bodywork. It can be retained in position by several blobs of filler paste around its periphery.

Aluminium tape should be used for small or very narrow holes. Pull a piece off the roll and trim it to the approximate size and shape required, then pull off the backing paper (if used) and stick the tape over the hole; it can be overlapped if the thickness of one piece is insufficient. Burnish down the edges of the tape with the handle of a screwdriver or similar, to ensure that the tape is securely attached to the metal underneath.

Bodywork repairs - filling and respraying

Before using this Section, see the Sections on dent, deep scratch, rust holes and gash repairs.

Many types of bodyfiller are available, but generally speaking those proprietary kits are best for this type of repair which contain a tin of filler paste and a tube of resin hardener, or a 'No-Mix' which can be used directly from the tube. A wide, flexible plastic or nylon applicator will be found invaluable for imparting a smooth and well contoured finish to the surface of the filler.

Mix up a little filler on a clean piece of card or board - measure the hardener carefully (follow the maker's instructions on the pack) otherwise the filler will set too rapidly or too slowly. Alternatively, a 'No-Mix' can be used straight from the tube without mixing, but daylight is required to cure it. Using the applicator apply the filler paste to the prepared area; draw the applicator across the surface of the filler to achieve the correct contour and to level the surface. As soon as a contour that approximates to the correct one is achieved, stop working the paste - if you carry on too long the paste will become sticky and begin to pick-up on the applicator. Continue to add thin layers of filler paste at twenty minute intervals until the level of the filler is just proud of the surrounding bodywork.

Once the filler has hardened, excess can be removed using a metal plane or file. From then on, progressively finer grades of abrasive paper should be used, starting with a 40 grade production paper and finishing with a 400 grade wet-and-dry paper. Always wrap the abrasive paper around a flat rubber, cork, or wooden block - otherwise the surface of the filler will not be completely flat. During the smoothing of the filler surface the wet-and-dry paper should be periodically rinsed in water. This will ensure that a very smooth finish is imparted to the filler at the final stage.

At this stage, the dent should be surrounded by a ring of bare metal, which in turn should be encircled by the finely feathered edge of the good paintwork. Rinse the repair area with clean water, until all of the dust produced by the rubbing-down operation has gone.

Spray the whole area with a light coat of primer- this will show up any imperfections in the surface of the filler. Repair these imperfections with fresh filler paste or bodystopper and once more smooth the

surface with abrasive paper. If bodystopper is used, it can be mixed with cellulose thinners to form a really thin paste which is ideal for filling small holes. Repeat this spray and repair procedure until you are satisfied that the surface of the filler and the feathered edge of the paintwork are perfect. Clean the repair area with clean water and allow to dry fully.

The repair area is now ready for final spraying. Paint spraying must be carried out in a warm, dry, windless and dust free atmosphere. This condition can be created artificially if you have access to a large indoor working area, but if you are forced to work in the open, you will have to pick your day very carefully. If you are working indoors, dousing the floor in the work area with water will help to settle the dust which would otherwise be in the atmosphere. If the repair area is confined to one body panel, mask off the surrounding panels; this will help to minimise the effects of a slight mis-match in paint colours. Bodywork fittings (eg chrome strips, door handles etc) will also need to be masked off. Use genuine masking tape and several thicknesses of newspaper for the masking operations.

Before commencing to spray, agitate the aerosol can thoroughly, then spray a test area (an old tin, or similar) until the technique is mastered. Cover the repair area with a thick coat of primer; the thickness should be built up using several thin layers of paint rather than one thick one. Using 400 grade wet-and-dry paper, rub down the surface of the primer until it is really smooth. While doing this, the work area should be thoroughly doused with water and the wet-and-dry paper periodically rinsed in water. Allow to dry before spraying on more paint.

Spray on the top coat, again building up the thickness by using several thin layers of paint. Start spraying in the centre of the repair area and then, with a side-to-side motion, work outwards until the whole repair area and about 50 mm of the surrounding original paintwork is covered. Remove all masking material 10 to 15 minutes after spraying on the final coat of paint.

Allow the new paint at least two weeks to harden, then, using a paintwork renovator, or a very fine cutting paste, blend the edges of the paint into the existing paintwork. Finally, apply wax polish.

Plastic components

With the use of more and more plastic body components by the vehicle manufacturers (eg bumpers, spoilers and in some cases major body panels), rectification of more serious damage to such items has become a matter of either entrusting repair work to a specialist in this field, or renewing complete components. Repair of such damage by the DIY owner is not really feasible owing to the cost of the equipment and materials required for effecting such repairs. The basic technique involves making a groove along the line of the crack in the plastic using a rotary burr in a

power drill. The damaged part is then welded back together by using a hot air gun to heat up and fuse a plastic filler rod into the groove. Any excess plastic is then removed and the area rubbed down to a smooth finish. It is important that a filler rod of the correct plastic is used, as body components can be made of a variety of different types (eg polycarbonate, ABS, polypropylene).

Damage of a less serious nature (abrasions, minor cracks etc) can be repaired by the DIY owner using a two-part epoxy filler repair material, or a 'No-Mix' which can be used directly from the tube. Once mixed in equal proportions (or applied direct from the tube in the case of the 'No-Mix'), this is used in similar fashion to the bodywork filler used on metal panels. The filler is usually cured in twenty to thirty minutes, ready for sanding and painting.

If the owner is renewing a complete component himself, or if he has repaired it with epoxy filler, he will be left with the problem of finding a suitable paint for finishing which is compatible with the type of plastic used. At one time the use of a universal paint was not possible owing to the complex range of plastics encountered in body component applications. Standard paints, generally speaking, will not bond satisfactorily to plastic or rubber, but professional spraymatch paints to match any plastic or rubber finish can be obtained from dealers. However, it is now possible to obtain a plastic body parts finishing kit which consists of a pre-primer treatment, a primer and coloured top coat. Full instructions are normally supplied with a kit, but basically the method of use is to first apply the pre-primer to the component concerned and allow it to dry for up to 30 minutes. Then the primer is applied and left to dry for about an hour before finally applying the special coloured top coat. The result is a correctly-coloured component where the paint will flex with the plastic or rubber, a property that standard paint does not normally possess.

4 Major body damage - repair



Where serious damage has occurred, or large areas need renewal due to neglect, it means that complete new panels will need welding in. This is best left to professionals. If the damage is due to impact, it will also be necessary to check completely the alignment of the bodyshell. This can only be carried out accurately by a Citroen dealer using special jigs. If the body is left misaligned, it is primarily dangerous as the vehicle will not handle properly and secondly, uneven stresses will be imposed on the steering, suspension and possibly transmission, causing abnormal wear or complete failure, particularly to items such as the tyres.

5 Maintenance - hinges and locks



- 1 Periodically, oil the hinges of the bonnet, doors and tailgate with a little light oil. A good time is after the car has been washed.
- 2 Oil the bonnet release catch mechanism and striker pin.
- 3 Do not over lubricate door latches and strikers. A little oil on the lock spindle is sufficient.

6 Bonnet - removal, refitting and adjustment



Removal

- 1 Support the bonnet in its open position and place some cardboard or rags beneath the corners by the hinges.
- 2 The bonnet is not adjustable at the hinges for position so there is no need to mark their relative positions.
- 3 With the help of an assistant, unscrew the four retaining nuts, noting that an earth strap is located beneath the rear nuts (see illustration). Lift the bonnet from the vehicle.

Refitting

- 4 Refitting the bonnet is a reversal of removal. When fitted, close the bonnet and check it for correct alignment. An even clearance should exist around the bonnet at the wings, the bulkhead grille and the headlights, and the front bumper at the leading edge.
- 5 When fully closed, there should be a 10 mm clearance between the bonnet leading edge and the headlamp unit each side, the bonnet top face being flush to the top edge of the wing panels.
- 6 Check that when fully closed, the bonnet is fully locked, then release the lock and check that the safety catch operates correctly.

Adjustment

- 7 If necessary, the bonnet lock and safety catch can be adjusted by loosening the retaining bolts or nuts as applicable, repositioning the lock unit or safety catch and



8.5 Remove the retaining bolts and washers (arrowed) from the front wing leading edge



6.3 Bonnet hinge retaining nuts. Note earth strap under lower nut and washer

retightening the bolts/nuts. Recheck the operation of the lock and safety catch on completion.

7 Bonnet lock - removal and refitting



Removal

- 1 Open the bonnet and support it. If a malfunction of the bonnet lock or cable does not allow the bonnet to open by normal means, it can be released by inserting a suitable length of wire rod hooked over at its end between the headlamp unit and the underside of the bonnet. Hook the end of the rod onto the release lever and pull it towards the left to release the lock.
- 2 Loosen the cable clamp screw and disconnect the cable from the lock operating lever (see illustration).
- 3 Mark the location of the lock with a pencil, then loosen the two retaining bolts and withdraw the lock.

Refitting

- 4 Refit the lock by reversing the removal procedure. Align it with the pencil marks made during removal before tightening the bolts. Adjust the release cable to remove almost all slackness from it. This can be judged by allowing a fraction of free movement at the release knob end.
- 5 Closure of the bonnet should now be checked and, if necessary, adjusted.



8.6 Remove single retaining bolt and washer (arrowed) from the front wing

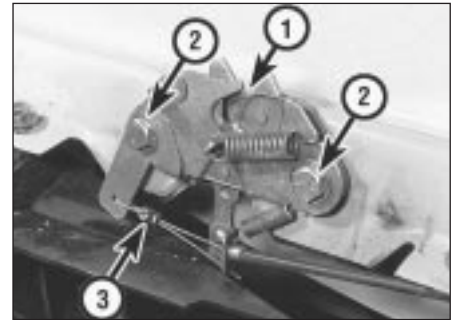

7.2 Bonnet lock (1), retaining bolts (2) and cable clamp (3)

8 Front wing - removal and refitting



Removal

- 1 Disconnect the battery earth lead.
- 2 Remove the headlight unit and front indicator unit from the side concerned.
- 3 Where possible, make pencilled alignment marks of the wing position against corresponding body panels to assist with correct realignment when refitting.
- 4 Undo and remove the bolts and nuts along the top edge of the wing (five in all).
- 5 Disconnect the wing at the front leading edge by undoing the two retaining bolts (see illustration).
- 6 Undo and remove the single retaining bolt and washer (see illustration).
- 7 Open the front door fully then undo the two rear edge retaining bolts (see illustration).
- 8 The wing panel can now be lifted away after prising it free from the mastic at the flange joints.

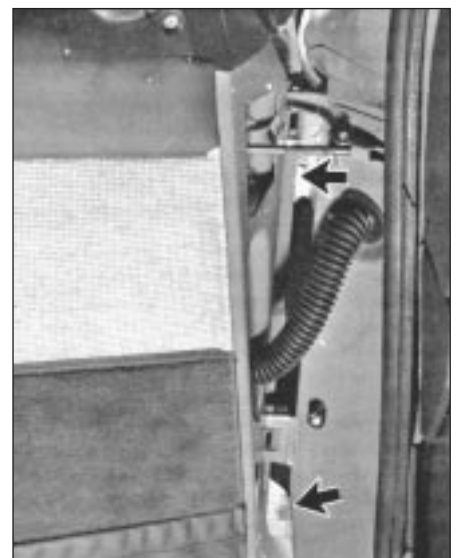

8.7 Front wing rear edge retaining bolt locations (arrowed)



8.9 Captive nut locations (arrowed) for attachment of front wing



10.1 Door mirror adjuster knob and gaiter



10.3 Countersunk screw retaining the inner plate (arrowed)

Refitting

9 Before refitting the wing panel, clean away all the old mastic sealant and apply a new bead of sealant. Check the three captive nuts are in the positions shown (see illustration).

10 When refitting the wing, do not fully tighten the retaining bolts until they are all in position and the wing is correctly aligned with the adjacent panels.

11 When the headlight and indicator units are refitted, reconnect the battery and check for satisfactory operation of the lights.

12 Check headlamp alignment.

10 Door mirror - removal and refitting

Removal

1 Prise back the rubber gaiter from the trim panel and pull free the adjuster knob and gaiter (see illustration).

2 Undo the inset screw and remove the trim plate.

3 Undo the countersunk screw and remove the inner retaining plate (see illustration).

4 Support the mirror unit and undo the two retaining nuts using a suitable socket or box spanner (see illustration). Remove the mirror unit.

Refitting

5 Refit in the reverse order of removal.



10.4 Door mirror retaining nuts (arrowed)

9 Door rattles - tracing and rectification

1 Check the door is not loose at the hinges and the latch is holding it firmly in position. Check also that the door aligns with the body aperture, if not, then it must be adjusted.

2 If the latch is holding the door in the correct position but the latch still rattles, the lock mechanism is worn out and requires renewal.

3 Other rattles from the door could be caused by wear in the window operating mechanism or electric motors, interior lock mechanism, or loose glass channels.

11 Door mirror glass - renewal

1 This can be achieved with the mirror unit in position on the door. To protect the door

paintwork, wind down the door window and cover the panel with a suitable cloth.

2 One of two types of mirror will be fitted, being either of Britax or Hohe manufacture (see illustration). The glass replacement for each differs as given below.

Britax mirror

3 With this type, the glass is bonded in position in each corner at the points indicated (see illustration). Break the glass (using care) and remove the remaining fragments.

4 Clean the bonding adhesive from the four points indicated in the mirror unit.

5 Carefully peel off the backing paper from

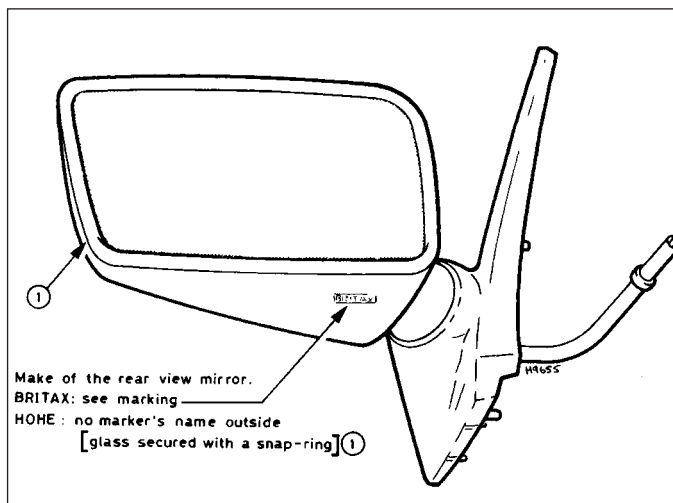

11.2 Door mirror type identification

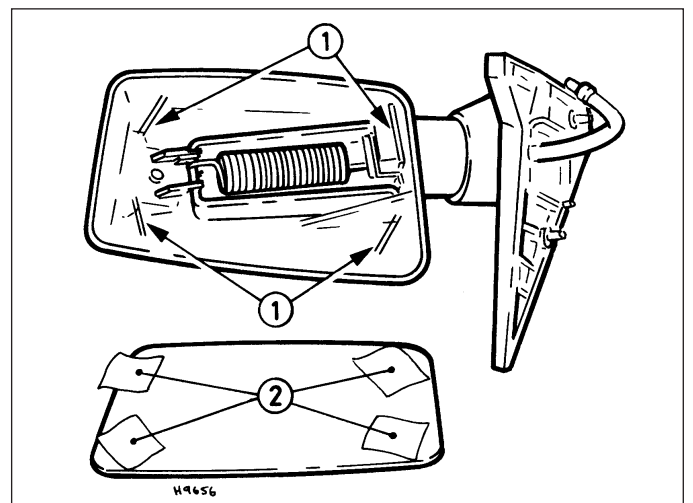

11.3 Britax type mirror showing glass bonding points (1 and 2)

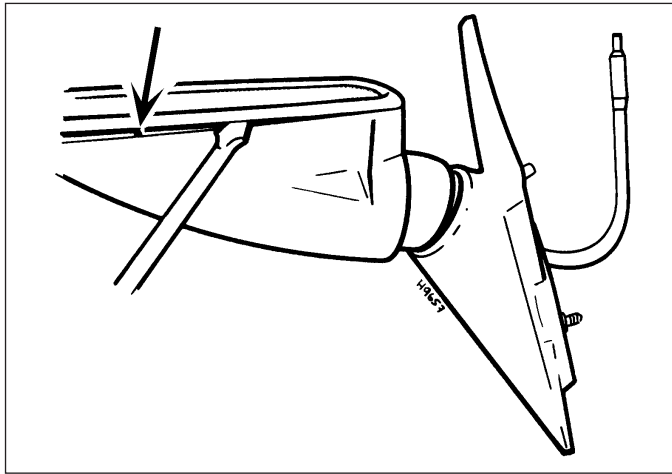

11.6 Prise free the retaining ring (arrowed) to remove the glass - Hohe type mirror

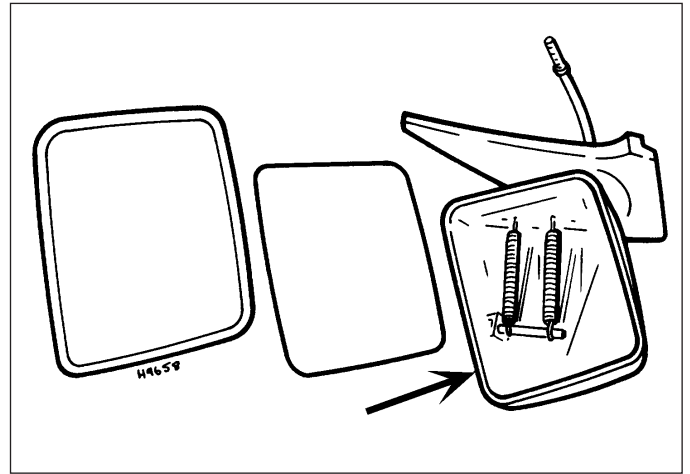

11.8 Apply sealant around perimeter (arrowed) - Hohe type mirror

the adhesive squares on the rear of the new glass then carefully locate and press the glass into position in the mirror unit.

Hohe type mirror

6 Carefully prise free the retaining ring from the perimeter of the glass using a flat-bladed screwdriver and extract the glass (see illustration).

7 A new retaining ring will be supplied with the mirror glass. It will be necessary to cut the ring securing lugs down by half before the mirror and ring can be fitted.

8 Clean the perimeter area of the mirror unit to which the retaining ring is to fit. Apply a thin bead of sealant (epoxy glue Ref ZC 9 865105 U, polyurethane sealant Ref ZC 9 867 433 U or equivalent) around the perimeter area of the mirror unit to which the sealing ring will fit (see illustration).

9 Carefully locate the glass and the retaining ring into position. Secure them in this position using adhesive tape for the period specified by the glue/sealant manufacture to allow full adhesion of the ring and glass to the mirror, then remove the tape.

5 Using a wide-bladed tool inserted between the door inner trim panel and the door, release the panel securing clips.

6 Remove the trim panel and take off the winder handle coil spring.

7 For access to the inner door components, carefully peel back the plastic insulation sheet.

8 Refitting is a reversal of the removal procedure.

Electrically operated windows

9 The switches for electrically operated windows are mounted in the door panels.

When removing the door trim panels, it is necessary to prise free the switches from the panel using a thin-bladed screwdriver, then disconnect the wiring from the switches (see illustrations).

10 The window regulator switches are mounted in a secondary panel attached to the main door panel. If required, the panels can be separated by undoing the retaining screws from the rear face (see illustration).

11 If door-mounted radio speakers are fitted, the wires for these will also have to be disconnected to allow the door panels to be removed.

12 Door trim panel - removal and refitting



Manually operated windows

1 Insert a piece of wire with a small hook at its end, between the window winder handle and the boss on the door inner panel. Engage the hook with the handle securing spring clip and extract the clip. Remove the handle (see illustration).

2 Unscrew and remove the door lock knob.

3 Undo the three retaining screws and remove the door pull/armrest. Unclip and remove the door pull/armrest bezel.

4 Remove the door mirror adjuster knob, gaiter and trim plate.



12.1 Removing the window winder handle (manual type)

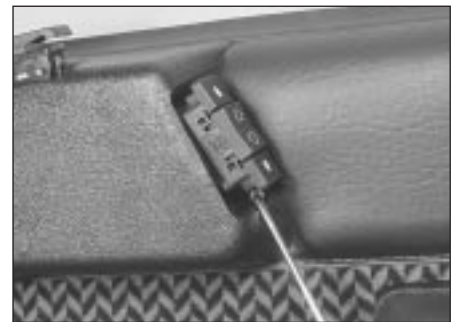

12.9a Window regulator switch prised from door



12.9b Window regulator switches withdrawn to expose wiring



12.10 Extracting a screw from the window regulator mounting panel



14.2 Door glass runner channel retaining nuts (arrowed)

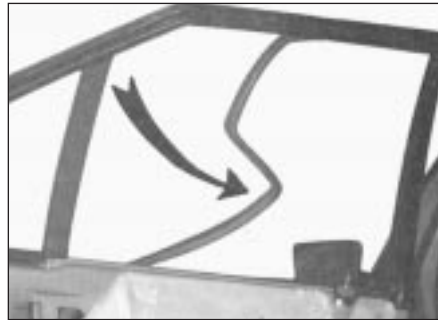

16.2 Fold back the weatherstrip from the rear door window/quarter window

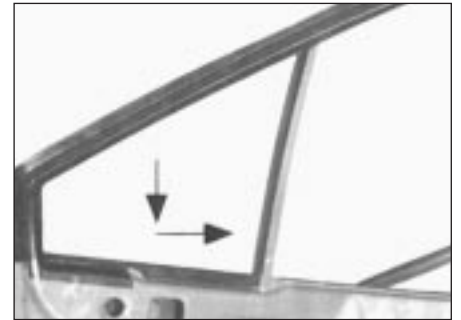

16.4 Direction of rear door quarter window removal

13 Door window lift channels - modification



1 On early models, the window lift channels are glued to the side of the glass. Later models have slotted channels with rubber inserts.

2 If problems are experienced with early-type channels coming unstuck, purchase a modification kit from a Citroën dealer and fit the later-type channels.

3 Mark the position of the old lift channels before removal (saw or prise them off), and fit the new ones in the same position. Measuring horizontally from the front bottom corner of the glass, the front edge of the lift channel should be 207 mm from the corner on the front windows, 124 mm from the corner on the rear windows.

14 Front door window regulator and glass - removal and refitting



Removal

- 1 Remove the door inner trim panel.
- 2 Remove the electrically operated window regulator unit. Unbolt the roller runner channel (see illustration).
- 3 To remove the manually operated window regulator unit, unscrew the regulator retaining nuts and push the regulator into the door cavity.
- 4 Support the glass and release the rollers from the runner channel.
- 5 Withdraw the regulator from the door.
- 6 To remove the door glass, carefully detach and remove the waistline seal by prising it free from the retaining clips. Renew this seal if it is excessively worn or damaged.
- 7 Tilt the glass upwards at the rear and carefully withdraw it from the door.

Refitting

8 Refitting is a reversal of the removal procedure. Lubricate the regulator guide channels with light grease.

15 Rear door window regulator and glass - removal and refitting



The procedures for removal and refitting are the same as those given for the front doors. However, before removing the door glass it is also necessary to remove the channel weatherstrip from the window aperture at its upper, lower and rear edges.

When refitting the glass, lower it into position and locate it into its guide channels in the lower door section then refit the weatherstrip.

16 Rear door quarter window - removal and refitting



Removal

- 1 Lower the door window then remove the inner door trim panel. Peel back the insulation sheet from the rear quarter section of the door.
- 2 Detach the main window weatherstrip from the rear separator and partially along its upper and lower aperture fixings (see illustration).
- 3 Detach and remove the rear separator and the lower inner strip from the bottom edge of the quarter window.
- 4 Press the quarter window downwards and



17.2 Door lock retaining screws and nylon grommet

forwards and carefully lever it away inwards at the top corner (see illustration). Remove the quarter window, complete with its weatherstrip.

5 If re-using the weatherstrip, clean it of mastic sealant.

Refitting

6 Refitting is a reversal of the removal procedure. Apply a thin bead of mastic sealant around the outer periphery of the quarter window weatherstrip prior to fitting it into position.

17 Door lock, lock cylinder and handles - removal and refitting



1 Fully raise the door window and remove the inner trim from the door.

Door lock

- 2 Prise free the nylon grommet from the rear edge of the door (see illustration).
- 3 Disconnect the control rods from the lock unit, taking care not to damage the nylon fasteners (see illustration). As they are disconnected, note their respective connecting points.
- 4 Undo the three retaining screws and withdraw the lock unit.
- 5 Refitting is a reversal of the removal procedure.

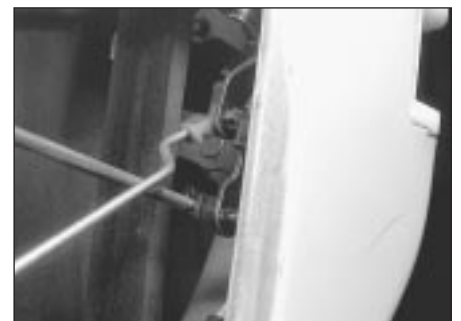

17.3 Door lock control rods and nylon fasteners

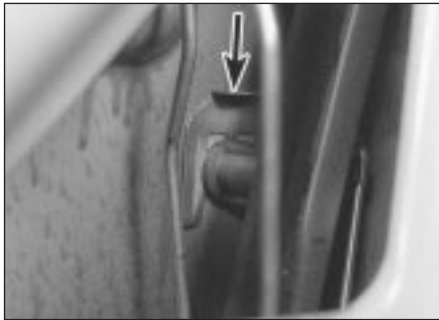

17.6 Door lock cylinder and retaining clip (arrowed)



17.8 Door outer handle retaining nut (arrowed)



17.10 Door inner handle and retaining bolts (arrowed)



18.7a Door adjustment tool

Lock cylinder

6 Detach the connecting rod, then prise free the retaining clip (see illustration). Withdraw the cylinder.

7 Refit in the reverse order of removal.

Outer handle

8 Detach the connecting rod from the lock unit then undo the two retaining nuts and remove the handle (see illustration).

9 Refit in the reverse order of removal.

Inner handle

10 Detach the connecting rod to the lock unit, undo the two retaining bolts and remove the handle (see illustration).

11 Refit in the reverse order of removal.

during this operation. Take care not to distort the hinges when removing the pins. Lift the door from the vehicle.

Refitting

5 Refitting is a reversal of removal. On completion, check the door for alignment, as follows.

6 Close the door gently. If it will not close or if, when it is closed, the door exterior panel is not flush or in correct alignment with the adjacent body panels adjust the door in the following way.

7 Open the door and using a suitably cranked bar, prise the relevant hinge (see illustrations). The hinges are welded to the door and the body pillar, and bending the hinges is the only means of adjustment. Do not overdo this, or it will be virtually impossible to rectify matters and the hinges will have to be renewed using a welding torch.

8 Once the adjustment is correct, release the door striker and adjust its position to engage smoothly in the lock tongue.



18.7b Adjusting door position by moving a hinge

solenoid unit (as applicable). Also disconnect the earth wires whilst noting their connections.

4 Disconnect the hose from the rear washer nozzle.

5 Withdraw the wires and the rear washer hose from the tailgate.

6 Get an assistant to support the tailgate or securely prop it, then disconnect the gas-filled struts by extracting the retaining clip at their top or bottom ends (see illustrations).

7 Carefully prise free the hinge retaining clip each side and remove the tailgate (see illustration). If renewing the hinge pin and clips, note that there are three types used.

8 Refitting is a reversal of removal. On

18 Doors - removal and refitting



Removal

1 Remove the door trim.

2 Disconnect the wiring from the lock solenoid and the window regulator units, as applicable, and pull the wiring harness from the leading edge of the door.

3 Open the door fully and support it with blocks or a suitable jack. Use a newspaper or rag to protect the paintwork from being scratched by the support.

4 Use a suitable diameter punch and drive out the roll pins from the door check strap and hinges. Get an assistant to support the door

19 Tailgate - removal and refitting



Hatchback

1 Disconnect the battery earth lead.

2 Prise free the retaining clips and remove the rear trim panels from the tailgate.

3 Detach the wiring connections to the rear number plate lamps, the rear window demister, the rear wiper motor and the lock



19.6a Support strut and retaining clip to tailgate



19.6b Tailgate support strut and retaining clip to body



19.7 Tailgate hinge retaining clip



19.11 Prising out tailgate strut balljoint clip

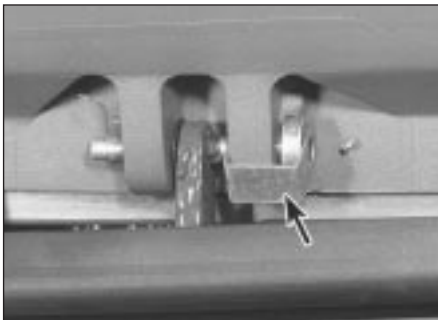

19.12 Tailgate hinge pin retaining clip (arrowed)

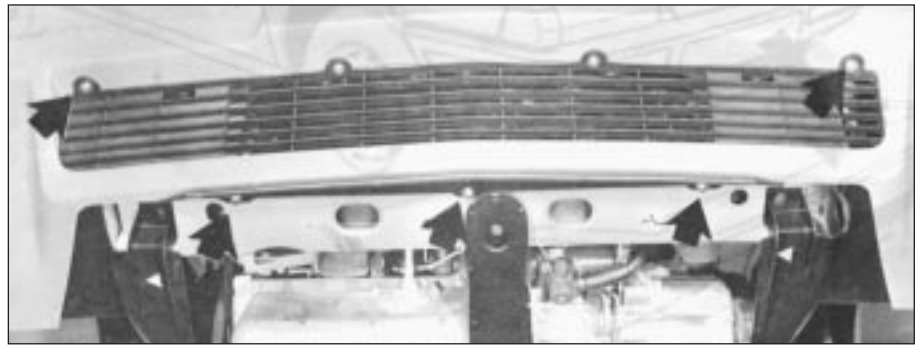

20.3 Front bumper retaining bolts (arrowed)

completion, check the operation of the tailgate functions prior to refitting the trim panels. Check the tailgate for alignment and satisfactory locking action.

Estate

- 9 Disconnect the battery.
- 10 Open the tailgate fully. Disconnect the wiring (heated glass element, rear wiper and central locking) and the washer hose. Extensive dismantling of the interior side trim panels and window surrounds will be required in order to gain access to the wiring plugs.
- 11 With an assistant supporting the tailgate, prise out the spring clips from the strut balljoints (see illustration) and pull the struts off their ball studs.
- 12 Prise off the retaining clips and tap the hinge pins out. Lift the tailgate from the vehicle (see illustration).
- 13 Refitting is a reversal of removal.

20 Bumpers - removal and refitting



Front

- 1 Raise and support the bonnet. Detach and remove the flexible panel between the headlamp units.
- 2 Unscrew and remove the three bumper retaining bolts from the top face of the bumper (between the headlamp units).
- 3 From underneath, unscrew and remove the five bolts (see illustration).
- 4 With the aid of an assistant, simultaneously pull the bumper outwards at each corner and withdraw the bumper forwards from the vehicle.
- 5 Refit in the reverse order of removal, ensuring that the captive nuts are in position before fitting the bumper into position.

Rear Hatchback

- 6 Remove the rear combination light units.
- 7 Unscrew and remove the three retaining bolts from the top face of the bumper.
- 8 From underneath, unscrew and remove the three retaining bolts at the rear then remove the bumper in the same manner as that described for the front bumper.
- 9 Refit in the reverse order of removal, ensuring that the captive nuts are in position before fitting the bumper into position.

Estate

- 10 The rear bumper comprises a centre section secured to the tailgate by screws, and two end sections held by screws and clips.
- 11 Remove the screws and withdraw the bumper. The end sections slide rearwards off the clips (see illustrations).
- 12 Refitting is a reversal of removal.



20.11a Unscrewing a rear bumper lower screw



20.11b Unscrewing a rear bumper upper screw



20.11c Rear bumper end clip viewed from underneath vehicle

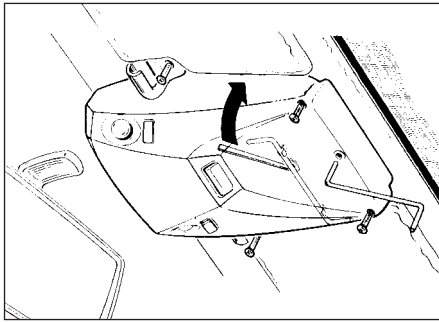

21.3 Crank handle for sunroof manual adjustment is located within roof console

21 Sunroof - manual operation



1 In the event of a malfunction of the sunroof electric motor, the roof panel can be closed manually.

2 Check that the sunroof operating switch is in the off position, then undo the four screws retaining the roof console in position and lower the console from the roof.

3 A manual crank handle is contained within the roof console, secured by spring clips. Remove the crank handle and engage it into the manual crank hole in the winder mechanism. Turn the handle to shut the roof panel (see illustration).

22 Sunroof - removal, refitting and adjustments



Removal

1 With the roof panel in the closed position, raise it at its rear edge so that it is in the airflow to the passenger compartment position.

2 If required, undo the three retaining screws and remove them from the mobile frame at the front edge.

3 Unscrew and remove the three retaining screws each side and then lift out the sunroof from its tilt frame.

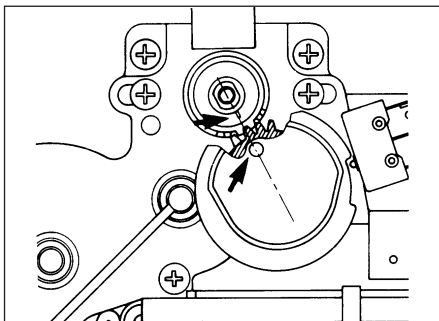

22.6 Sunroof motor reduction gears in alignment

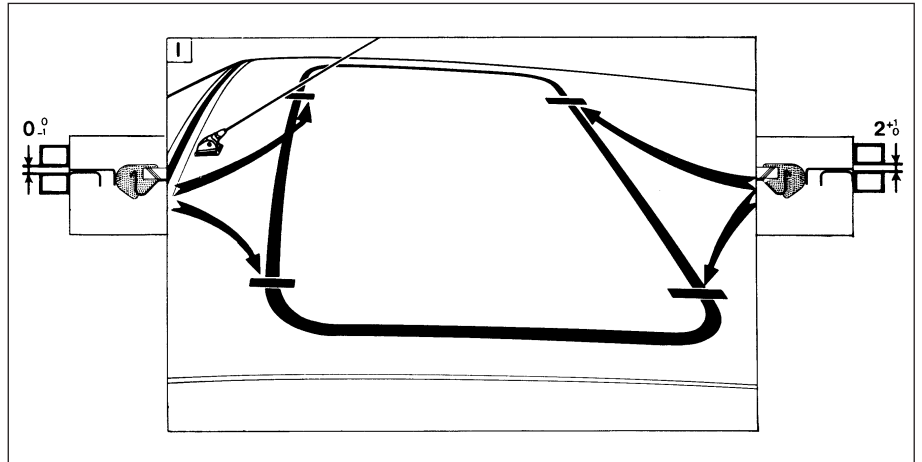

22.5 Sunroof alignment check points
Clearances in mm

Refitting

4 Refitting is a reversal of the removal procedure. Check that the tilt pivots are engaged each side before refitting the panel.

5 On completion, check the roof panel for correct alignment when in the closed position (see illustration). The panel should be parallel at its forward and rear edges with the vehicle roof within the tolerances indicated.

6 If alignment is not within the limits specified, lower the roof console and check to see if the alignment marks of the motor reduction gears correspond (see illustration). If they do not, then proceed as follows.

Adjustment

7 Insert the emergency manual crank handle, check that the roof panel is fully closed and move the reducer lever clockwise to the angle shown (see illustration) to disengage the reducer.

8 Undo the two retaining screws and uncouple the motor/reducer unit from the operating cables. Check that roof alignment is now correct.

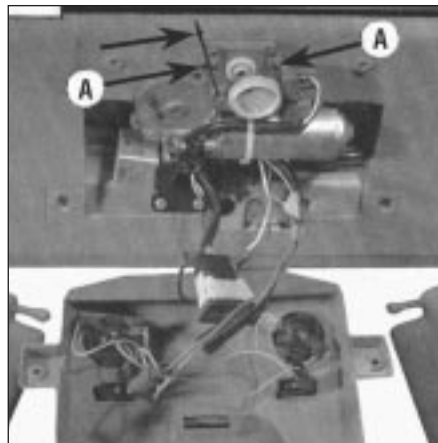

22.7 Reducer lever set to disengage reducer (arrowed)
A - Retaining screws

9 To adjust the reducer gears, turn the small cam anti-clockwise to the point where the large gear cam stops meshing with it. It is particularly important that the microswitch is located on the rear of the large cam and not in the cam recess (see illustration). Holding the cam firmly in this position, turn the small cam clockwise to the point where the gears start to mesh then move the reducer lever back to its original position. Turn the cams to align the gear alignment marks.

10 Reconnect the operating cables, relocate the motor reducer unit and refit the two retaining screws.

11 Refit the roof console and check that the sunroof operates in a satisfactory manner. Recheck the sunroof alignment and free play when closed. If excessive distortion (more than 3 mm) still exists, proceed as follows.

12 Remove the roof console and turn the reducer lever clockwise to the angle shown.

13 Engage the emergency manual handle with the small reduction cam and wind it to fully open the roof panel.

14 Undo the two retaining screws and uncouple the motor reducer unit from the operating cables, then carefully push the two cables with cams towards the front by pressing the frame pivots each side (see illustration).

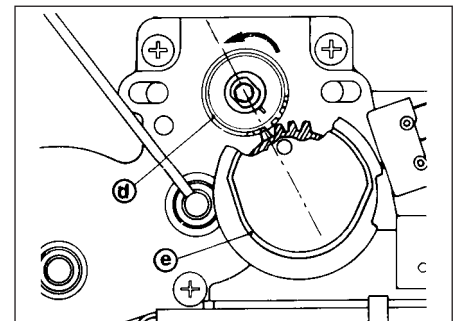

22.9 Reducer gear adjustment
Turn small cam (d) anti-clockwise to disengage from large cam (e)

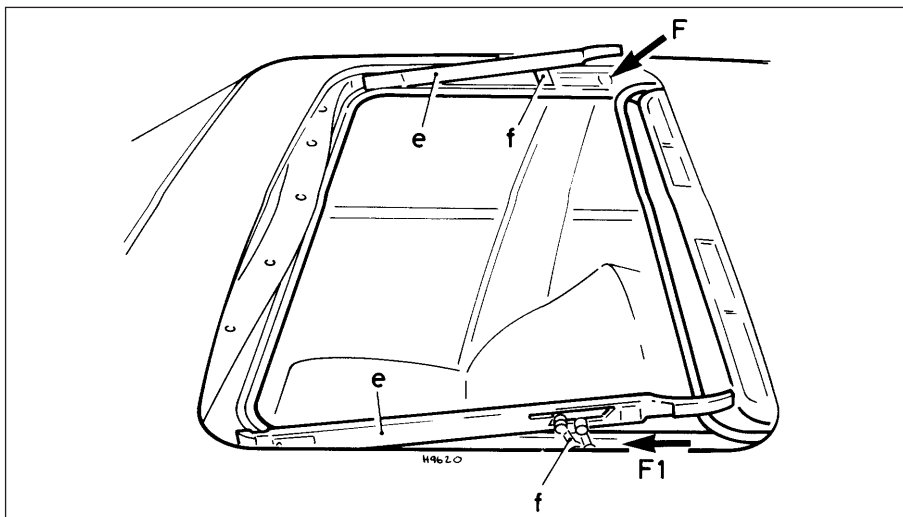

22.14 Sunroof side channels (e) and cams (f) shown with glass panel removed for clarity
F and F1 are the frame pivots

15 Refit the motor/reducer and engage the cables.

16 Manually close the sunroof and recheck the roof alignment and free play. If necessary, adjust the reducer gear alignment marks as described previously. Reset the reducer lever to its original setting before refitting the roof console.

23 Windscreen and tailgate glass - renewal



If you are unfortunate enough to have a windscreen or tailgate glass breakage, the removal and fitting of a replacement is one of the few jobs that the average owner is advised to leave to a Citroën dealer or body repair specialist. Body specialists are familiar with the procedures involved and have the necessary equipment for renewal. Specific sealant products are also required and unless these are used the rigidity of the assembly and its sealing capabilities will be impaired.



24.10 Undo the two retaining bolts (arrowed)

24 Dashboard - removal and refitting



Early models

- 1 Disconnect the battery earth lead.
- 2 Prise free the glovebox light lens, withdraw the switch/light unit and detach the wiring connections from it.
- 3 Remove the retaining screws and remove the steering column lower shroud and lower trim panel on the driver's side, and the lower trim panel on the passenger side.
- 4 Remove the instrument panel.
- 5 Disconnect the wiring connector at the point indicated (see illustration).
- 6 Remove the screw from the side of the corner vent trim (open the door for access).
- 7 Detach the fuse/relay box unit and disconnect from it the wiring loom connections from the steering column switches.
- 8 Undo the four retaining bolts and lower the steering column from the upper mounting bracket.
- 9 Remove the upper facia-mounted speaker units from each side.

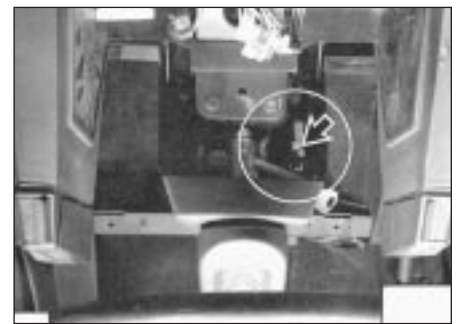

24.5 Detach the wiring connector (arrowed)

10 Working from the engine compartment, undo the dashboard retaining bolt from each side of the bulkhead (see illustration).

11 The dashboard can now be carefully withdrawn. As it is removed, check that all wiring is disconnected and withdraw the left-hand column switch wiring harness (to the fusebox) through with it whilst noting its route location on the underside of the dashboard.

12 Refitting is a reversal of the removal procedure. Ensure all wiring connections are securely and correctly made and that the loom routing is made as noted during removal.

13 On completion, check the operations of the various switch and instrument functions.

Later models

14 While the dashboard layout differs on later models, the main differences concerning its removal are the associated components attached to it, such as the revised heater controls and the later-type steering column and facia switches. Removal procedures for the dashboard are otherwise similar to those described for early models.

25 Floor-mounted centre console (later models) - removal and refitting



The floor-mounted centre console on later models is secured by two bolts on top and a screw each side at the front. The bolts are recessed in the upper face of the panel and are accessible after removal of the plastic covers. These can be prised free (see illustration).



25.1 Removing plastic cover for access to centre console retaining bolt

12•12 Bodywork and fittings

When removing the console, it may be necessary to detach the wiring connectors from any switches mounted in the console. Some models also have radio headphone jack points mounted in the rear of the console and these will also have to be detached.

26 Rear seat (Estate) - removal and refitting



- 1 Pivot the seat cushion forwards.
- 2 Pull the seat back downwards.
- 3 Prise up the hinge cover flap to expose the seat hinge bolts.
- 4 Unscrew the hinge bolts and remove the seat back (**see illustration**).
- 5 The seat cushion can be removed after disconnecting the hinges in a similar way.
- 6 Refitting is a reversal of removal.



26.4 Unscrewing rear seat back hinge bolt