



CLIMATISATION

EDITION 05/2003 - Cat 14.761

CITROËN

COMPRESSEUR

COMPRESSOR
COMPRESOR
COMPRESSOR
KOMPRESSOR
COMPRESSORE
KOMPRESSOR

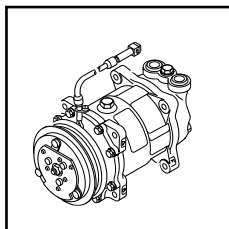
**DETENDEUR REFRI**

AIR CON REGULATOR
VALVULA EXPANSION
DISTENSOR REFRI
EXPANSIONSVENTIL
TENDITORE
DRUKKONTAKT AIRCO

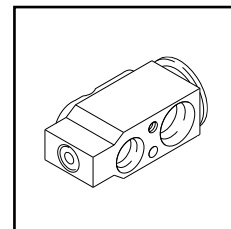
**DESHYDRATEUR REFRI**

AIR CON DEHYDRATER
DESHIDRATADOR
DESIDRATADOR REFRI
TROCKNERBEHAELTER
DISIDRATATORE
AIRCODROGER

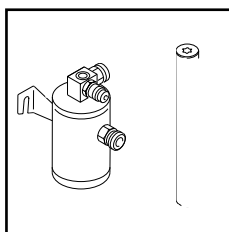
**AEROTHERME**

HEATER MATRIX
RADIADOR CALEFACCION
RADIADOR TERMICO
VERDAMPFER
EVAPORATORE
KACHELRADIATEUR

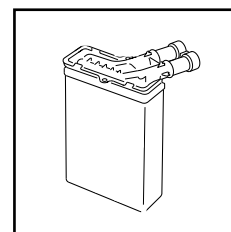
**MANOCONTACT**

SWITCH
MANOCONTACTO
MANOCONTACTO
DRUCKSCHALTER
MONOCONTATTO
MANOKONTAKT

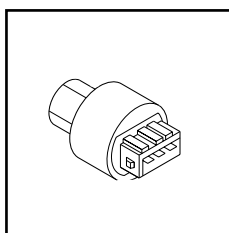
**FILTRE D'HABITACLE**

PARTICLE FILTER
FILTRO DE HABITACULO
FILTRO DE HABITÁCULO
INNENRAUMFILTER
FILTRO ABITACOLO
INTERIEURFILTER

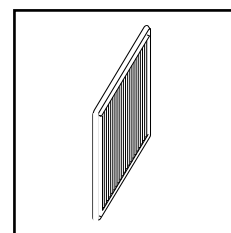
**CONDENSEUR**

CONDENSER
CONDENSADOR
CONDENSADOR
KONDENSER
CONDENSATORE
CONDENSOR

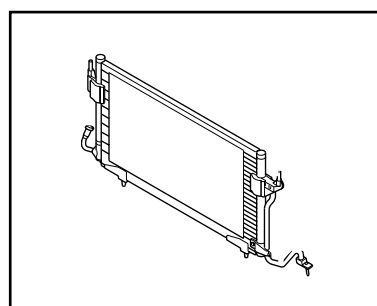

ENTRETIEN CLIMATISEUR

AIR CON MAINTENANCE - MANTENIMIENTO CLIMATIZADOR

LIMPEZA CLIMATIZADOR - WARTUNG KLIMAANLAGE

MANUTENZIONE CLIMATIZZATORE - ONDERHOUD AIRCONDITIONING

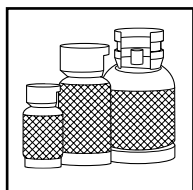

RECHARGE

RECHARGE
RECARGA
RECARGA
KUEHLMITTEL
RICARICA
HERVULLING
ZC 9 866 107 U NFP
ZC 9 871 224 U
9452 64
Frio pack

R12 1 kg
R134A 5 kg
R134A 12Kg

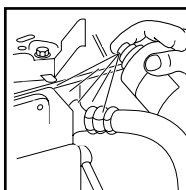

DETECTEUR DE FUITE DE GAZ

GAS LEAK DETECTOR
DETECTOR FUGAS DE GAS
DETECTOR DE FUGA DE GAS
LECKINDIKATOR
RILEVATORE FUGHE DI GAS
GASLEKDETEKTOR
9984.A8 DF9 400 ml
RP 9733 07

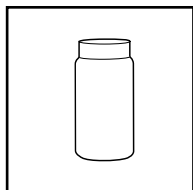

STERILISANT ANTI-ODEUR

DEODERISER
ESTERILIZANTE ANTI-OLOR
ESTIRILIZADOR DO AR
GERUCHSNEUTRALISATOR
STERILIZZANTE ANTIODORE
STERILISERENDE LUCHTVERFRISSE

9986 53 100 ml (UC12)
Airco Clean Ultrasonic



NETTOYANT CLIMATISATION

AIRCO CLEANER
LIMPIADOR CLIMATIZACION
PRODUTO LIMPEZA AR CONDICIONADO
REINIGER FUER KLIMAANLAGE
PULITORE CLIMATIZZAZIONE
AIRCOREINIGER

9986 52 200 ml (UC6)

HUILE DE COMPRESSEUR

COMPRESSOR OIL
ACEITE DE COMPRESOR
OLEO DE COMPRESSOR
KOMPRESSOROEL
OLIO COMPRESSORE
KOMPRESSOR OLIE

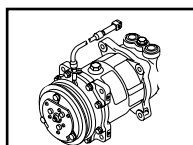

SANDEN
SD7 V16

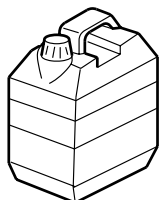

SP 10
9735 C4
(250 ml)

9735 C5
(40 ml)

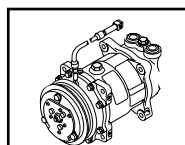

SANDEN
SD7 H15

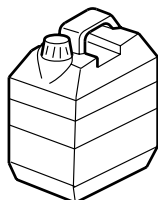

SP 20
9735 C6
(250 ml)

9735 C8
(40 ml)

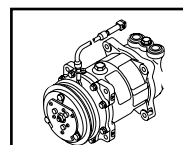

HARRISON
DELPHI V5

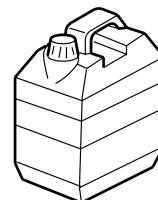

PAG 488
9979 40
(250 ml)

9979 41
(40 ml)

CITROËN AX

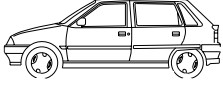
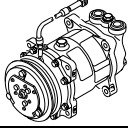
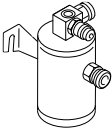
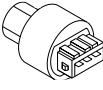
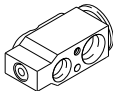
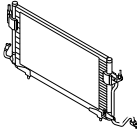
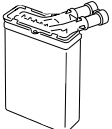
							
	Neuf	E.S.					
Ess → 05/91	96 045 096 NFP	-	6455 R1	96 045 108 NFP	96 045 147 NFP CAG 6461 G7 CAD	96 045 099 NFP	95 230 684
R12 Ess 05/91 →	6453 H8	6453 GL		6455 L1	6461 94 CAG 6461 G7 CAD	96 109 484	96 090 004
R134 Ess	6453 N3	6453 GN		6455 T2	6461 A3 CAG 6461 G7 CAD	6455 T8	

NEUF : NEW - NUEVO - NOVO - NEU - NUOVO - NIEUW

E.S. ECHANGE STANDARD : STANDARD EXCHANGE - CAMBIO ESTANDARD - R.RENOVADO - AUSTAUSCH - REVISIONATO - FABRIEKSRIJL

CAG - CONDUITE A GAUCHE : LEFT HAND DRIVE - CONDUCCIÓN A IZQUIERDA - CONDUÇÃO À ESQUERDA - LINKSLENKUNG - GUIDA A SINISTRA - LINKSE BESTURING

CAD - CONDUITE A DROITE : RIGHT HAND DRIVE - CONDUCCIÓN A DERECHA - CONDUÇÃO À DIREITA - RECHTSLENKUNG - GUIDA A DESTRA - RECHTSE BESTURING

CITROËN SAXO

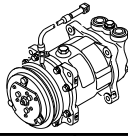
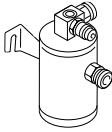
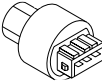
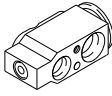
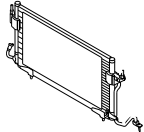
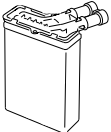
							
	Neuf	E.S.					
Ess TT Sauf 1,6 L - Sauf GPL	6453 N1 → 09/2000 6453 FS 09/2000 →	6453 GC → 09/2000 6453 JK 09/2000 →	6455 X4 → 08/99	6455 T2	6461 F7 → 04/96 6461 G2 RP 6461 H3 04/96 →	6455 V0 → 08/99	6448 72
Ess 1,6 L - GPL			6455 V1 → 08/99			6455 Z1 08/99 → 05/2000	
Ess TT			6455 Z0 09/99 →			6455 Z7 05/2000 → 02/2001	
DI			6455 X4 → 08/99 6455 Z0 09/99 →			6455 AG 02/2001 →	

NEUF : NEW - NUEVO - NOVO - NEU - NUOVO - NIEUW

E.S. ECHANGE STANDARD : STANDARD EXCHANGE - CAMBIO ESTANDARD - R.RENOVADO - AUSTAUSCH - REVISIONATO - FABRIKSRUIL



SAUF : EXEPT - SALVO - SALVO - AUSSER - SALVO - BEHALVE

GPL : LPG - GPL - GPL - GASANTRIEB - GPL - LPG



SAUF GPL : EXEPT LPG - SALVO GPL - SALVO GPL - AUSSER GASANTRIEB - SALVO GPL - BEHALVE LPG

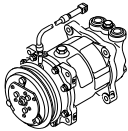
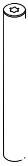
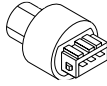
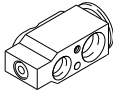
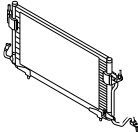

TT - TOUS TYPES - : ALL TYPES - TODOS LOS TIPOS - TODOS OS TIPOS - ALLE TYPEN - TUTTI I TIPI - ALLE TYPEN

	CITROËN C3
--	-------------------

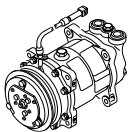
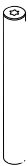
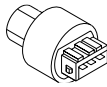
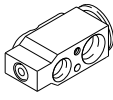
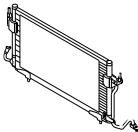
							
	Neuf	E.S.					
Ess - DI	6453 KS	-	6455 CF	6455 Z3	6461 H9	6455 AL	6448 K9

	CITROËN C3 PLURIEL
--	---------------------------

							
	Neuf	E.S.					
Ess - DI	6453 KS	-	6455 CF	6455 Z3	6461 H9	6455 AL	6448 K9

	
Ess - DI	6447 NT
Ess - DI	6447 NV Avec charbon actif

NEUF : NEW - NUEVO - NOVO - NEU - NUOVO - NIEUW

E.S. ECHANGE STANDARD : STANDARD EXCHANGE - CAMBIO ESTANDARD - R.RENOVADO - AUSTAUSCH - REVISIONATO - FABRIEKSRIJL

AVEC CHARBON ACTIF : WITH ACTIVE CARBON - CON CARBON ACTIVO - COM CARVAO ACTIVO - MIT AKTIVKOHLE - CON CARBONE ATTIVO - MET ACTIEVE KOOLSTOF

CITROËN ZX

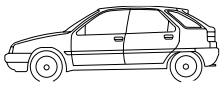
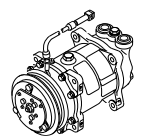
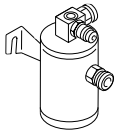
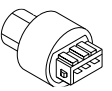
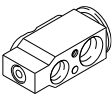
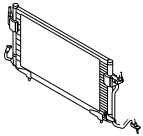
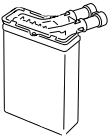
								
	Neuf	E.S.						
R12 (TU3.2) Ess 1,4 L Carbu	96 118 714 → 06/92 NFP	-	6455 Q4	6455 L1 → 09/91	6461 91 RP 6461 J2 Valéo	96 123 386	6448 78 CAG Valéo	
	96 168 213 07/92 →	-		96 143 907 09/91 →	95 663 104 Behr			
R134 (TU1-TU1M) Ess 1,1 L (TU3.2-TU3M-TU3JP) Ess 1,4 L (TU5JP) Ess 1,6 L (TUD3-TUD5) DI 1,4 L - 1,5 L	6453 N3	6453 GN		6455 T2	6461 A3 Valéo	6455 Q9 → 01/97		6448 C8 CAG Behr
					6461 97 Behr	6455 V9 RP 6455 AV 01/97 →		
R12 (XU5M-XU9JA-XU9JAZ) Ess 1,6 L - 1,9 L	6453 H6	6453 FZ		6455 L1 → 09/91	6461 91 RP 6461 J2 Valéo	96 123 386		6448 80 CAD Valéo
	95 659 531 Sans embrayage RP 6453 H6	-		96 143 907 09/91 →	95 663 104 Behr			
R134 (XU5JP-XU7JP-XU7JP4) Ess 1,6 L - 1,8 L - 1,8 L 16S (XU10J2-XU10J4-XU10J4RS) Ess 2 L - 2 L 16S (XUD7-XUD9) DI Atmo 1,8 L - 1,9 L	6453 P9	6453 GE		6455 T2	6461 A3 Valéo	6455 Q9 → 01/97		6448 80 CAD Valéo
					6461 97 Behr	6455 V9 RP 6455 AV 01/97 →		
R12 (XU7JP-XU10J2-XU10J4) Ess 1,8 L - 2 L - 2 L 16S (XUD7-XUD9) DI Atmo 1,8 L - 1,9 L	6453 K4	6453 GG		6455 L1 → 09/91	6461 91 RP 6461 J2 Valéo	96 123 386		6448 80 CAD Valéo
				96 143 907 09/91 →	95 663 104 Behr			
R134 (XU9JA-XU9JAZ) Ess 1,9 L	6453 P8	6453 GH	6455 T2	6461 A3 Valéo	6455 Q9 → 01/97	6448 80 CAD Valéo		
				6461 97 Behr	6455 V9 RP 6455 AV 01/97 →			
R12 (XUD9TE) DI Turbo 1,9 L	6453 K4	6453 GG	6455 L1 → 09/91	6461 91 RP 6461 J2 Valéo	96 147 839	6448 80 CAD Valéo		
			96 143 907 09/91 →	95 663 104 Behr				
R134 (XUD9TE) DI Turbo 1,9 L	6453 P9	6453 GE	6455 T2	6461 A3 Valéo	6455 R0			
				6461 97 Behr				

NEUF : NEW - NUEVO - NOVO - NEU - NUOVO - NIEUW

E.S. ECHANGE STANDARD : STANDARD EXCHANGE - CAMBIO ESTANDARD - R.RENOVADO - AUSTAUSCH - REVISIONATO - FABRIEKSRUIL

SANS EMBRAYAGE : WITHOUT CLUTCH - SIN EMBRAGUE - SEM EMBRAIAGEM - OHNE KUPPLUNG - SENZA FRIZIONE - ZONDER KOPPELING

CAG - CONDUITE A GAUCHE : LEFT HAND DRIVE - CONDUCCIÓN A IZQUIERDA - CONDUÇÃO À ESQUERDA - LINKSLENKUNG - GUIDA A SINISTRA - LINKSE BESTURING

CAD - CONDUITE A DROITE : RIGHT HAND DRIVE - CONDUCCIÓN A DERECHA - CONDUÇÃO À DIREITA - RECHTSLENKUNG - GUIDA A DESTRA - RECHTSE BESTURING

CITROËN XSARA → 27/08/2000

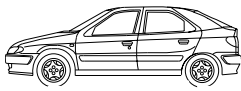
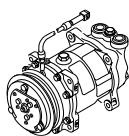
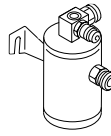
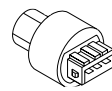
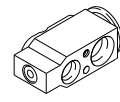
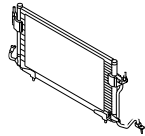
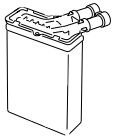
								
	Neuf	E.S.						
Ess 1,4 L - 1,6 L	6453 N1	6453 GC	6455 Q4 → 12/99	6455 T2	6461 G3 → 01/98 Réfri Régulée	6455 V9 RP 6455 AV	6448 78 CAG Valéo	
DI 1,5 L			6455 Z4 12/99 →			6455 X8	6455 W2 RP 6455 AW	6448 C8 CAG Behr
Ess Sauf 1,4 L - 1,6 L	6453 FE	6453 GA	6455 Q4 → 12/99			6461 H3 01/98 → Réfri Régulée	6455 V9 RP 6455 AV	6448 80 CAD Valéo
DI TT Sauf 1,5 L			6455 Z4 12/99 →			6455 Q4	6461 G9 Réfri Simple	6455 Y2

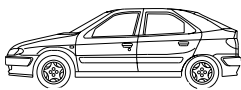
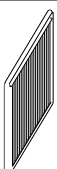
	
Ess - DI	6447 FG Réfri Simple
	6447 Z4 Réfri Régulée

NEUF : NEW - NUEVO - NOVO - NEU - NUOVO - NIEUW

E.S. ECHANGE STANDARD : STANDARD EXCHANGE - CAMBIO ESTANDARD - R.RENOVADO - AUSTAUSCH - REVISIONATO - FABRIEKSRIJL

CAG - CONDUITE A GAUCHE : LEFT HAND DRIVE - CONDUCCIÓN A IZQUIERDA - CONDUÇÃO À ESQUERDA - LINKSLENKUNG - GUIDA A SINISTRA - LINKSE BESTURING



CAD - CONDUITE A DROITE : RIGHT HAND DRIVE - CONDUCCIÓN A DERECHA - CONDUÇÃO À DIREITA - RECHTSLENKUNG - GUIDA A DESTRA - RECHTSE BESTURING

REFRI SIMPLE : SIMPLE AIRCOM - REFRI SIMPLE - REFRIGERAÇÃO SIMPLES - EINFACHE KLIMAAANLAGE - CLIMATIZZATORE MANUALE - BASIS AIRCO

REFRI REGULEE : AUTOMATIC AIRCOM - REFRI REGULADO - REFRIGERAÇÃO REGULADA - REGULIERTE KLIMAAANLAGE - CLIMATIZZATORE AUTOMATICO - TEMPERATUURGEREGELDE AIRCO

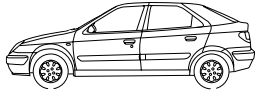
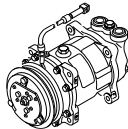
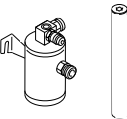
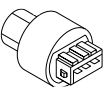
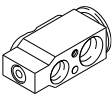
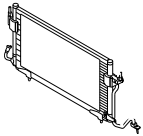
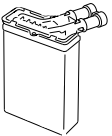
CITROËN XSARA 28/08/2000 →

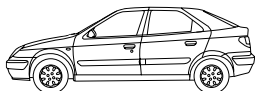
							
	Neuf	E.S.					
Ess 1,4 L - 1,6 L 16S → 12/2001	6453 FR SD6V12 1433	6453 JJ	6455 CE	6455 Z3	6461 G2 RP 6461 H3 Réfri Régulée	6455 Y9 RP 6455 AT	6448 78 CAG Valéo
	6453 JL SD6V12 1430	6453 JP					
Ess 1,4 L - 1,6 L 16S 12/2001 →	6453 LF	-					
(EW10J4) Ess 2L 16S → 12/2001	6453 EN SD6V12 1421	6453 JH					
	6453 JL SD6V12 1430	6453 JP					
(EW10J4) Ess 2L 16S 12/2001 →	6453 LF	-					
(XU10J4RS) Ess 2L 16S	6453 FE	6453 GA	6455 Z6			6455 V9 RP 6455 AV	6448 C8 CAG Behr
(DV4TD) DI Turbo 1,4 L HDi	6453 NK	-	6455 CE		6461 G9 Réfri Simple	6455 Y9 RP 6455 AT	6448 80 CAD Valéo
(DW8B) DI Atmo 1,9 L → 06/2001	6453 FE	6453 GA					
(DW10 - DW10ATED) DI Turbo 2 L HDi → 06/2001							
(DW8B) DI Atmo 1,9 L	6453 JN SD7V16 1228 06/2001 → 12/2001	6453 JQ					
(DW10TD) DI Turbo 2 L HDi							
(DW10ATED) FAP DI Turbo 2 L HDi							
(DW8B) DI Atmo 1,9 L (DW10ATED) Sans FAP DI Turbo 2 L HDi							
	6453 LQ SD7V16 1240 12/2001 →	-				6453 EC RP 6455 AS	6448 C9 CAD Behr
						6455 Y9 RP 6455 AT	
						6453 EC RP 6455 AS	

			
	Ess - DI	6447 FG Réfri Simple	6447 HP CAG - Réfri Régulée

NEUF : NEW - NUEVO - NOVO - NEU - NUOVO - NIEUW

E.S. ECHANGE STANDARD : STANDARD EXCHANGE - CAMBIO ESTANDARD - R.RENOVADO - AUSTAUSCH - REVISIONATO - FABRIEKSUIJL



CAG - CONDUITE A GAUCHE : LEFT HAND DRIVE - CONDUCCIÓN A IZQUIERDA - CONDUÇÃO À ESQUERDA - LINKSLENKUNG - GUIDA A SINISTRA - LINKSE BESTURING



CAD - CONDUITE A DROITE : RIGHT HAND DRIVE - CONDUCCIÓN A DERECHA - CONDUÇÃO À DIREITA - RECHTSLENKUNG - GUIDA A DESTRA - RECHTSE BESTURING

REFRI SIMPLE : SIMPLE AIRCOM - REFRI SIMPLE - REFRIGERAÇÃO SIMPLES - EINFACHE KLIMAAANLAGE - CLIMATIZZATORE MANUALE - BASIS AIRCO

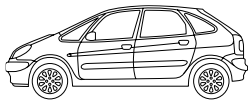
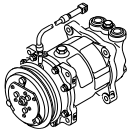
REFRI REGULEE : AUTOMATIC AIRCOM - REFRI REGULADO - REFRIGERAÇÃO REGULADA - REGULIERTE KLIMAAANLAGE - CLIMATIZZATORE AUTOMATICO - TEMPERATUURGEREGELDE AIRCO

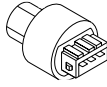
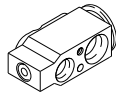
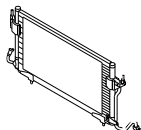
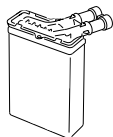
CITROËN XSARA PICASSO

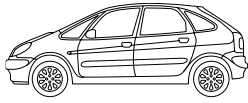
							
	Neuf	E.S.					
Ess 1,6 L	6453 CN → 12/2001	6453 JG	6455 CE	6455 X5	6461 G5 Réfri DAM 08365 FV →	6455 Y9 RP 6455 AT	6448 G3
Ess 1,6 L	6453 JL 12/2001 →	-					
Ess 1,8 L 16S - 2 L 16S DAM 08365 FV →	6453 EN → 11/2002	6453 JH					
	6453 LF 11/2002 →	-					
Ess 2 L 16S DAM 08834 78 →	6453 CL → DAM 09001 78	6453 JF					6448 L0
	6453 KT DAM 09002 78 →	-					
DI Turbo 2 L HDi DAM 08421 FV → DAM 09491 FV DAM 08852 78 → DAM 09027 78	6453 FE	6453 GA					6448 G3
DI Turbo 2 L HDi BSI COMM 2000 DAM 09492 FV →	6453 LQ	-	6448 L0				
DI Turbo 2 L HDi DAM 09027 78 →	6453 KV	6453 KZ					

	
Ess - DI	6447 FF
Ess - DI	6447 LN Avec charbon actif

NEUF : NEW - NUEVO - NOVO - NEU - NUOVO - NIEUW

E.S. ECHANGE STANDARD : STANDARD EXCHANGE - CAMBIO ESTANDARD - R.RENOVADO - AUSTAUSCH - REVISIONATO - FABRIEKSUIJL

AVEC CHARBON ACTIF : WITH ACTIVE CARBON - CON CARBON ACTIVO - COM CARVAO ACTIVO - MIT AKTIVKOHLE - CON CARBONE ATTIVO - MET ACTIEVE KOOLSTOF

REFRI ADDITIONNELLE : ADDITIONAL AIR CONDITIONING - AIRE ACONDICIONADO ADICIONAL - REFRI ADICIONAL - ZUSATKLIMANLAGE - REFRIGERATORE ADIZIONALE-
EXTRA AIRCO

CITROËN BX

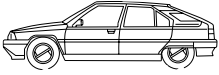
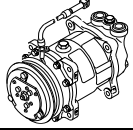
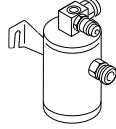
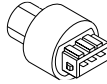
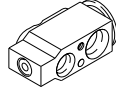
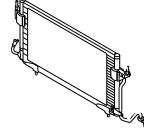
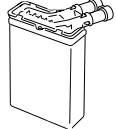

							
	Neuf	E.S.					
Ess - DI → 10/89	6453 H6	6453 FZ	6455 R1	95 496 899	6461 G7	95 634 991	95 495 316
Ess - DI 10/89 → Sauf GTI 16S Sauf DI Turbo Sauf 4x4	6453 H6	6453 FZ					
	95 659 531 Sans embrayage RP 6453 H6	-					
GTI 16S	6453 H6	6453 FZ					
	95 659 531 Sans embrayage RP 6453 H6	-					
DI Turbo	6453 H6	6453 FZ					
	95 659 531 Sans embrayage RP 6453 H6	-					

NEUF : NEW - NUEVO - NOVO - NEU - NUOVO - NIEUW

E.S. ECHANGE STANDARD : STANDARD EXCHANGE - CAMBIO ESTANDARD - R.RENOVADO - AUSTAUSCH - REVISIONATO - FABRIEKSUIJL

SANS EMBRAYAGE : WITHOUT CLUTCH - SIN EMBRAGUE - SEM EMBRAIAGEM - OHNE KUPPLUNG - SENZA FRIZIONE - ZONDER KOPPELING

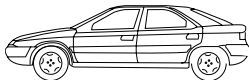
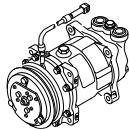
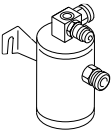
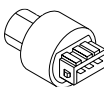
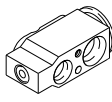
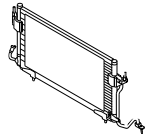
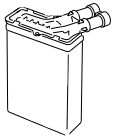
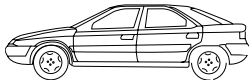
CITROËN XANTIA

								
	Neuf	E.S.						
Ess → 12/97 Sauf Ess Turbo 2 L - V6 DI → 12/97 Sauf DI Turbo 2,1 L	6453 FE (Sanden) SD7 V16 1106 SD7 V16 1227 SD7 V16 1218 SD7 V16 B068	6453 GA (Sanden) SD7 V16 1106 SD7 V16 1227	6453 Y5	6455 T2	95 667 989 (Sanden) SD7 V16 1106	6453 V5	6448 78 CAG Valéo 6448 C8 CAG Behr 6448 80 CAD	
(XU10J2TE) Ess Turbo 2 L → 12/97	6453 P9 (Sanden) SD7 H15 7854	6453 GE (Sanden) SD7 H15 7854	6453 V6		6461 F6 (Sanden) SD7 H15 7854			
Ess 12/97 → Sauf Ess Turbo 2 L	6453 FE (Sanden) SD7 V16 1106 SD7 V16 1218	6453 GA	6453 Y5		95 667 989			
(XU10J2TE) Ess Turbo 2 L 12/97 →			6453 V6					
(ES9J4) V6	6453 AX (Sanden) SD7 V16 1141 SD7 V16 1209	6453 GP	6453 Y5 → 12/97 6453 V6 12/97 →					
DI → 12/97 Sauf DI Turbo 2,1 L	6453 AQ (Harrison) Raccords à bride 6453 X7 (Harrison) Raccords vissés	6453 GF	6453 Y5					6461 G1
(XUD11BTE) DI Turbo 2,1 L → 12/97			6453 GY					
DI 12/97 → Sauf DI Turbo 2 L - 2,1 L	6453 AQ (Harrison) Raccords à bride	6453 GF	6453 Y5					
(XUD11BTE) DI Turbo 2,1 L 12/97 →			6453 V6					
(DW10) DI Turbo 2 L HDi 10/99 →								
(DW10) DI Turbo 2 L HDi 07/10/99 → 24/10/99	6453 FE (Sanden) SD7 V16 1106 SD7 V16 1227	6453 GA		95 667 989				
								
Ess - DI	6447 Z4							

NEUF : NEW - NUEVO - NOVO - NEU - NUOVO - NIEUW

E.S. ECHANGE STANDARD : STANDARD EXCHANGE - CAMBIO ESTANDARD - R.RENOVADO - AUSTAUSCH - REVISIONATO - FABRIKSRUIL

CAG - CONDUITE A GAUCHE : LEFT HAND DRIVE - CONDUCCIÓN A IZQUIERDA - CONDUÇÃO À ESQUERDA - LINKSLENKUNG - GUIDA A SINISTRA - LINKSE BESTURING

CAD - CONDUITE A DROITE : RIGHT HAND DRIVE - CONDUCCIÓN A DERECHA - CONDUÇÃO À DIREITA - RECHTSLENKUNG - GUIDA A DESTRA - RECHTSE BESTURING





RACCORDS A BRIDE : FLANGE ATTACHMENT - RACORES DE BRIDA - TUBO COM BRAÇADEIRA - FLANSCHVERBINDUNG - RACCORDI FLANGIATI - KOPPELSTUK

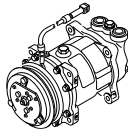

FLANSBEVESTIGING

RACCORDS VISSÉS : SCREW ATTACHMENT - RACORES DE ROSCA - TUBO COM PARAFUSOS - SCHRAUBVERBINDUNG - RACCORDI AVVITATI - KOPPELSTUK

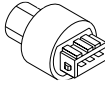
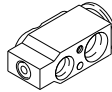
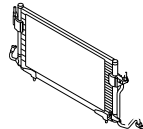
BOUTBEVESTIGING

CITROËN C5

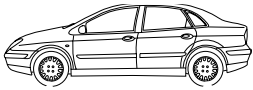
							
	Neuf	E.S.					
(EW7J4 - EW10J4 - EW10D) Ess 1,8 L - 2 L 16 S	6453 CL SD7 V16 1211 → 06/2002	6453 JF	6455 AJ			6453 FH	
	6453 NK SD7 V16 1242 06/2002 →	-					
(ES9J4) Ess 3 L V6	6453 AX SD7 V16 1209 SD7 V16 1141 → 06/2002	6453 GP	6455 AK			6453 FP	
	6453 NH SD7 V16 1243 06/2002 →	-					
(DW10TD - DW10ATED) DI Turbo 2 L HDi	6453 AQ → 12/2001	6453 GF	6455 AJ		6461 H2	6453 FH	6448 J8
	6453 LX 12/2001 → 06/2002	6453 LY					
	6453 LQ 06/2002 →	-					
(DW12TED4) DI Turbo 2,2 L 16 S HDi	6453 FE → 06/2002	6453 GA					
	6453 LQ 06/2002 →	-					

	
Ess - DI	6447 HT Réfri Simple
	6447 HV Réfri Régulée

NEUF : NEW - NUEVO - NOVO - NEU - NUOVO - NIEUW

E.S. ECHANGE STANDARD : STANDARD EXCHANGE - CAMBIO ESTANDARD - R.RENOVADO - AUSTAUSCH - REVISIONATO - FABRIEKSRUIL

REFRI SIMPLE : SIMPLE AIRCOM - REFRI SIMPLE - REFRIGERAÇÃO SIMPLES - EINFACHE KLIMAAANLAGE - CLIMATIZZATORE MANUALE - BASIS AIRCO

REFRI REGULÉE : AUTOMATIC AIRCOM - REFRI REGULADO - REFRIGERAÇÃO REGULADA - REGULIERTE KLIMAAANLAGE - CLIMATIZZATORE AUTOMATICO - TEMPERATUURGEREGELDE AIRCO

CITROËN XM

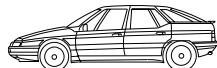
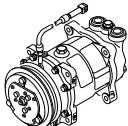
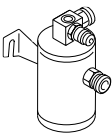
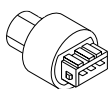
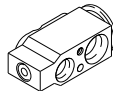
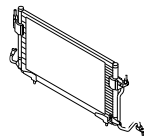
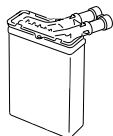

							
	Neuf	E.S.					
R12 Ess - DI → 09/93	6453 H6	6453 FZ	6453 Z0	R12 6455 L1 → 11/93	R12 6461 91 → 08/93	96 134 218	6448 89
R12 Ess - DI 09/90 → 07/91	95 659 531 Sans embrayage RP 6453 H6	-					
Ess 09/93 → 07/94	6453 P5	6453 GK					
DI 09/93 → 07/94	6453 P9	6453 GE					
Ess - DI 07/94 → Sauf XU10J2TE Sauf V6 - Sauf DI 2,5 L Sauf XUD11BTE	6453 P5 SD7 H15 7870	6453 GK					
	6453 P9 SD7 H15 7854	6453 GE					
(ZPJ-ZPJ4) Ess 3 L V6	6453 Q2	6453 GJ					
(ES9J4) Ess 3 L V6	6453 AX	6453 GP					
(XU10J2TE) Ess 2L Turbo (XUD11BTE) DI Turbo 2,1 L	6453 FE	6453 GA					
(DK5ATE) DI Turbo 2,5 L						6453 S0	
				R134A 6455 T2 11/93 →	6461 A1 (323302 ou 323352)	6453 P7 RP 6455 Y6	
					6461 A1 (323302 ou 323352)		
					6461 F7 (323335)		
					6461 A3 (323304)		



NEUF : NEW - NUEVO - NOVO - NEU - NUOVO - NIEUW

E.S. ECHANGE STANDARD : STANDARD EXCHANGE - CAMBIO ESTANDARD - R.RENOVADO - AUSTAUSCH - REVISIONATO - FABRIEKSRIJL

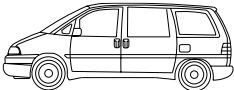
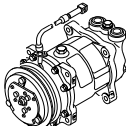
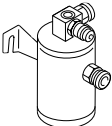
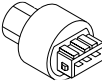
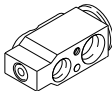
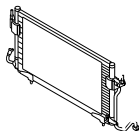
SANS EMBRAYAGE : WITHOUT CLUTCH - SIN EMBRAGUE - SEM EMBRAIAGEM - OHNE KUPPLUNG - SENZA FRIZIONE - ZONDER KOPPELING

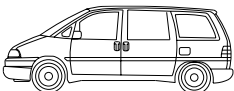

CITROËN EVASION



							
	Neuf	E.S.					
Ess - DI Sauf EW10J4	6453 FE	6453 GA	6455 Q7	6455 T2	6461 A1	6455 Y3	6448 A7
(EW10J4) Ess 2L 16 S	6453 CL	6453 JF					

	
Ess - DI	6447 H0 (1) Central 6447 H1 (2) Latéral - G/D

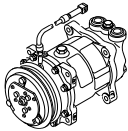
NEUF : NEW - NUEVO - NOVO - NEU - NUOVO - NIEUW
E.S. ECHANGE STANDARD : STANDARD EXCHANGE - CAMBIO ESTANDARD - R.RENOVADO - AUSTAUSCH - REVISIONATO - FABRIEKSRUIJ
CENTRAL : CENTRAL - CENTRAL - CENTRAL - ZENTRAL - CENTRALE - MIDDEN
LATERAL : LATERAL - LATERAL - LATERAL - SEITLICH - LATERALE - ZIJKANT
G - GAUCHE : LEFT - IZQUIERDO - ESQUERDO - LINKS - SINISTRA - LINKS
D - DROITE : RIGHT - DERECHO - DIREITO - RECHTS - DESTRA - RECHTS

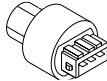
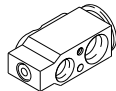
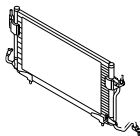
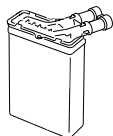
CITROËN C8

							
	Neuf	E.S.					
Ess Sauf ES9J4S	6453 CL SD7 V16 1211	-	-	6455 Z3	6461 H7	6455 AP	6448 K8
DI	6453 JN	-					
(ES9J4S) Ess 3 L V6	6453 AX SD7 V16 1209 SD7 V16 1141	-				6455 AQ	

	
Ess - DI	6447 LZ



NEUF : NEW - NUEVO - NOVO - NEU - NUOVO - NIEUW



E.S. ECHANGE STANDARD : STANDARD EXCHANGE - CAMBIO ESTANDARD - R.RENOVADO - AUSTAUSCH - REVISIONATO - FABRIEKSRIJL

REFRI SIMPLE : SIMPLE AIRCOM - REFRI SIMPLE - REFRIGERAÇÃO SIMPLES - EINFACHE KLIMAANLAGE - CLIMATIZZATORE MANUALE - BASIS AIRCO

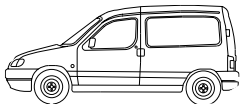
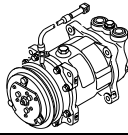
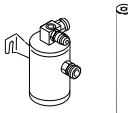
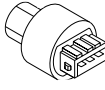
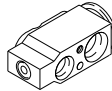
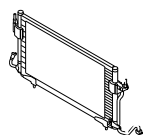
REFRI REGULEE : AUTOMATIC AIRCOM - REFRI REGULADO - REFRIGERAÇÃO REGULADA - REGULIERTE KLIMAANLAGE - CLIMATIZZATORE AUTOMATICO - TEMPERATUURGEREGELDE AIRCO

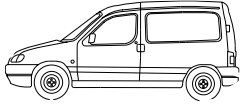

CITROËN BERLINGO (VP-VU)

							
	Neuf	E.S.					
(TU3.2) Ess 1,4 L	6453 N3 SD7 H13	6453 GN	6455 P8 → 07/99 6455 X8 07/99 →	6455 T2	6461 A3 SD7 H13	6455 Q9 → 06/97	6448 78 CAG
(TU1M-TU3JP-TU5JP4) Ess 1,1 L - 1,4 L - 1,6 L 16S	6453 N1 SD7 V12 → 09/2000	6453 GC → 09/2000				6455 V9 RP 6455 AV 06/97 →	
	6453 FS 09/2000 →	6453 JK 09/2000 →				6461 F9 SD7 V12 SD7 V16	
(XU7JB) Ess 1,8 L	6453 FE SD7 V16	6453 GA	6455 P8 → 07/99	6455 Y2 07/99 →			
(XUD7-XUD9-DW8-DW10) DI 1,8 L - 1,9 L - 2 L			6455 X7 07/99 →				
SA 18 ⚡							
Ess 11/2002 →	6453 LF SD6 V12 1438	-	6455 CE	6455 Z3	6461 F9	6455 AT	6748 78 CAG
DI 11/2002 →	6453 LQ SD7 V16 1240	-					6748 80 CAD

	
Ess - DI	6447 Z4 CAG → 12/2000 CAD
	6447 HP CAG 12/2000 →

NEUF : NEW - NUEVO - NOVO - NEU - NUOVO - NIEUW
 E.S. ECHANGE STANDARD : STANDARD EXCHANGE - CAMBIO ESTANDARD - R.RENOVADO - AUSTAUSCH - REVISIONATO - FABRIEKSRIJL
 CAG - CONDUITE A GAUCHE : LEFT HAND DRIVE - CONDUCCIÓN A IZQUIERDA - CONDUÇÃO À ESQUERDA - LINKSLENKUNG - GUIDA A SINISTRA - LINKSE BESTURING
 CAD - CONDUITE A DROITE : RIGHT HAND DRIVE - CONDUCCIÓN A DERECHA - CONDUÇÃO À DIREITA - RECHTSLENKUNG - GUIDA A DESTRA - RECHTSE BESTURING

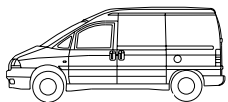
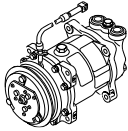
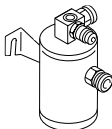
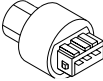
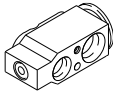
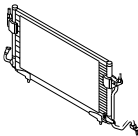
CITROËN JUMPY

							
	Neuf	E.S.					
Ess 1,6 L	6453 T8	6453 NV	6455 Q7	6455 T2	6461 A1	6455 Y3	6448 A7
Ess 2 L 16 S	6453 CL	6453 JF					
DI	6453 FE	6453 GA					



NEUF : NEW - NUEVO - NOVO - NEU - NUOVO - NIEUW

E.S. ECHANGE STANDARD : STANDARD EXCHANGE - CAMBIO ESTANDAR - R.RENOVADO - AUSTAUSCH - REVISIONATO - FABRIEKSUIJL

CAG - CONDUITE A GAUCHE : LEFT HAND DRIVE - CONDUCCIÓN A IZQUIERDA - CONDUÇÃO À ESQUERDA - LINKSLENKUNG - GUIDA A SINISTRA - LINKSE BESTURING

CAD - CONDUITE A DROITE : RIGHT HAND DRIVE - CONDUCCIÓN A DERECHA - CONDUÇÃO À DIREITA - RECHTSLENKUNG - GUIDA A DESTRA - RECHTSE BESTURING

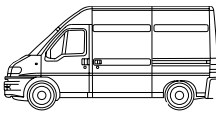
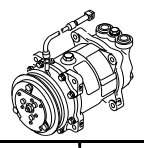
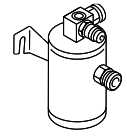
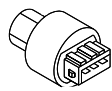
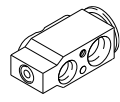
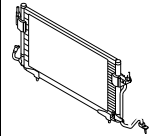
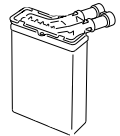
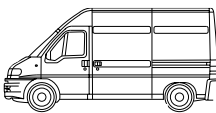
CITROËN JUMPER → 02/2002

								
	Neuf	E.S.						
(XU10J2-XU102C) Ess 2 L	6453 P9	6453 GE	6455 T4 RP 6455 AE	6455 T7 → S15741636 6455 Z5 S15741637 →	6461 E6 Réfri → 05/2000	6455 T3	6448 F9 CAG 6448 G0 CAD	
(XUD9-XUD9TE) DI Atmo 1,9 L DI Turbo 1,9 L					6461 C5 Réfri 05/2000 →			6461 C9 Réfri double
(DJ5-DJ5T-DJ5TED) DI Atmo 2,5 L DI Turbo 2,5 L					6461 E6 Réfri → S15741636			6461 C5 Réfri S15741637 →
(DW10TD) DI Turbo 2 L					6461 C9 Réfri double			6461 E6 Réfri → S15786574
(SOFIM) DI Atmo 2,8 L DI Turbo 2,8 L DI Turbo 2,8 L HDi					6461 C5 Réfri S15786575 →			6461 C9 Réfri double
	6453 T0	6453 GQ					6448 F9	
	6453 FE	6453 GA						
	6453 G5	-						
								
Ess - DI	6447 J0							

NEUF : NEW - NUEVO - NOVO - NEU - NUOVO - NIEUW

E.S. ECHANGE STANDARD : STANDARD EXCHANGE - CAMBIO ESTANDARD - R.RENOVADO - AUSTAUSCH - REVISIONATO - FABRIEKSRIJL





REFRI : AIR CONDITIONING - AIRE ACONDICIONARD - REFRI - EINFACHE KLIMA - REFRIGERAZIONE - AIRCO

REFRI DOUBLE : DOUBLE AIR CON - AIRE ACONDICIONADO DOBLE - REFRI DUPLO - DOPPELKLIMAAANLAGE - DOPPIA REFRIGERAZIONE - DUBBELE AIRCONDITIONING

CAG - CONDUITE A GAUCHE : LEFT HAND DRIVE - CONDUCCIÓN A IZQUIERDA - CONDUÇÃO À ESQUERDA - LINKSLENKUNG - GUIDA A SINISTRA - LINKSE BESTURING

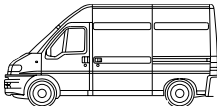
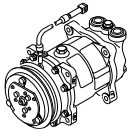
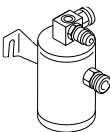
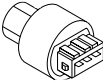
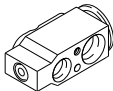
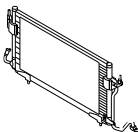
CAD - CONDUITE A DROITE : RIGHT HAND DRIVE - CONDUCCIÓN A DERECHA - CONDUÇÃO À DIREITA - RECHTSLENKUNG - GUIDA A DESTRA - RECHTSE BESTURING

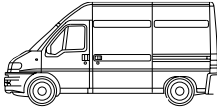
CITROËN JUMPER 02/2002 →

								
	Neuf	E.S.						
(XU10J2) Ess 2 L Sauf SOFIM	6453 FE	6453 GA	6455 AE	6455 Z5	6461 J1 Réfri CAG	6455 T3 → S 171265 75	6448 H8 CAG	
(DW10TD-DW12TED) DI Turbo 2 L - 2,1 L					6461 J4 Réfri double 6461 C5 CAD			6455 CG S 171265 76 →
(SOFIM) DI 2,8 L - 2,8 L HDi	6453 G5	-			6461 C5 Réfri			6461 J4 Réfri double
								
Ess - DI	6447 J0							

NEUF : NEW - NUEVO - NOVO - NEU - NUOVO - NIEUW

E.S. ECHANGE STANDARD : STANDARD EXCHANGE - CAMBIO ESTANDARD - R.RENOVADO - AUSTAUSCH - REVISIONATO - FABRIEKSRIJL

REFRI : AIR CONDITIONING - AIRE ACONDICIONARD - REFRI - EINFACHE KLIMA - REFRIGERAZIONE - AIRCO

REFRI DOUBLE : DOUBLE AIR CON - AIRE ACONDICIONADO DOBLE - REFRI DUPLIO - DOPPELKLIMANLAGE - DOPPIA REFRIGERAZIONE - DUBBELE AIRCONDITIONING

CAG - CONDUITE A GAUCHE : LEFT HAND DRIVE - CONDUCCIÓN A IZQUIERDA - CONDUÇÃO À ESQUERDA - LINKSLENKUNG - GUIDA A SINISTRA - LINKSE BESTURING

CAD - CONDUITE A DROITE : RIGHT HAND DRIVE - CONDUCCIÓN A DERECHA - CONDUÇÃO À DIREITA - RECHTSLENKUNG - GUIDA A DESTRA - RECHTSE BESTURING

CITROËN CX

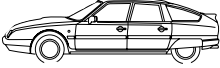
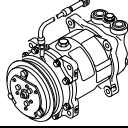
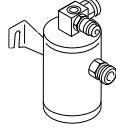
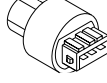
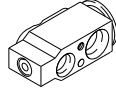
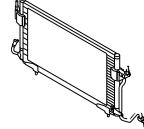
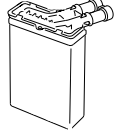
							
	Neuf	E.S.					
Ess - DI 07/83 → 07/85 Sauf Ess Turbo 2,5 L Sauf DI Turbo 2,5 L	95 601 937 RP 96 089 459	-	6455 R2 NFP	95 574 100 NFP	75 528 079 NFP	95 494 043 NFP Clim 95 493 388 NFP Super Clim 95 494 044 NFP BV Auto Super Clim	75 513 460
Ess Turbo 2,5 L 07/83 → 07/85 DI Turbo 2,5 L 07/83 → 07/85						95 495 928	
Ess - DI 07/85 → Sauf Ess Turbo 2,5 L Sauf DI Turbo 2,5 L	96 089 459	-	6455 R2 NFP	95 574 100 NFP	75 528 079 NFP	95 494 043 NFP Clim 95 494 044 NFP Clim très chaud	75 513 460 Sauf Pays Froids 75 524 692 NFP Pays Froids
Ess Turbo 2,5 L 06/81 → 07/85 DI Turbo 2,5 L 06/81 → 07/85						95 495 928 Clim 95 494 044 NFP Clim très chaud	

NEUF : NEW - NUEVO - NOVO - NEU - NUOVO - NIEUW

E.S. ECHANGE STANDARD : STANDARD EXCHANGE - CAMBIO ESTANDARD - R.RENOVADO - AUSTAUSCH - REVISIONATO - FABRIEKSRUIJ

CLIM : A/C - CLIMATIZACION - CLIM - KLIMAANLAGE - CLIM - AIRCONDITIONING

SUPER CLIM : SUPER A/C - SUPER CLIMATIZACION - SUPER CLIM - SUPER KLIMAANLAGE - SUPER CLIM - DUBBELE AIRCONDITIONING

CLIM TRES CHAUD : A/C VERY HOT COUNTRIES - PAISES MUY CALIDOS - CLIM MUITO QUENTE - KLIMAANLAGE SEHR HEISSELAENDER - CLIM MOLTO CALDO -







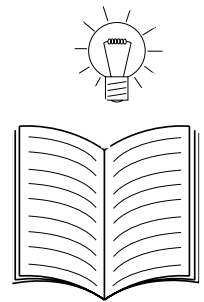
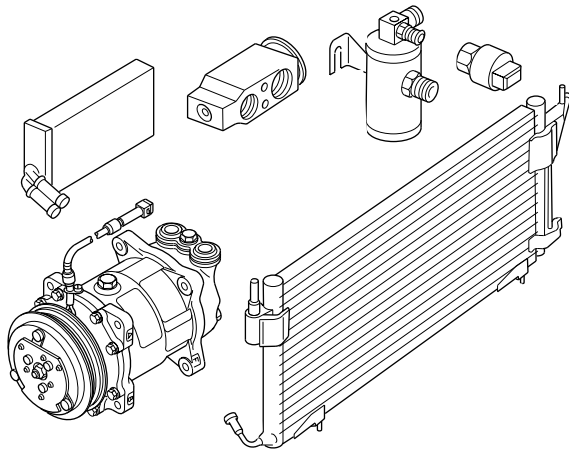

AIRCONDITIONING WARME LANDE

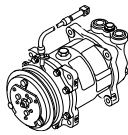
PAYS FROIDS : COLD COUNTRIES - PAISES FRIOS - PAISES FRIOS - NORDISCHE LAENDER - PAESI FREDDI - KOUDE LANDE

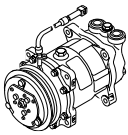
SAUF PAYS FROIDS : EXCEPT COLD COUNTRIES - SALVO PAISES FRIOS - SALVO PAISES FRIOS - AUSSER NORDISCHE LAENDER - SALVO PAESI FREDDI - BEHALVE KOUDEN

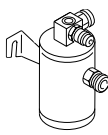
LANDE

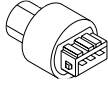

							
6453 AQ	13-15	6453 NH	14	6453 S0	15	6455 L1	5-8-15
6453 AX	13-14-15-17	6453 NV	19	6453 V6	13	6455 T2	5-6-8-9-13
6453 CL	11-14-16-17-19	6453 P5	15	6453 Y5	13		15-16-18-19
6453 CN	11	6453 P8	8	6453 Z0	15	6455 T7	20
6453 EN	8-9	6453 P9	8-13-15-20	6455 AE	20-21	6455 X5	11
6453 FE	9-10-11-13-14-15	6453 Q2	15	6455 AJ	14	6455 Z3	7-10-14-17-18
	16-18-19-20-21	6453 T0	20	6455 AK	14	6455 Z5	20-21
6453 FR	10	6453 T8	19	6455 CE	10-11-18	95 496 899	12
6453 FS	6-18	6453 X7	13	6455 CF	7	95 574 100	22
6453 FZ	8-12-15	95 601 937	22	6455 P8	18	96 045 108	5
6453 G5	20-21	95 659 531	8-12-15	6455 Q4	8-9	96 143 907	8
6453 GA	9-10-11-13-14-15	96 045 096	5	6455 Q7	16-19		
	16-18-19-20-21	96 089 459	22	6455 R1	5-12		
6453 GC	6-9-18	96 118 714	8	6455 R2	22		
6453 GE	8-13-15-20	96 168 213	8	6455 T4	20		
6453 GF	13-14			6455 V1	6		
6453 GG	8			6455 X4	6		
6453 GH	8			6455 X7	18		
6453 GJ	15			6455 X8	9-18		
6453 GK	15			6455 Z0	6		
6453 GL	5			6455 Z4	9		
6453 GN	5-8-18			6455 Z6	10		
6453 GP	13-14-15						
6453 GQ	20						
6453 GY	13						
6453 H6	8-12-15						
6453 H8	5						
6453 JF	11-14-16-19						
6453 JG	11						
6453 JH	10-11						
6453 JJ	10						
6453 JK	6-18						
6453 JL	10-11						
6453 JN	10-17						
6453 JP	10						
6453 JQ	10						
6453 K4	8						
6453 KS	7						
6453 KT	11						
6453 KV	11						
6453 KZ	11						
6453 LF	10-11-18						
6453 LQ	10-11-14-18						
6453 LX	14						
6453 LY	14						
6453 N1	6-9-18						
6453 N3	5-8-18						
6453 NK	10-14						

 Pour connaître les dernières dates de mise à jour, voir DOC FLASH : DIF/DOC/MKSP

DROITS DE PROPRIETE

F "Les droits de propriété intellectuelle relatifs aux informations techniques contenues dans cette brochure appartiennent exclusivement au Constructeur. Toute reproduction et/ou diffusion de tout ou partie de ces informations sont interdites sans autorisation écrite préalable du Constructeur."
 "Les informations techniques contenues dans la présente documentation sont destinées exclusivement aux professionnels de la réparation automobile. Dans certains cas, ces informations peuvent concerner la sécurité des véhicules. Elles seront utilisées par les réparateurs automobiles auxquels elles sont destinées, sous leur entière responsabilité, à l'exclusion de celle du Constructeur."
 "Les informations techniques figurant dans cette brochure peuvent faire l'objet de mises à jour en fonction de l'évolution des caractéristiques des modèles de chaque gamme.
 Nous invitons les réparateurs automobiles à se mettre en rapport périodiquement avec le Constructeur/avec son réseau, pour se procurer les mises à jour nécessaires."

 To see the latest update refer to DOC FLASH : DIF/DOC/MKSP

PROPERTY RIGHTS

GB "The intellectual copyrights relating to the technical information contained in this brochure are the exclusive property of the Manufacturer. Any reproduction and/or distribution of all or part of this information is forbidden without the Manufacturer's preliminary written authorisation."
 "The technical information contained in this documentation is intended exclusively for automobile repair professionals. In certain cases, the information may relate to vehicle safety.
 It will be used by the automobile repairers to whom it is addressed, on their full responsibility, to the exclusion of the Manufacturer's liability."
 "The technical information that figures in this brochure may be updated in accordance with the changing features of models in each range.
 We would request automobile repairers to get in touch with the Manufacturer/the network at regular intervals, to obtain the necessary updates."

 Para conocer las últimas fechas de puesta al día, ver DOC FLASH : DIF/DOC/MKSP

DERECHOS DE PROPIEDAD

E "Los derechos de propiedad intelectual relativos a las informaciones técnicas que figuran en este folleto pertenecen exclusivamente al Constructor. Se prohíbe toda reproducción y/o difusión de la totalidad o parte de estas informaciones sin autorización previa y por escrito del Constructor."
 "Las informaciones técnicas que figuran en la presente documentación están destinadas exclusivamente a los profesionales de la reparación de automóviles. En ciertos casos, pueden afectar a la seguridad de los vehículos.
 Serán utilizadas por los reparadores de automóviles, a quienes están destinadas, bajo su entera responsabilidad, excluyéndose la del Constructor."
 "Las informaciones técnicas que figuran en este folleto pueden ser objeto de actualizaciones en función de la evolución de las características de los modelos de cada gama.
 Invitamos a los reparadores de automóviles a ponerse en contacto periódicamente con el Constructor/con su red, para conseguir las actualizaciones necesarias."

 Para saber as últimas datas de actualizaçã, ver DOC FLASH : DIF/DOC/MKSP

DIREITOS DE PROPRIEDADE

P "Os direitos de propriedade intelectual relativos às informações técnicas contidas nesta brochura pertencem exclusivamente ao Construtor. Qualquer reprodução e/ou difusão da totalidade ou parte destas informações são proibidas sem a autorização prévia e escrita do Construtor."
 "As informações técnicas contidas na presente documentação destinam-se exclusivamente aos profissionais da reparação automóvel. Em certos casos, estas informações podem referir-se à segurança dos veículos.
 Serão utilizadas pelos reparadores automóvel a que se destinam, sob a sua total responsabilidade, excluindo a responsabilidade do Construtor."
 "As informações técnicas que figuram nesta brochura podem ser objecto de actualizações consoante a evolução das características dos modelos de cada gama.
 Os reparadores automóvel são convidados a entrarem periodicamente em contacto com o Construtor/com a sua rede, para obterem as actualizações necessárias."

 Die Daten der aktuellen Ausgaben finden Sie in : DOC FLASH : DIF/DOC/MKSP

EIGENTUMSRECHTE

D "Die Rechte auf geistiges Eigentum in Verbindung mit den in der vorliegenden Broschüre enthaltenen technischen Informationen stehen ausschließlich dem Hersteller zu. Jede vollständige oder teilweise Reproduktion und/oder Verbreitung dieser Informationen sind ohne vorherige schriftliche Genehmigung des Herstellers verboten."
 "Die in der vorliegenden Dokumentation enthaltenen technischen Informationen sind ausschließlich für Autoreparaturfachleute bestimmt. In einigen Fällen können diese Informationen die Sicherheit der Fahrzeuge betreffen.
 Sie werden von den Kraftfahrzeughandwerkern, für die sie bestimmt sind, in ihrer eigenen Verantwortung benutzt, unter Ausschluss der Verantwortung des Herstellers."
 "Die in dieser Broschüre enthaltenen technischen Informationen können je nach Fortentwicklung der verschiedenen Modelle in jeder Produktreihe aktualisiert werden.
 Wir fordern die Kraftfahrzeughandwerker auf, sich regelmäßig an den Hersteller/an sein Vertriebsnetz zu wenden, um sich die erforderlichen Aktualisierungen zu beschaffen".

 Per conoscere l'ultima data agglomerato vedere DOC FLASH : DIF/DOC/MKSP

DIRITTI DI PROPRIETÀ

I "I diritti di proprietà intellettuale riguardanti le informazioni tecniche contenute nel presente manuale appartengono esclusivamente al Costruttore. Qualsiasi riproduzione e/o diffusione di tutto o parte di queste informazioni sono vietate senza autorizzazione preventiva scritta del Costruttore."
 "Le informazioni tecniche contenute nella presente documentazione sono destinate esclusivamente agli autoriparatori. In alcuni casi, queste informazioni possono riguardare la sicurezza dei veicoli.
 Esse verranno utilizzate dagli autoriparatori ai quali esse sono destinate sotto la loro piena responsabilità, ad esclusione di quella del Costruttore."
 "Le informazioni tecniche contenute nel presente manuale possono essere oggetto ad aggiornamenti in funzione dell'evoluzione delle caratteristiche dei modelli di ogni gamma.
 Invitiamo gli autoriparatori a mettersi in contatto periodicamente con il Costruttore/la sua rete, per procurarsi gli aggiornamenti necessari."

 Voor de laatste versiedatum, zie DOC FLASH : DIF/DOC/MKSP

EIGENDOMSRECHT

O "Het individuele eigendomsrecht betreffende technische informatie die in deze brochure staat vermeld behoort exclusief aan de Fabrikant. Alle reproductie en/of verspreiding van alles of een gedeelte van deze informatie is verboden zonder voorafgaande, schriftelijke toestemming van de Fabrikant."
 "De technische informatie die in deze documentatie staat vermeld is alleen bestemd voor vakmensen in de branche van de automobielreparatie. In bepaalde gevallen kan deze informatie betrekking hebben op de veiligheid van de wagens.
 Deze wordt gebruikt door automobielreparateurs waarvoor zij is bestemd, onder hun volledig verantwoordelijkheid, waardoor die van de Fabrikant vervalt."
 "De technische informatie die in deze brochure staat vermeld kan onderhevig zijn aan aanvullingen als gevolg van een ontwikkeling in de technische gegevens van de modellen van elke serie.
 Wij vragen de automobielreparateurs zich regelmatig met de Fabrikant of zijn netwerk in verbinding te stellen, om deze noodzakelijke aanvullingen te verkrijgen."