







FREINAGE

EDITION 11/2003 - Cat 14.717

CITROËN



**FICHE QUALITE DES EDITIONS CATALOGUE PIECES AUTO
AMENDMENT REQUEST QUALITY FORM PARTS CATALOGUE
FICHA CALIDAD DE LAS EDICIONES CATALOGOS PIEZAS AUTO
FICHA QUALIDADE EDIÇÕES CATÁLOGOS PEÇAS AUTO
QUALITÄTS-DATENBLATT KATALOGAUSGABEN KFZ-TEILE
SCHEMA QUALITÀ DELLE EDIZIONI CATALOGHI PEZZI AUTO
KWALITEITSFICHE ONDERDELENCATALOGUS**

EXPEDITEUR / SENDER	DESTINATAIRE / RECIPIENT
SOCIETE / COMPANY :	CITROËN / DSPC / MKSP
NOM / NAME :	NOM / NAME : Didier PAPILLAUD
 _____	 01.58.79.73.95
 _____	 didier.papillaud@mpsa.com
 _____	

N° CAT 14. . . .

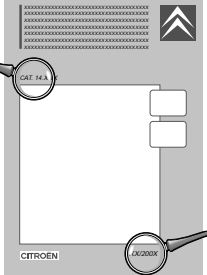

. . . / 200 .

ANOMALIE / CORRECTION / ANOMALIA / ANOMALIA / ANOMALIEN / ANOMALIA / FOUNT



SUGGESTION / SUGGESTION / SUGERENCIA / SUGESTÃO / VORSCHLÄGE / SUGGERIMENTO / SUGGESTIE



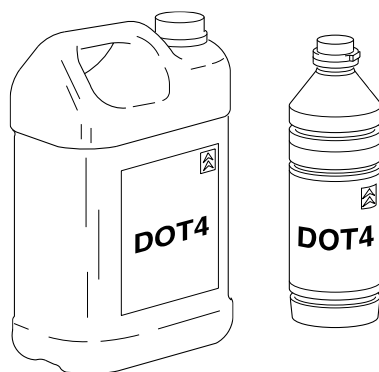

















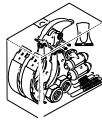



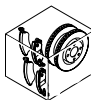





BP	Réf : 9979.86 (GB, D, GR, DK)	0,25L	UC20
	9979.88	0,5L	UC24
	9979.06	1L	UC1
	9979.07	5L	UC1
DOW	Réf : 9979.60	0,5L	UC24
	9979.62	5L	UC4

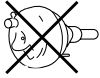

Réf : ZCP 830 095	1L	UC20
Réf : 9979.20 (N), (SF), (S)	1L	UC20











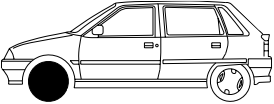
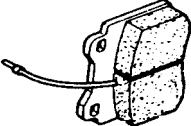

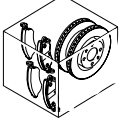
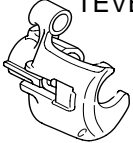

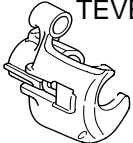
	(F)	(GB)	(E)
	ANTI-BLOCAGE ROUE	ABS (ANTI LOCK BRAKES)	ANTI-BLOQUEO RUEDA
	ARRIERE	REAR	TRASERO
	AVANT	FRONT	DELANTERO
	AVEC ASSISTANCE DE FREINAGE	WITH BRAKE SERVO	CON SERVO FRENO
	AVEC LIMITEUR	WITH BRAKE PRESSURE LIMITERS	CON LIMITADOR DE FRENO
	CABLE DE FREIN A MAIN	HANDBRAKE CABLE	CABLE DE FRENO MANO
	CYLINDRE DE ROUES	WHEEL CYLINDER	CILINDRO DE RUEDA
	2 DISQUES DE FREINS	2 BRAKES DISCS	2 DISCOS DE FRENO
	DISQUE DE FREINS	BRAKE DISC	DISCO DE FRENO
	ELECTRIQUE	ELCTRIC	ELECTRICO
	ENSEMBLE SEGMENTS + CYLINDRES	SET OF SHOES AND CYLINDERS	JUEGO ZAPATAS + CILINDROS
E	EPAISSEUR	THICKNESS	ESPESOR
	ETRIER DE FREIN	BRAKE CALIPER	ESTRIBO DE FRENO
	FREIN A MAIN	HANDBRAKE	FRENO DE MANO
	KIT DE FREINAGE PRE-MONTE	PRE-ASSEMBLED BRAKING KIT	CONJUNTO DE FRENOS PRE-MONTADO
	KIT PLAQUETTES ET DISQUES DE FREIN	BRAKE PADS AND DISCS KIT	KIT PLAQUETAS Y DISCOS DE FRENO
M	LIQUIDE DE FREIN MINERAL	MINERAL-BASED BRAKE FLUID	LIQUIDO DE FRENOS MINERAL

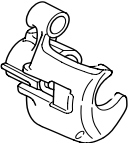

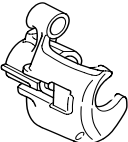

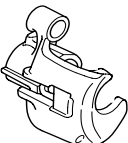

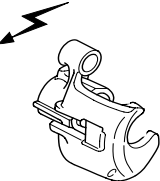



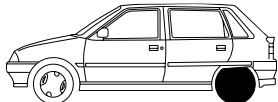
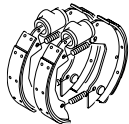
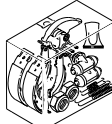

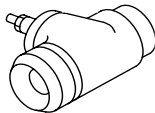
P	D	I	NL
ANTI BLOCAJEM DE RODA	ANTIBLOCKIERSYSTEM	ANTIBLOCCAGIO RUOTA	ANTIBLOKKEERSYSTEM
TRAS	HINTEN	POSTERIORE	ACHTER
FRENTE	VORN	ANTERIORE	VOOR
COM SERVO FREIO	MIT BREMSKRAFT- VERSTÄRKER	CON SERVOFRENO	MET REMBEKRACHTER
CON LIMITADOR DE TRAVAO	MIT BREMSKRAFTBEGRENZER	CON LIMITATORE DI FRENATA	MET REMBEGRENZER
CABO TRAVÃO DE MÃO	HANDBREMSSEIL	CAVO FRENO A MANO	HANDREMKABEL
CILINDRO DE RODAS	RADBREMSZYLINDER	CILINDRO FRENO	WIELREMCILINDER
2 DISCOS DE TRAVAO	2 BREMSSCHEIBEN	2 DISCI PER FRENI	2 REMSCHIJVEN
DISCO DE TRAVAO	BREMSSCHEIBE	DISCO PER FRENI	REMSEGMENTEN
ELECTRICO	ELEKTRISCH	ELETTRICO	ELECTRISCH
CONJUNTO SEGMENTOS + CILINDROS	SATZ BREMSBACKEN + RADBREMSZYLINDER	COMPLESSIVO SEGMENTI + CILINDRETTI	MET REMBEGRENZER
ESPESSURA	STÄRKE	SPESSORE	DIKTE
ESTRIBO DE TRAVÕES	BREMSSEL	PORTACEPPI FRENO	REMCLAUW
TRAVAO DE MAO	HANDBREMSE	FRENO A MANO	HANDREM
KIT DE TRAVÕES PRE-MONTADO	VORMONTIERTER BREMSSENZATZ	KIT PRE-MONTATO PER FRENI	VOORGEMONTEERDE KIT VOOR REMMEN
JOGO DE PLACAS E DISCOS DE TRAVAO	SATZ BREMSBELÄGE UND BREMSSCHEIBEN	INSIEME PIASTRE E DISCHI FRENO	REMBLOKSETS EN SCHIJFREMSSETS
LIQUIDO DE TRAVAO MINERAL	MINERALOGISCHE BREMSFLÜSSIGKEIT	LIQUIDO MINERALE PER FRENI	MINERALE REMVLOEISTOF

	(F)	(GB)	(E)
	LIQUIDE DE FREIN SYNTHETIQUE	SYNTHETIC BRAKE FLUID	LIQUIDO DE FRENOS SINTETICO
	MONTAGE TAMBOUR	TO INSTALL WITH BRAKE DRUM	MONTAJE CON TAMBOR DE FRENO
	PLAQUETTES DE FREINS	BRAKE PADS	PLAQUETAS DE FRENO
	ROUE FIXATION 3 TROUS	WHEEL WITH 3 BOLT FIXINGS	DISCO DE RUEDA CON 3 TALADROS FIJACION
	ROUE FIXATION 4 TROUS	WHEEL WITH 4 BOLT FIXINGS	DISCO DE RUEDA CON 4 TALADROS FIJACION
	SANS ASSISTANCE DE FREINAGE	WITHOUT BRAKE SERVO	SIN SERVO FRENO
	SANS LIMITEUR	WITHOUT BRAKE PRESSURE LIMITERS	SIN LIMITADOR DE FRENO
	SANS SUSPENSION HYDRACTIVE	WITHOUT SUSPENSION HYDRACTIVE	SIN SUSPENSION HIDRACTIVA
	SAUF	EXCEPT	SALVO
	SAUF ANTI-BLOPAGE ROUE	EXCEPT ABS (ANTI LOCK BRAKES)	SALVO ANTI- BLOQUEO RUEDA
	SEGMENTS DE FREINS	BRAKE SHOES	ZAPATAS DE FRENO
	SE REPORTER A LA MICROFICHE	REFER TO THE MICRO-FILM	REMIRTISE A LA MICROFICHA
	SUSPENSION HYDRACTIVE	SUSPENSION HYDRACTIVE	SUSPENSION HIDRACTIVA
TT	TOUS TYPES	ALL TYPES	TODOS LOS TIPOS

P	D	I	NL
LIQUIDO DE TRAVAO SINTETICO	SYNTETHISCHE BREMSFLÜSSIGKEIT	LIQUIDO SINTETICO PER FRENI	SYNTHETISCHE REMVLOEISTOF
MONTAGEM TAMBOR	MONTAGE MIT BREMSTROMMEL	MONTAGGIO CON TAMBURO FRENI	MONTAGE MET REMTROMMEL
PLACAS DE TRAVAO	BREMSBELÄGE	PASTIGLIE PER FRENI	REMBLOKKEN
RODA 3 PARAFUSOS	3 LOCH FELGE	RUOTA FISSAGGIO 3 FORI	WIEL BEVESTIGING 3 GATEN
RODA 4 PARAFUSOS	4 LOCH FELGE	RUOTA FISSAGGIO 4 FORI	WIEL BEVESTIGING 4 GATEN
SEM SERVO FREIO	OHNE BREMSKRAFT- VERSTÄRKER	SENS SERVOFRENO	ZONDER REMBEKRACHTER
SEM LIMITADOR DE TRAVAO	OHNE BREMSKRAFTBEGRENZER	SENZA LIMITATORE DI FRENATA	ZONDER REMBEGRENZER
SEM SUSPENSÃO HIDRACTIVA	OHNE HYDRACTIV FEDERUNG	SENZA SOSENSIONE DELL'IDRATTIVA	ZONDER VERING HYDRACTIEF
SALVO	AUSSER	SALVO	BEHALVE
SALVO ANTI-BLOQUEIO RODA	OHNE ABS	SENZA ABS	ZONDER ABS
SEGMENTO DE TRAVÕES	TROMMELBREMS- BACKEN	GANASCE	REMSEGMENTEN
CONSULTAR A MICROFICHA	SIEHE MIKROFILM	RIFERIRSI ALLA MICRO-SCHEDA	ZIE MICROFICHE
SUSPENSÃO HIDRACTIVA	HYDRACTIV FEDERUNG	SOSENSIONE DELL'IDRATTIVA	VERING HYDRACTIEF
TODOS OS TIPOS	ALLE TYPEN	TUTTI I TIPI	ALLE TYPEN

CITROËN AX

CITROËN AX				
				
<p>Ess (Sauf GTI - Sauf 4x4) 1 L 1,1 L 1,4 L DI } → 04/91</p>	 TEVES 95 650 937 → 10/90	95 658 617 10/90 →	 95 661 810 (Ø 238 E8)	4246 X0 → 15/10/90
<p>GT Sport</p>	 TEVES 95 650 938 → 10/90	95 658 617 10/90 →	 95 661 848 (Ø 238 E10) GT → 01/89 Sport → 01/88	–
 TEVES	95 658 617 10/90 → 04/91	 95 669 226 (Ø258E10) GT 01/89 → 04/91 Sport → 01/88	 95 669 226 (Ø258E10) GT 01/89 → 04/91 Sport → 01/88	–
<p>1,4 L Sauf IE GT DI 4 x 4 } 04/91 →</p>  BENDIX	95 666 970	 95 661 811 (Ø 247 E10)	 95 661 811 (Ø 247 E10)	–
<p>IE</p>  GIRLING	95 661 871	 95 661 747 (Ø 247 E20,4)	 95 661 747 (Ø 247 E20,4)	–
 TEVES	4251 28	 95 661 810 (Ø 238 E8)	 95 661 810 (Ø 238 E8)	–

				CITROËN AX		
						
TT → 04/91 Sauf 1,4 IE Sauf 4 x 4		4241 5X *	95 656 502 ** NFP	95 619 515 * 95 653 213 ** 95 655 344 ***	• Gauche	•• Droit
		4241 5W ***	—		95 608 853 (1)	95 608 854 (1)
Ess 1,0 L - 1,1 L 04/91 → Sauf ENTREPRISE Sauf IE - Sauf 4 x 4		4241 5X *	—	95 619 515 *	95 608 853 (1)	95 608 854 (1)
		4241 5W ***	—		95 619 515 *	4402 95 (2)
Ess 1,4 L - DIESEL 04/91 → Sauf ENTREPRISE Sauf IE - Sauf 4 x 4		—	95 666 935 ***	95 655 344 ***	95 608 853 (1)	95 608 854 (1)
		4241 5W ***	—		95 619 515 *	4402 95 (2)
Ess 1,0 L - 1,1 L ENTREPRISE 04/91 →		—	95 666 842	4241 J6	4402 93 (1)	4402 94 (1)
		4241 5W ***	95 666 843		95 659 668 (2)	95 659 668 (2)
4 x 4	—	95 666 841	95 659 661	95 659 664 (1)	95 659 665 (1)	
	—	—	4241 E7	4402 95 (2)		

ATTENTION : LORS D'UN ECHANGE DES SEGMENTS DE FREIN IL EST IMPERATIF DE RESPECTER LA MONTE SERIE EN SE REFERANT AU REPERE ETIQUETTE SUR LE PLATEAU DE FREINAGE

WARNING : WHEN REPLACING THE BRAKE SHOES IT IS ESSENTIAL THAT YOU CHECK THE REFERENCE INDICATED ON THE BRAKE BACK PLATE

ATENCION : CUANDO SE CAMBIEN LA ZAPATAS DE FRENO ES IMPERATIVO RESPETAR EL MONTAJE DE SERIE CON SU INDICACION O MARCA ETIQUETADA SOBRE EL PLATO DE FRENO

ATENÇÃO : NA MUDANÇA DOS SEGMENTOS DE TRAVÃO É IMPERATIVO RESPEITAR A MONTAGEM DE SÉRIE REFERINDO-SE À MARCAÇÃO DE ETIQUETA NO PRATO DE TRAVÃO

ACHTUNG : BEIM AUSTAUSCH DER BREMSBACKEN MUSS UNBEDINGT DIE VORHANDENE SERIENMONTAGE EINGEHALTEN WERDEN. HIERZU IST DIE MARKIERUNG AN DER BREMSTRAGPLATTE ZU BEACHTEN

ATTENZIONE : IN OCCASIONE DEL CAMBIO DEI SEGMENTI FRENI E' IMPERATIVO RISPETTARE IL MONTAGGIO SERIE RIFERENDOSI AL SEGNO DI RIFERIMENTO ETICHETTA SUL PIATTO DI FRENATA

LET OP : BIJ HET MONTEREN VAN NIEUWE REMDELEN, DIENT U ZICH TE HOUDEN AAN DE EERSTE MONTAGE. HET BIJBEHORENDE MERKTEKEN STAAT VERMELD OP DE REMANKERPLAAT

* **ENERGIT SANS ETIQUETTE** : ENERGIT WITHOUT LABEL - ENERGIT SIN ETIQUETA - ENERGIT SEM ETIQUETA - ENERGIT OHNE AUFKLEBER - ENERGIT SENZA ETICHETTA - ENERGIT ZONDER ETIKET









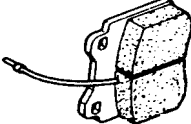

** **VALEO AVEC ETIQUETTE BLANCHE QUALITE F154** : VALEO WITH WHITE LABEL, QUALITY F154 - VALEO CON ETIQUETA BLANCA CALIDAD F154 - VALEO COM ETIQUETA BRANCA QUALIDADE F154 - VALEO WEISSER AUFKLEBER, AUFSCHRIFT F154 - VALEO CON ETICHETTA BIANCA QUALITA F154 - VALEO MET WIT ETIKET, KWALITEITSCODE F154

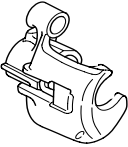
*** **ABEX**

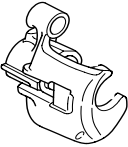
GAUCHE : LEFT - IZQUIERDO - ESQUERDO - LINKS - SINISTRA - LINKS

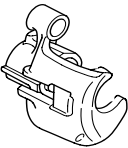



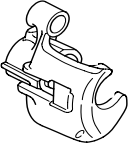



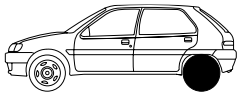
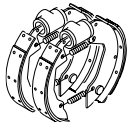

DROIT : RIGHT - DERECHO - DIREITO - RECHTS - DESTRA - RECHTS

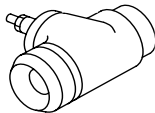
CITROËN SAXO

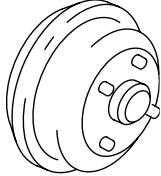
		
<p>TT</p>  <p>TEVES</p> <p>• Disques non ventilés</p>	<p>4251 28</p>	 <p>95 661 810 (Ø 238 E8)</p>
<p>TT</p>  <p>TEVES</p> <p>•• Disques ventilés</p>	<p>4251 39</p>	 <p>95 661 747 (Ø 247 E20,4)</p>
<p>Ess DI</p>  <p>BENDIX</p> <p>• Disques non ventilés</p>	<p>4251 37 deo + (1) 4427 87 → 06/03 RP 4252 72 deo + (1) 4427 87 4252 72 deo + (1) 4427 87 06/03 →</p> <p></p> <p>4251 47 deo + (1) 4427 87</p> <p></p>	 <p>95 661 748 (Ø 247 E10)</p>
<p></p>  <p>BENDIX</p> <p>• Disques non ventilés</p>	<p>4251 40 deo + (1) 4427 87 → 06/03 RP 4252 73 deo + (1) 4427 87 4252 73 deo + (1) 4427 87 06/03 →</p>	

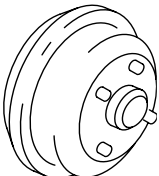
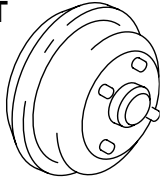

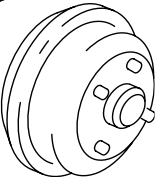
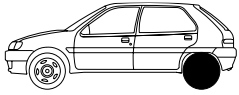
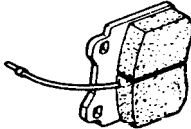



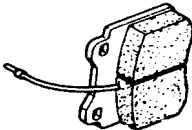

- **DISQUES NON VENTILES** : NON VENTILATED BRAKE DISC - DISCOS DE FRENO NO VENTILADO - DISCOS NÃO VENTILADOS - BREMSSCHEIBEN NICHT BELÜFTET - DISCHI FRENI NON VENTILATI - NIET GEVENTILEERDE REMSCHIJVEN
- **DISQUES VENTILES** : VENTILATED BRAKE DISC - DISCOS DE FRENO VENTILADO - DISCOS VENTILADOS - BREMSSCHEIBEN BELÜFTET - DISCHI FRENI VENTILATI - GEVENTILEERDE REMSCHIJVEN

CITROËN SAXO



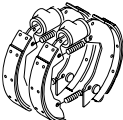

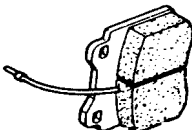



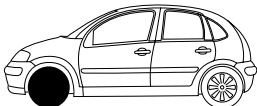
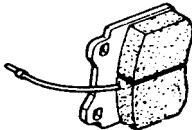

				
TT   BENDIX	4241 6A	4241 E7	• Gauche 4402 90	•• Droit 4402 91
Ess DI   BENDIX	4241 6C	<i>4241 J9</i> RP 4241 L3	4402 93	4402 94
TT  GIRLING	4241 4L → 07/01/99 4241 7E 08/01/99 →	4241 J5	4402 C3 RP 4402 A8 → 01/99 4402 C8 01/99 →	
  BENDIX	-	4241 J6	4402 92	
				
TT	95 666 971 RP 4252 57		 95 661 749 (Ø 247 E8)	

• **GAUCHE** : LEFT - IZQUIERDO - ESQUERDO - LINKS - SINISTRA - LINKS
 •• **DROIT** : RIGHT - DERECHO - DIREITO - RECHTS - DESTRA - RECHTS

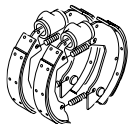
CITROËN C2

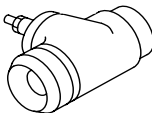

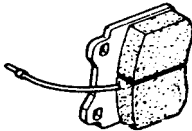







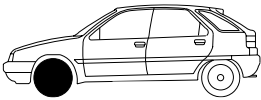
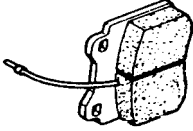
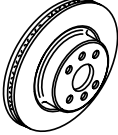
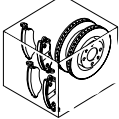
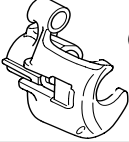

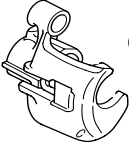
					
Ess 1,1 i L - 1,4 i L DI 1,4 L HDi		4252 58		 4246 R4 (Ø 266 E13)	
Ess 1,6 i L 16 V		4252 37		 4246 W1 (Ø 266 E22)	
					
Ess 1,1 i L - 1,4 i L Sans ABR DI 1,4 L HDi Sans ABR		4242 08		• Gauche •• Droit 4402 E9 (2) (ø 19)	
Ess 1,1 i L - 1,4 i L Avec ABR DI 1,4 L HDi Avec ABR		4242 02		4241 L0 4402 C8 (2) (ø 20,6)	
					
Ess 1,6 i L 16 V		4252 41		4246 X8 (Ø 247 E9)	

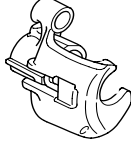

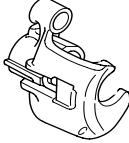

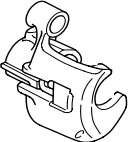

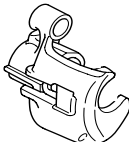
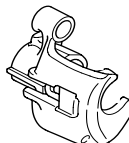

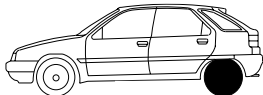
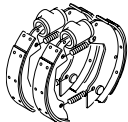

• GAUCHE : LEFT - IZQUIERDO - ESQUERDO - LINKS - SINISTRA - LINKS
 •• DROIT : RIGHT - DERECHO - DIREITO - RECHTS - DESTRA - RECHTS

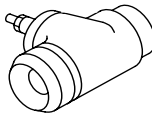
CITROËN C3		CITROËN C3 PLURIEL		
				
1,1 I L - 1,4 I L 1,4 L HDi	4252 36 RP 4252 58	 4246 R4 (Ø 266 E13)		
1,4 HDi 16 V 1,6 I L 16 V	4252 37	 4246 W1 (Ø 266 E22)		
				
1,1 I L - 1,4 I L Sans ABR 1,4 L HDi Sans ABR	4242 01	4241 L0	• Gauche	•• Droit
	4242 08		4402 E1 (Ø 19)	4402 E2 (Ø 19)
1,1 I L - 1,4 I L Avec ABR 1,4 L HDi Avec ABR	4242 02		4402 E9 (Ø 19) (2)	4402 E3 RP 4402 C8 (Ø 20,6)
				
1,4 HDi 16 V 1,6 I L 16 V	4252 41	4246 X8 (Ø 247 E9)		

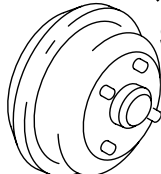
• GAUCHE : LEFT - IZQUIERDO - ESQUERDO - LINKS - SINISTRA - LINKS
 •• DROIT : RIGHT - DERECHO - DIREITO - RECHTS - DESTRA - RECHTS

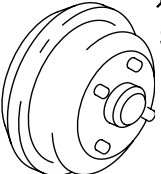

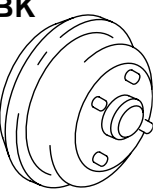
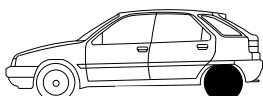
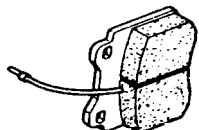







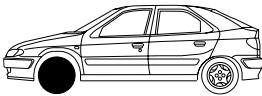
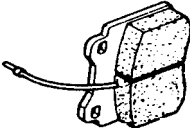

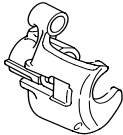

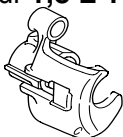

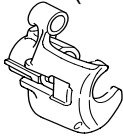

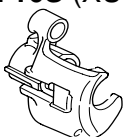
CITROËN ZX

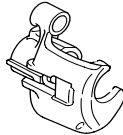
				
Ess	1,1 L - 1,4 L  GIRLING	95 666 970	 95 661 748 (Ø 247 E10)	4246 X2
	1,6 L - 1,8 L - 1,9 L 1,8 L 16S 2 L Sauf 16S  GIRLING	95 658 557	 95 661 747 (Ø 247 E20,4)	4246 X3
	(XU10J4) 2 L 16S  BENDIX	95 666 894	 4246 W6 (Ø 266 E20,4)	-
	(XU10J4RS) 2 L 16S  GIRLING	4251 44	 4246 V0 (Ø 283 E22)	
DI	BL 1,4 L - 1,5 L - 1,8 L 1,9 L Atmo  BENDIX	95 666 970	 95 661 748 (Ø 247 E10)	4246 X2
	BL 1,8 L - 1,9 L Atmo → 06/93  GIRLING	95 659 353		-
	Atmo BK Turbo BL - BK  GIRLING	95 658 557	 95 661 747 (Ø 247 E20,4)	4246 X3



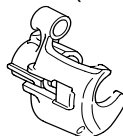

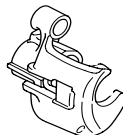



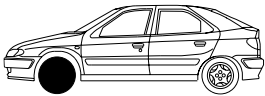
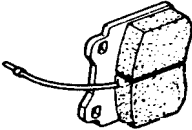

			CITROËN ZX	
				
BL   Sauf 1,8L 16S BENDIX	4241 5V → 7/92	95 659 470	• Gauche → 7/92 95 659 474 (Ø 20,6)	•• Droit → 7/92 95 659 475 (Ø 20,6)
	4241 5Y 7/92 →		7/92 → 4402 97 (Ø 20,6)	7/92 → 4402 98 (Ø 20,6)
BL   Sauf 1,8L 16S GIRLING	4241 4P → 7/92	95 659 676	→ 7/92 4402 86 (Ø 20,6)	→ 7/92 4402 87 (Ø 20,6)
	4241 4R 7/92 →		7/92 → 4402 A0 (Ø 20,6)	7/92 → 4402 A1 (Ø 20,6)
BL-BK   GIRLING	4241 4Z	4241 J1	4402 A8 (2) (Ø 20,6)	
BK  BENDIX	4241 6E	4241 K1	4402 A2 (2) (Ø 20,6)	
				
Ess 1,6 L - 1,8 L Sauf 1,8 L 16S Ess 1,9 L - 2 L - 2 L 16S Sauf XU10J4RS DI TURBO	95 666 971 RP 4252 57	 95 661 749 (Ø 247 E8)		
Ess 2 L 16S (XU10J4RS)	4251 97 RP 4252 74			

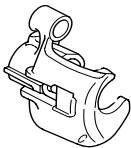
• **GAUCHE** : LEFT - IZQUIERDO - ESQUERDO - LINKS - SINISTRA - LINKS
•• **DROIT** : RIGHT - DERECHO - DIREITO - RECHTS - DESTRA - RECHTS

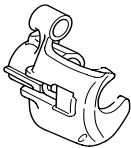
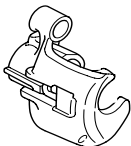



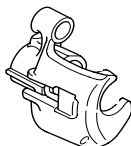

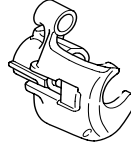



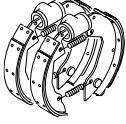

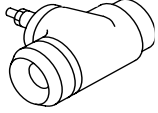
CITROËN XSARA → 27/08/2000

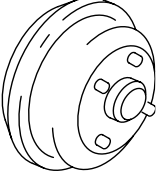
			
BL Ess	1,4 L   BOSCH	4252 05	 4246 R9 (Ø 247 E13)
	1,4 L  1,6 L - 1,8 L Sauf 1,8 L 16S  TEVES	4251 70	 95 661 747 (Ø 247 E20,4)
	1,8 L - 1,8 L 16S 2 L 16S (XU10J4R)  GIRLING	4251 55	 4246 W6 (Ø 266 E20,4)
	1,8 L - 1,8 L 16S 2 L 16S (XU10J4R)  BOSCH	4252 03	 4246 W6 (Ø 266 E20,4)
BK Ess	1,4 L - 1,6 L   TEVES	4251 70	 95 661 747 (Ø 247 E20,4)
	1,4 L - 1,6 L  1,8 L - 1,8 L 16S 2 L 16S (XU10J4R)  GIRLING	4251 55	 4246 W6 (Ø 266 E20,4)
	1,4 L - 1,6 L 1,8 L - 1,8 L 16S 2 L 16S (XU10J4R)  BOSCH	4252 03	 4246 W6 (Ø 266 E20,4)
BL - BK Ess	2 L 16S (XU10J4RS)  GIRLING	4251 44	 4246 T9 (Ø 283 E22)

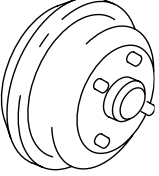
CITROËN XSARA → 27/08/2000

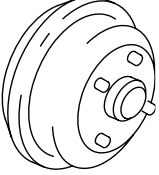
			
BL DI	1,5 L   BOSCH	4252 05	 4246 R9 (Ø 247 E13)
	1,5 L   TEVES		
	1,8 L - 1,9 L DI Atmo 1,9 L DI Turbo  TEVES		
BL DI	2 L DI Turbo   GIRLING	4251 55	 4246 W6 (Ø 266 E20,4)
BL - BK DI	1,5 L - 1,8 L 1,9 L DI Atmo 1,9 L DI Turbo 2 L DI Turbo  BOSCH	4252 03	 4246 W6 (Ø 266 E20,4)
BK DI	1,5 L - 1,8 L 1,9 L DI Atmo   TEVES	4251 70	 95 661 747 (Ø 247 E20,4)
	1,5 L - 1,8 L 1,9 L DI Atmo  1,9 L DI Turbo 2 L DI Turbo  GIRLING		

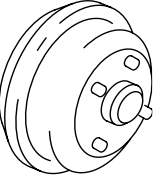
CITROËN XSARA → 27/08/2000

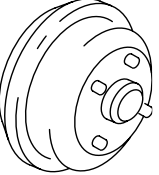
				
<p>BL </p>  <p>BOSCH</p>	<p>4241 6F RP 4242 06</p>	<p>4241 G3 RP 4241 L4</p>	<p>• Gauche</p> <p>4402 97 (Ø 20,6)</p>	<p>•• Droit</p> <p>4402 98 (Ø 20,6)</p>
<p>BL </p> <p>Sauf DI Turbo</p>  <p>GIRLING</p>	<p>4241 4Y</p>	<p>4241 E5</p>	<p>4402 A0 (Ø 20,6)</p>	<p>4402 A1 (Ø 20,6)</p>
<p>BL DI Turbo TT</p> <p>BL </p>  <p>GIRLING</p>	<p>4241 4Z</p>	<p>4241 J1</p>	<p>4402 A8 (Ø 20,6)</p>	
<p>BK </p> <p>Sauf DI Turbo</p>  <p>BOSCH</p>	<p>4241 6G</p>	<p>4241 K3</p>	<p>4402 A2 (Ø 20,6)</p>	
<p>BK DI Turbo TT</p> <p>BK </p>  <p>BOSCH</p>	<p>4241 6H</p>	<p>4241 K3</p>	<p>4402 C7 (Ø 22)</p>	

• GAUCHE : LEFT - IZQUIERDO - ESQUERDO - LINKS - SINISTRA - LINKS
 •• DROIT : RIGHT - DERECHO - DIREITO - RECHTS - DESTRA - RECHTS

CITROËN XSARA → 27/08/2000

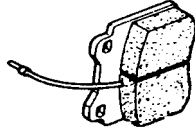
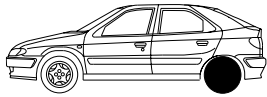

BL

4251 97
RP 4252 74

95 661 749
(Ø 247 E8)

BK











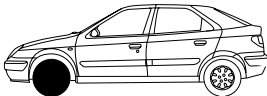
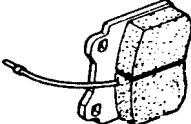

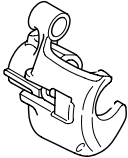

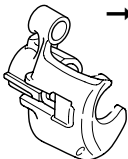
95 666 971
RP 4252 57

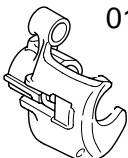

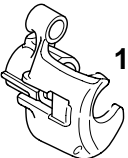

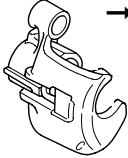

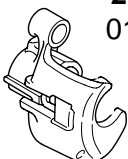
--	--	--

--

CITROËN XSARA 28/08/2000 →

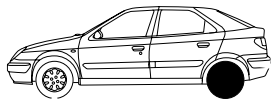
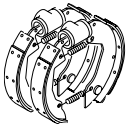

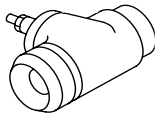
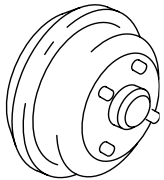
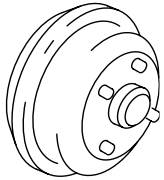
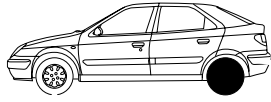
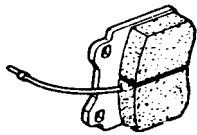

			
ESS	<p>1,4 L - 1,6 L 16 S</p>  <p>BOSCH</p>	<p>4252 18</p>	 <p>4246 W1 (Ø 266 E22)</p>
	<p>2 L 16 S → 12/2001</p>  <p>GIRLING</p>	<p>4251 44</p>	 <p>4246 T9 (Ø 283 E22)</p>
	<p>2 L 16 S 01/2002 →</p>  <p>BOSCH</p>	<p>4252 35</p>	 <p>4246 W2 (Ø 283 E26)</p>
DI	<p>1,9 L Atmo 2 L Turbo</p>  <p>1,4 L HDi</p> <p>BOSCH</p>	<p>4252 18</p> <p>4252 40</p>	 <p>4246 W1 (Ø 266 E22)</p>
	<p>2 L Turbo → 12/2001</p>  <p>GIRLING</p>	<p>4251 44</p>	 <p>4246 T9 (Ø 283 E22)</p>
	<p>2 L Turbo 01/2002 →</p>  <p>BOSCH</p>	<p>4252 35</p>	 <p>4246 W2 (Ø 283 E26)</p>

CITROËN XSARA 28/08/2000 →

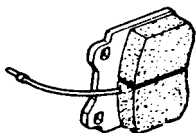
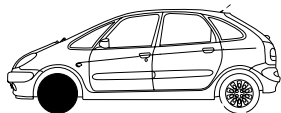

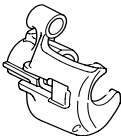

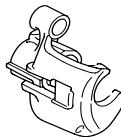
			
BL Ess 1,4 L DI 1,9 L Atmo  GIRLING	4241 4Z → 10/2000	4241 J1	• Gauche •• Droit 4402 A8 → 10/2000 (Ø 20,6)
	4241 9H 10/2000 →		4402 C8 10/2000 → (Ø 20,6)
BK Ess 1,4 L DI 1,9 L Atmo  BOSCH	4241 6H	4241 K3	4402 C7 (Ø 22)
			
BL - BK Sauf 2 L 16 S (XU10J4RS)	95 666 971 RP 4252 57	 95 661 749 (Ø 247 E8)	
BL - BK 2 L 16 S (XU10J4RS)	4251 97 RP 4252 74		
<ul style="list-style-type: none"> • GAUCHE : LEFT - IZQUIERDO - ESQUERDO - LINKS - SINISTRA - LINKS •• DROIT : RIGHT - DERECHO - DIREITO - RECHTS - DESTRA - RECHTS 			

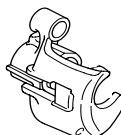
CITROËN XSARA PICASSO



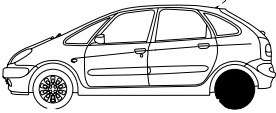
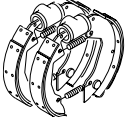
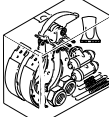

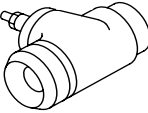
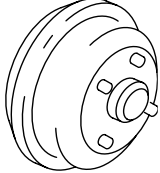
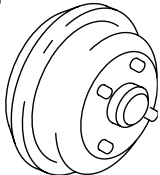
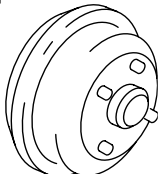
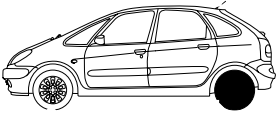
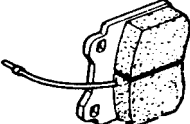



TT	 <p>LUCAS → 11/2001</p>	4252 13	 <p>4246 W6 (Ø 266 E20,4)</p>
	<p>11/2001 →</p>	4252 34	
	 <p>BOSCH 11/2001 → SANS ESP</p>	4252 40	 <p>4246 W1 (Ø 266 E22)</p>
	 <p>BOSCH 11/2002 → AVEC ESP</p>	4252 53	<p>4246 W2 (Ø 283 E26)</p>

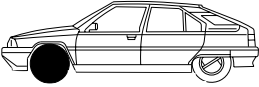
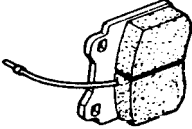

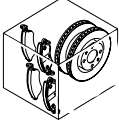

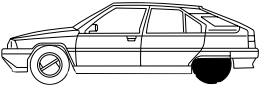
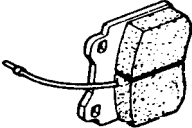

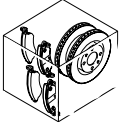



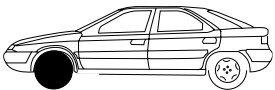
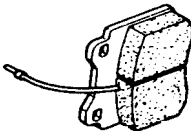

CITROËN XSARA PICASSO

				
TT  BENDIX	4241 7A	-	4241 K8	4402 C6 (Ø 22,2)
TT  LUCAS SANS ESP → 02/03 AVEC ABR 02/03 →				
TT  LUCAS SANS ESP AVEC ABR 02/03 →	4241 7A	-	4241 L6	4402 E8 RP 4402 C6 (Ø 22,2)
				
TT LUCAS AVEC ESP 11/02 →	4252 41		 4246 X8 (Ø 247 E9)	





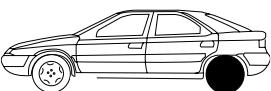
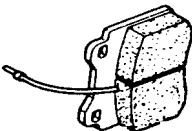

CITROËN BX

CITROËN BX			
			
TT Sauf GTI 16S	95 624 484	 95 661 746 (Ø 266 E10)	4246 X4
GTI 16S		 4246 W6 (Ø 266 E20,4)	-
			
TT	95 650 890	95 661 849 (Ø 224 E7)	4246 X5

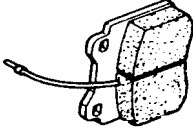



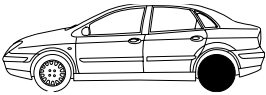
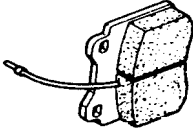

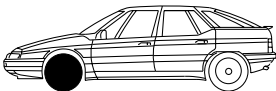
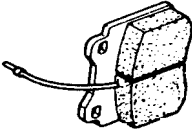

CITROËN XANTIA

		
BL 1,6 L 1,8 L 1,8 L 16S 2 L → 12/97 1,9 L DI Atmo 1,9 L DI Turbo Sauf Depol CEE 95 → 07/97 1,9 L DI Turbo Depol CEE 95 07/97 → 2 L DI Turbo	4251 56	 4246 W6 (Ø 266 E20,4)
BK 1,8 L - 1,8 L 16S  1,8 L - 1,8 L 16S  05/97 →		
BK 1,8 L (XU7JP)  → 05/97 BL-BK 2 L BL 2 L 16S (XU10J4)  BL-BK 2 L 16S (XU10J4R)  BK 1,9 L DI ATmo BK 1,9 L DI Turbo BL 1,9 L DI Turbo Depol CEE 95 → 07/97 BK 2 L DI Turbo (DW10TD)	4251 57	 4246 V0 (Ø 283 E22)
BL 2 L 16S (XU10J4R)  → 10/98 BL-BK 2 L Ess Turbo Ech → 10/98 BL-BK 2,1 L DI Turbo → 10/98		4251 58
BL 2 L 16S (XU10J4R)  10/98 → BL-BK 2 L Ess Turbo Ech 10/98 → BL-BK V6 3 L BL-BK 1,9 L DI Turbo (XUD9TE) BVA BL-BK 2 L DI Turbo (DW10ATED) BL-BK 2,1 L DI Turbo 10/98 →	4251 45 Sauf AUS, J	
	4252 11 AUS, J	
		
BL	95 667 788	 95 667 811 (Ø 224 E9)
BK	4251 29	4246 L6 (Ø 251 E12)



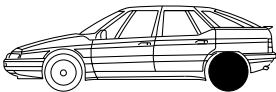
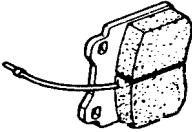

CITROËN C5

		
BL 1,8 L 16 S	4252 14 RP 4252 87	 4246 W1 (Ø 266 E22)
BK 1,8 L 16 S BL-BK 2 L BL-BK 2 L 16 S BL-BK 2 L DI Turbo BL-BK 2 L HDi	4252 15 RP 4252 88 → 04/2003 4252 88 04/2003 →	 4246 W2 (Ø 283 E26)
BL-BK V6 3L BL-BK 2,2 L 16 S DI Turbo BL-BK 2 L HDi	4252 16 RP 4252 89 → 04/2003 4252 89 04/2003 →	 4246 W3 (Ø 288 E28)
		
BL-BK	4252 17 RP 4252 90	 4246 W4 (Ø 276 E14)



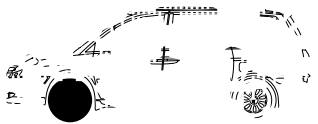
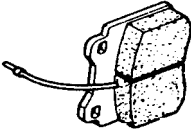

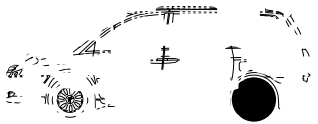
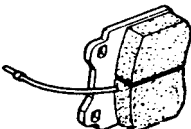



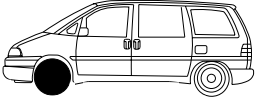
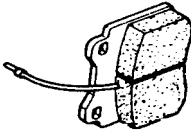

CITROËN XM

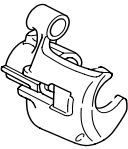
		CITROËN XM	
			
TT Sauf V6 3L (ES9J4) 2,5 L DI Turbo → 04/97	95 666 972 → 03/91		95 661 812 → 03/91 (Ø 276 E22)
	95 659 640 03/91 →		95 661 813 03/91 → (Ø 283 E26)
V6 3 L (ES9J4) 2,5 L DI Turbo 04/97 →	4252 11		4246 T2 (Ø 288 E28)
			
BL Sauf V6 3L (ES9J4) 2,5 L DI Turbo → 04/97	95 667 788		95 661 814 (Ø 224 E9)
BL V6 3 L (ES9J4) 2,5 L DI Turbo 04/97 →	4251 83		4246 T3 (Ø 232 E9)
BK	95 661 798		95 661 796 (Ø 251 E12)

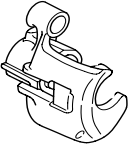

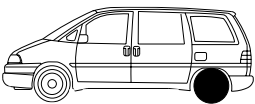
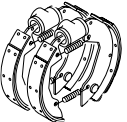

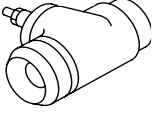
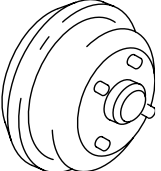
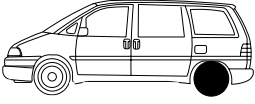
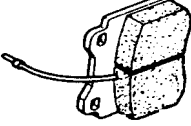
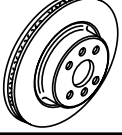
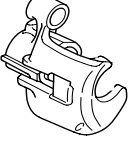

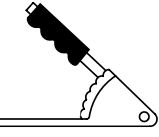
CITROËN C8



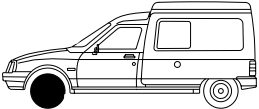
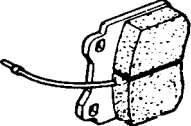

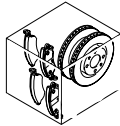

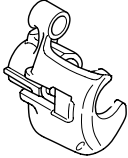
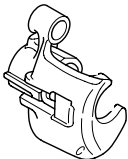
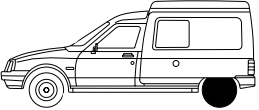
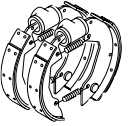

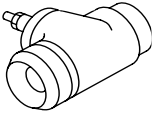

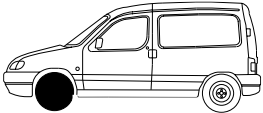
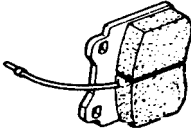

CITROËN C8		
		
TT 2 L 16S (EW10J4) 2,2 L 16S (EW12J4) 2L HDi (DW10) 2,2 L HDi (DW12 TED4)	4252 31	 4246 P2 (Ø 285 E28)
3 L V6 (ES9J4S)	4252 55	4246 Z8 (Ø 310 E32)
		
TT	4252 33	 4246 W4 (Ø 272 E12)

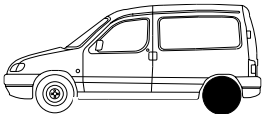
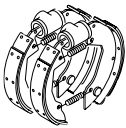
CITROËN EVASION

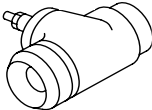
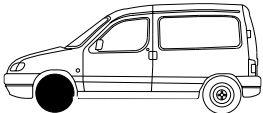
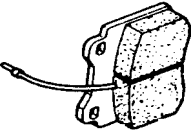
							
TT  BENDIX		4251 50		 4246 H9 (Ø 257 E20)			
TT Sauf Injection XU7JP  GIRLING		4251 10		 4246 J3 (Ø 281 E26)			
							
TT  BENDIX		4241 6J		4241 K6		4402 A7 (Ø 19)	
							
TT  TEVES		4251 12		 4246 J6 (Ø 295 E10)			
		4241 G7					



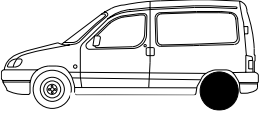
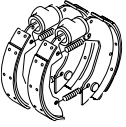





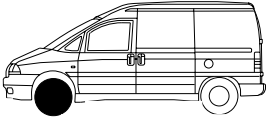
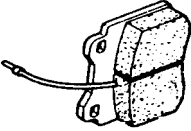

CITROËN C15

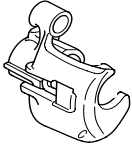
				
Ess	1 L 1,1 L 1,4 L	95 648 537 → 09/87	 75 485 825 (Ø 244,5 E9)	—
	1,118 L 1,294 L	95 647 733 05/88 →		4246 X6
	 GIRLING	95 647 733		
DI	 BOSCH	95 666 970	95 661 748 (Ø 247 E10)	
				
TT	4241 5T	95 625 020	00 17 689 400 (2)	

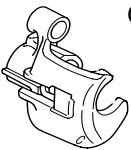
			CITROËN BERLINGO (VP-VU)	
				
• Disques non ventilés	4251 55		4246 R4 (Ø 266 E13)	
•• Disques ventilés	4251 55 → 11/2001 4252 40 11/2001 →		4246 W6 (Ø 266 E20,4)	
				
TT	4241 7A	4241 K8	4402 C6 (2) (Ø 22,2)	
			CITROËN BERLINGO 2 (VP-VU)	
				
TT  Sans ESP BOSCH	4252 40		4246 W1 (Ø 266E 22)	
				
TT	4241 7A	4241 K8 → 02/2003	4402 C6 (2) (Ø 22,2)	
		4241 L6 02/2003 →	4402 E8 RP 4402 C6 (2) (Ø 22,2)	

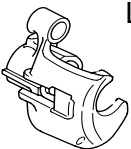

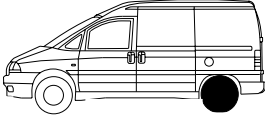
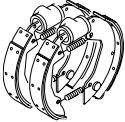

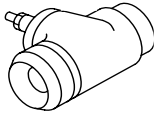

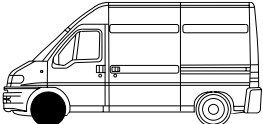
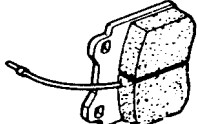

(VP) VEHICULE PARTICULIER : CAR - VEHICULO PARTICULAR - VEÍCULO PARTICULAR - SPEZIALFAHRZEUG - VEICOLO PARTICOLARE - PERSONENWAGEN
(VU) VEHICULE UTILITAIRE : VAN - VEHICULO UTILITARIO - VEÍCULO UTILITÁRIO - NUTZFAHRZEUG - VEICOLO COMMERCIALE, INDUSTRIALE - BEDRIJFSWAGEN
• **DISQUES NON VENTILES** : NON VENTILATED BRAKE DISC - DISCOS DE FRENO NO VENTILADO - DISCOS NÃO VENTILADOS - BREMSSCHEIBEN NICHT BELÜFTET - DISCHI FRENI NON VENTILATI - NIET GEVENTILEERDE REMSCHIJVEN
•• **DISQUES VENTILES** : VENTILATED BRAKE DISC - DISCOS DE FRENO VENTILADO - DISCOS VENTILADOS - BREMSSCHEIBEN BELÜFTET - DISCHI FRENI VENTILATI - GEVENTILEERDE REMSCHIJVEN

CITROËN JUMPY

	CU*			
TT → 12/01 1,9 L DI (DW8B) 12/01 →  BENDIX	815 kg	4251 50		 4246 H9 (Ø 257 E20)
2,0 L 16S (EW10J4) 03/99 →  GIRLING	815 kg	4251 10		 4246 J3 (Ø 281 E26)
TT	900 kg	4251 10		 4246 J3 (Ø 281 E26)
Ess 2 L 16S DI 2L HDi 08/2003 →  LUCAS		4252 31		 4246 P2 (Ø 285 E28)
				
TT	4241 6J	4241 K6	4402 A7 (Ø 19)	



* CU - CHARGE UTILE : ADVISED WEIGHT - CARGA UTIL - CARGA ÚTIL - NUTZLAST - PORTATA UTILE - LAADVERMOGEN



CITROËN JUMPER → 02/2002

	CU*		
• Disques non ventilés GIRLING	1000kg	4251 17 (Connecteur rond) 4252 26 (Connecteur carré) → S 16206253	 4246 J9 (Ø 280 E18)
	1400kg	4251 19 (Connecteur rond) 4252 27 (Connecteur carré) → S 16206253	 4246 L4 RP 4246 Y1 (Ø 280 E24)
•• Disques ventilés BREMBO	1000kg 1400kg	4252 43 → S 16206253	 4246 K3 RP 4246 Y3 (Ø 300 E24)
GIRLING	1000kg 1400kg	4251 17 (Connecteur rond) 4252 26 (Connecteur carré) → S 16206253	 4246 Y1 (Ø 280 E24)
	1800kg	4251 19 (Connecteur rond) 4252 27 (Connecteur carré) → S 16205352	 4246 K3 RP 4246 Y3 (Ø 300 E24)
BREMBO	1800kg	4252 45 S 16194400 →	 4246 K3 RP 4246 Y3 (Ø 300 E24)

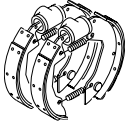

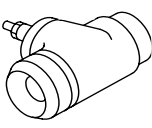

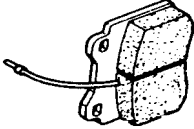

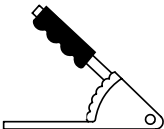



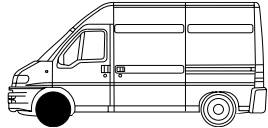
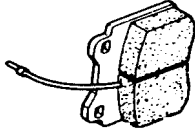

- **DISQUES NON VENTILES** : NON VENTILATED BRAKE DISC - DISCOS DE FRENO NO VENTILADO - DISCOS NÃO VENTILADOS - BREMSSCHEIBEN NICHT BELÜFTET - DISCHI FRENI NON VENTILATI - NIET GEVENTILEERDE REMSCHIJVEN
- **DISQUES VENTILES** : VENTILATED BRAKE DISC - DISCOS DE FRENO VENTILADO - DISCOS VENTILADOS - BREMSSCHEIBEN BELÜFTET - DISCHI FRENI VENTILATI - GEVENTILEERDE REMSCHIJVEN
- * **CU - CHARGE UTILE** : ADVISED WEIGHT - CARGA UTIL - CARGA ÚTIL - NUTZLAST - PORTATA UTILE - LAADVERMOGEN
- CONNECTEUR ROND** : WASHER CONNECTOR - CONECTOR REDONDO - LIGAÇÃO REDONDA - STECKER RUND - CONNETTORE ROTONDO - RONDE STEKKER
- CONNECTEUR CARRÉ** : SQUARE CONNECTOR - CONECTOR CUADRADO - LIGAÇÃO QUADRADA - STECKER RECHTECKIG - CONNETTORE QUADRATO - VIERKANTE STEKKER

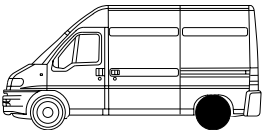
CITROËN JUMPER → 02/2002

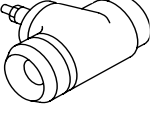
	CU*			
GIRLING	1000kg	4241 4V	4241 H4	4402 A3 (Ø 27)
	1400kg	4241 4W		4402 A4 (Ø 25,4)
LOOKEED S 16204256 →	1000kg 1400kg	—	4241 L2	4402 E4
GIRLING → S 16205352	1800kg	4241 4X	4241 H5	4402 A5 (Ø 28,6)

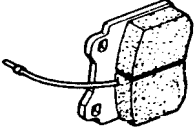

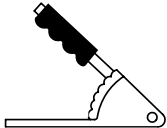



	CU*		
BREMBO → S 16194400	1000kg 1400kg	4252 47	4246 Y7 (Ø 280 E16)
	1800kg		4246 Z1 (Ø 280 E16)
Uniquement Frein à disque Arrière 			4241 L1

CITROËN JUMPER 02/2002 →

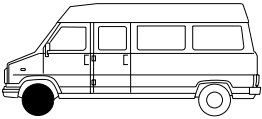
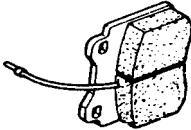

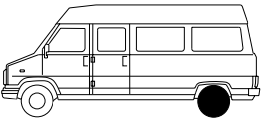
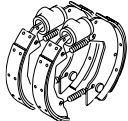

	CU*		
•• Disques ventilés BREMBO	1000kg 1400kg	4252 43	 4246 Y1 (Ø 280 E24)
	1800kg	4252 45	 4246 Y3 (Ø 300 E24)
	CU*		
LOOKEED	800kg 1000kg 1400kg	4241 L2	4402 E4 (2)
	* CU		
BREMBO	800kg 1000kg 1400kg	4252 47	4246 Y7 (Ø 280 E16)
	1800kg		4246 Z1 (Ø 280 E16)
Uniquement Frein à disque Arrière 		 4241 L1	

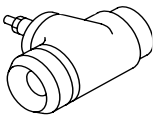
- **DISQUES VENTILÉS** : VENTILATED BRAKE DISC - DISCOS DE FRENO VENTILADO - DISCOS VENTILADOS - BREMSSCHEIBEN BELÜFTET - DISCHI FRENI VENTILATI - GEVENTILEERDE REMSCHIJVEN
- * **CU - CHARGE UTILE** : ADVISED WEIGHT - CARGA UTIL - CARGA ÚTIL - NUTZLAST - PORTATA UTILE - LAADVERMOGEN
- CONNECTEUR ROND** : WASHER CONNECTOR - CONECTOR REDONDO - LIGAÇÃO REDONDA - STECKER RUND - CONNETTORE ROTONDO - RONDE STEKKER
- CONNECTEUR CARRÉ** : SQUARE CONNECTOR - CONECTOR CUADRADO - LIGAÇÃO QUADRADA - STECKER RECHTECKIG - CONNETTORE QUADRATO - VIERKANTE STEKKER



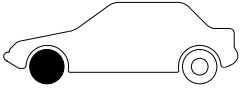
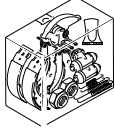
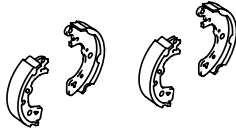
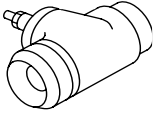
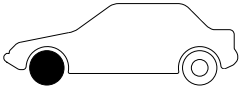
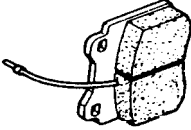

CITROËN C25



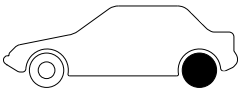
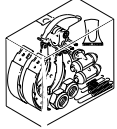

CITROËN C25			
			
Sauf 1800 kg Sauf DI Turbo	95 667 764		4246 N3 → 155 247 (04/84)
			4246 N5 155 248 → (04/84)
1800 kg DI Turbo	95 667 765		4246 N7
			
800 kg	4241 4T 73501→	4241 H8	4402 85
1000 kg 1300 kg 1400 kg			4402 58 → 73500 4402 70 73501→
1800 kg	—	4241 H9	4402 81

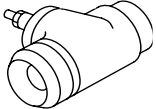
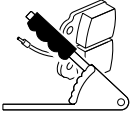
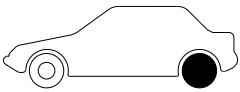
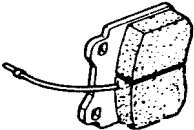
2 CV - DYANE - MEHARI - AMI - ACADIANE

			
2 CV et DYANE → 6/70	◀ M		
AMI 8 → 9/69 MEHARI → 1/72	-	NFP	75 530 008 S NFP
2 CV 4 6/70 → 2 CV 6 6/70 → 6/81 DYANE 4 6/70 → 7/75	4241 3E	4241 G4	75 492 434 S
DYANE 6 (AYB) 6/70 → 7/77 MEHARI 1/72 → 7/77	NFP	NFP	
			
2 CV 6 6/81 → DYANE 6 (AYB) 7/77 → MEHARI 7/77 → AMI 8 9/69 → ACADIANE 2/78 →	95 653 061		95 599 322
AMI SUPER	NFP		95 535 891 NFP

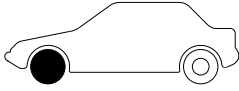
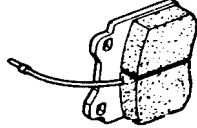
2 CV - DYANE - MEHARI - AMI - ACADIANE

				
MEHARI → 1/72 AMI 8 BL → 9/69	-	95 663 080 NFP	AM 453 05 A NFP	S
2 CV 4 6/70 → 2 CV 6 6/70 → 6/81 DYANE 4 6/70 → 7/75 DYANE 6 (AYB) 6/70 → 7/77 MEHARI 1/72 → 7/77	95 666 838 NFP	95 663 080 NFP	5 488 527	S
DYANE 6 (AYB) 7/77 → 7/78 MEHARI 7/77 → 7/78	-	95 663 080 NFP	NFP	4251 59
2 CV 6 6/81 → DYANE 6 (AYB) 7/78 → MEHARI 7/78 → AMI 8 BL 9/69 →	95 666 840 NFP	95 663 080 NFP	AMN 453 05	M
ACADIANE 2/78 → 7/78 ACADIANE 7/78 → 10/79 AMI 8 BK	-	95 663 080 NFP	NFP AMN 453 032 NFP	M M
ACADIANE 10/79 →	95 666 839 NFP	95 663 080 NFP	5 411 942	M
AMI SUPER				95 663 072 NFP
				
MEHARI 4 x 4	NFP		NFP	

		LN - LNA	
			
LN LNA → 10/81	95 663 076	 95 669 224	
LNA 10/81 →	95 648 537	 75 485 825	

LN - LNA

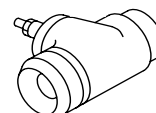
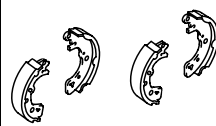
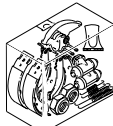
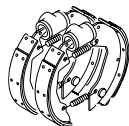
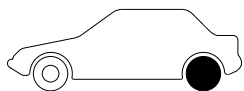

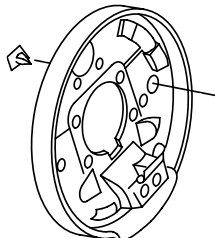

DBA :

Carré visible
sur le flasque

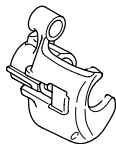



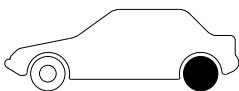
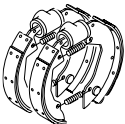
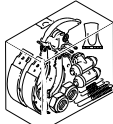
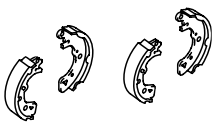
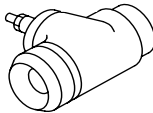
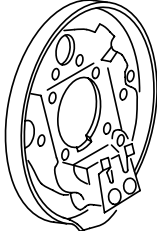

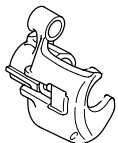

LN	→ 10/77	-	-	NFP	• Gauche	•• Droit
					NFP	NFP
LN	10/77→	4241 5P	95 644 434 RP 4241 5P	4241 99 NFP	4402 50 (Ø 22,2)	
LNA LNA CLUB	 DBA					
LNA	Citroën	4241 5R	95 644 435 RP 4241 5R		95 569 738 (Ø 20,6)	



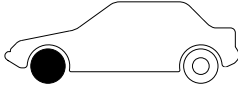
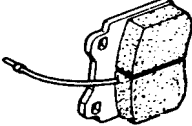
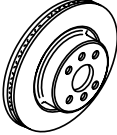
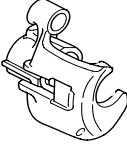

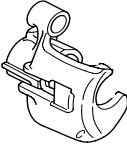

• **GAUCHE** : LEFT - IZQUIERDO - ESQUERDO - LINKS - SINISTRA - LINKS
 •• **DROIT** : RIGHT - DERECHO - DIREITO - RECHTS - DESTRA - RECHTS

				LN - LNA	
					
GIRLING : Pas de carré sur le flasque 					
LN → 10/77	-	-	NFP	• Gauche	•• Droit
				NFP	NFP
LN 10/77→ 	-	95 618 239	4241 93 NFP	4402 49 (Ø 22,2)	
LNA DBA	-	95 618 241		95 534 127 (Ø 20,6)	
	-	95 618 241			
LNA Citroën					

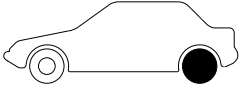
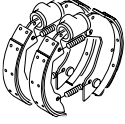
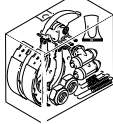

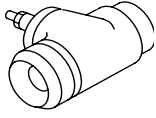
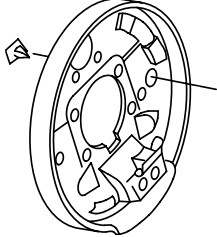

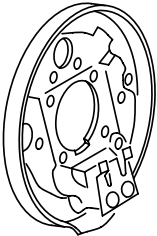
• **GAUCHE** : LEFT - IZQUIERDO - ESQUERDO - LINKS - SINISTRA - LINKS
 •• **DROIT** : RIGHT - DERECHO - DIREITO - RECHTS - DESTRA - RECHTS



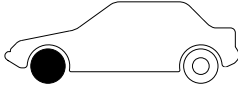
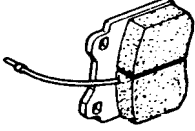

VISA

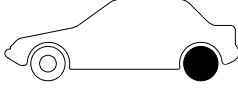
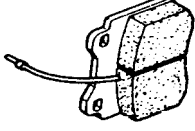
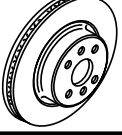
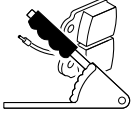
VISA		
		
<p>78 → 04/81</p> <p>Sauf GT - Chrono - GTI - DI</p>  <p>BENDIX</p>	<p>95 663 076</p>	 <p>95 669 224</p>
<p>78 →</p> <p>Sauf GT - Chrono - GTI - DI</p>  <p>CITROËN</p>	<p>95 648 537</p>	 <p>75 485 825</p>
<p>GT CHRONO</p>	<p>95 663 077 NFP</p>	 <p>95 669 224</p>
<p>GTI</p>	<p>95 647 733</p>	 <p>NFP</p>
<p>DI</p>		 <p>95 661 748</p>



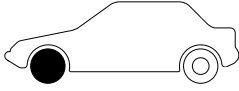
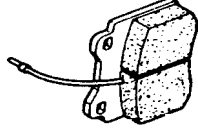
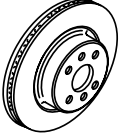

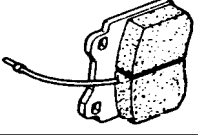
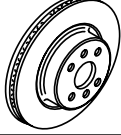
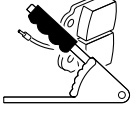

			VISA	
				
DBA :				
<p>Carré visible sur le flasque</p> 				
	4241 5R	95 644 435 RP 4241 5R	4241 99 NFP	95 569 738 (Ø 20,6)
 Sauf GTI - Sauf DI	4241 5P	95 644 434 RP 4241 5P		4402 50 (Ø 22,2)
GTI DI	4241 5N	95 618 243 RP 4241 5N	95 609 802 NFP	95 496 738 (Ø 22,2) NFP
GIRLING :				
<p>Pas de carré sur le flasque</p> 				
	95 618 241	4241 93 NFP	95 534 127 (Ø 20,6)	
	95 618 239		4402 49 (Ø 22,2)	

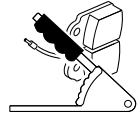
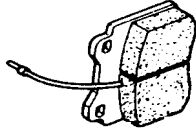
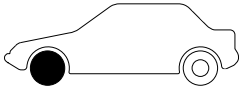
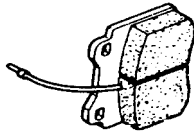
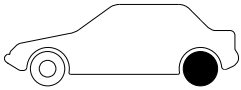
AXEL

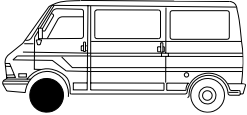
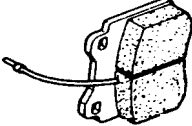
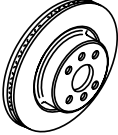

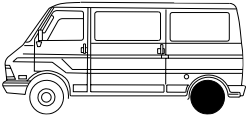
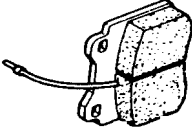

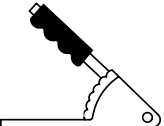



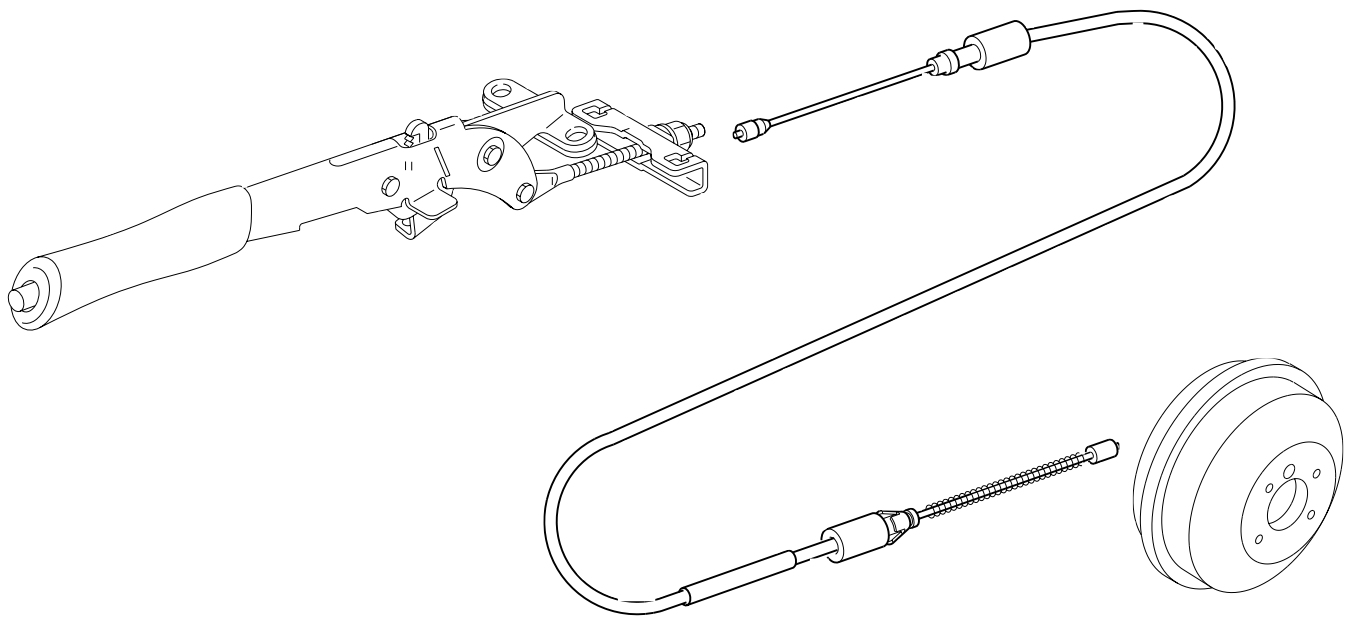

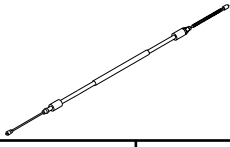
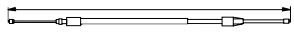
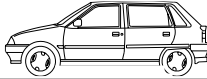

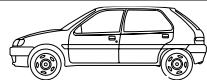

							
TT		4251 87 NFP		 95 551 384 NFP			
							
TT		4251 86 NFP		 95 543 736 NFP		95 663 072 NFP	





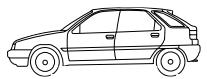

		GS - GSA	
			
GS → 2/73	NFP	NFP	
GS 2/73 → GSA → 6/80	NFP	 95 535 891 NFP	
GSA 6/80 →	95 650 995		
			
GS → 11/72	NFP	NFP	4251 59 → 2/73
GS 11/72 → GSA	95 650 996	 5 448 826 NFP	NFP 2/73 → 9/79 95 663 072 9/79 → NFP



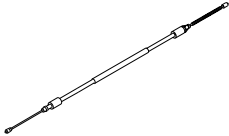
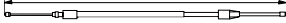

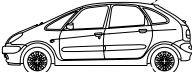

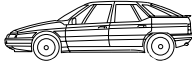

CX**BL - BK****95 624 480****75 529 364****95 624 483****BL****95 650 872
NFP****95 661 850****BK → 6/80****NFP****5 462 434****BK 6/80 →****95 624 482**

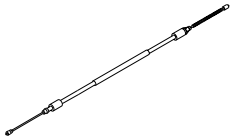
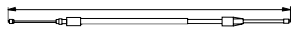
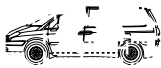



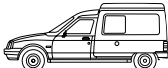



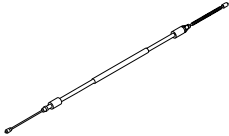
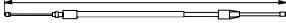
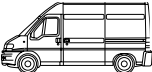

		C35	
			
TT	4251 61		5 416 277 (Ø 285 E20)
			
TT	4251 62		5 426 184
	4251 63		95 577 360

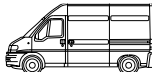

			
		G	D
	AX		
TT - Sauf  Sauf 4 x 4		95 604 194	1431
4 x 4		96 044 362	1418
		4745 H6	1395
	SAXO		
Sauf  		4745 T4	1445
Sauf  		4745 H8	1509
		4745 J1	1121
C2			
TT 		4745 W3	–
TT 		4745 W4	–
	C3 - C3 PLURIEL		
TT		4745 V0	–
TT		4745 V1	–
	ZX		
BL → 12/96		4745 F8	–
		–	4745 G1
BL 12/96 →		4745 K4	–
		–	4745 K5
BK → 12/96		4745 E8 (2) 	
BK 12/96 →		4745 K8	–
		–	4745 K9
BL-BK → 12/96		4745 F6	–
		–	4745 F9
BL-BK 12/96 →		4745 K6	–
		–	4745 K7

			
	G	D	
	XSARA		
BL	4745 J8	–	1275
	–	4745 J9	1185
BK	4745 K2	–	1260
	–	4745 K3	1170
BL - BK	4745 K0	–	1260
	–	4745 K1	1277
	XSARA PICASSO		
Tous Types	4745 P5	–	1775
	–	4745 P6	1865
Tous Types 11/2002 →	4745 W0	–	1855
	–	4745 W1	1945
	BX		
BL - BK	4745 L2		1642
	XANTIA		
Tous Types	4745 G5 Sauf BVM ML	–	1265
Sauf V6	4745 H5 BVM ML	–	1295
	–	4745 G6	1335
V6	4745 H5 Sauf BVA AL4	–	1295
	4745 N3 BVA AL4	–	1285
	–	CAG 4745 J4	1365
	–	CAD 4745 J5	1335
	C5		
Tous Types	4745 R5 (2) 		1838
	XM		
Tous Types Sauf V6 24S	96 026 875	–	1030
	–	96 026 873	1230
V6 24S	96 092 761	–	1030
	–	96 068 340 CAG	1390
	–	96 026 873 CAD	1230

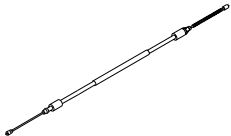
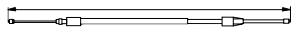

				
	G	D		
	C8			
Tous Types	4745 T6 CAG	4745 T8 CAG	–	
	4745 T7 CAD	4745 T6 CAD	–	
	EVASION			
Tous Types		4745 F2	–	1065
		–	4745 F3 CAG	2235
		–	4745 G8 CAD	2365
Tous Types		4745 F4 CAG	–	1255
		–	4745 F5 CAG	2200
		4745 R3 CAD	–	–
		–	4745 R4 CAD	–
	C15			
Sauf Plancher Cabine Sauf Familiale	4745 N6 + 4853 15		1713	
Plancher Cabine Familiale	4745 N7 + 4853 15		1705	
	BERLINGO			
Sauf 	4745 J0	–	1747	
	–	4745 J3 → 11/99	1821	
	–	4745 R0 11/99 →	1881	
	4745 N1		1300	
	JUMPY			
Tous Types		4745 F2	–	1065
		–	4745 F3 CAG	2235
		–	4745 G8 CAD	2365

			
	G	D	
	JUMPER → 02/2002		
(Suspension Normale) Sauf Camping Car Sauf 4 x 4		4745 G3 → S 16158427 4745 V2 S 16158428 → S 16194399 4745 V5 S 16194400 →	3047
(Suspension AR Renforcée) Camping Car Sauf 4 x 4		4745 G7 → S 16158427 4745 V2 S 16158428 → S 16194399	3047
4 x 4 Sauf BV5 MLGU		4745 J2	
4 x 4 BV5 MLGU		4745 V2 Sauf châssis long 4745 J2 Châssis long	
4 x 4 BV5 MLGU		4745 W8 RP 4745 V5 Châssis court - Simple lame 4745 W9 RP 4745 G3 Châssis court - Double lame 4745 X0 RP 4745 G3 Châssis moyen - Simple lame 4745 X1 RP 4745 G7 Châssis moyen - Double lame 4745 J2 Châssis long	
S 16194400 →		4745 V4	
	JUMPER 02/2002 →		
TT Sauf 4 x 4		4745 V5	
		4745 V4 → S 17103012 4745 W5 S 17103013 →	
Bicarburant Essence		4745 W7 CAG	

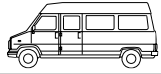
			
	G	D	



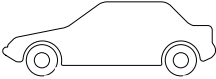
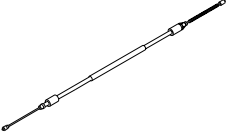
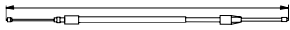



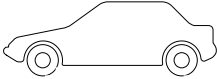
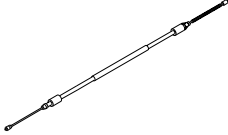
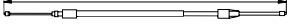

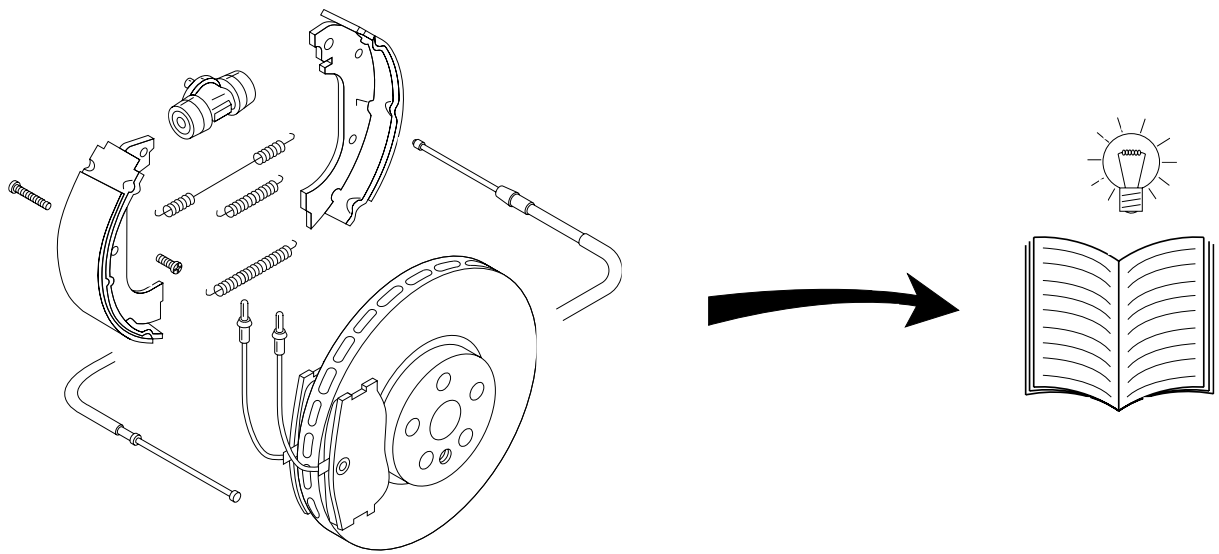

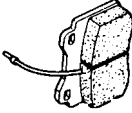
**C25**

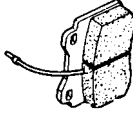







Sauf 4 x 4 - Sauf XT 800 kg	4834 76	2566
4 x 4	4745 96	2600
XT 800 kg	4745 80	2255
C25 BVM4 → 08/80	<i>5 455 064</i> NFP	923
C25 BVM4 09/80 →	<i>75 492 188</i> NFP	935
C25 BVM5 4 x 2	95 639 111	1067

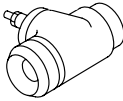

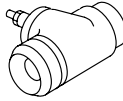

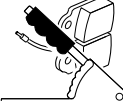
			
	G	D	
2CV - AZU - AKS - DYANE - MEHARI - AMI8 - AMI SUPER - ACADIANE - LN-LNA			
2CV - AZU - AKS Dyane → 07/77 Mehari → 07/77	AZ 454 1F NFP		406
Dyane 07/77 → Mehari 07/77 →	75 491 847 → 03/78 NFP	–	708
	75 492 021 03/78 →	–	653
	–	75 491 848 1 Pos	528
	–	95 493 494 2 Pos NFP	390
Ami 8 → 09/69	AK 454 1A NFP		419
Ami 8 09/69 → 03/72	AM 454 1B (2) NFP 		380-415
Ami 8 03/72 →	5 429 787 NFP	–	380
	–	5 429 788 NFP	515
Ami Super	5 426 164 NFP	–	370
	–	5 426 165 NFP	582
Acadiane	75 492 021	–	653
	–	75 491 848 1 Pos	528
	–	95 493 494 2 Pos NFP	390
LN LNA → 07/82	79 10 015 915 NFP DBA		1271
LNA 07/82 →	95 495 615		1266

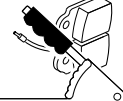
				
	G	D		
VISA - AXEL - GS-GSA				
Visa	4745 41		770	
Axel	95 493 395 NFP		1219	
GS GSA	CAG	75 510 162 NFP	-	762
		-	75 510 184 NFP	772
GS GSA	CAD	GX 42 463 01A NFP	-	762
		-	GX 42 464 01A NFP	772
CX				
CX		5 452 434 NFP → 10/74	-	1118
		95 492 972 10/74 →	-	1195
		-	5 452 435 NFP → 10/74	1338
		-	95 492 971 10/74 →	1390

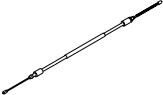

							
4251 10	29-32	4252 72	10	4246 H9 (2)	29-32	95 661 811 (2)	8
4251 12	29	4252 73	10	4246 J3 (2)	29-32	95 661 812 (2)	27
4251 17	33	4252 74	15-19-21	4246 J6 (2)	29	95 661 813 (2)	27
4251 19	33	4252 87	26	4246 J9 (2)	33	95 661 814 (2)	27
4251 28	8-10	4252 88	26	4246 L6 (2)	25	95 661 848 (2)	8
4251 29	25	4252 89	26	4246 L8 (2)	25	95 661 849 (2)	24
4251 37	10	4252 90	26	4246 N3 (2)	36	95 661 850 (2)	46
4251 39	10	95 624 480	46	4246 N5 (2)	36	95 667 811 (2)	25
4251 40	10	95 624 482	46	4246 N7 (2)	36	95 669 224 (2)	39-42
4251 44	14-16-20	95 624 484	24	4246 P2	28-32	95 669 226 (2)	8
4251 45	25	95 647 733	30-42	4246 R4 (2)	13-31		
4251 47	10	95 648 537	30-39-42	4246 R9 (2)	16-17		
4251 50	29-32	95 650 872	46	4246 T2 (2)	27		
4251 55	17-31	95 650 890	24	4246 T3 (2)	27		
4251 56	25	95 650 937	8	4246 T8 (2)	25		
4251 57	25	95 650 938	8	4246 T9 (2)	16-20		
4251 58	25	95 650 995	45	4246 V0 (2)	14-25		
4251 61	47	95 650 996	45	4246 W1 (2)	12-13-20-22-26-31		
4251 62	47	95 653 061	37	4246 W2 (2)	20-22-26		
4251 63	47	95 658 557	14	4246 W3 (2)	26		
4251 70	16-17	95 658 617	8	4246 W4 (2)	26-28		
4251 83	27	95 659 353	14	4246 W6 (2)	14-16-17		
4251 97	15-19-21	95 659 640	27		22-24-25-31		
4252 03	16-17	95 661 798	27	4246 X8	13-23		
4252 05	16-17	95 661 871	8	4246 Y1	33-35		
4252 11	25-27	95 663 076	39-42	4246 Y3	33-35		
4252 13	22	95 666 894	14	4246 Y7	34-35		
4252 18	20	95 666 970	8-14-30	4246 Z1	34-35		
4252 26	33	95 666 972	27	4246 Z8	28		
4252 27	33	95 667 764	36	5 416 277 (1)	47		
4252 31	28-32	95 667 765	36	5 426 184 (1)	47		
4252 33	28	95 667 788	25-27	5 462 434 (1)	46		
4252 34	22			75 485 825 (1)	30-39-42		
4252 35	20			75 529 364 (1)	46		
4252 36	13			95 577 360 (1)	47		
4252 37	12-13			95 599 322 (1)	37		
4252 40	20-22-31			95 661 746 (2)	24		
4252 41	12-13-23			95 661 747 (2)	8-10-14-16-17		
4252 43	33-35			95 661 748 (2)	10-14-30-42		
4252 45	33-35			95 661 749 (2)	11-15-19-21		
4252 47	34-35			95 661 796 (2)	27		
4252 48	26			95 661 810 (2)	8-10		
4252 49	26						
4252 53	22						
4252 55	28						
4252 57	11						
4252 58	12-13						
				(1) 	(2) 		

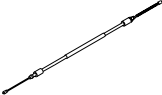
							
00 17 689 400	30	95 659 668	9	4251 59	38-45		
4402 49	41-43	AMN 453 05	38	95 624 483	46		
4402 50	40-43						
4402 58	36						
4402 70	36						
4402 81	36						
4402 85	36						
4402 86	15						
4402 87	15						
4402 90	11						
4402 91	11						
4402 92	11						
4402 93	9-11						
4402 94	9-11						
4402 95	9						
4402 97	15-18						
4402 98	15-18						
4402 A0	15-18						
4402 A1	15-18						
4402 A2	15-18						
4402 A3	34						
4402 A4	34						
4402 A5	34						
4402 A7	29-32						
4402 A8	11-15-18-21						
4402 C6	23-31						
4402 C7	18-21						
4402 C8	11-12-13-21						
4402 E1	13						
4402 E2	13						
4402 E3	13						
4402 E4	34-35						
4402 E8	23-31						
4402 E9	12-13						
5 411 942	38						
5 488 527	38						
75 492 434	37						
75 530 008	37						
95 496 738	43						
95 534 127	41-43						
95 569 738	40-43						
95 608 853	9						
95 608 854	9						
95 659 474	15						
95 659 475	15						
95 659 664	9						
95 659 665	9						

	L = mm			L = mm	
4745 41	770	56	4745 P5	1775	51
4745 80	2255	54	4745 P6	1865	51
4745 96	2600	54	4745 R0 →11/99	1881	52
4745 E8 (2)	–	50	4745 R3	–	52
4745 F2	1065	52	4745 R4	–	52
4745 F3	2235	52	4834 R5 (2)	1838	51
4745 F4	1255	52	4745 T4	1445	50
4745 F5	2200	52	4745 T6	–	52
4745 F6	1618	50	4745 T7	–	52
4745 F8	1590	50	4745 T8	–	52
4745 F9	1540	50	4745 V0	–	50
4745 G1	1500	50	4745 V1	–	50
4745 G3	3047	53	4745 V2	–	53
4745 G5	1265	51	4745 V4	–	53
4745 G6	1335	51	4745 V5	–	53
4745 G7	3027	53	4745 W0	1855	51
4745 G8	2365	52	4745 W1	1945	51
4745 H5	1295	51	4745 W3	–	50
4745 H6	1395	50	4745 W4	–	50
4745 H8	1509	50	4745 W5	–	53
4745 J0	1747	52	4745 W7	–	53
4745 J1	1121	50	4745 W8	–	53
4745 J2	–	53	4745 W9	–	53
4745 J3 →11/99	1821	52	4745 X0	–	53
4745 J4	1365	51	4745 X1	–	53
4745 J5	1335	51	4834 76	2566	54
4745 J8	1275	51	5 455 064	923	54
4745 J9	1185	51	75 491 848	528	55
4745 K0	1260	51	75 492 021	653	55
4745 K1	1277	51	75 492 188	935	54
4745 K2	1260	51	95 492 971	1390	56
4745 K3	1170	51	95 492 972	1195	56
4745 K4	1580	50	95 495 615	1266	55
4745 K5	1490	50	95 604 194	1431	50
4745 K6	1607	50	95 639 111	1067	54
4745 K7	1530	50	96 026 873	1230	51
4745 K8	1610	50	96 026 875	1030	51
4745 K9	1520	50	96 044 362	1418	50
4745 L2	1642	51	96 068 340	1390	51
4745 N1	1300	52	96 092 761	1030	51
4745 N3	1285	51			
4745 N6	1713	52			
4745 N7	1705	52			
(2) 					

☞ Pour connaître les dernières dates de mise à jour, voir DOC FLASH : DIF/DOC/MKSP

DROITS DE PROPRIETE

F "Les droits de propriété intellectuelle relatifs aux informations techniques contenues dans cette brochure appartiennent exclusivement au Constructeur. Toute reproduction et/ou diffusion de tout ou partie de ces informations sont interdites sans autorisation écrite préalable du Constructeur."
"Les informations techniques contenues dans la présente documentation sont destinées exclusivement aux professionnels de la réparation automobile. Dans certains cas, ces informations peuvent concerner la sécurité des véhicules. Elles seront utilisées par les réparateurs automobiles auxquels elles sont destinées, sous leur entière responsabilité, à l'exclusion de celle du Constructeur."
"Les informations techniques figurant dans cette brochure peuvent faire l'objet de mises à jour en fonction de l'évolution des caractéristiques des modèles de chaque gamme.
Nous invitons les réparateurs automobiles à se mettre en rapport périodiquement avec le Constructeur/avec son réseau, pour se procurer les mises à jour nécessaires."

☞ To see the latest update refer to DOC FLASH : DIF/DOC/MKSP

PROPERTY RIGHTS

GB "The intellectual copyrights relating to the technical information contained in this brochure are the exclusive property of the Manufacturer. Any reproduction and/or distribution of all or part of this information is forbidden without the Manufacturer's preliminary written authorisation."
"The technical information contained in this documentation is intended exclusively for automobile repair professionals. In certain cases, the information may relate to vehicle safety.
It will be used by the automobile repairers to whom it is addressed, on their full responsibility, to the exclusion of the Manufacturer's liability."
"The technical information that figures in this brochure may be updated in accordance with the changing features of models in each range.
We would request automobile repairers to get in touch with the Manufacturer/the network at regular intervals, to obtain the necessary updates."

☞ Para conocer las últimas fechas de puesta al día, ver DOC FLASH : DIF/DOC/MKSP

DERECHOS DE PROPIEDAD

E "Los derechos de propiedad intelectual relativos a las informaciones técnicas que figuran en este folleto pertenecen exclusivamente al Constructor. Se prohíbe toda reproducción y/o difusión de la totalidad o parte de estas informaciones sin autorización previa y por escrito del Constructor."
"Las informaciones técnicas que figuran en la presente documentación están destinadas exclusivamente a los profesionales de la reparación de automóviles. En ciertos casos, pueden afectar a la seguridad de los vehículos.
Serán utilizadas por los reparadores de automóviles, a quienes están destinadas, bajo su entera responsabilidad, excluyéndose la del Constructor."
"Las informaciones técnicas que figuran en este folleto pueden ser objeto de actualizaciones en función de la evolución de las características de los modelos de cada gama.
Invitamos a los reparadores de automóviles a ponerse en contacto periódicamente con el Constructor/con su red, para conseguir las actualizaciones necesarias."

☞ Para saber as últimas datas de actualizaçao, ver DOC FLASH : DIF/DOC/MKSP

DIREITOS DE PROPRIEDADE

P "Os direitos de propriedade intelectual relativos às informações técnicas contidas nesta brochura pertencem exclusivamente ao Construtor. Qualquer reprodução e/ou difusão da totalidade ou parte destas informações são proibidas sem a autorização prévia e escrita do Construtor."
"As informações técnicas contidas na presente documentação destinam-se exclusivamente aos profissionais da reparação automóvel. Em certos casos, estas informações podem referir-se à segurança dos veículos.
Serão utilizadas pelos reparadores automóvel a que se destinam, sob a sua total responsabilidade, excluindo a responsabilidade do Construtor."
"As informações técnicas que figuram nesta brochura podem ser objecto de actualizações consoante a evolução das características dos modelos de cada gama.
Os reparadores automóvel são convidados a entrarem periodicamente em contacto com o Construtor/com a sua rede, para obterem as actualizações necessárias."

☞ Die Daten der aktuellen Ausgaben finden Sie in : DOC FLASH : DIF/DOC/MKSP

EIGENTUMSRECHTE

D "Die Rechte auf geistiges Eigentum in Verbindung mit den in der vorliegenden Broschüre enthaltenen technischen Informationen stehen ausschließlich dem Hersteller zu. Jede vollständige oder teilweise Reproduktion und/oder Verbreitung dieser Informationen sind ohne vorherige schriftliche Genehmigung des Herstellers verboten."
"Die in der vorliegenden Dokumentation enthaltenen technischen Informationen sind ausschließlich für Autoreparaturfachleute bestimmt. In einigen Fällen können diese Informationen die Sicherheit der Fahrzeuge betreffen.
Sie werden von den Kraftfahrzeughandwerkern, für die sie bestimmt sind, in ihrer eigenen Verantwortung benutzt, unter Ausschluß der Verantwortung des Herstellers."
"Die in dieser Broschüre enthaltenen technischen Informationen können je nach Fortentwicklung der verschiedenen Modelle in jeder Produktreihe aktualisiert werden.
Wir fordern die Kraftfahrzeughandwerker auf, sich regelmäßig an den Hersteller/an sein Vertriebsnetz zu wenden, um sich die erforderlichen Aktualisierungen zu beschaffen".

☞ Per conoscere l'ultima data agglomerato vedere DOC FLASH : DIF/DOC/MKSP

DIRITTI DI PROPRIETÀ

I "I diritti di proprietà intellettuale riguardanti le informazioni tecniche contenute nel presente manuale appartengono esclusivamente al Costruttore. Qualsiasi riproduzione e/o diffusione di tutto o parte di queste informazioni sono vietate senza autorizzazione preventiva scritta del Costruttore."
"Le informazioni tecniche contenute nella presente documentazione sono destinate esclusivamente agli autoriparatori. In alcuni casi, queste informazioni possono riguardare la sicurezza dei veicoli.
Esse verranno utilizzate dagli autoriparatori ai quali esse sono destinate sotto la loro piena responsabilità, ad esclusione di quella del Costruttore."
"Le informazioni tecniche contenute nel presente manuale possono essere oggetto di aggiornamenti in funzione dell'evoluzione delle caratteristiche dei modelli di ogni gamma.
Invitiamo gli autoriparatori a mettersi in contatto periodicamente con il Costruttore/la sua rete, per procurarsi gli aggiornamenti necessari."

☞ Voor de laatste versiedatum, zie DOC FLASH : DIF/DOC/MKSP

EIGENDOMSRECHT

O "Het individuele eigendomsrecht betreffende technische informatie die in deze brochure staat vermeld behoort exclusief aan de Fabrikant. Alle reproductie en/of verspreiding van alles of een gedeelte van deze informatie is verboden zonder voorafgaande, schriftelijke toestemming van de Fabrikant."
"De technische informatie die in deze documentatie staat vermeld is alleen bestemd voor vakmensen in de branche van de automobielreparatie. In bepaalde gevallen kan deze informatie betrekking hebben op de veiligheid van de wagens.
Deze wordt gebruikt door automobielreparateurs waarvoor zij is bestemd, onder hun volledig verantwoordelijkheid, waardoor die van de Fabrikant vervalt."
"De technische informatie die in deze brochure staat vermeld kan onderhevig zijn aan aanvullingen als gevolg van een ontwikkeling in de technische gegevens van de modellen van elke serie.
Wij vragen de automobielreparateurs zich regelmatig met de Fabrikant of zijn netwerk in verbinding te stellen, om deze noodzakelijke aanvullingen te verkrijgen."