

Chapter 2 Part A:

150 engine

Contents

Cylinder head - dismantling, decarbonising, inspection and reassembly	13	Engine - preparation for reassembly	15
Cylinder head - removal and refitting	6	Engine reassembly - general information	14
Cylinder liners - checking protrusion	16	Engine - reconnection to transmission	18
Engine - complete dismantling	11	Engine - separation from transmission	10
Engine - complete reassembly	17	Engine/transmission - removal and refitting	7
Engine dismantling - ancillary items	9	General information and precautions	1
Engine dismantling - general information	8	Major operations possible with engine in vehicle	3
Engine - examination and renovation	12	Major operations requiring engine removal	4
Engine - initial start-up after overhaul	19	Oil filter - removal and refitting	2
		Valve rocker clearances - checking and adjustment	5

Degrees of difficulty

Easy , suitable for novice with little experience 	Fairly easy , suitable for beginner with some experience 	Fairly difficult , suitable for competent DIY mechanic 	Difficult , suitable for experienced DIY mechanic 	Very difficult , suitable for expert DIY or professional 
------------------------------------------------------------------------------------------------------------------------------------------------	-------------------------------------------------------------------------------------------------------------------------------------------------------	-----------------------------------------------------------------------------------------------------------------------------------------------------	--------------------------------------------------------------------------------------------------------------------------------------------------	---------------------------------------------------------------------------------------------------------------------------------------------------------

2A

Specifications

General

Type	Four-cylinder, in-line, OHC, liquid cooled, transverse mounting
Model application:	
BX	150 A (XY6C)
BX 14 before August 1988	150 C (XY6D)
Bore	75.0 mm
Stroke	77.0 mm
Capacity	1360 cc
Compression ratio	9.3:1
Firing order	1 - 3 - 4 - 2
Location of No 1 cylinder	At clutch end of block
Direction of crankshaft rotation	Clockwise viewed from pulley end
Maximum power DIN (BHP):	
150A engine	62 at 5500 rpm
150C engine	72 at 5750 rpm
Maximum torque DIN (lbf ft):	
150A engine	79.4 at 2500 rpm
150C engine	79.4 at 3000 rpm

Cylinder head

Type	Aluminium alloy, bi-spherical combustion chambers, offset valves and five bearing camshaft
Maximum allowable distortion	0.05 mm
Valve seat maximum contact surface width:	
Inlet	1.45 mm
Exhaust	1.80 mm
Valve seat angle:	
Inlet	120°
Exhaust	90°

2A•2 150 engine

Valves

Stem diameter	8.0 mm
Head diameter:	
Inlet	36.8 mm
Exhaust	29.3 mm
Length:	
Inlet	113.19 to 113.63 mm
Exhaust	113.11 to 114.01 mm
Springs:	
Wire diameter	4.3 mm
Length under load:	
Inlet	41/26 mm/kg
Exhaust	30/77 mm/kg
Rocker clearance (cold):	
Inlet	0.10 to 0.15 mm
Exhaust	0.20 to 0.30 mm

Valve timing

	150 A engine	150 C engine
Valve lift	7.25 mm	8.25 mm
Camshaft identification mark	A	S
Inlet opens*	4° ATDC	0° ATDC
Inlet closes*	29° ABDC	42° ABDC
Exhaust opens*	30° BBDC	43° BBDC
Exhaust closes*	5° BTDC	1° BTDC

*With valve clearance of 0.7 mm

Camshaft

Endfloat	0.07 to 0.17 mm
----------	-----------------

Crankshaft and main bearings

Number of bearings	Five
Crankshaft endfloat	0.07 to 0.27 mm
Thrustwasher thicknesses	2.40, 2.50, 2.55, 2.60 mm
Minimum allowable ovality of crankpins and journals	0.007 mm
Crankpin standard diameter	45.0 mm
Main bearing journals:	
Standard diameter	49.981 to 49.965 mm
Regrind diameter	49.681 to 49.665 mm

Connecting rods

Small-end bush diameter	19.463 to 19.476 mm
Big-end diameter	48.655 to 48.671 mm

Cylinder liners

Type	Cast iron, wet type
Liner base seal	O-ring
Liner protrusion - clamped or without seal	0.10 to 0.17 mm
Maximum allowable projection difference between two liners	0.05 mm
Piston offset	1.0 mm
Grades:	
Piston:	
A	One file mark
B	Two file marks
C	Three file marks

Pistons

Type	Aluminium alloy, two compression and one oil control ring. Gudgeon pin free in piston, interference fit in connecting rod
Piston fitting direction	Arrow mark on crown points to the timing gear (DT)
Gudgeon pin classes	Three, colour-coded to marks on piston crown
Running clearance	0.07 to 0.09 mm

Lubrication system

Pump maximum lobe-to-body clearance	0.064 mm
Minimum oil pressure	3 bar at 4000 rpm
Low pressure warning	0.6 bar
Oil filter (up to July 1988)	Champion C204

	150 A	150 C
Oil capacity:		
New or reconditioned engine	5.0 litres (8.8 pints)	5.5 litres (9.7 pints)
After draining	4.5 litres (7.9 pints)	5.0 litres (8.8 pints)
Dipstick minimum to maximum	1 litre (1.76 pints)	1 litre (1.76 pints)
Torque wrench settings	Nm	lbf ft
Rocker cover	10	7
Rocker adjuster screw locknuts	17	12
Camshaft retaining plate bolt	18	13
Cylinder head bolts:		
Stage 1	50	36
Stage 2	78	56
Crankshaft pulley nut	140	101
Timing cover bolts	12	9
Timing chain guide plate bolts	6	4
Timing chain tensioner (both types)	6	4
Camshaft sprocket bolt	75	54
Oil pressure switch	20	15
Coolant temperature sender unit	45	33
Sump	10	7
Sump drain plug	28	20
Oil suction strainer bolts	10	7
Clutch casing bolts	10	7
Flywheel bolts	68	50
Connecting rod big-end cap bolts	38	27
Gearbox to engine	15	11
Engine mountings:		
A	50	36
B	22	16
C	35	25
Main bearing/casing bolts:		
Stage 1	38	27
Stage 2	53	38
Crankcase flange housing bolts	10	7

1 General information and precautions

General information

The 150 series engine fitted to the Citroën BX and BX 14 models is of 4-cylinder, in-line, overhead camshaft design and mounted transversely.

A manual gearbox is bolted to the bottom of the engine. The final drive to the front roadwheels is via a differential unit on the front of the gearbox. Drive to the gearbox is via a conventional clutch on the left-hand side of the engine, through an input pinion free-running on the crankshaft and located between the clutch and the engine block.

All the major casings and housings are manufactured from pressure die-cast aluminium alloy. The cylinder block has removable wet cylinder liners which are centrifugally cast from special iron alloy and the main bearing caps are made of cast iron. The cylinder head has bi-spherical squish effect combustion chambers, each having one exhaust valve, one inlet valve, and a taper seated spark plug location. Single springs are fitted to the valves which are operated by rockers, each incorporating an adjustable

screw and locknut for valve clearance setting.

The aluminium alloy pistons are fitted with three rings, two compression and one "perfect circle" scraper. The pistons are assembled to the forged steel connecting rods by a gudgeon pin which is a force fit in the connecting rod small-end.

The crankshaft is carried in five main bearings and the flywheel and clutch are bolted to its rear end in conventional manner. The other end is keyed to drive the camshaft chain sprocket and also a shaft by which the oil pump, fuel pump and distributor are driven.

A forced feed lubrication system common to both engine and gearbox is employed. The oil pump is attached to the crankcase in the lower section of the timing chest and it incorporates the pressure relief valve. The pump is driven by gears from the crankshaft. Apart from the standard replaceable canister filter located on the outside of the crankcase there is a gauze filter incorporated in the oil pump suction inlet.

Precautions

Because of the unusual layout of the engine and transmission systems, extra care and attention are necessary during maintenance and overhaul procedures which, in many instances, differ from more conventional systems.

Read through the various Sections concerned before tackling any job, and analyse the instructions, so that any snags or possible difficulties can be noted in advance. Because the sub-assembly castings are made from aluminium alloy it is of utmost importance that, where specified, all fastenings are tightened to the correct torque and, in some instances, in the correct sequence.

2 Oil filter - removal and refitting



Refer to Chapter 1, Section 9.

3 Major operations possible with engine in vehicle

Note: Some of these tasks can only be achieved with the aid of special Citroën tools.

The following operations are possible with the engine in the vehicle:

- Removal and refitting of the cylinder head
- Removal and refitting of the clutch unit
- Removal and refitting of the engine mountings
- Removal and refitting of the timing case



6.7 Exhaust downpipe ball socket connection

4 Major operations requiring engine removal

The engine must be removed for the following operations:

- a) Removal and refitting of the transmission
- b) Removal and refitting of the crankshaft and main bearings
- c) Removal and refitting of the piston and connecting rod assemblies
- d) Renewal of the big-end bearings

5 Valve rocker clearances - checking and adjustment

Refer to Chapter 1, Section 21.

6 Cylinder head - removal and refitting

Note: Citroën tool no 701 2-T will be needed to hold the camshaft sprocket and prevent the timing chain from falling down into the timing case.

Note: The following operation was carried out with the engine in the vehicle.

Removal

1 The cylinder head can be removed and refitted with the engine in position in the vehicle, but a Citroën special tool will be required to hold the camshaft sprocket and prevent the timing chain from falling down into the timing case. This tool (part no 701 2-T) comprises three items, referred to as N1, N2 and N3.

2 When the cylinder head is being removed, there is a risk of disturbing the wet liners in their locations. Because of this, certain checks are necessary to confirm that the liners are correctly located. If it is found that they are not within permissible limits, new O-rings will have to be fitted between the liners and the cylinder block. This job will entail removal of the engine/transmission from the car and the virtual complete dismantling of the unit on the bench. It can be seen that removing the cylinder head on this engine, when installed, should only be undertaken if full facilities are available to remove and dismantle the engine even though they may

not be required. Alternatively, be prepared to have the car towed to your Citroën agent if the liner O-rings have to be removed.

- 3 Disconnect the battery earth lead.
- 4 Drain the cooling system.
- 5 Drain the engine/gearbox oil.
- 6 Raise and support the vehicle on safety stands.
- 7 From underneath the vehicle, undo the two retaining nuts and disconnect the exhaust downpipe at the ball socket connection (see illustration). Disconnect the warm air feed pipe.
- 8 Disconnect the following hoses (see illustration) and position them out of the way:
 - a) Heater hoses at the bulkhead
 - b) Coolant pump hoses, or unbolt the pump
 - c) Cylinder head hose
 - d) Thermostat hose
 - e) Heater hoses to the carburettor
 - f) Carburettor fuel feed and return hoses.
 Plug or clamp these hoses
- 9 Disconnect the ignition HT and LT wiring from the plugs and distributor. Position the wiring harness out of the way.
- 10 Remove the spark plugs.
- 11 Disconnect the accelerator cable from the carburettor and position it out of the way.
- 12 Remove the cooling system de-aerator unit.
- 13 Remove the hose carrier from the timing cover.
- 14 Unbolt and remove the fuel pump and withdraw the operating rod.
- 15 Remove the distributor.
- 16 Unbolt and remove the rocker cover.
- 17 Disconnect the following items, noting their connections:
 - a) Idle cut-off lead from the carburettor
 - b) Coolant temperature sensor lead
 - c) Earth cables to the cylinder head
 - d) The Econoscope vacuum hose on the inlet manifold
- 18 Unscrew and remove the first extended head bolt and then the end plate which is secured by two bolts (see illustration). Loosen but do not remove the second extended head bolt.
- 19 Unscrew and remove the bolt retaining the timing gear to the end of the camshaft. Do not disturb the gear as the bolt is withdrawn.

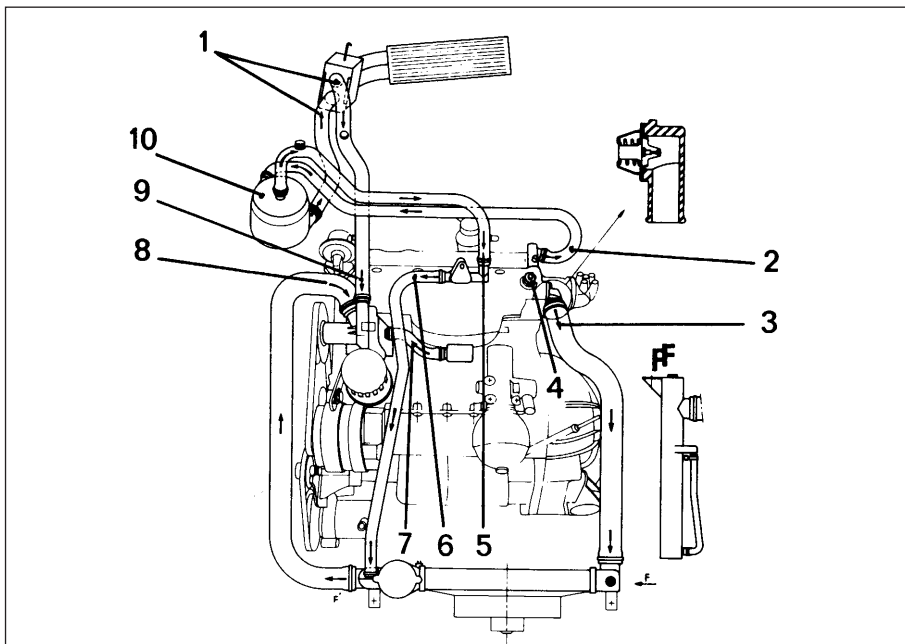

6.8 Cylinder head removal - engine in vehicle. Disconnect items indicated

- | | | |
|----------------------|----------------------------|--------------------|
| 1 Heater hoses | 4 Water temperature sensor | 7 Water pump hose |
| 2 Cylinder head hose | 5 Carburettor hose | 8 Water pump hose |
| 3 Thermostat hose | 6 Carburettor hose | 9 Water pump hose |
| | | 10 De-aerator unit |

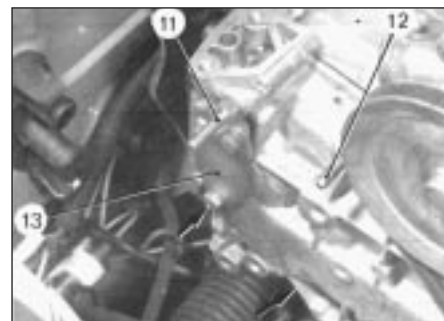

6.18 Extended head bolts (11 and 12) and end plate (13)

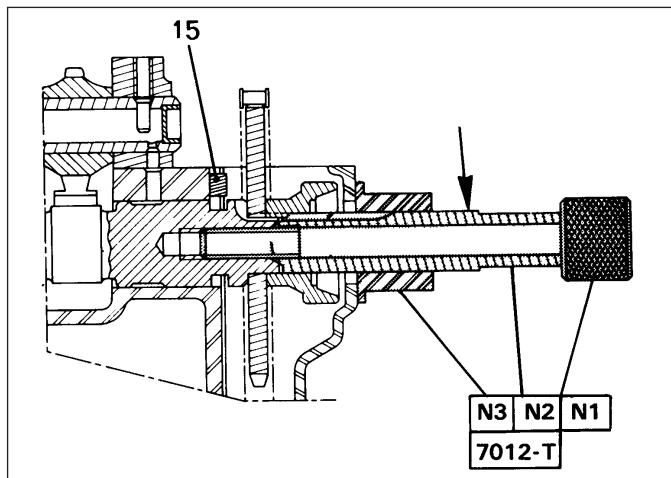

6.20 Fitting position of Citroën tool 7012-T in camshaft. Camshaft retaining plate indicated (15)

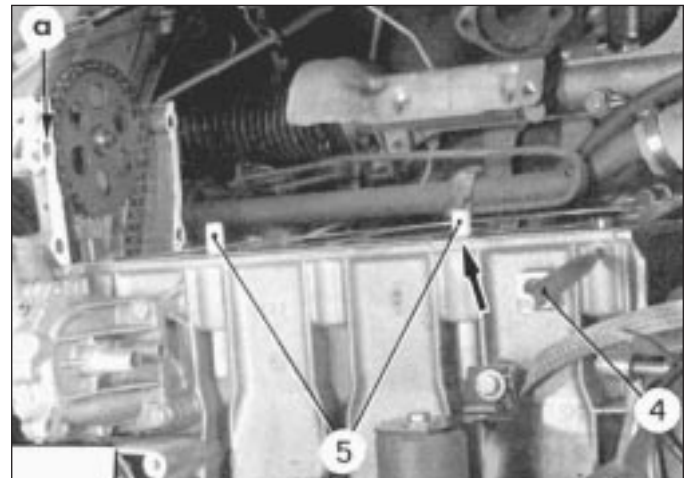

6.30 Dowel stop rod (4) guide pins (5) and timing cover extended screw (a)

20 Lubricate the special tool (701 2-T) with oil and fit it into position. Fit the clamp onto the timing case, but do not fully tighten the bolts. The mandrel groove must engage with the fuel pump control cam pin. Tighten the mandrel onto the camshaft. The camshaft and mandrel grooves must be in alignment (see illustration). Mark the relative positions.

21 Turn the engine over slowly so that the mandrel groove mark can be seen to be positioned within the upper quarter of the timing cover face. In this position fully tighten the clamp bolts.

22 Loosen the camshaft retaining plate bolt and withdraw the plate from its groove, then retighten the bolt.

23 Position a piece of modelling clay or similar compound under the front left-hand cylinder head nut to keep it in position when the bolt is removed. Following the tightening sequence in reverse, progressively loosen the 10 cylinder head bolts. As the bolts are loosened, the rocker shaft assembly will lift under the influence of the valve springs. Remove the bolts and the rocker shaft assembly.

24 Loosen the special tool (N1) from the camshaft and slide the camshaft away from the gear by hand. When the camshaft is clear of the gear the cylinder head can be removed. If it appears to be stuck, insert two bars into cylinder head bolt holes, taking care not to damage the head, and rock it free of the block. Do not, on any account, hammer on the cylinder head as it can be damaged very easily. Fit temporary restraining straps made of strip material to the block to keep the cylinder liners in position; secure them with bolts and nuts in the cylinder head bolt holes.

25 Carefully cut and remove the upper, exposed portion of the timing case gasket level with the face of the cylinder block. Clean the mating faces of the block, cylinder head, and timing case free of all jointing materials. Do not use emery cloth or sharp-edged tools as the surfaces must be free of all traces of scores, burns, or impact damage.

26 Note that on engines manufactured after December 1985, the cylinder head location dowels are of a reduced diameter, that is, from 16 mm to 14 mm. The cylinder head gasket is modified to suit. In certain instances (e.g. fitting a new-type head to an old-type block) the use of stepped dowels will be necessary - these are available from Citroën dealers. Ensure that the combination of dowels and gasket is correct.

27 If there is likely to be an appreciable time lapse before reassembly, cover the exposed parts of the engine internals with clean, fluff-free rag.

Refitting

28 Before refitting the cylinder head, check the cylinder liner protrusions.

29 Check that the location dowels are in position in the cylinder block top face. To prevent the rear dowel from being pushed down when fitting the cylinder head, insert a suitable rod into the hole in the crankcase side wall directly beneath the dowel.

30 Locate two guide pins in the cylinder block (see illustration). The pins should be 11 mm in diameter and no more than 95 mm long.

31 Lubricate the cylinder walls with clean engine oil. Remove the cylinder liner retaining straps.

32 Locate the new cylinder head gasket. It must be fitted dry and the arrow mark must point towards the front of the engine. Smear the timing cover mating faces with a suitable sealant.

33 Loosen the rocker adjustment screws.

34 Carefully lower the cylinder head into position on the block and then fit the rocker assembly into position on the cylinder head (see illustrations).

35 Note that on engines manufactured after December 1985, the rocker assembly has a location dowel on each pedestal, instead of one at each end as on earlier models (see illustration). The cylinder head also has corresponding dowel holes. At the same time, the rocker cover retaining screw holes are increased in diameter, and are now 8.5 mm (previously 7.5 mm). The location holes in the rocker assembly are correspondingly increased, and larger bolts used. Ensure any new components are of the correct type. From February 1987, the rocker arms, shaft and rocker cover were further modified. These components can be fitted to earlier engines, provided all the arms, shaft and cover are fitted at the same time.

36 Fit the cylinder head bolts and nuts but leave them untightened for the moment. Remove the guide pins and the dowel support rod.



6.34a Lower cylinder head into position . . .

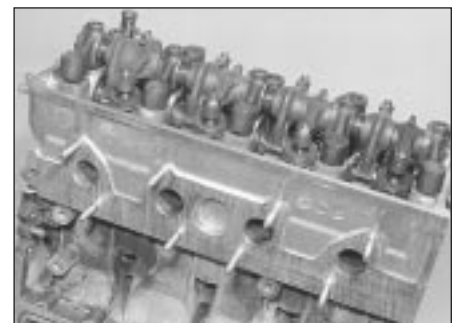

6.34b . . . then fit rocker assembly onto cylinder head

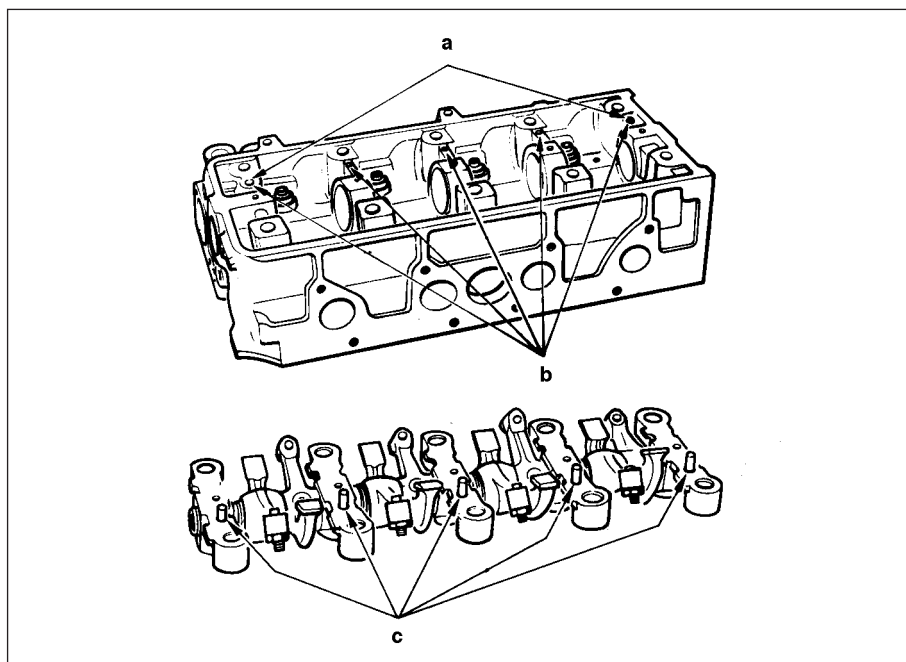

6.35 Rocker assembly positioning dowels

a Early models b Later models c Dowel locations on later rocker assembly

37 Locate the timing cover extended head bolt into position (see illustration 6.30) but do not fully tighten it.

38 Align the grooves of the camshaft and the mandrel and tighten it into position. Push the timing gear and the camshaft together ensuring correct engagement. If necessary tap the rear end of the camshaft with a soft-faced mallet.

39 Fit the camshaft retaining plate into its groove and tighten the bolt to the specified torque.

40 Tighten the cylinder head bolts in the sequence shown. The bolts must be tightened in two stages to the specified torque settings (see illustration).

41 Remove the special tool (7012-T) then

refit the gear/camshaft retaining bolt and tighten it to the specified torque.

42 Refit the timing cover bolts and tighten them to the specified torque. Before refitting the timing case closing plate smear the mating edges with sealant.

43 Adjust the rocker/valve clearances.

44 Refitting of the remaining components is a reversal of the removal procedure, but note the following special points:

- Tighten fasteners to the specified torque settings
- Refill the cooling system and top-up the engine/gearbox oil
- Before restarting the engine, check that all tools and equipment are removed from the engine compartment

- Check the ignition timing and, when the engine is warmed up, adjust the idle speed
- After starting the engine, check for leaks and then run it until the cooling fan engages. Stop the engine and when it is cool top-up the cooling system
- After the engine has been allowed to cool for at least two hours, the cylinder head bolts must be retightened. First remove the rocker cover and, following the sequence shown in illustration 6.40, slacken the first bolt and then retighten it to the Stage 2 specified torque. Then slacken the second bolt and retighten it, and so on until all bolts have been separately retightened
- Following the retightening of the cylinder head bolts, the inlet and exhaust valve clearances must be reset

7 Engine/transmission - removal and refitting



Removal

1 The engine/transmission must be removed as a complete assembly and cannot be separated until removed. Certain operations are awkward and care must be taken not to damage adjacent components in the engine compartment, especially during removal. It is necessary to have an assistant readily to hand. Start by removing the bonnet.

2 Chock the rear wheels then raise the vehicle at the front so that the front roadwheels are clear of the ground. With the vehicle supported on safety stands, remove the front roadwheels.

3 Disconnect the positive and negative leads from the battery.

4 Disconnect the earth wires from the cylinder head.

5 Remove the battery and its plastic tray from the engine compartment.

6 Detach and remove the air cleaner unit.

7 Disconnect the following (see illustration):

- The HT lead at the coil
- The diagnostic plug negative and positive wires at the coil
- The wiring connector at the distributor
- The Econoscope wiring harness
- The Econoscope vacuum inlet tube

8 Disconnect the clutch inner cable from the operating lever clevis (see illustration).

9 Undo and detach the speedometer drive cable at its transmission connection. Fold the cable back out of the way.

10 Disconnect and remove the air inlet duct from the wing panel.

11 Disconnect the choke cable and the accelerator cable at the carburettor.

12 Detach the fuel feed hose from the fuel pump and the fuel return hose from the carburettor. Plug the hoses and connections to prevent excessive leakage and the ingress of dirt.

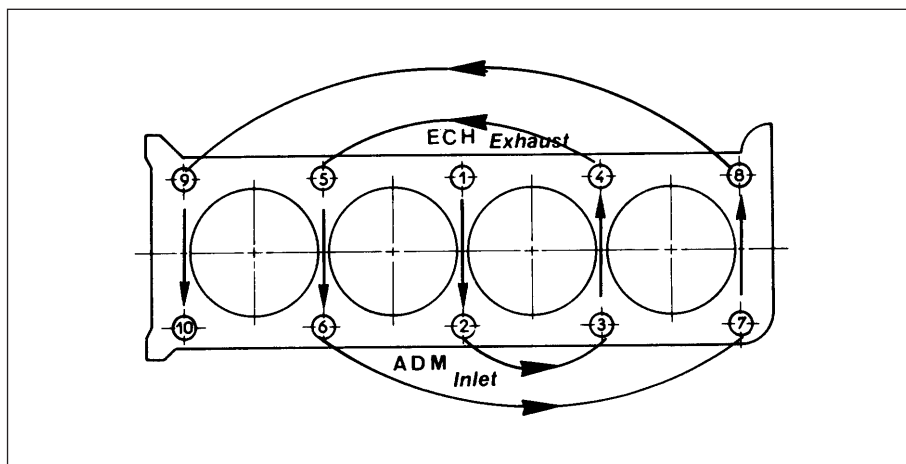

6.40 Sequence for tightening cylinder head bolts

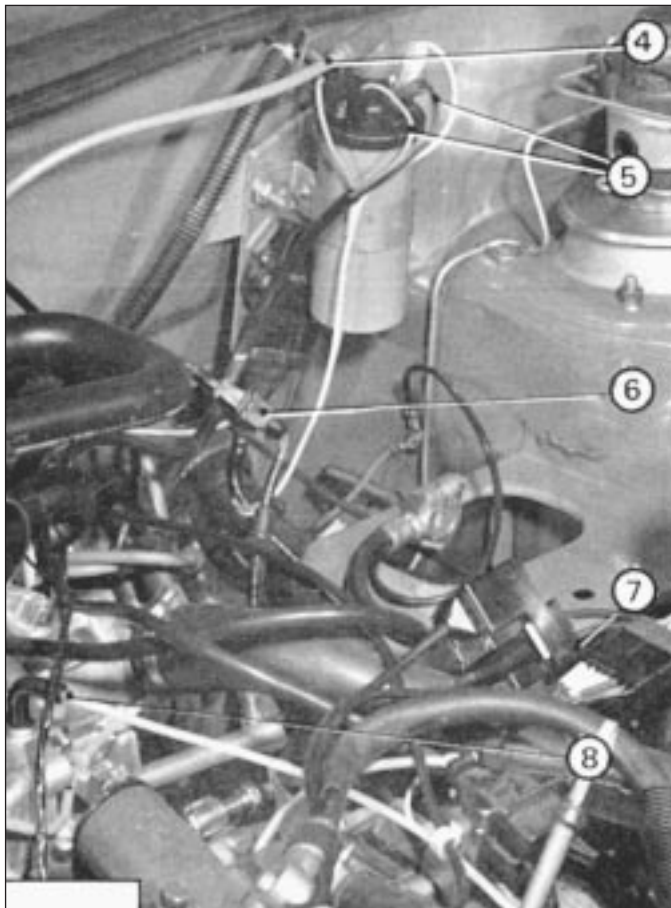

7.7 View showing items to be disconnected

- | | |
|-------------------------|------------------------|
| 4 Coil HT lead | 7 Econoscope connector |
| 5 Coil leads | 8 Econoscope tube |
| 6 Distributor connector | |

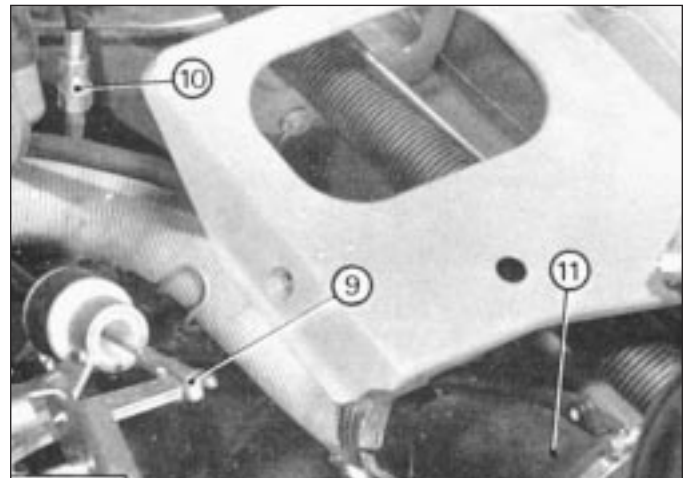

7.8 Disconnect clutch cable (9) speedometer cable (10) and air inlet duct (11)

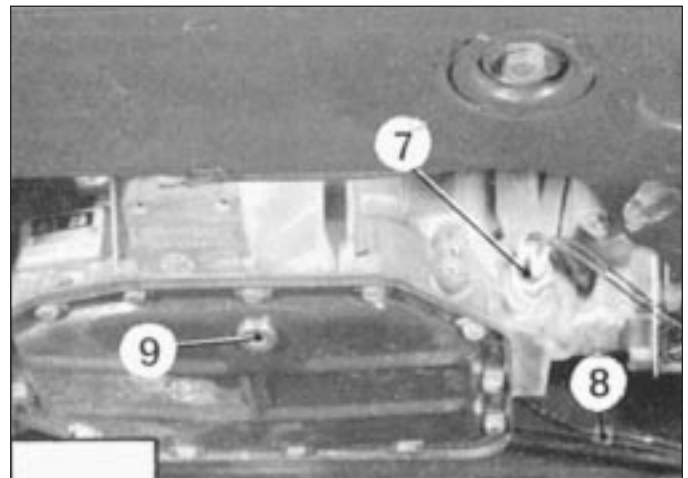

7.19 View showing reversing lamp switch (7) wiring harness clip (8) and sump drain plug (9)

13 Drain the cooling system.

14 Disconnect and detach the heater flow and return hoses at the coolant pump, the inlet manifold heater hose and the cylinder head-to-radiator coolant hose.

15 Disconnect the wiring connectors from the cooling fan temperature sensor and the coolant level sensor at the radiator.

16 Undo the five radiator top panel retaining bolts. Remove the panel and the radiator, taking care not to damage its core as it is lifted out.

17 Detach and remove the de-aeration chamber from its support on the right-hand side of the engine compartment.

18 Position a suitable container under the sump then remove the drain plug and drain the engine oil.

19 Detach the reversing lamp switch leads and detach the wiring harness from the retaining clip (see illustration).

20 Release the pressure from the hydraulic system.

21 Disconnect the oil suction pipe from the

high pressure (HP) pump. Clean the connections and plug the ports to prevent the ingress of dirt (see illustration).

22 Disconnect the oil return pipe and outlet pipe from the pressure regulator unit (see illustration). Clean the connectors and plug the ports to prevent the ingress of dirt.

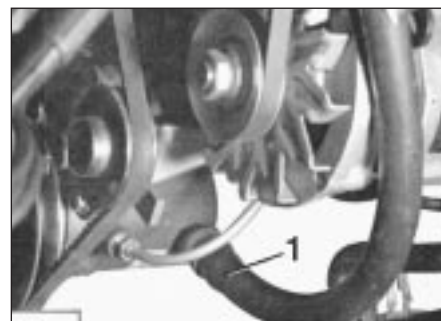

7.21 Disconnect oil suction pipe (1) from HP pump

23 Disconnect the hydraulic outlet pipe from its location lug and the two pipes from the lugs on the engine front face.

24 Disconnect the link rods from the gearbox.

25 Disconnect the exhaust downpipe at the balljoint.

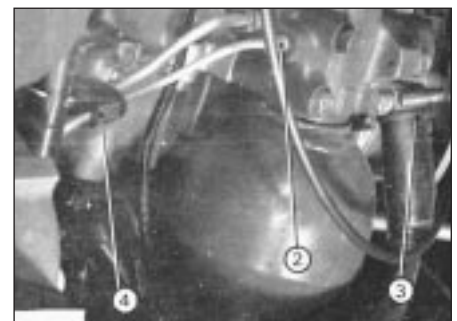

7.22 Disconnect oil return pipe (3) outlet pipe (2) and securing lug (4) at pressure regulator unit

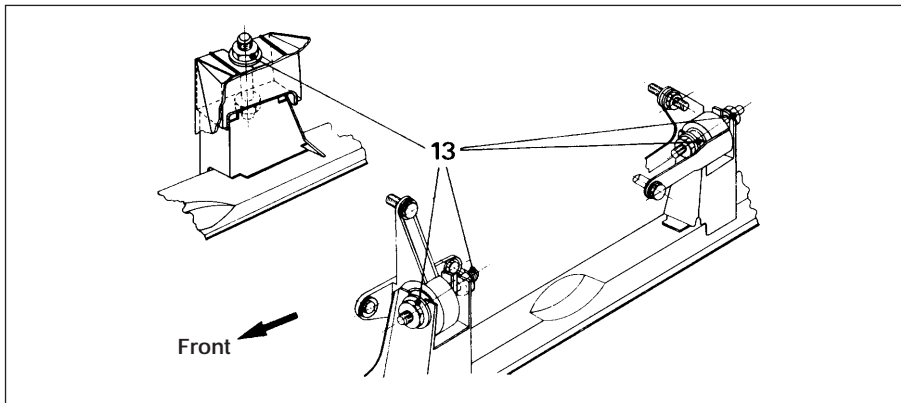

7.29 Undo engine mounting nuts (13)

26 The steering link rods and lower wheel arm balljoints must now be separated. Loosen the retaining nuts and use a suitable separator to disconnect the joints.

27 Pull the driveshafts outwards and release them from the transmission. Support the shafts so that they are out of the way without damaging their rubber gaiters or straining their joints.

28 Connect a sling to the lift brackets at each end of the cylinder head. Lift and just take the weight of the engine/transmission.

29 Unscrew and remove the engine mounting nuts (see illustration).

30 Check that the engine and associated components are fully disconnected and positioned so that they will not be damaged or interfere with engine/transmission removal.

31 Lift the engine/transmission clear of the mountings then guide the unit upwards out of the engine compartment. An assistant will be necessary to steady the unit as it is removed.

32 Once removed from the vehicle, the engine/transmission can be cleaned externally then moved to the work area for dismantling and overhaul.

Refitting

33 Refitting of the engine/transmission is, in general, the reverse of the removal procedure but note the following points.

34 Check that the lift sling is securely located before lifting the unit into position.

35 Check that all loose hoses, wires, hydraulic pipes and components in the engine bay are moved out of the way as the unit is lowered into position.

36 When reconnecting the driveshafts, take care not to damage the oil seals and ensure that the shafts are fully located.

37 Renew the engine mounting self-locking nuts, also those of the lower wheel arm and steering link rod balljoints.

38 Tighten all mounting and connecting bolts and nuts to the specified torque settings (see illustration).

39 Refer to the appropriate Chapter when reconnecting the choke and accelerator cables.

40 Refer to the appropriate Chapter when connecting and adjusting the clutch cable.

41 Check that the cooling system, fuel system and hydraulic system hoses are in good condition before reconnection.

42 Check that all electrical connections are correctly and securely made.

43 Top-up the cooling system.

44 Top-up the engine/transmission oil level.

45 Retighten the hydraulic system pressure regulator bleed screw and top-up the hydraulic fluid level as necessary. The system will need to be repressurised as soon as the engine is started.

46 Go carefully round the engine to make sure that all reconnections have been made. Especially check that the electrical earth connections are made, the drivebelts are correctly tensioned, the carburettor controls are connected and that there are no apparent oil or coolant leaks. Remove all loose tools, rags, etc.

47 Refit the battery and secure with its clamp plate. Reconnect the battery leads and check the operation of the electrical circuits.

48 The engine is now ready for its initial start-up.

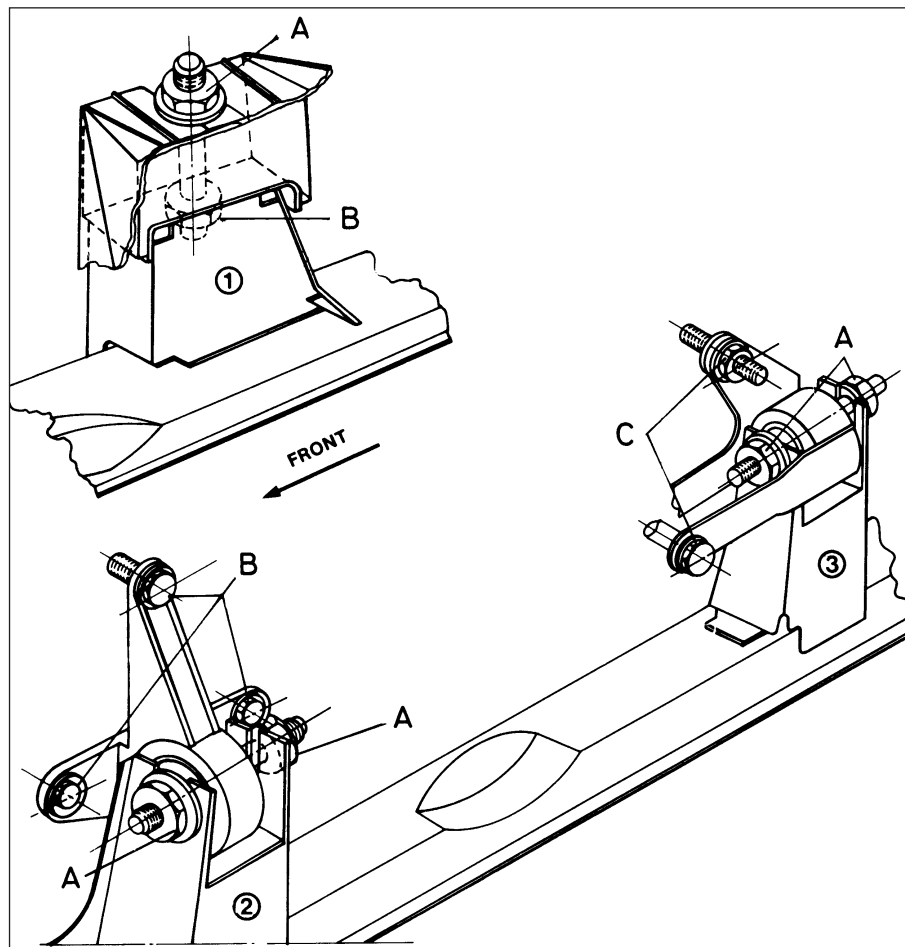

7.38 Engine mountings and securing bolts (refer to the Specifications for torque settings)

8 Engine dismantling - general information

1 A clean and good sized work area will be required, preferably on a bench. Before moving the engine/transmission to the work area it should be cleaned to remove road dirt, oil and grease.

2 During the dismantling process, care should be taken to avoid contaminating exposed internal parts of the engine with dirt. Although everything will be cleaned separately before reassembly, road dirt or grit can cause damage to parts during dismantling and could also affect inspection and checks.

3 A good proprietary grease solvent will make the job of cleaning much easier but if this is not available then use paraffin. With a solvent the usual procedure is to apply it to the contaminated surfaces and, after a suitable soaking period has elapsed, to wash it off with a jet of water. Where the grease or oil and dirt mixture is encrusted, the solvent should be worked in using a stiff brush.

4 After rinsing off the solvent and dirt, wipe down the exterior of the unit and then, only when the unit is clean and dry, start the dismantling process.

5 As the unit is stripped, individual parts should be examined before being washed in a bath of paraffin and wiped dry. The examination need only be cursory at this stage but it is sometimes helpful as the cleaning procedure might wash away useful evidence of running conditions. Avoid immersing parts with internal oil passages, such as the crankshaft and the timing case. To clean such parts, use a paraffin-damped rag and clean out the oilways with wire. If an air supply is available, then the oilways can be blown through to clear them.

6 The re-use of old gaskets or oil seals is a false economy and can lead to fuel, oil or coolant leaks, if nothing worse. To avoid the possibility of such problems, always use new gaskets throughout.

7 A suggested procedure for dismantling is to remove the clutch assembly and then the timing mechanism (this order could be reversed if required) followed by the transmission, cylinder head, crankshaft and piston assemblies. A supply of wooden blocks of varying sizes will be useful in supporting the engine as it is being worked on.

8 Wherever possible, refit nuts, bolts and washers finger-tight from wherever they were removed as this helps avoid later loss or muddle. If they cannot be refitted, lay them out in such a fashion that it is clear where they came from. Make sketches or notes if you think you may forget the position of washers, etc.

9 Engine dismantling - ancillary items

1 Irrespective of whether you are going to dismantle the engine completely and rebuild it, or are simply going to exchange it for a new or reconditioned unit, the ancillary components will have to be removed.

2 The only possible method of determining the exact condition of the engine and assessing the extent of reconditioning required is to dismantle it completely. If,

having done this, it is decided that a reconditioned short block is needed then the unit can be loosely reassembled, but check that a replacement is available first.

3 Refer to the appropriate Chapters and remove the following components or assemblies:

- a) Distributor
- b) Fuel pump and operating plunger
- c) Carburettor
- d) Inlet and exhaust manifolds
- e) Coolant pump and drivebelt
- f) Alternator and starter motor
- g) Diagnostic socket and wiring harness
- h) Coolant temperature sender
- i) Oil pressure sender
- j) Thermostat and housing
- k) Oil filter and dipstick tube
- l) Clutch assembly
- m) Hydraulic system HP pump unit
- n) Pressure regulator unit
- o) The support mounting

4 If the engine is to be exchanged, check what ancillary items are included in the exchange unit.

10 Engine - separation from transmission



2A

1 If the engine is to be dismantled for overhaul, refer to the previous Section and remove the items listed, then in addition remove the flywheel, as described below.

2 If the two units are to be separated but the engine is not being dismantled, remove the items indicated (**see illustration**) whilst referring to the appropriate Chapters for details where necessary.

3 When the clutch unit is removed, unbolt and remove the flywheel. The retaining bolt positions are not symmetrical so there is no need to mark the fitted position of the flywheel.

4 Unscrew and remove the two bolts and the single nut securing the engine and transmission joint faces at the flywheel end (**see illustration**).

5 If still in position, unbolt and remove the rocker cover.

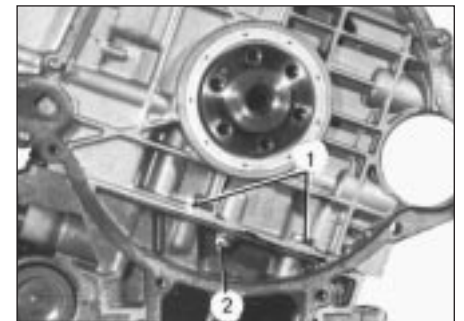

10.4 Engine-to-transmission securing bolts (1) and nut (2) at flywheel end

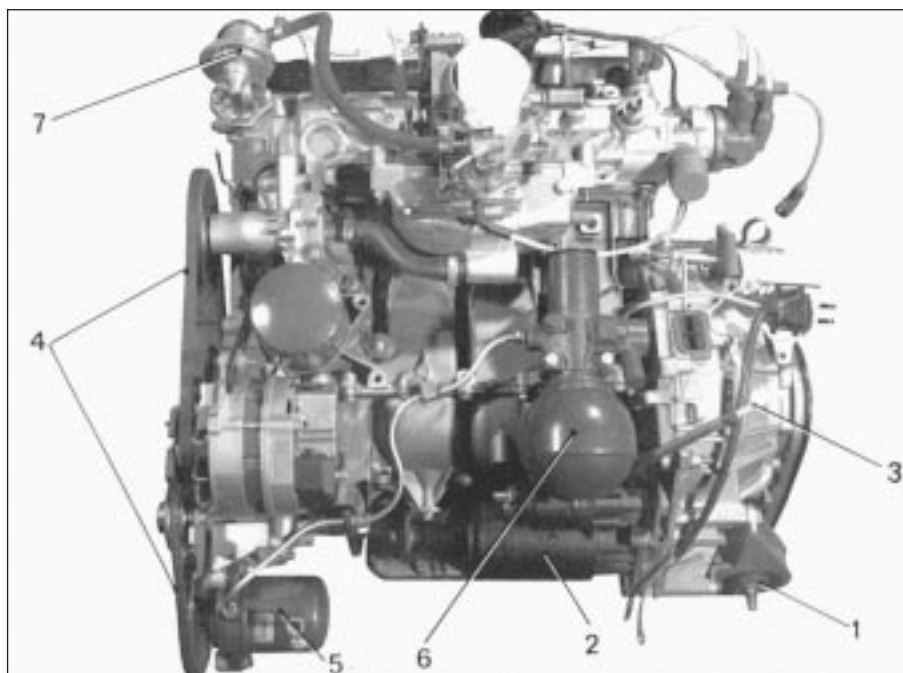

10.2 Items to be disconnected to separate engine from gearbox if engine is not being dismantled

- | | | |
|---------------------------|-------------------------------------|---------------------------|
| 1 Engine support mounting | 4 Alternator and HP pump drivebelts | 6 Pressure regulator unit |
| 2 Starter motor | 5 HP pump unit | 7 Fuel pump |
| 3 Dipstick tube | | |

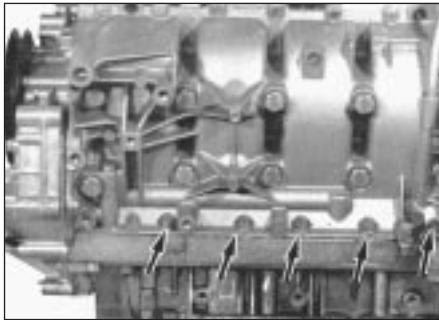

10.9a Engine-to-transmission securing bolts (arrowed) - inlet side



10.9b Engine-to-transmission securing bolts (arrowed) - exhaust side at timing cover end



10.9c Engine-to-transmission securing bolts (arrowed) - exhaust side at flywheel end

6 Unbolt and detach the HP pump drive pulley from the crankshaft inner pulley. Undo the central retaining bolt and remove the crankshaft pulley. To prevent the crankshaft from turning when undoing the bolts, fit two flywheel bolts into the crankshaft rear end and jam a bar diagonally between the bolts.
7 Unscrew and remove the timing cover retaining bolts. As they are withdrawn note the respective bolt sizes and fitted positions to ensure correct refitting.

8 Carefully remove the timing cover. If it is stuck, gently break the joint by tapping it free with a soft-faced hammer, but do not use excessive force as the light alloy casing can easily be damaged. Remove the timing cover gasket (this must be renewed when reassembling). Retrieve the fuel pump pushrod.
9 Unscrew and remove the engine-to-transmission retaining bolts on each side (see illustrations).
10 Support the engine then prise the transmission away from the engine using a suitable length of wood. Take care not to damage the casings. If the two assemblies are reluctant to part, check that there are no retaining bolts or nuts left in position.

5 Unbolt and remove the chain guide plate.
6 Unscrew the camshaft sprocket bolt. The crankshaft must be held against rotation for this operation. Do this by screwing two bolts into the flange and passing a long lever between them.
7 Remove the fuel pump eccentric cam.
8 Remove the oil pump socket-headed screws. Some of these are accessible through the holes in the oil pump driven gear.
9 Remove the oil pump and backplate (see illustration).
10 Withdraw the camshaft sprocket, timing chain and crankshaft sprocket with Woodruff key (see illustration).
11 Unscrew and remove the spark plugs.
12 Remove the cylinder head bolts by unscrewing them in the reverse order to the tightening sequence.
13 Lift off the rocker assembly.



11.3a Loosening first type chain tensioner

11 Engine - complete dismantling



1 Support the engine securely on strong, clean work surface.
2 Remove any remaining engine ancillary items.
3 Loosen the timing chain tensioner. One of two types will be fitted. With the first type, retract the tensioner by turning the lock in an anti-clockwise direction (see illustration). With the second type, use a screwdriver as shown and press down the tensioner to release it (see illustration).
4 Unbolt and remove the chain tensioner.

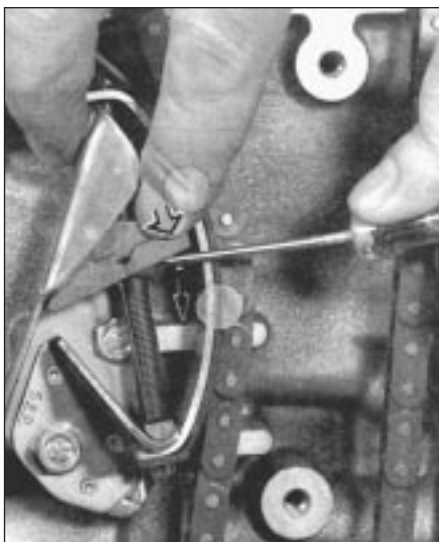

11.3b Releasing second type chain tensioner

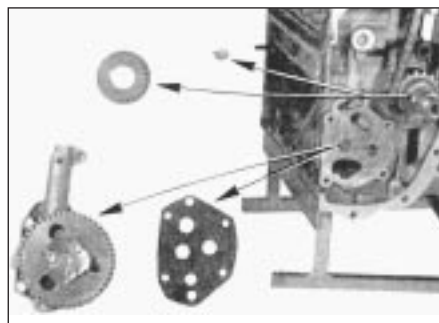

11.9 Oil pump and backplate removal

14 Drive down a cylinder head positioning dowel so that the cylinder head can be swivelled rather than lifted from the block. This is to prevent disturbing the cylinder liner base seals. If the liners are to be removed then obviously this precaution is not necessary, neither is the need to fit cylinder liner clamps to hold the liners down once the cylinder head has been removed.
15 Unscrew and remove the bolts which hold the crankcase half sections together (see illustration).
16 Split the crankcase and keep the main bearing shells with their crankcase web recesses if the shells are to be used again.
17 Remove the crankshaft oil seal.
18 Mark the rim of the cylinder liners in respect of position in the block and orientation (see illustration).
19 Mark the big-end caps and the connecting rods so that they can be refitted in their original sequence and the correct way round. A centre punch or hacksaw blade is useful for this purpose.
20 Unscrew the big-end nuts and remove the caps. If the bearing shells are to be used again, keep them taped to their respective cap or connecting rod.
21 Lift the crankshaft from its crankcase half section, keep the shell bearings in their

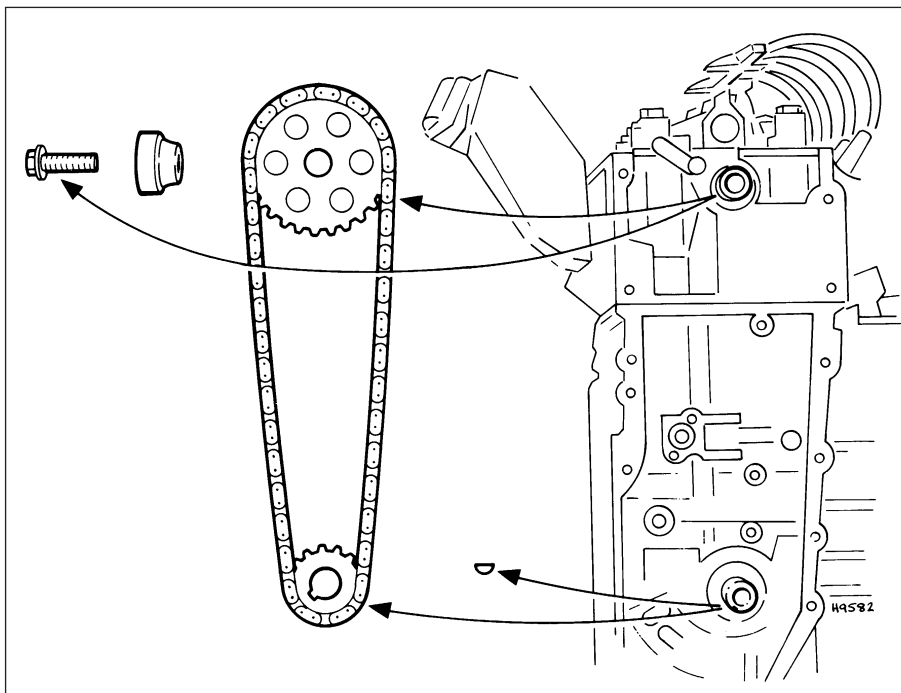

11.10 Timing chain and sprockets removal

original web recesses if they are to be used again and retrieve the semi-circular thrustwashers from either side of Number 2 web.

22 Remove each liner/piston/connecting rod as an assembly from the crankcase. Use a plastic-faced or wooden mallet to tap the liners out if necessary. Make sure that the liners and their respective piston rod assemblies are marked as to position in the block and orientation. A spirit marker is useful for this purpose.

23 Discard the liner base seals which must be renewed.

12 Engine - examination and renovation



General information

1 With the engine dismantled, all components must be thoroughly cleaned and examined for wear, as described in the following Sections.

2 If a high mileage has been covered and general wear is evident, consideration should be given to replacing the engine with a reconditioned unit.

3 If a single component has malfunctioned and the rest of the engine is in good condition, endeavour to find out the cause of its failure if

not readily apparent. For example, if a bearing has failed, check that the adjoining oilways are clear. A new bearing will not last long if it is not being lubricated.

4 If uncertain about the condition of any components then seek a second opinion, preferably from a Citroën dealer who will have an expert knowledge of your model and be able to advise on the best course of action.

5 Check on the availability of replacement parts before discarding old ones. Check the new part against the old to ensure that you have the correct replacement.

6 Some of the measurements required will need the use of feeler blades or a micrometer, but in many instances wear will be visually evident or the old component can be compared with a new one.

7 Take care not to damage mating surfaces when cleaning old sealant and/or gaskets from them.

Crankshaft and main bearings

8 Carefully examine the crankpin and main journal surfaces for signs of scoring or scratches and check the ovality and taper of each journal in turn. Use a dial gauge and V-blocks and check the main bearing journals for ovality. If any journals are found to be more than the specified amount out of round then they will have to be reground. If the crankpins are scored or scratched, do not bother measuring them as they will have to be reground.

9 If a bearing has failed after a short period of operation, look for the cause and rectify before reassembly.

10 If the crankshaft is to be reground this will have to be done by your Citroën dealer or a competent automotive engineer. They will also be able to supply the new shell bearings to suit the undersize requirement. New thrustwashers to control endfloat will also be supplied.

11 Main bearing shells themselves are normally a matt grey in colour all over and should show no signs of pitting, ridging or

2A

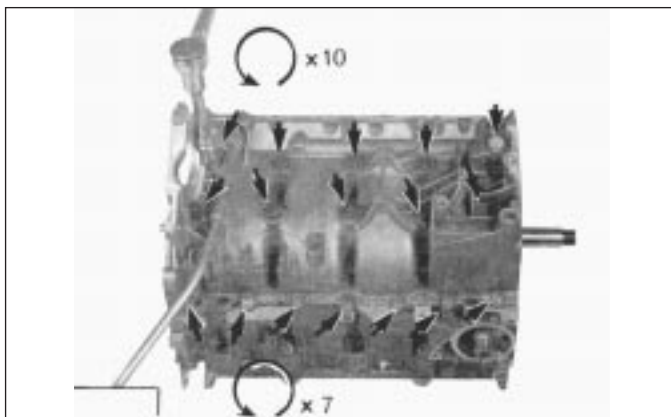

11.15 Crankshaft half casing retaining bolt locations (arrowed)

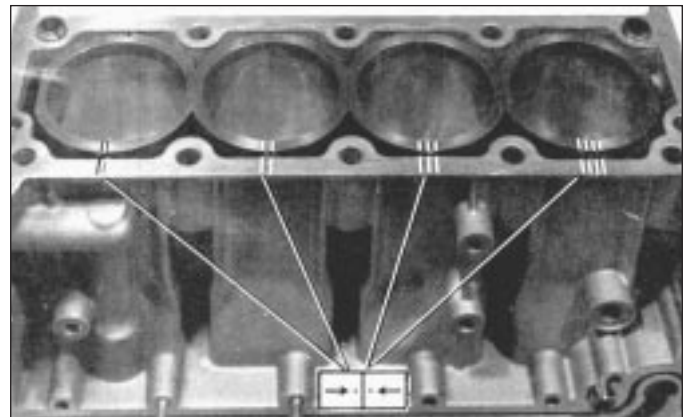

11.18 Cylinder liners and block match marks

discolouration as this usually indicates that the surface bearing metal has worn away and the backing material is showing through.

The shells must be renewed if there is any sign of damage or if the crankshaft has been reground. It is worthwhile renewing the bearing shells anyway if you have gone to the trouble of removing the crankshaft.

12 If the crankshaft is not being reground yet bearing shells are being renewed, make sure that you check whether or not the crankshaft has been reground before. This will be indicated by looking at the back of the bearing shells and will show whether it is undersize or not. The same type of shell bearing must be used when they are renewed.

Big-end bearings

13 Big-end bearings are subject to wear at a greater rate than the crankshaft journals. A sign that one or more big-end bearings are getting badly worn is a pronounced knocking noise from the engine, accompanied by a significant drop in oil pressure due to the increased clearance between the bearing and the journal permitting oil to flow more freely through the resulting larger space.

14 If this happens in an engine which has been neglected, and oil changes and oil filter changes have not been carried out as they should have been, it is most likely that the rest of the engine is in a pretty terrible state anyway. If it occurs in an engine which has been recently overhauled, then it is almost certainly due to a piece of grit or swarf which has got into the oil circulation system and finally come to rest in the bearing shell and scored it. In these instances renewal of the shell alone accompanied by a thorough flushing of the lubrication system may be all that is required.

Cylinder liners, pistons and connecting rods

15 The liner bores may be examined for wear either in or out of the engine block. The cylinder head must, of course, be removed in each case.

16 Examine the top of the cylinder, about a quarter of an inch below the top of the liner. Feel if there is any ridge running round the circumference of the bore. In a worn cylinder bore, a ridge will develop at the point where the top ring on the piston comes to the uppermost limit of its stroke. An excessive ridge indicates that the bore below the ridge is worn. If there is no ridge, it is reasonable to assume that the cylinder is not badly worn.

17 Measure the diameter of the cylinder bore, both in line with the piston gudgeon pin and at right angles to it, at the top and bottom of the cylinder. A cylinder is expected to wear at the sides where the thrust of the piston presses against it. In time this causes the cylinder to assume an oval shape. Furthermore, the top of the cylinder is likely to wear more than the bottom of the cylinder. It will be necessary to use a proper bore

measuring instrument in order to measure the differences in bore diameter across the cylinder, and variations between the top and bottom ends of the cylinder. As a general guide it may be assumed that any variation more than 0.25 mm indicates that the liners should be renewed. Provided all variations are less than 0.25 mm it is probable that the fitting of new piston rings will cure the problem of piston-to-cylinder bore clearances. If the cylinder bores are obviously deeply grooved or scored then the liners must be renewed, regardless of any measurement differences in the cylinder diameter. If new liners are to be fitted, new pistons will be required also, as they are supplied as matched sets.

18 With the pistons removed from the liners, carefully clean them and remove the old rings, keeping them in order and the correct way up. The ring grooves will have to be cleaned out, especially the top, which will contain a burnt carbon coating that may prevent the ring from seating correctly. A broken piston ring will assist in groove cleaning. Take care not to scratch the ring lands or piston surface in any way.

19 The top ring groove is likely to have worn the most. After the groove has been cleaned out, refit the top ring and any excessive wear will be obvious by a sloppy fit. The degree of wear may be checked by using a feeler blade.

20 Examine the piston surface and look for signs of any hairline cracks especially round the gudgeon pin area. Check that the oil drain holes below the oil control ring groove are clear, if not, carefully clean them out using a suitable size drill taking care not to mark the piston.

21 If any of the pistons are obviously badly worn or defective they must be renewed. A badly worn top ring land may be machined to accept a wider, stepped ring, the stop on the outer face of this type of ring being necessary to avoid fouling the unworn ridge at the top of the cylinder bore.

22 Providing the engine has not seized up or suffered any other severe damage, the connecting rods should not require any attention other than cleaning. If damage has occurred or the piston(s) shows signs of irregular wear it is advisable to have the connecting rod alignment checked. This requires the use of specialised tools and should therefore be entrusted to a Citroën agent or a competent automotive engineer, who will be able to check and realign any defective rods.

23 New Citroën rings are supplied with their gaps already preset, but if you intend to use other makes the gaps should be checked and adjusted if necessary. Before fitting the new rings on the pistons, each should be inserted approximately 75 mm down the cylinder bore and the gap measured with a feeler blade. The gap should be between 0.38 and 0.97 mm. It is essential that the gap should be measured at the bottom of the ring travel, as if it is

measured at the top of a worn bore and gives a perfect fit, it could easily seize at the bottom. If the ring gap is too small, rub down the ends of the ring with a very fine file until the gap, when fitted, is correct. To keep the rings square in the bore for measurement, line each up in turn by inserting an old piston in the bore upside down, and use the piston to push the ring down. Remove the piston and measure the piston ring gap.

Gudgeon pins

24 The gudgeon pins float in the piston and are an interference fit in the connecting rods. This interference fit between gudgeon pin and connecting rod means that heat is required (230 to 260°C/446 to 500°F) before a pin can be satisfactorily fitted in the connecting rod. If it is necessary to renew either the piston or connecting rod, we strongly recommend that the separation and assembly of the two be entrusted to someone with experience. Misapplied heat can ruin one, or all, of the components very easily.

25 Never re-use a piston if the original gudgeon pin has been removed from it.

Timing chain, sprocket and tensioner

26 Examine the teeth of both sprockets for wear. Each tooth on a sprocket is an inverted V-shape and wear is apparent when one side of the tooth becomes more concave in shape than the other. When badly worn, the teeth become hook-shaped and the sprockets must be renewed.

27 If the sprockets need to be renewed then the chain will have worn also and should also be renewed. If the sprockets are satisfactory, examine the chain and look for play between the links. When the chain is held out horizontally, it should not bend appreciably. Remember, a chain is only as strong as its weakest link and, being a relatively cheap item, it is worthwhile fitting a replacement anyway.

28 Check the condition of the tensioner slipper. If it is worn, renew it.

29 Inspect the oil pump drive gears for wear or damage and renew if necessary. Always fit a new timing cover oil seal (see illustration).



12.29 Renewing timing cover oil seal

Camshaft and rocker gear

30 The camshaft lobes should be examined for signs of flats or scoring or any other form of wear or damage. At the same time the rocker arms should also be examined, particularly on the faces where they bear against the camshaft, for signs of wear. Very slight wear may be removed by rubbing with an oilstone but maintain the original contour.

31 The camshaft bearing journals should be in good condition and show no signs of pitting or scoring as they are relatively free from stress.

32 If the bearing surfaces are scored or discoloured it is possible that the shaft is not running true. In this case it will have to be renewed. For an accurate check get your Citroën agent to inspect both the camshaft and cylinder head.

33 Worn camshaft bearings in the cylinder head can only be rectified by renewal of the head, an expensive business as the bearings are machined directly in the head.

34 The rocker arms can be removed from the shaft after extracting the circlip (distributor end) and the Allen screw from the opposite end (see illustrations).



12.34a Rocker shaft retaining circlip (arrowed)

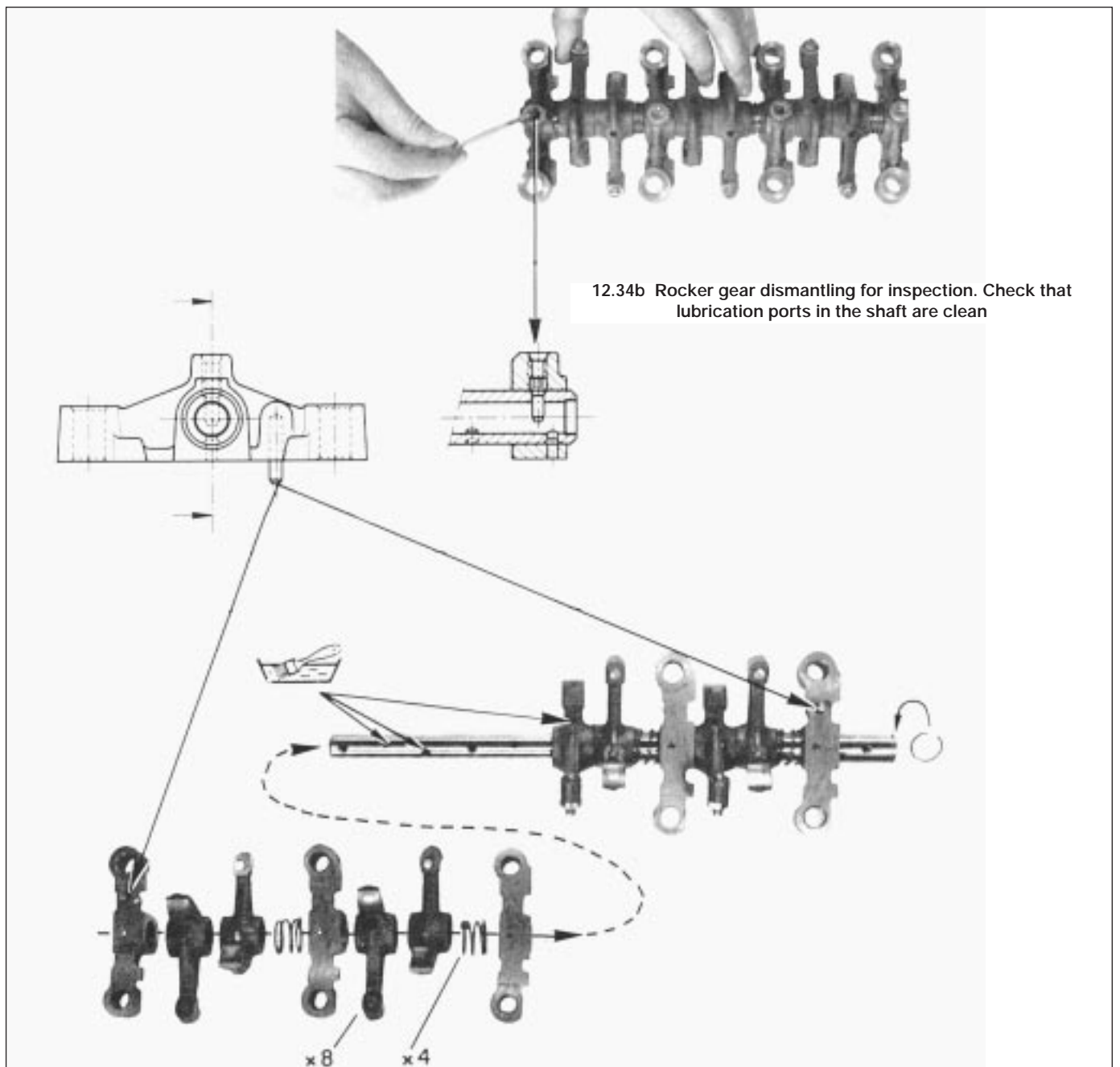

12.34b Rocker gear dismantling for inspection. Check that lubrication ports in the shaft are clean



12.41 Checking oil pump lobe tip clearance

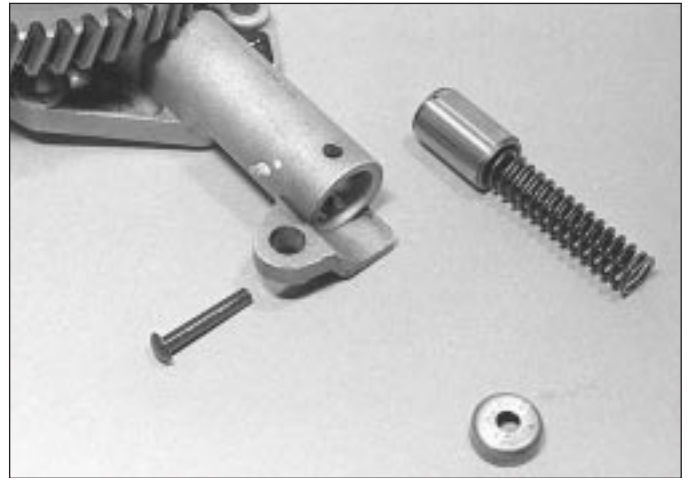

12.43 Oil pump relief valve components

35 When removing the various rocker components from the shaft, take careful note of the sequence in which they are removed. In particular note that the No 2 and No 4 rocker bearings are identical, keep the components in order as they are removed from the shaft for inspection.

36 Check the rocker shaft for signs of wear. Check it for straightness by rolling it on a flat surface. It is unlikely to be bent but if this is the case it must either be straightened or renewed. The shaft surface should be free of wear ridges caused by the rocker arms. Check the oil feed holes and clear them out if blocked or sludged-up.

37 Check each rocker arm for wear on an unworn part of the shaft. Check the end of the adjuster screw and the face of the rocker arm where it bears on the camshaft. Any signs of cracks or serious wear will necessitate renewal of the rocker arm.

Oil pump

38 The oil pump gears are exposed once the spacer plate is removed.

39 Side movement of the gear spindles will indicate wear in the bushes and the pump should be renewed complete.

40 Worn or chipped gear teeth must be rectified by renewal of the gear.

41 Check the clearance between the tip of the gear lobes and the oil pump body (see illustration).

42 If any of these clearances exceed the specified limit, renew the pump.

43 Remove the retaining pin from the relief valve housing and withdraw the cup, spring, guide and piston. Renew any worn components (see illustration).

Flywheel and starter ring gear

44 There are two areas in which the flywheel may have been worn or damaged.

45 The first is on the driving face where the clutch friction plate bears against it. Should the clutch plate have been permitted to wear down beyond the level of the rivets, it is

possible that the flywheel will have been scored. If this scoring is severe it may be necessary to have it refaced or even renewed.

46 Evidence of tiny cracks on the flywheel driving face will indicate that overheating has occurred.

47 The other part to examine is the teeth of the starter ring gear around the periphery of the flywheel. If several of the teeth are broken or missing, or the front edges of all teeth are obviously very badly chewed up, then it would be advisable to fit a new ring gear.

48 The old ring gear can be removed by cutting a slot with a hacksaw down between two of the teeth as far as possible, without cutting into the flywheel itself. Once the cut is made, a chisel will split the ring gear which can then be removed. To fit a new ring gear requires it to be heated first to a temperature of 220°C (435°F), no more. This is best done in a bath of oil or an oven, not with a naked flame. It is much more difficult to heat evenly and to the required temperature with a naked flame. Once the ring gear has attained the correct temperature it can be placed onto the flywheel. Make sure that the ring beds down properly onto the register. It should then be allowed to cool down naturally. If by mischance, the ring gear is overheated, it should not be used. The temper will have been lost, thereby softening it, and it will wear out in a very short space of time.

49 Although not actually fitted into the flywheel itself, there is a bush in the centre of the crankshaft flange onto which the flywheel fits. Whilst more associated with gearbox and clutch, it should always be inspected when the clutch is removed. The main bearing oil seal is revealed when the flywheel is removed. This can be prised out with a screwdriver but must always be renewed once removed. The spigot bush is best removed using a suitable extractor. Another method is to fill the recess with grease and then drive in a piece of close fitting steel bar. This should force the bush out. A new bush may be pressed in, together with a new seal. Make sure that the

chamfered end of the bush abuts the seal. The bush is self-lubricating.

Transfer gears

50 The condition of the transfer gears, their bearings and the input and output shafts, is obviously critical as they transmit the power of the engine to the transmission, and are liable to be a source of noise if worn. Check the transfer gears, as described in Chapter 6.

13 Cylinder head - dismantling, decarbonising, inspection and reassembly



Dismantling

1 Having removed the cylinder head, place it onto a clean workbench where it can be dismantled and examined. Unbolt the retaining plate (if necessary) and withdraw the camshaft (see illustrations).

2 Remove each valve and spring assembly using a valve spring compressor. Extract the split collets from between the spring retaining cup washer and valve stem (see illustration).

3 Progressively release the tension of the compressor until it can be removed, the spring and retainer withdrawn, and the valve extracted from the guide (see illustrations).



13.1a Remove camshaft retaining plate . . .

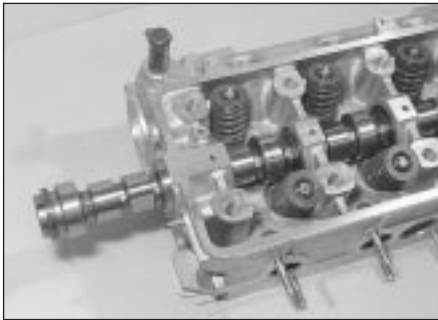

13.1b ... to allow camshaft withdrawal

4 As the valves are removed, keep them in order by inserting them in a card having suitable holes punched in it, numbered from 1 to 8. Discard the valve stem oil seals.

Decarbonising

5 Wash the cylinder head clean and carefully scrape away the carbon build-up in the combustion chambers and exhaust ports, using a scraper which will not damage the surfaces to be cleaned. If a rotary wire brush and drill is available this may be used for removing the carbon.

6 The valves may also be scraped and wire-brushed clean in a similar manner.

Inspection

7 With the cylinder head cleaned and dry, examine it for cracks or damage. In particular inspect the valve seat areas for signs of hairline cracks, pitting or burning. Check the head mating surfaces for distortion, the maximum permissible amount being 0.05 mm.

8 Minor surface wear and pitting of the valve seats can probably be removed when the valves are reground. More serious wear or damage should be shown to your Citroën dealer or a competent automotive engineer who will advise you on the action necessary.

9 Carefully inspect the valves, in particular the exhaust valves. Check the stems for distortion and signs of wear. The valve seat faces must be in reasonable condition and if they have covered a high mileage they will probably need to be refaced on a valve grinding machine. Again, this is a job for your Citroën dealer or local automotive machine shop.



13.2 Compress valve spring ...

10 Insert each valve into its respective guide and check for excessive side play. Worn valve guides allow oil to be drained past the inlet valve stem causing a smoky exhaust, while exhaust leakage through the exhaust valve guide can overheat the valve guide and cause sticking valves.

11 If the valve guides are to be renewed, this is a job best left to your Citroën agent who will have the required specialist equipment.

12 Assuming the valves and seats are in reasonable condition they should be resealed by grinding them using valve grinding carborundum paste. The grinding process must also be carried out when new valves are fitted.

13 The carborundum paste used for this job is normally supplied in a double-ended tin with coarse paste at one end and fine at the other. In addition, a suction tool for holding the valve head so that it may be rotated is also required. To grind in the valve, first smear a trace of the coarse paste onto the seat face and fit the suction grinder to the valve head. Then with a semi-rotary motion grind the valve head into its seat, lifting the valve occasionally to redistribute the grinding paste. When a dull matt continuous line is produced on both the valve seat and the valve then the paste can be wiped off. Apply a little fine paste and finish off the grinding process, then remove all traces of the paste.

14 The width of the line which is produced after grinding indicates the seat width. This width should not exceed 2 mm. If, after a moderate amount of grinding, it is apparent that the seating line is too wide, it probably means that the seat has already been cut back one or more times previously, or else the



13.3a ... and remove spring cup retainer, spring ...



13.3b ... and valve

valve has been ground several times. Here again, specialist advice is best sought.

15 Examine all the valve springs to make sure that they are in good condition and not distorted. If the engine has covered 30 000 miles (48 000 km) then fit new springs at reassembly. Renew the valve stem oil seals (see illustration).

16 At the same time, renew the valve spring seating washers which sit directly on the cylinder head (see illustration). These wear fairly quickly.

Reassembly

17 Before reassembling the valves and springs to the cylinder head make a final check that everything is thoroughly clean and free from grit (see illustration), then lightly smear all the valve stems with engine oil prior to reassembly. The camshaft can now be refitted in the cylinder head and located with the retaining plate. This is then secured with its bolt and a new shakeproof washer.



13.15 Valve stem oil seal



13.16 Valve spring seating washer

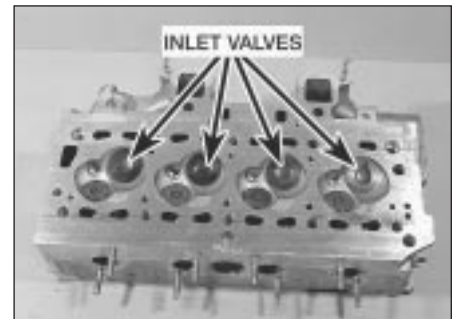

13.17 Cylinder head cleaned and reassembled

14 Engine reassembly - general information

It is during the process of engine reassembly that the job is either made a success or a failure. From the start there are certain basic rules to follow, these are as follows:

- Absolute cleanliness. The working area, the components of the engine and the hands of the person working on the engine must be completely free of grime and grit. One small piece of carborundum dust or swarf can ruin a bearing surface in no time.*
- Always use new gaskets, locking tabs, seals, lock nuts and any other parts mentioned in the Sections in this Chapter. It is pointless to dismantle an engine, spend considerable money and time on it and then waste all this for the sake of something as small as a failed oil seal.*
- Do not rush work. The most skilled and experienced mechanic can easily make a mistake if he is rushed.*
- Check that all nuts and bolts are clean and in good condition and ideally renew all spring washers, lockwashers and tab washers as a matter of course.*
- Obtain a supply of clean engine oil and clean cloths for reassembly.*
- A torque wrench is an essential requirement when reassembling the engine. This is because the various housings are manufactured from aluminium alloy. Whilst this gives the advantage of less weight, it also means that the various*

fastenings must be accurately tightened as specified to avoid distortion and/or damage to the components.

15 Engine - preparation for reassembly



1 Assuming that the engine has been completely stripped for reconditioning and that the block is now bare, before any reassembly takes place it must be thoroughly cleaned both inside and out.

2 Clean out the oilways using a bottle brush, wire or other suitable implement, and blow through with compressed air. Squirt some clean engine oil through to check that the oilways are clear.

3 If the core plugs are defective and show signs of weeping, they must be renewed at this stage. To remove, carefully drive a punch through the centre of the plug and use the punch to lever the plug out. Clean the aperture thoroughly and prior to fitting the new plug, smear the orifice with sealant. Use a small-headed hammer and carefully drive the new core plug into position with the convex side outwards. Check that it is correctly seated on completion.

4 As components are assembled, lubricate them with clean engine oil and use a suitable sealant where applicable.

5 Make sure that all blind tapped holes are clean, with any oil mopped out of them. This is because it is possible for a casting to fracture when a bolt is screwed in owing to hydraulic pressure.



16.4 One method of clamping cylinder liners

16 Cylinder liners - checking protrusion



1 Protrusion of the cylinder liners when assembled to the block must be within the prescribed limits so that a gastight seal can be achieved when the head is bolted on. One liner protruding too much or not enough will, despite the cylinder head gasket, make it impossible to secure a gas or watertight joint.

2 An O-ring seal is fitted between each liner mating flange and the cylinder block. These seals compress when the cylinder head is tightened down to effect a watertight seal.

3 Although the actual liner protrusion check method is the same, the procedure differs if the engine is assembled or dismantled.

4 If the cylinder head has been removed with the engine *in situ* the liners must be held under compression with the use of liner clamps (**see illustration**). Remove the dowels from the cylinder block top face to allow the clamps to be fitted, if necessary.

5 If the engine is dismantled, check that the seal mating surfaces of the liners and the cylinder block are clean then insert each liner into its respective position in the cylinder block without its seal.

6 Check each liner protrusion in turn, measuring the distance between the top face of the liner and the top face of the cylinder block. Use a dial test indicator if available but, failing this, use a metal rule and feeler blades to assess the protrusion (**see illustrations**).

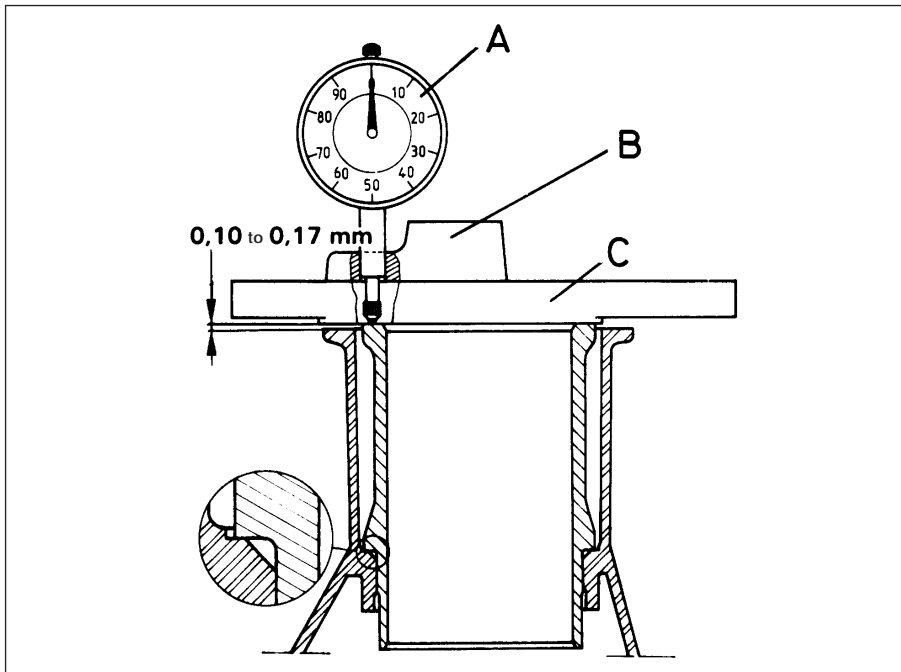

16.6a Cylinder liner protrusion check using a dial gauge

Gauge and mounting (A and B) and flat plate (C)



16.6b Measuring cylinder liner projection with a rule and feeler blades

7 As the protrusion of each liner in turn is checked, ensure that it is squarely located in the cylinder block. The protrusion of each liner should be within the limits specified.

8 Finally check the difference in height between adjacent liners. Use the dial test indicators or rule and feeler blades to measure the difference in height, if any, between adjacent liners at a point on each lying along the centre axis parallel with the crankshaft on the top face. Each difference in level must not exceed the maximum specified.

9 If the checks reveal a discrepancy on an installed engine then it will be necessary to renew the liner O-rings or even one or more liners. In either case the engine/transmission will have to be removed for dismantling.

10 Once the checks have shown the liners to be within limits of protrusion and squareness, reassembly can continue or, if appropriate, temporary retainer clamps/straps should be fitted to hold them in position. Do not turn the crankshaft if the liners are not restrained from movement. Cover the exposed engine internal parts if there is likely to be a delay before completing reassembly.

11 With new liners, once correctly located, mark their sequence in the block and withdraw them so that their piston/rods can be fitted - (see illustration 11.18).

17 Engine - complete reassembly



Pistons and liners

1 Fit the piston rings to the pistons. Always fit the rings from the piston crown end. Use three old feeler blades equally spaced behind the ring so that it will slide down to the lower grooves without dropping into the higher ones (see illustration).

2 Make sure that the rings are correctly located and the right way up (see illustration).

3 Twist the piston rings so that the gap in the oil control ring expander aligns with the gudgeon pin and the gaps in the rails are offset from the gudgeon pin by between 20.0 and 50.0 mm. The caps in the top two compression rings should be equally spaced



17.1 Method of fitting piston rings

(120°) from the gap in the oil control expander around the piston.

4 If new piston/liner assemblies have been supplied, the identification marks on the piston and liner (see illustration) should be as follows:

Piston	Liner
A	One file mark on rim
B	Two file marks on rim
C	Three file marks on rim

5 All four pistons should be of the same grading.

6 Fit the liners to the piston/connecting rod assemblies so that when installed in the cylinder block, the rim mark on the liner will be towards the oil gallery side and the arrow on the piston crown facing towards the timing chain cover end of the engine (see illustration). Piston-to-rod relationship is not important.

7 Oil the piston rings liberally and fit a compressor to the piston and compress the rings fully. When fitted, the top edge of the ring compressor should be 4 to 5 mm below the crown of the piston.

8 Lubricate the bore of the liner and insert the piston. As this is done, the compressor will be pushed off (see illustration).

9 Push the liner down so that the piston crown is level with or just below the top edge of the liner.

10 With the pistons and liners reassembled, fit a new O-ring seal over the bottom end of each liner in turn, ensuring that the seals are not twisted as they are fitted (see illustration).

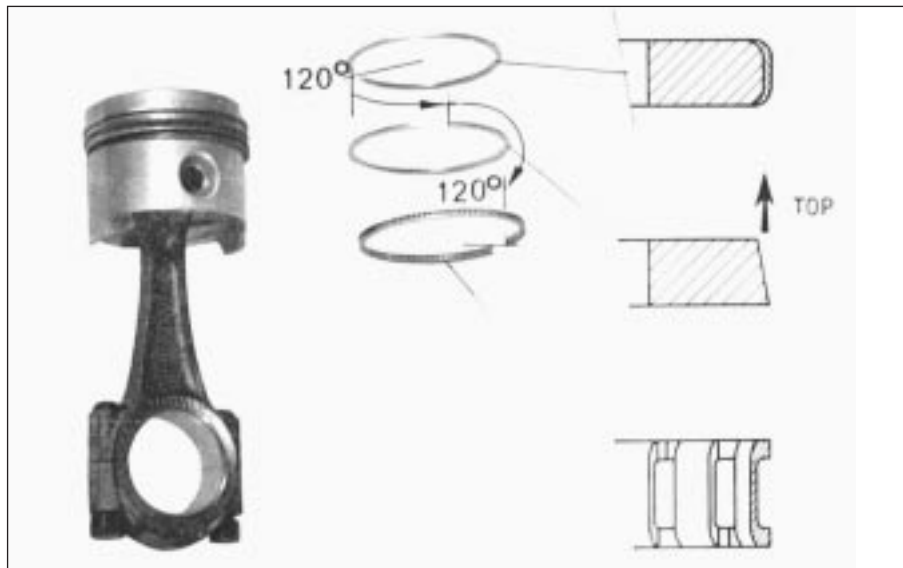

17.2 Piston rings showing correct orientation



17.4 Piston/liner grading mark



17.6 Piston crown showing directional arrow



17.8 Fitting the piston/rod assembly to its cylinder liner



17.10 Cylinder liner O-ring seal



17.12 Installing piston/liner assembly

11 Remove the big-end caps, wipe the recesses in rod and cap absolutely clean and fit the bearing shells. If the original shells are being used again, make sure that they are being returned to their original locations.

12 Push the liner/rod assemblies into the block, without disturbing the seals and aligning the location marks (see illustration).

13 Fit clamps to hold the liners in the block.

Crankshaft

14 Place the block so that it rests on its top face, wipe out the recesses and fit the main

bearing shells. Note that on engines manufactured after December 1985, the main bearing shell location tags in the crankcase upper and lower half-sections have been modified. If renewing the bearing shells, ensure that the correct type is fitted (see illustrations).

15 Fit the semi-circular thrustwashers which control crankshaft endfloat. The oil grooves of the thrustwashers must be against the machined face of the crankshaft (see illustration).

16 Oil the shell bearings and lower the

crankshaft into position (see illustration).

17 Now check the crankshaft endfloat. Do this by first pushing the crankshaft fully in one direction and then in the other. A dial gauge or feeler blades should be used to measure the endfloat (see illustration). If the endfloat is not within the specified limits, change the thrustwashers and fit alternatives of suitable thickness. Thrustwashers are available in a choice of four thicknesses.

18 Lubricate and fit the big-end caps, complete with bearing shells. Make sure that the cap/rod matching marks are in alignment. This will ensure that both tongues of the shells are on the same side (see illustration).

19 Tighten the big-end nuts to the specified torque.

Crankcase housing

20 Check that the three location dowels are in position in the cylinder block flange face and fit a new O-ring seal to each (see illustration).

21 Clean the recesses in the remaining crankcase housing section and fit the main bearing shells. Note that the grooved shells are located in positions 2 and 4. Lubricate the main bearing shells with clean engine oil.

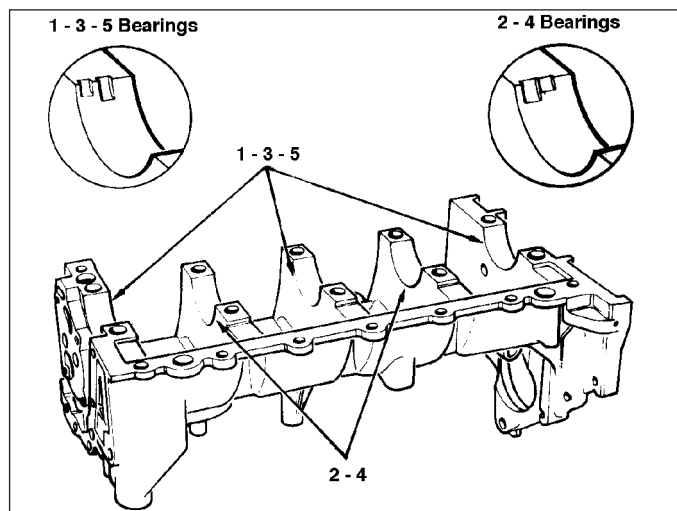

17.14a Main bearing shell location tags - crankcase lower half shown (post December 1985)

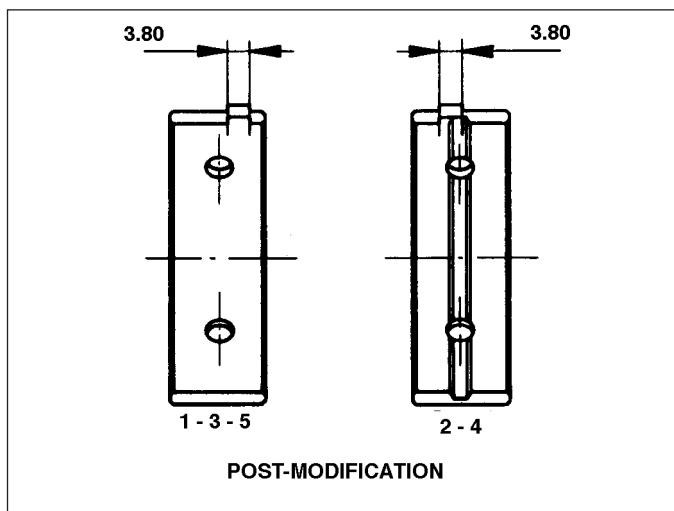

17.14b Main bearing shell identification - post December 1985



17.15 Crankshaft thrustwashers

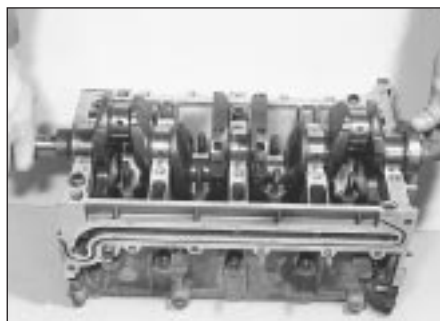

17.16 Lowering crankshaft into position



17.17 Checking crankshaft endfloat



17.18 Fitting a big-end cap



17.20 Crankcase flange O-ring seal in position on dowel

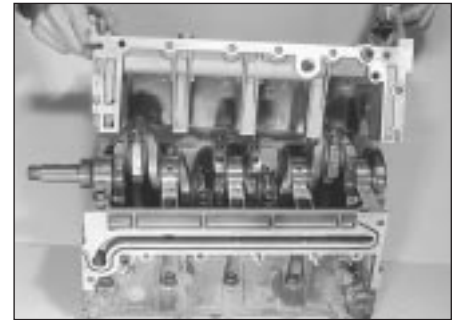

17.23 Fitting crankcase housing

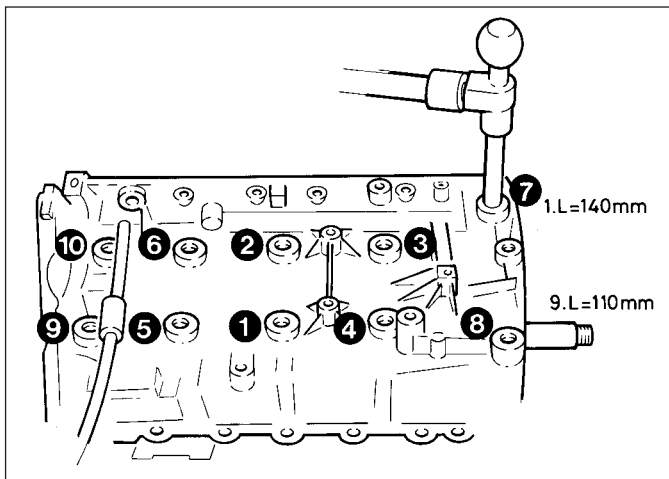

17.25 Main bearing/casing bolt tightening sequence

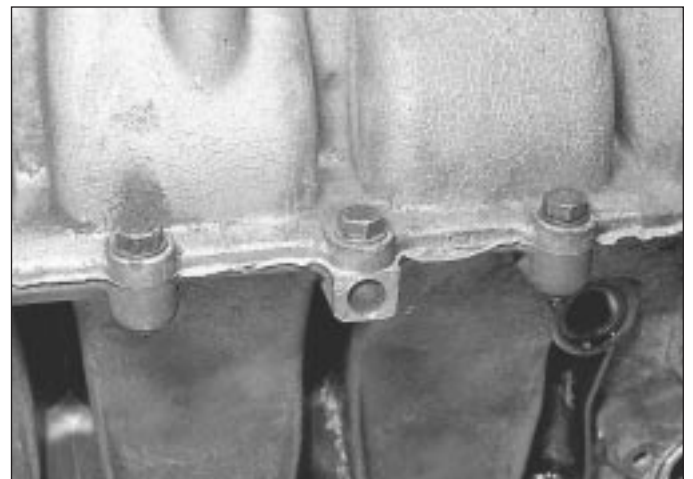

17.26 Crankcase housing flange bolts

22 Apply an even layer of jointing compound to the mating flange of the crankcase.

23 Locate the crankcase housing, taking care not to displace the bearing shells (see illustration).

24 Lubricate the bolt threads then screw in the ten main bearing/casing bolts with flat washers. Note that the two longer bolts are at the flywheel housing end and the very long one at the crankshaft pulley end on the oil pump side.

25 Tighten the bolts in the sequence given in two stages to the specified torque (see illustration).

26 Now screw in and tighten the seven

housing flange bolts with their spring washers (see illustration).

27 Grease the lips of a new crankshaft oil seal and drive it squarely into position (see illustration).

Cylinder head

28 Refit the cylinder head, referring to the appropriate Section of this Chapter.

Timing chain and sprockets

29 Fit the timing chain tensioner oil filter and the crankshaft sprocket Woodruff key. Bolt the chain tensioner into position (see illustrations).

30 Rotate the crankshaft by temporarily screwing in two flywheel bolts and placing a bar between them until the key is in alignment with the crankcase joint.

31 Temporarily fit the camshaft sprocket and rotate the camshaft until the keyway is positioned as shown (see illustration).

32 Fit the crankshaft sprocket (see illustration).

33 Loop the chain around the crankshaft sprocket so that the bright link on the chain is centred on the timing mark on the sprocket (see illustration).

34 Now loop the chain around the camshaft sprocket so that the two bright links are



17.27 Fitting new crankshaft oil seal



17.29a Locate chain tensioner filter . . .



17.29b . . . then fit tensioner

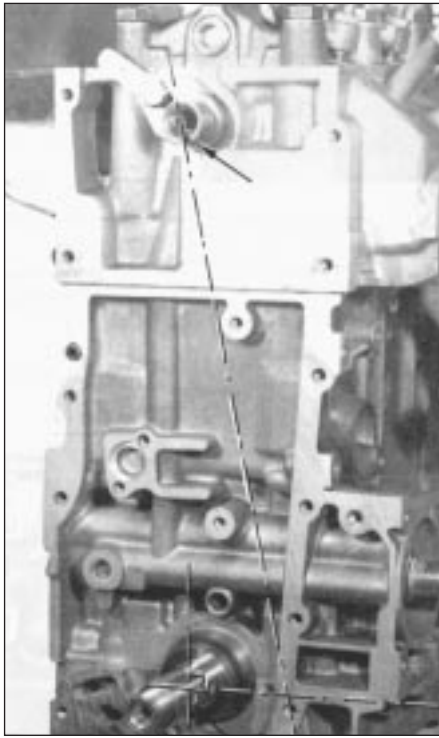

17.31 Align camshaft and crankshaft sprocket Woodruff key slots as shown



17.32 Locate crankshaft sprocket



17.33 Timing chain bright link at crankshaft sprocket



17.34 Timing chain bright links at camshaft sprocket timing mark

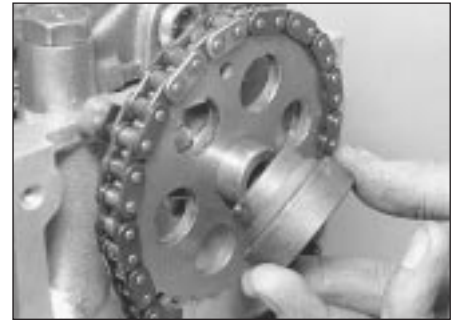

17.35a Fuel pump eccentric

positioned one on each side of the sprocket timing mark. Push the sprocket with chain onto the camshaft, if necessary move the camshaft a fraction to align the keyway (see illustration).

35 Screw in the camshaft sprocket bolt with fuel pump eccentric and tighten to the specified torque (see illustrations).

36 Where the first type chain tensioner is fitted, check that the tensioner shoe is locked in the retracted position and assemble the two retaining bolts and locking washers, the joint gasket and the spacer plate to the tensioner. Fit the tensioner to the block and tighten the

two bolts to their specified torque. Arm the tensioner by turning the lock ratchet in a clockwise direction and allow the tensioner to automatically take up the chain tension. Do not assist the action of the tensioner (see illustration).

37 Where the second type of chain tensioner is fitted, fit the tensioner into position on the block and tighten the retaining bolts. Arm the tensioner by engaging the spring and prising it upwards (see illustration).

38 Refit the timing chain guide plate and tighten the two retaining bolts to the specified torque.

Oil pump

39 Check that the locating dowel is in position and fit the oil pump with spacer plate (no gasket is used). If the pump driven sprocket is hard to turn, release the pump



17.35b Tightening sprocket retaining bolt



17.36 Releasing timing chain tensioner - first type

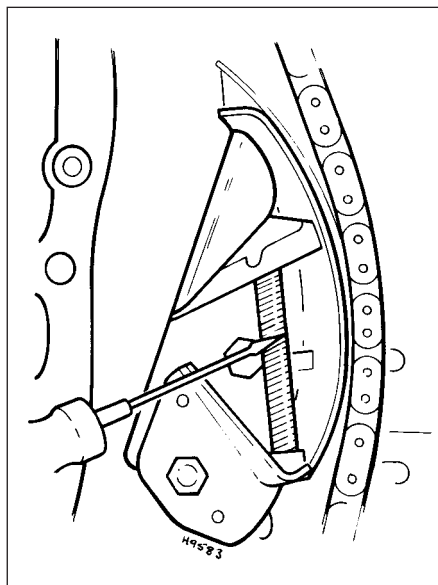

17.37 Arming timing chain tensioner - second type



17.39 Fitting oil pump with spacer plate

mounting bolts and turn the pump slightly on its locating dowel. Re-tighten the bolts (see illustration).

40 Fit the oil pump drive sprocket and Woodruff key to the crankshaft (see illustration).

General

41 The engine is now ready for reconnection to the transmission. If required, certain engine ancillary items such as the oil filter, oil pressure sender and coolant pump can be fitted into position before reconnecting the engine to the transmission (see illustration).



17.40 Oil pump drive sprocket



17.41 Oil pressure sender switch

18 Engine - reconnection to transmission



1 Check that the oil pick-up strainer is in position within the transmission casing.

2 Fit the sump cover using a new gasket.

3 Tighten the fixing bolts and drain plug to the specified torque.

4 Fit the cover plate.

5 Apply jointing compound to the mating surfaces of the engine and transmission. Ensure that an even layer of sealant is applied around the oil duct.

6 On the transmission, locate a new O-ring seal and check that the locating dowels and the studs are in position (see illustration).

7 Offer the transmission to the engine, screw in the connecting bolts and nuts and tighten to the specified torque (see illustration).



18.6 O-ring seal on transmission casing

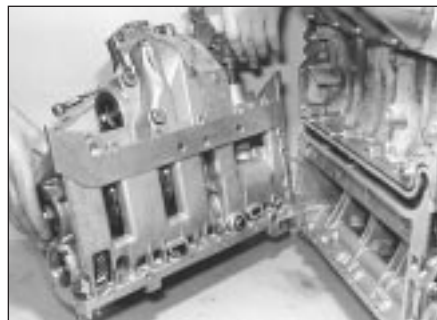

18.7 Offering transmission to engine



18.8a Refitting timing cover with new gasket



18.8b Timing cover bolt nearest coolant pump pulley

8 The timing cover can now be fitted (see illustration). The new timing cover gasket must be fitted dry and, prior to fitting the cover, check that the centring pin is in position and put the bolt nearest the coolant pump pulley into its cover hole, otherwise the pulley will prevent it from being fitted later (see illustration). Do not tighten the cover bolts yet.

9 Fit the coolant hose retainer under its cover bolts.

10 Use the crankshaft pulley to centralise the timing chain cover and then tighten the cover bolts to the specified torque.

11 Cut off the upper ends of the cover gasket flush. Lubricate the lips of the crankshaft pulley oil seal and locate it onto the crankshaft and into the timing cover. Drive the seal carefully into position using a suitable tube drift or mandrel.

12 Locate the Woodruff key into its groove in the crankshaft, refit the pulley and tighten the retaining nut to the specified torque. When tightening the pulley retaining nut, fit two bolts into the flywheel flange end of the crankshaft and jam a lever between them to prevent the crankshaft from turning. The nut threads should be treated with a suitable locking sealant prior to fitting.

13 Fit the alternator drivebelt pulley into position on the front end of the coolant pump drivebelt pulley and secure with the three bolts.

14 Fit the flywheel. Apply thread locking fluid to clean threads and screw in the flywheel bolts to the specified torque. The flywheel holes are offset so it will only go onto the crankshaft flange in one position (see illustration).

15 Fit the clutch and centralise the friction plate.

16 Fit a new gasket and the flywheel housing complete with transfer gears. Make sure that the engine lifting lug and earth strap are correctly located under their respective bolts.

17 If they were removed, bolt the engine mountings to the flywheel housing.

18 Fit the starter motor. Tighten the bolts and nuts in the following order:

- a) Starter drive end flange to flywheel housing
- b) Brush end bracket to engine crankcase
- c) Brush end bracket to starter motor

19 Adjust the valve clearances and using a new gasket, fit the rocker cover.



18.14 Tightening flywheel bolts to specified torque

20 Refit the alternator and the remaining engine ancillary items still to be fitted, reversing the removal sequence for the various items and referring to the relevant Chapter for full fitting details.

19 Engine - initial start-up after overhaul



- 1** Make sure that the battery is fully charged and properly reconnected.
- 2** Replenish the coolant and all lubricants.
- 3** Top-up the hydraulic system and prime the high pressure (HP) pump.
- 4** It will require several revolutions of the engine on the starter motor to pump fuel to the carburettor. As soon as the engine fires and runs, keep it going at a fast tickover and

bring it up to the normal working temperature.

5 With the engine running, repressurise the hydraulic system.

6 As the engine warms up there will be odd smells and some smoke from parts getting hot and burning off oil deposits. The signs to look for are leaks of coolant or oil which will be obvious if serious.

7 Check the exhaust pipe and manifold connections. These do not always find their exact gas-tight position until the warmth and vibration have acted on them and it is almost certain that they will need tightening further. This should be done with the engine stopped.

8 When normal running temperature has been reached, adjust the engine idling speed. Run the engine until the cooling fan cuts in and then switch off.

9 Allow at least two hours for the engine to cool down and then retighten the cylinder

head bolts after removing the rocker cover. Follow the bolt tightening sequence and, starting with the first, slacken the bolt and retighten it to the specified final tightening torque before loosening the second bolt. Repeat until all bolts have been retightened.

10 Check and adjust the valve clearances.

11 Check the ignition timing.

12 Road test the car to check that the timing is correct and that the engine is giving the necessary smoothness and power. Do not race the engine. If new bearings and/or pistons have been fitted, it should be treated as a new engine and run in at a reduced speed.

13 Change the engine oil at 1000 miles (1600 km) if many of the engine internal components have been renewed. At the same mileage, check the tension of the drivebelt.