

Multi Chip White LED Modules

Features and Benefits

- High efficiency, 100 lm/W (20 mA) with all LEDs illuminated; equivalent to fluorescent lamps (HCFL)
- Low thermal resistance, $R_{\theta JC} = 6^{\circ}\text{C/W}$
- High optical, 50 lm, output with all LEDs illuminated
- Superior directivity
- 5.23 mm \times 13.7 mm case footprint, and low 2.5 mm overall package height
- Silver plating on leadframe
- 8 LED configuration

Package:

16-pin, 1.27 mm pitch, surface mount

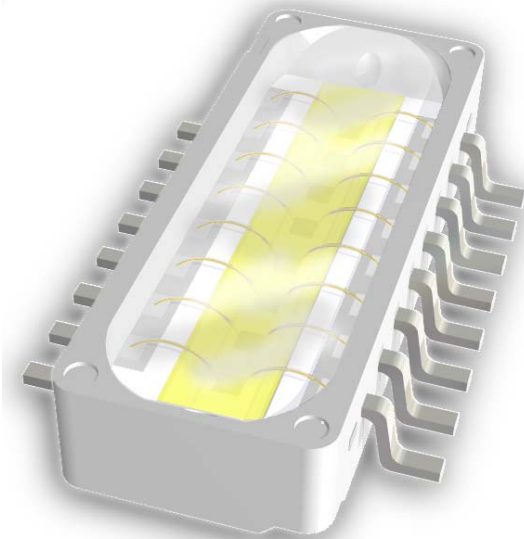

Not to scale

Description

The SEPW series of LEDs provides a range of high-powered InGaN blue LEDs producing brilliant white light that can be used in general lighting applications, amusement and gaming equipment, and for backlighting TFT displays. Each module combines 8 LEDs in 2 separate channels.

Modular design allows the SEPW devices to be easily assembled into string arrays by simply connecting the modules in series. The devices also provide superior color balance throughout the display because of the high density of LEDs that can be achieved. This also minimizes the distance that power and control lines must run between LEDs and from the LEDs to the control electronics.

The white thermoplastic case is an innovative SanKen original design with exceptional heat dissipation properties. The white resin compound is especially formulated for superior reflectance and transmittance of the generated light. Enhanced thermal dissipation is achieved through the incorporated heatsink on the bottom of the package. The heatsink can be mated directly to an external radiator through the PCB for superior heat conduction allowing dense placement of modules.

The leadframe is plated with silver, providing a highly-reflective surface for the bottom and sides of the emitting area. The terminals and heatsink are also silver-plated.

Typical Application

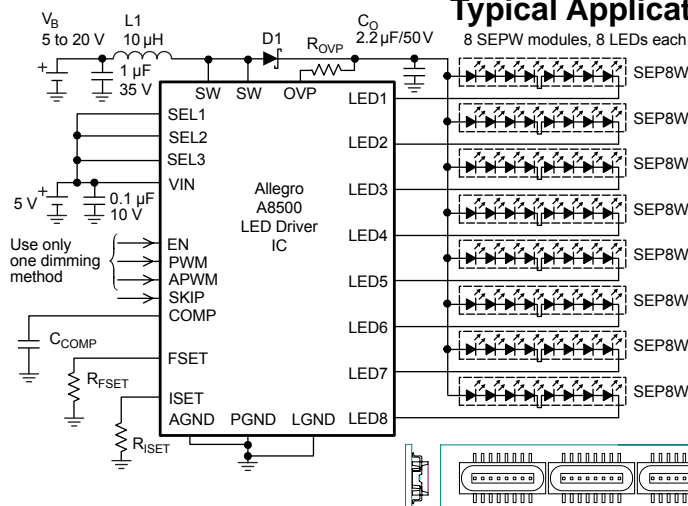

The SEPW devices can be mounted in tight arrays on a single PCB substrate for ease of manufacture and to provide a dense, uniform appearance when illuminated.

The application shown here uses eight SEP8Wx2001 LED modules, each populated by eight LEDs connected in series.

R_{OVP}	100 k Ω
C_{COMP}	0.1 μF / 6.3 V
R_{ISET}	12.7 k Ω (for 20.3 mA)
R_{FSET}	26.1 k Ω (for 1 MHz switching frequency)

Selection Guide

Part Number	LEDs	Channels	Color Temperature	Internal Circuit Diagram (Pin Numbers Shown)	Packing
SEP8WL2001	8	2	Bulb Light (2900)		1000 pieces per reel
SEP8WN2001	8	2	Day White (5000)		

Absolute Maximum Ratings (electrical characteristics at $T_A=25^\circ\text{C}$)

Characteristic	Symbol	Notes	Rating	Units
Forward Current (Continuous)	I_f	Per element	40	mA
Forward Current (Pulsed)	I_{fp}	Frequency, $f = 1 \text{ kHz}$, pulse width, $t_w = 100 \mu\text{s}$	100	mA
Reverse Voltage	V_R		5	V
Isolation Voltage	V_{is}	Measured from device pins to heatsink, with DC voltage applied	± 60	V
Operating Temperature	T_{opr}		-40 to 85	$^\circ\text{C}$
Storage Temperature	T_{stg}		-40 to 90	$^\circ\text{C}$

Operating Characteristics

Characteristic	Symbol	Conditions		Min.	Typ.	Max.	Units
Electrical							
Forward Voltage (per LED element)	V_f	$I_f = 20 \text{ mA}$, $T_A = 25^\circ\text{C}$		2.6	3.1	3.8	V
Reverse Current (per LED channel)	I_R	$V_R = 5 \text{ V}$		-	-	10	μA
Optical							
Luminous Flux (all channels)	Φ	SEP8Wx	8 LEDs, $I_f = 20 \text{ mA / LED}$	25	40	-	lm
Peak Wavelength	λ_P		$I_f = 20 \text{ mA}$, $T_A = 25^\circ\text{C}$	-	460	-	nm
Thermal							
Thermal Resistance (junction to exposed thermal pad)	$R_{\theta JC}$	SEP8Wx	8 LEDs	-	6	-	$^\circ\text{C/W}$
Thermal Resistance (junction to ambient)	$R_{\theta JA}$	All SEPxWx		-	120	-	$^\circ\text{C/W}$

All performance characteristics given are typical values for circuit or system baseline design only and are at the nominal operating voltage and an ambient temperature, T_A , of 25°C , unless otherwise stated.

Chromaticity and Color Temperature (JIS Z9112-2004) at $T_A = 25^\circ\text{C}$, $I_F = 20\text{ mA}$

Color	Symbol	JIS Compliant	x (± 0.01)	y (± 0.01)	Color Temperature (Center) (K)
Day White	WN	Yes	0.3616	0.3875	4600 to 5500 (5000)
			0.3552	0.3476	
			0.3324	0.3296	
			0.3326	0.3635	
Bulb Light	WL	Yes	0.4834	0.4382	2600 to 3250 (2900)
			0.4594	0.3971	
			0.4153	0.3862	
			0.4305	0.4218	

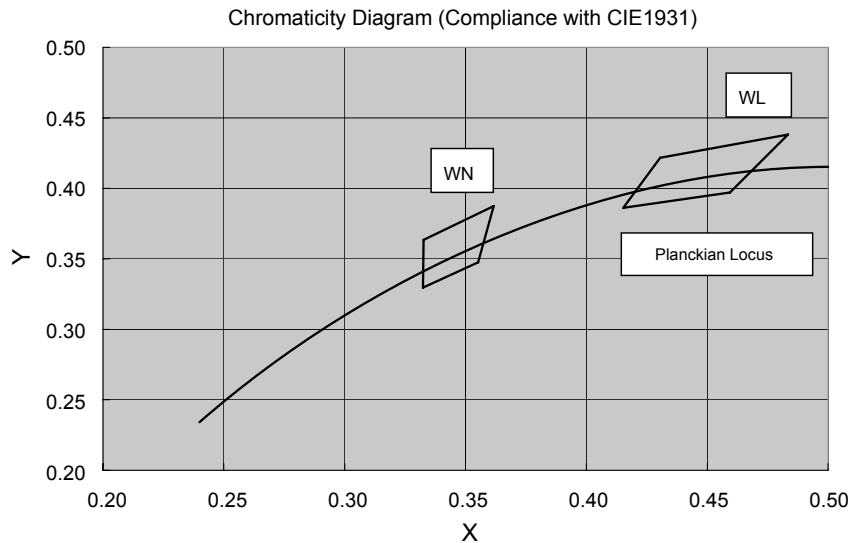

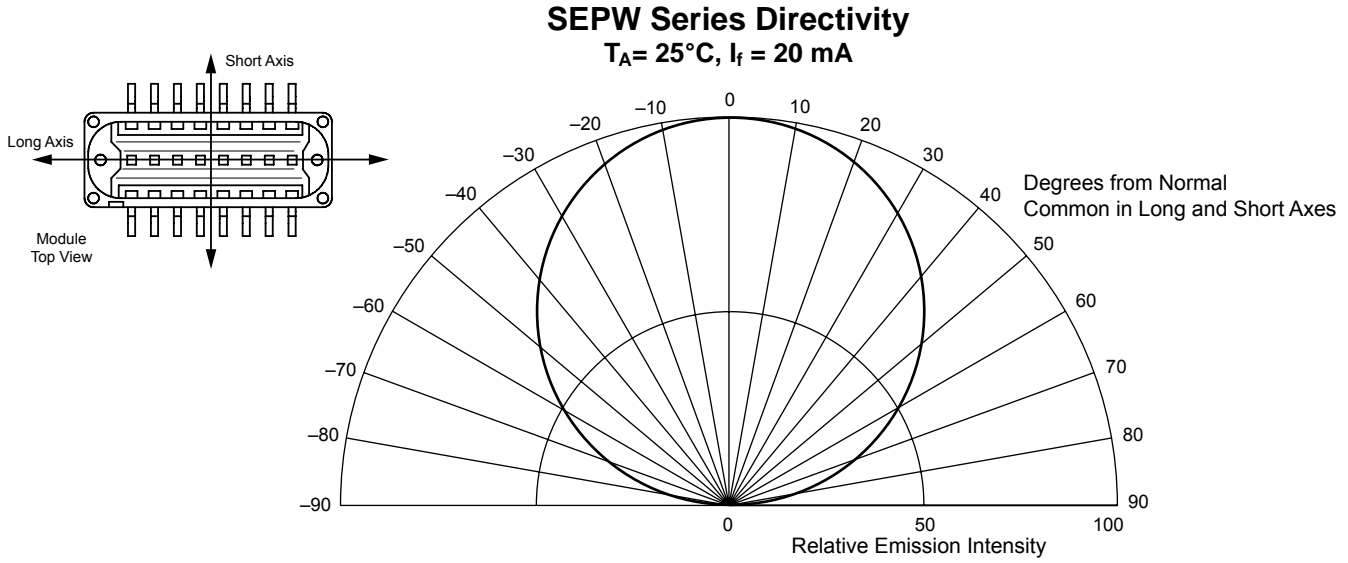

Emission Color Mixing

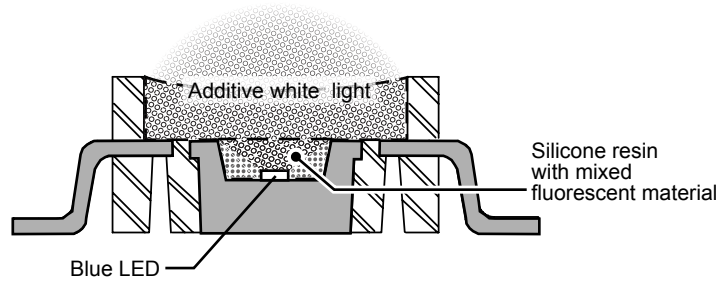

Emission Spectrum (Typical)

$T_A = 25^\circ\text{C}$, $I_f = 20\text{ mA}$

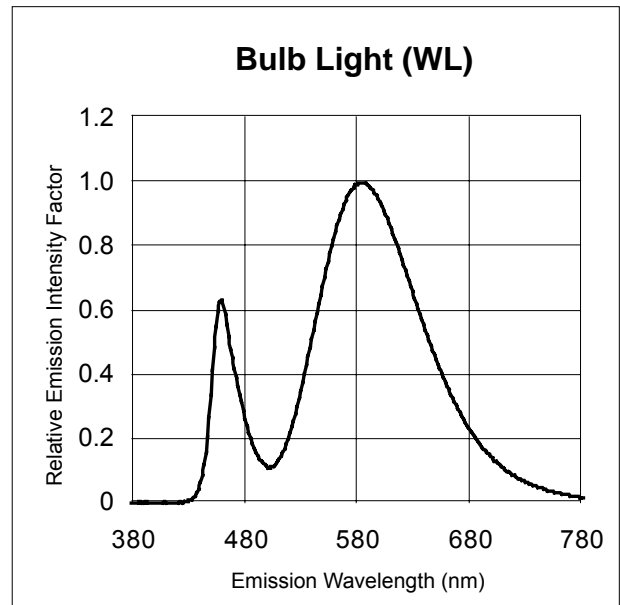
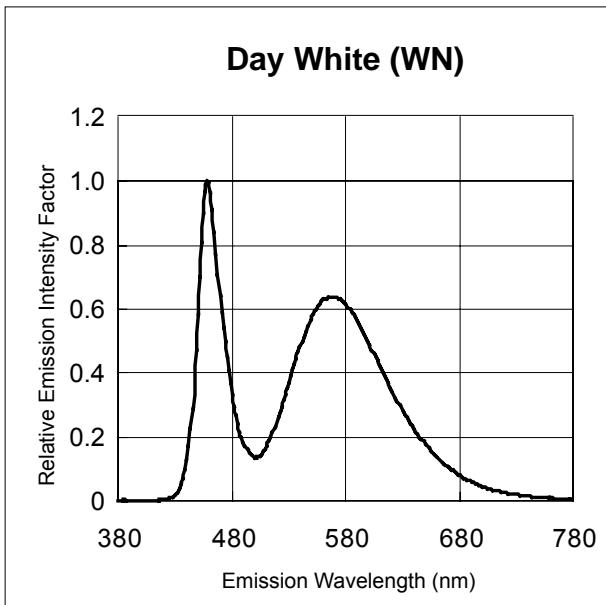

Forward Current versus Forward Voltage
 $T_A = 25^\circ\text{C}$

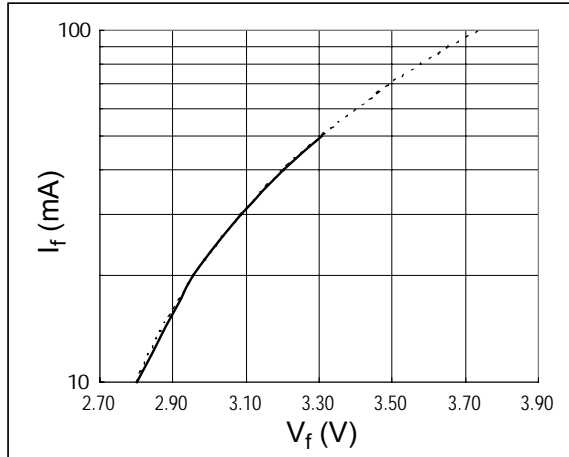

Relative Luminous Flux versus Forward Current, $T_A = 25^\circ\text{C}$

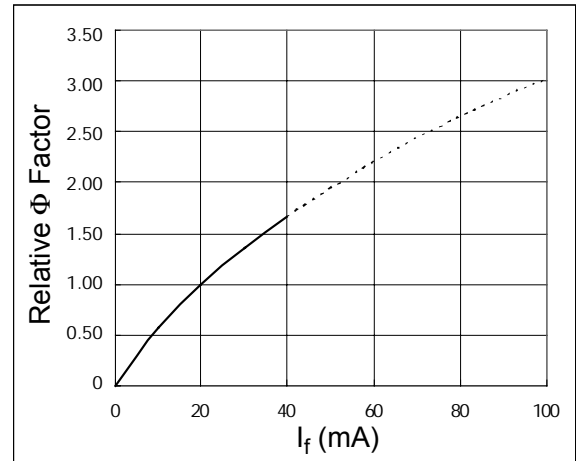

Forward Voltage versus Ambient Temperature
 $I_f = 20\text{ mA}$

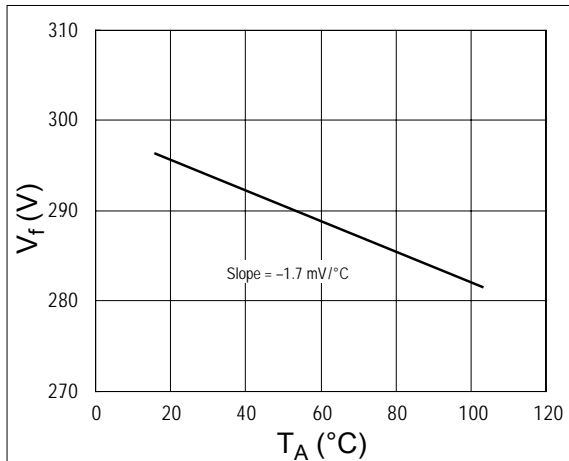

Relative Luminous Flux versus Ambient Temperature, $I_f = 20\text{ mA}$

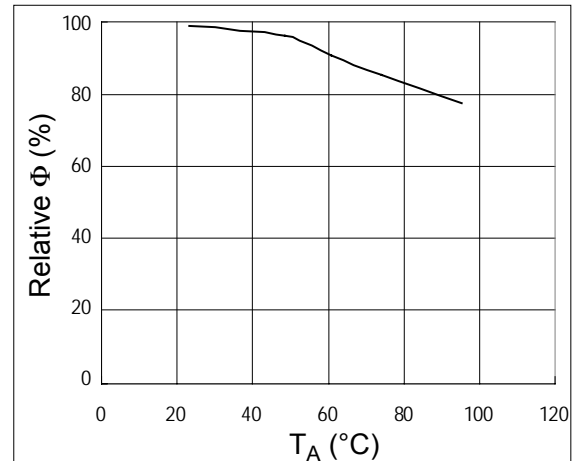

Forward Current versus Duty Cycle
 $T_A = 25^\circ\text{C}$, $t_w \leq 100\ \mu\text{s}$

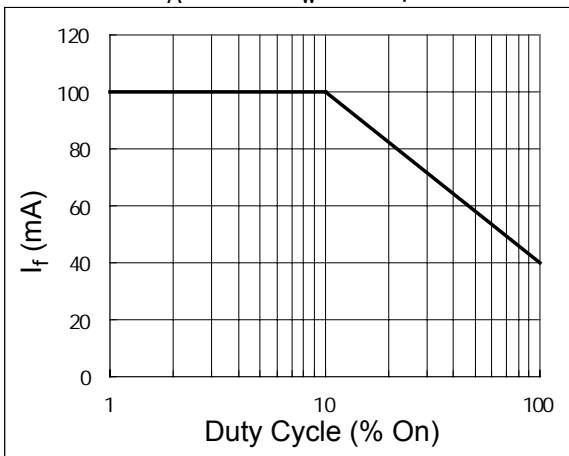

Allowable Forward Voltage versus Ambient Temperature at Various Thermal Resistances

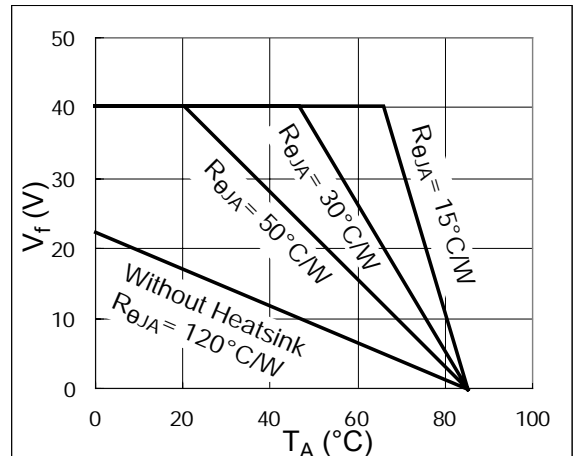

Chromaticity versus Forward Current (Typical)

$T_A = 25^\circ\text{C}$

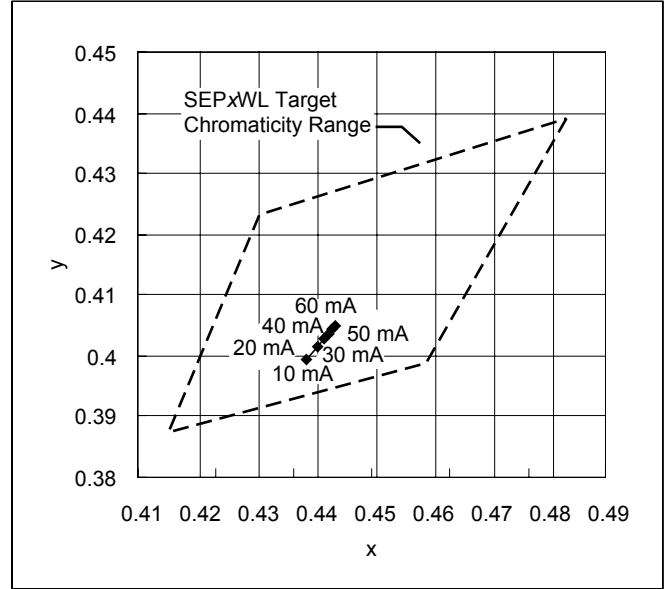
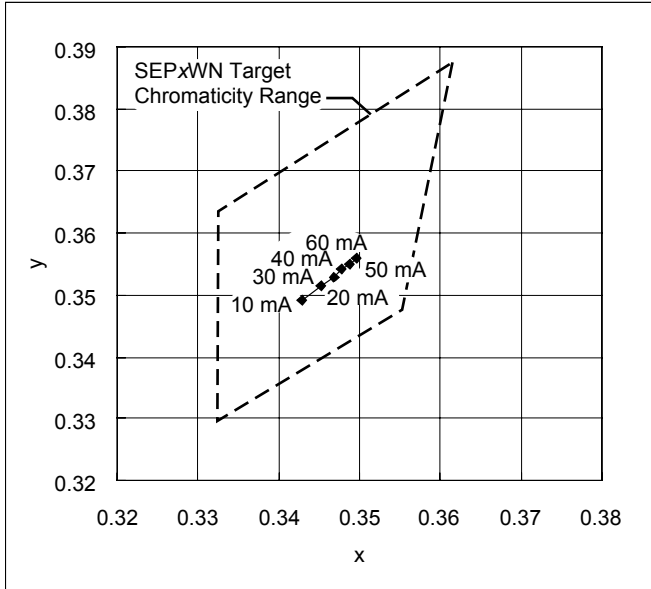

Chromaticity versus Ambient Temperature

$I_f = 20\text{ mA}$

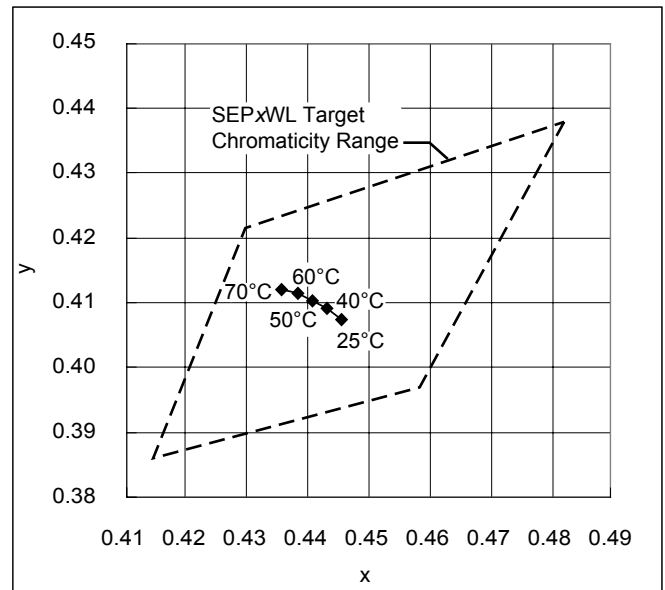
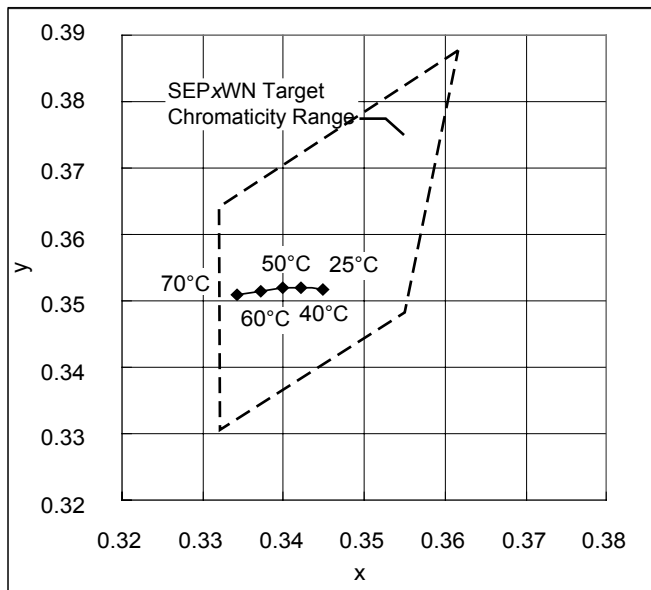

Package Outline Drawing

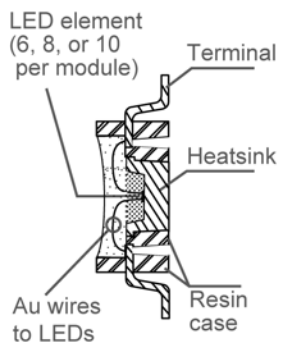

Section A-A

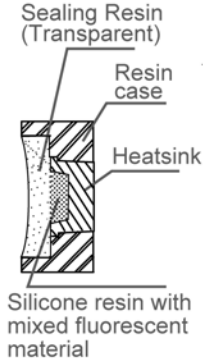

Section B-B

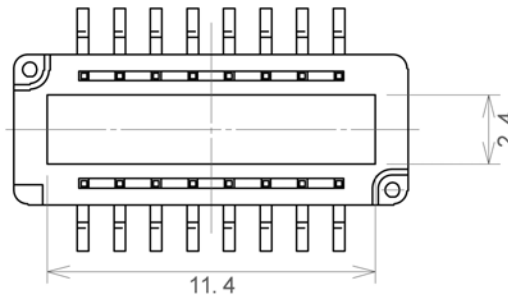
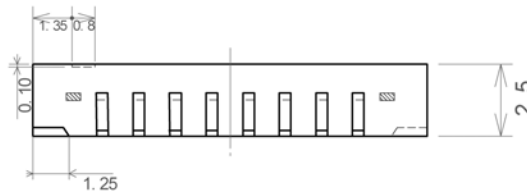
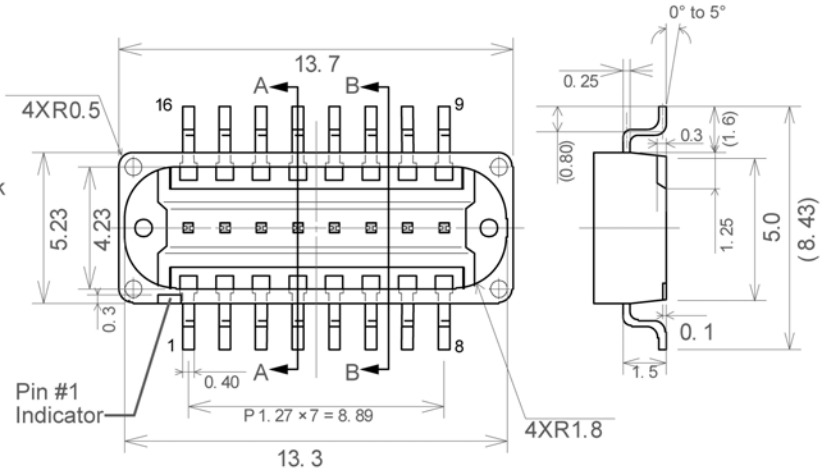

Terminal core material: Cu
 Terminal treatment: Ag plating
 Heatsink core material: Cu
 Heatsink treatment: Ag plating

Dimensions in millimeters

Package labeling codes (exact appearance at manufacturer discretion):

1st line, type: SEP[A][BB][C][D][EE]
 Where: A is the quantity of LEDs in the module
 BB is the color temperature code
 C is the number of channels
 D is the package code, and
 EE is the device design code

2nd line, lot: YMDD
 Where: Y is the last digit of the year of manufacture
 M is the month (1 to 9, O, N, D)
 DD is the date

3rd line, quantity of units in the container



Device is lead (Pb) free.

Solder Pad Layout

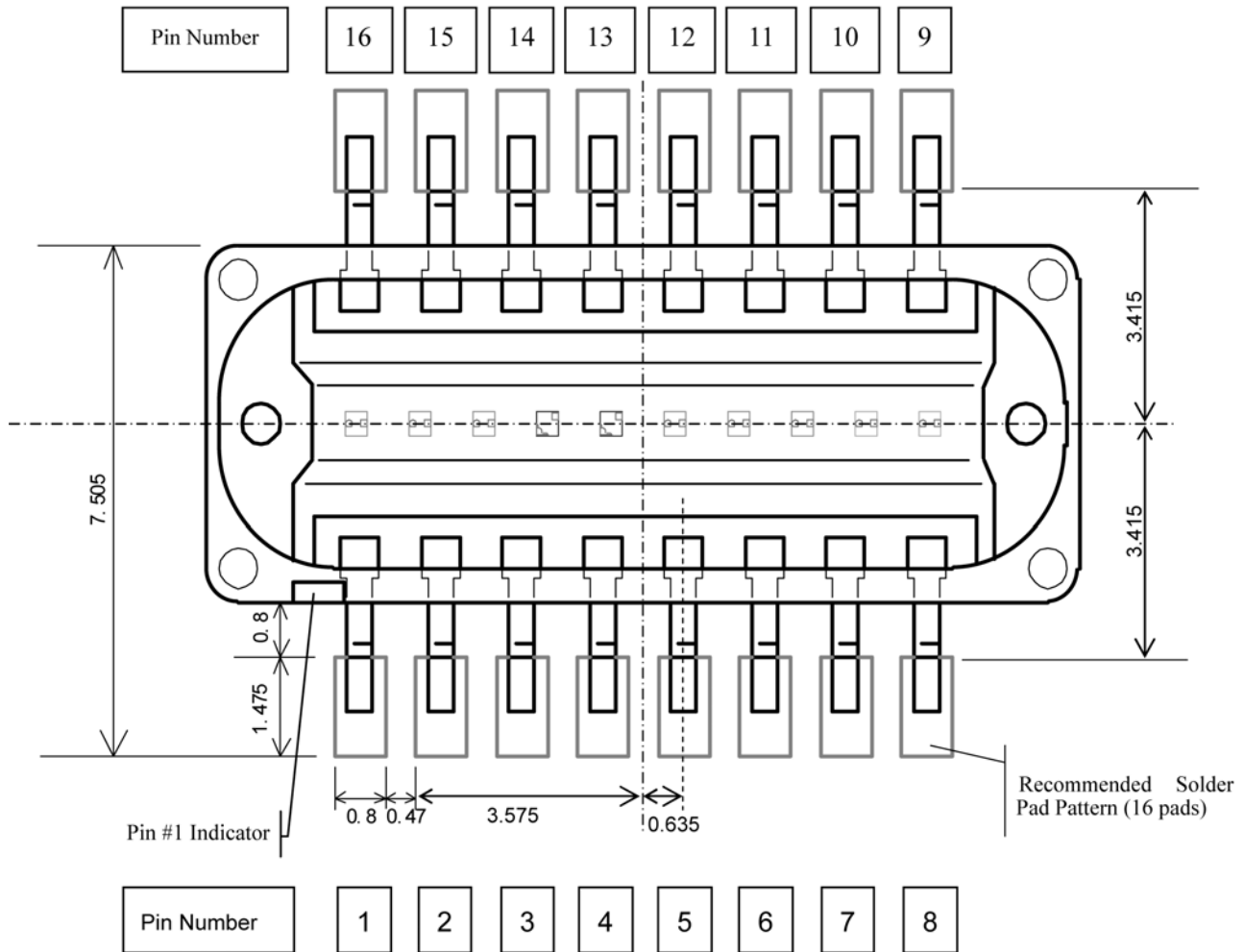

If the device is installed connected to an external radiator, please coat heatsink area with thermal conduction material such as thermal conductive adhesive or thermal conductive grease.

Embossed Tape and Reel Specification

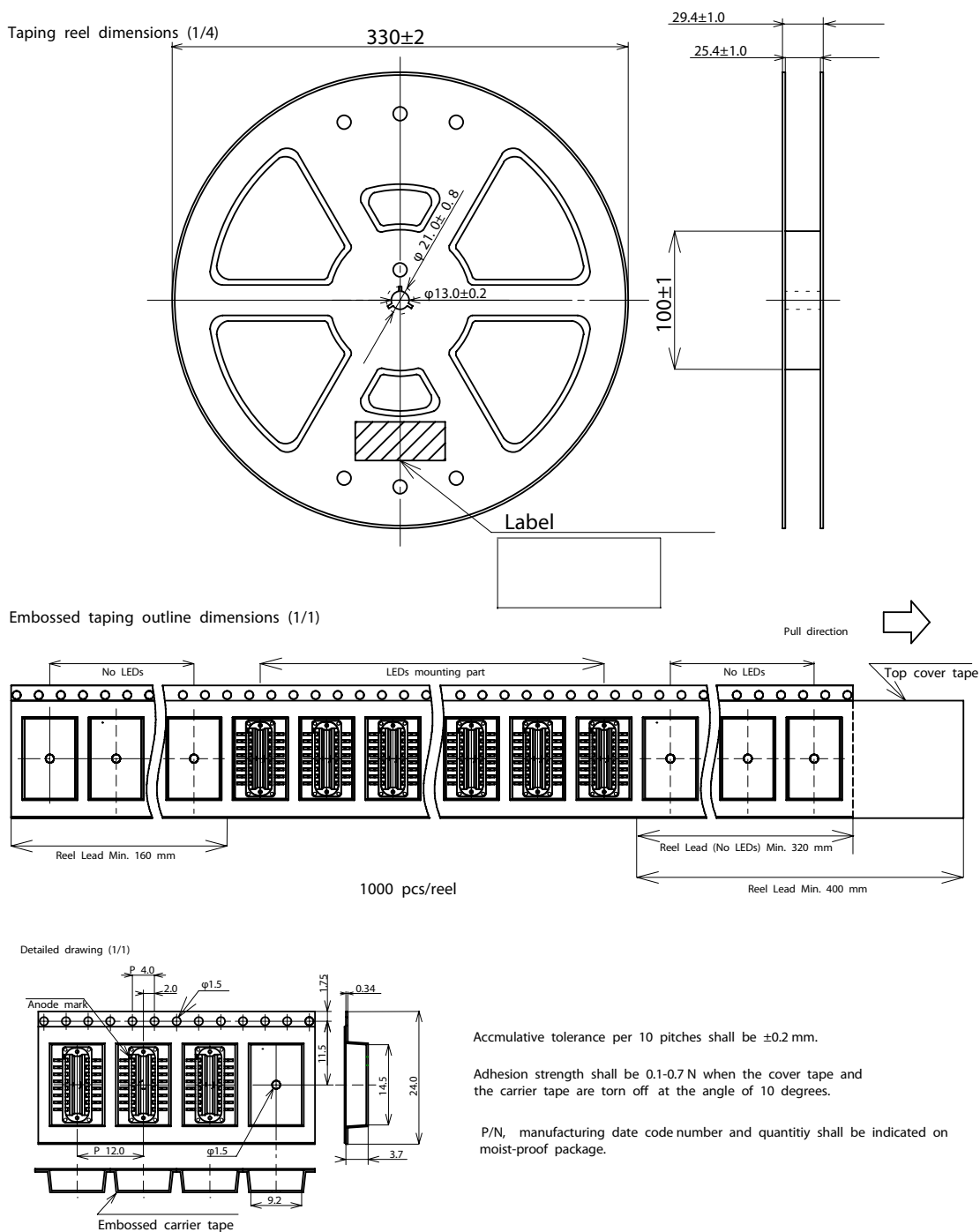

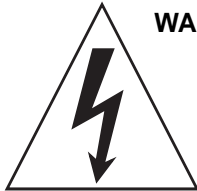

WARNING — These devices are designed to be operated at lethal voltages and energy levels. Circuit designs that embody these components must conform with applicable safety requirements. Precautions must be taken to prevent accidental contact with power-line potentials. Do not connect grounded test equipment. The use of an isolation transformer is recommended during circuit development and breadboarding.

This product series emits high light output. Do NOT look directly into the light emitting area. Direct exposure to the light over an extended time period may harm eyes.

Because reliability can be affected adversely by improper storage environments and handling methods, please observe the following:

Cautions for Storage

- Ensure that storage conditions are within 5°C to 40°C and relative humidity < 30%; avoid storage locations that experience extreme changes in temperature or humidity.
- Avoid locations where dust or harmful gases are present and avoid direct sunlight.
- Reinspect for rust on leads and solderability of products that have been stored for a long time.

Cautions for Testing and Handling

When tests are carried out during inspection testing and other standard test periods, protect the products from power surges from the testing device, shorts between adjacent products, and shorts to the heatsink.

Precautions During Use

- Because the light generated inside the LED must be emitted efficiently out of the module, a resin with high light transmittance is used. Therefore, additives that are commonly used in semiconductor devices to improve the heat resistance or moisture resistance (such as silica glass) cannot be added to the resin. Consequently, the ability of the resin to withstand heat is usually low and the following precautions must be observed.
- Never apply an external force, stress, or excess vibration to resin or terminals when at high temperature.
- Take particular care about heat dissipation when designing the application. If dissipation is not adequate, the LEDs can reach high temperatures, with resulting color change, luminous flux reduction, and shortening of product lifetime.
- When the device is connected to an external radiator, please coat the heatsink area with thermal conduction material such as thermal conductive bond or thermal conductive grease.
- Extra attention should be paid to the sealing resin of the product, which is rubber-like silicon resin. The surface of sealing resin is slightly sticky (surface tack). Therefore, touching the emitting area or exposing it to unclean conditions may cause dust or smudges to adhere to it and possibly penetrate the resin. This could cause deterioration of product characteristics when contacted by materials such as epoxy resin.
- The silver plating of the leadframe may discolor if the product comes into contact with material containing sulfides or if it is exposed to an atmosphere containing sulfide gas.
- The emitting area of the LEDs contains fine gold wires. Touching this area without care may add excess stress on the internal gold wires and may result in disconnection of the internal wires.

Soldering

- The product is in a surface mount package. The product should not be mounted on warped direction of the PCB.
- When the product is mounted by means of solder reflow and the resin is unusually damp, solder dipping may cause interfacial

defoliation. This occurs when a drastic temperature change causes moisture in the resin to evaporate and to swell. Therefore, attention must be paid to the following:

- Examine the moisture-resistant packing before opening. If the indicator color (blue) of the desiccant (such as silica gel) has disappeared, the product must be prebaked as described below.
- After the product packing is opened and staged for assembly, soldering should be carried out as soon as practicable.
- During handling, ambient conditions should be 5°C to 30°C, with relative humidity < 70%
- After 120 hours of exposure, prebake is recommended before soldering; bake-out at 60±5°C for more than 10 hours
- After soldering, no mechanical force or excessive vibration should be applied to the product until the product has cooled down to normal room temperature. Quick cooling must be avoided.
- When soldering the products, please be sure to minimize the working time, within the following limits:

Soldering Iron Temperature (°C)	Time (s)
350±10	3 (once only)

- Reflow soldering can be performed a maximum of 2 times, with preheat conditions of 150°C to 180°C (at the device surface) for 60 to 120 s, and soldering conditions less than 40 s at more than 220°C, with a peak temperature less than 260°C, using the following recommended profile:

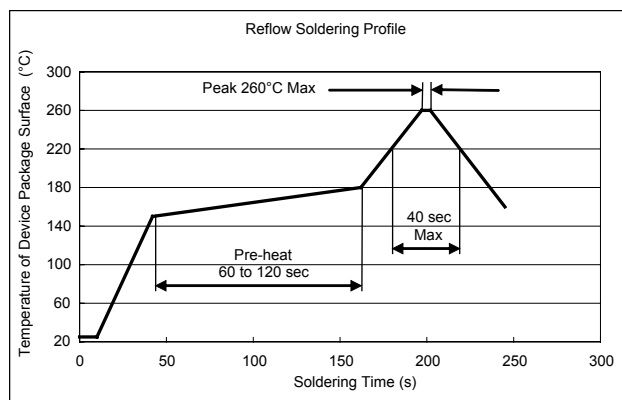

Between the first and second reflow sessions, follow the guidelines in the Cautions for Storage section, above.

Electrostatic Discharge

- When handling the products, operator must be grounded. Grounded wrist straps worn should have at least 1 MΩ of

- resistance to ground to prevent shock hazard.
- Workbenches where the products are handled should be grounded and be provided with conductive table and floor mats.
- When using measuring equipment such as a curve tracer, the equipment should be grounded.
- When soldering the products, the head of soldering irons or the solder bath must be grounded in order to prevent leak voltages generated by them from being applied to the products.
- The products should always be stored and transported in our shipping containers or conductive containers, or be wrapped in

- aluminum foil.
- Exposure to any overvoltage exceeding the Absolute Maximum Rating of the products may cause damage to, or possibly result in destruction of, the products. Buyer shall take absolutely secured countermeasures against static electricity and surge when handling the products.
- Typical anti-static and anti-surge reference circuits are shown below. The circuits shown are for reference only, and the buyer must make a sufficient experimental verification of the static and surge levels when employing the product.

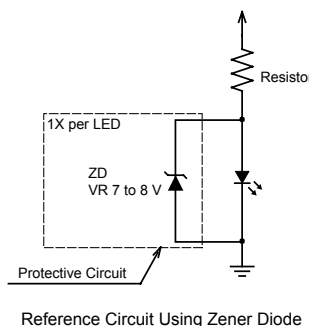
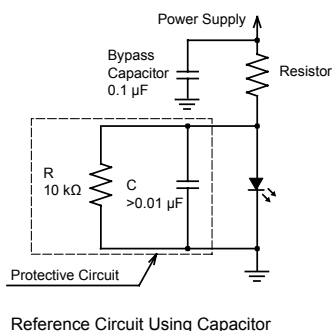

Application and operation examples described in this document are quoted for the sole purpose of reference only, for the use of the products herein, and Sanken can assume no responsibility for any infringement of industrial property rights, intellectual property rights, or any other rights of Sanken or any third party which may result from its use.

When using the products herein, the applicability and suitability of such products for an intended purpose or object shall be reviewed at the user's responsibility.

Although Sanken undertakes to enhance the quality and reliability of its products, the occurrence of failure and defect of semiconductor products at a certain rate is inevitable. Users of Sanken products are requested to take, at their own risk, preventative measures including safety design of the equipment or systems against any possible injury, death, fires or damages to the society due to device failure or malfunction.

Sanken products listed in this document are designed and intended for the use as components in general purpose electronic equipment or apparatus (home appliances, office equipment, telecommunication equipment measuring equipment, etc.). Before placing an order, the user's written consent to the specifications is requested.

When considering the use of Sanken products in the applications where higher reliability is required (transportation equipment and its control systems, traffic signal control systems or equipment, fire/crime alarm systems, various safety devices, etc.), please contact your nearest Sanken sales representative to discuss and obtain written confirmation of your specifications.

The use of Sanken products without the written consent of Sanken in the applications where extremely high reliability is required (aerospace equipment, nuclear power control systems, life support systems, etc.) is strictly prohibited.

Anti radioactive ray design is not considered for the products listed herein.

If there is any discrepancy between English and Japanese versions of this datasheet, the Japanese version should take precedence over the English one.

Please accept in advance that the content of this datasheet is subject to change without notice for the purpose of such as improvement of the product.

Worldwide ContactsAsia-Pacific**China****Sanken Electric Hong Kong Co., Ltd.**

Suite 1026, Ocean Centre
Canton Road, Tsimshatsui
Kowloon, Hong Kong
Tel: 852-2735-5262, Fax: 852-2735-5494

Sanken Electric (Shanghai) Co., Ltd.

Room 3202, Maxdo Centre
Xingyi Road 8, Changning District
Shanghai, China
Tel: 86-21-5208-1177, Fax: 86-21-5208-1757

Taiwan Sanken Electric Co., Ltd.

Room 1801, 18th Floor
88 Jung Shiau East Road, Sec. 2
Taipei 100, Taiwan R.O.C.
Tel: 886-2-2356-8161, Fax: 886-2-2356-8261

Japan**Sanken Electric Co., Ltd.
Overseas Sales Headquarters**

Metropolitan Plaza Building
1-11-1 Nishi-Ikebukuro, Toshima-ku
Tokyo 171-0021, Japan
Tel: 81-3-3986-6164, Fax: 81-3-3986-8637

Korea**Sanken Electric Korea Co., Ltd.**

Samsung Life Yeouido Building 16F
23-10, Yeouido-Dong, Yeongdeungpo-gu
Seoul 150-734, Korea
Tel: 82-2-714-3700, Fax: 82-2-3272-2145

Singapore**Sanken Electric Singapore Pte. Ltd.**

150 Beach Road, #14-03 The Gateway West
Singapore 189720
Tel: 65-6291-4755, Fax: 65-6297-1744

Europe**Sanken Power Systems (UK) Limited**

Pencoed Technology Park
Pencoed, Bridgend CF35 5HY, United Kingdom
Tel: 44-1656-869-100, Fax: 44-1656-869-162

North America**United States****Allegro MicroSystems, Inc.**

115 Northeast Cutoff
Worcester, Massachusetts 01606, U.S.A.
Tel: 1-508-853-5000, Fax: 1-508-853-7895

Allegro MicroSystems, Inc.

14 Hughes Street, Suite B105
Irvine, California 92618, U.S.A.
Tel: 1-949-460-2003, Fax: 1-949-460-7837