

Application Brief D-004

Introduction

Many industrial, commercial, and military systems have LEDs (light emitting diodes) in the front panel to pass information from the system to a user. The success of the front panel design depends on the subjective evaluations of the user. The designer has the task of developing and satisfying quantifiable specifications based on these subjective evaluations. This task can be simplified by having an understanding of how LED displays are optically characterized and how humans perceive these displays.

This application brief will first define the difference between radiometry and photometry (both are means of measuring electromagnetic energy). Next, the radiometric and photometric terms and their corresponding units will be defined to aid in the explanation of how human visual perception is characterized, and enhance the designer's ability to interpret LED display data sheets. With an understanding of human visual perception and the optical characteristics of LEDs, LED display design guidelines will be presented for optimization of an LED display's effectiveness and success.

Photometry and Radiometry Optical Measurement Systems

Photometry deals with flux (in lumens) at wavelengths that are visible to the human eye, so the unit symbols have the subscript "v" and the unit names have the prefix "luminous".

Radiometry deals with flux (in watts) at all wavelengths of radiant energy, so the unit symbols have the subscript "e" and the unit names have the prefix "radiant".

Except for the difference in units of flux, radiometric and photometric units are identical in their geometrical concepts. Luminous flux is related to radiant flux by means of the "luminosity function", $V(\lambda)$, also known as the Standard Photopic Observer curve as shown in Figure 1. At the peak wavelength, 555 nm, of the luminosity function, the conversion factor is 683 lumens per watt. The CIE (Commission Internationale de L'Eclairage) has quantified this curve as well as another luminosity curve, $V'(\lambda)$, characterizing the Standard Scotopic Observer^{1,2}. The Standard Photopic Observer curve models the eye's response to light intensity levels that are typical of everyday outdoor and indoor levels. The Standard Scotopic Observer curve models the eye at very low intensities of light. The scotopic curve is centered at a shorter wavelength than the photopic curve and thus will yield different photometric results. Whether the LED display needs to be read in nighttime or daytime applications, the designer wants the display to supply more than adequate amounts of light intensity to the eye, and generally will not need to be concerned with the scotopic curve.

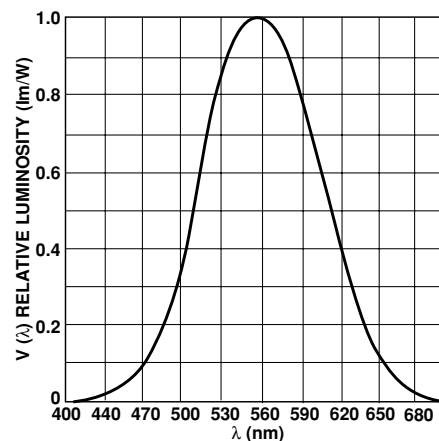

Figure 1. CIE Standard Photopic Observer curve.
At peak (555 nm) 1 Watt = 683 lumens.

The CIE Standard Photopic Observer curve can be considered as the response curve of the human eye to electromagnetic radiation. The eye, a physiological detector, can be modeled by placing a filter with a transmission curve identical to the CIE curve in front of a wideband (equal responsivity across the entire optical spectrum of 400 - 700 nm) radiation detector. A typical photometric measurement setup is shown in Figure 2. Please refer to Appendix A for a supplier list of photometric equipment.

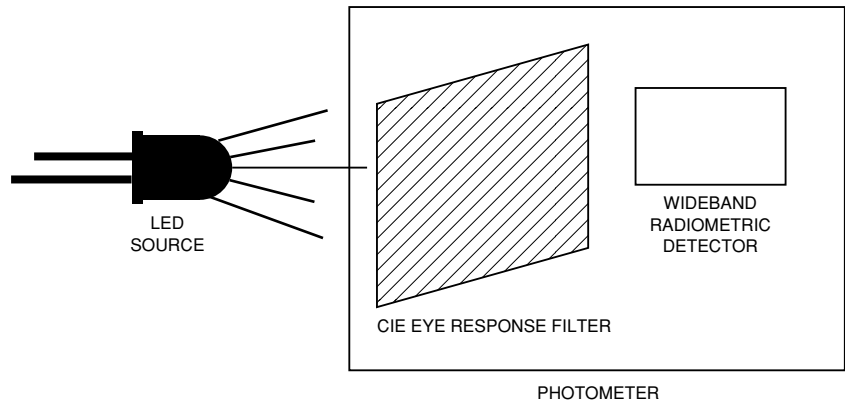

Figure 2. Typical photometric set-up using a CIE response filter to give wideband radiometric detector a human eye characterization.

Geometrical Relationships

Generically, there are only five units (and symbols) for radiant energy, as illustrated in Figure 3.

Φ -FLUX, describes the rate at which energy is passing to, from, or through a surface or other geometrical entity.

E -INCIDANCE, describes the flux per unit area normally (perpendicularly) incident upon a surface.

M -EXITANCE, describes the flux per unit area leaving (diverging) from a source of finite area.

I - INTENSITY, describes the flux per unit solid angle radiating (diverging) from a source of finite area.

L -STERANCE, describes the intensity per unit area of a source.

ω -SOLID ANGLE, a solid angle, ω , with its apex at the center of a sphere of a radius, r , subtends on the surface of that sphere an area, A , so that $\omega = A/r^2$ in steradians (sr).

Adding subscripts and prefixes quantifies these as radiometric or photometric units, e.g.:

I_e -RADIANT INTENSITY - watts per steradian, (W/sr).

I_v -LUMINOUS INTENSITY - lumens per steradian (lm/sr) or candelas (cd), where $cd = lm/sr$.

L_v -LUMINOUS STERANCE - candelas per square meter (cd/m^2)

Flux is used mainly in relating to the other terms. Few applications actually utilize all the flux available from a source. The same is true for exitance. The only situation in which “exitance” and “flux” have practical significance is with a receptor so tightly coupled to a source that virtually all the flux leaving the source enters the receptor, such as in optoisolators.

Incidence has the same units as exitance but is of a vastly different nature. Exitance ignores the direction taken by the exiting flux. Incidence takes account of the flux component which is normal to a

surface. If the flux direction at a surface is not normal, then the incidence is just the normal component of the angularly incident flux density. Incidence is most useful in describing photodetector properties.

Intensity is an extremely useful concept in both photometry and radiometry, and the candela unit of luminous intensity is the only universally utilized photometric unit. Since flux passing through space is usually divergent, it is usually possible to define an equivalent point from which it diverges in terms of a solid angle, the flux therein, and hence the intensity of the equivalent point. Intensity is the most easily measured and most uniformly repeatable quantity. Therefore, although sterance is more fundamentally significant in many applications, the actual parameter to be measured for performance verification should be the intensity.

Sterance is most significant because of its constance in optical (lens) systems. This is discussed in much detail in the National Bureau of Standards publication NBS

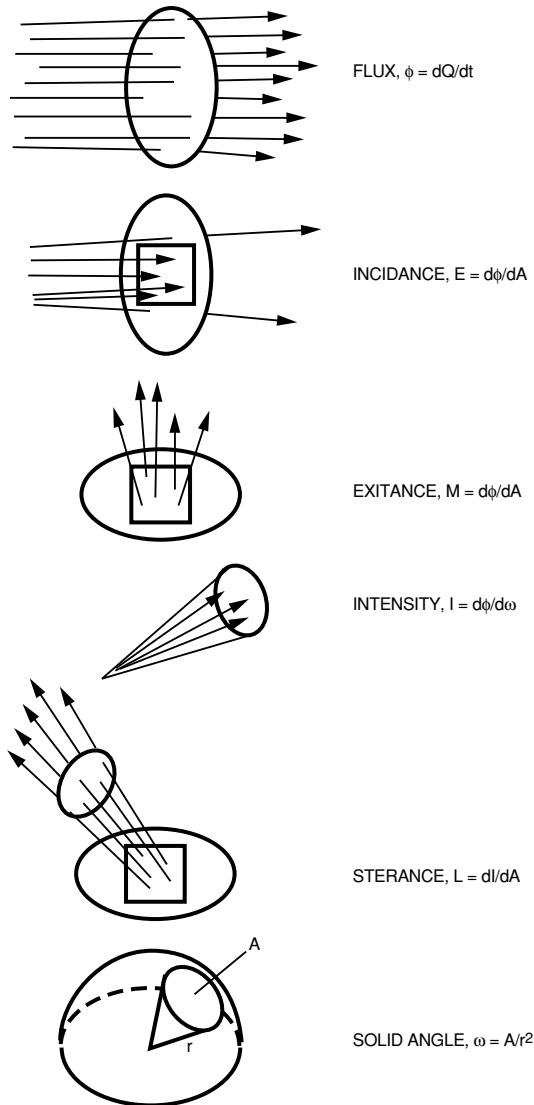

Figure 3. Generic terms and symbols and their geometrical relationships.

Technical Note 910-1. While magnification and image position vary, sterance does not. Luminance sterance (luminance) is the luminosity basis for visibility. This quantifies how well an object can be distinguished from its background. As such, luminous sterance is a useful measure for contrast and photographic exposure. The spatial radiation pattern of an LED device is determined by the optics of the package. An idealized emitter has what is termed a Lambertian radiation

pattern, a spherical pattern where the intensity varies as the cosine of the off axis angle, $I_V(\theta) = I_V(0)\cos(\theta)$. The radiation pattern from flat surface devices, such as light bars and streaked segment displays, approximates a Lambertian radiation pattern. Since the size of flat surface emitting areas, when viewed off-axis, varies as the cosine of the off-axis angle, θ , the luminous sterance of these devices is constant with respect to off-axis viewing. For these LED sources,

sterance can be simplified to I_V/A , where A is the area of the emitting surface.

Please see Appendix B for more information containing radiometric and photometric quantities, defining equations, and corresponding units¹.

Color

Luminous sterance is not the only basis for visibility; color is another. For example, a yellow mustard stain on a green shirt is visible, even if the spot has the same luminous sterance as the shirt. On a yellow shirt of the same color as the mustard, the spot would only be visible if its luminous sterance is different by a factor of two. The CIE Chromaticity Diagram shown in Figure 4 is used to define the color of a light emitting object in terms of a two-dimensional coordinate system. A monochromatic source's coordinates would lie on the perimeter of the curve, whereas a source that had an emission spectrum of many wavelengths would have its characteristic coordinates towards the center of the diagram which is representative of "white" color (weighted combination of red, blue, and green wavelength emission)^{1,3,4}. A line drawn from a reference "white light" source through an interior point defines the color in terms of a single wavelength where that line crosses the perimeter.

To present the historical development, derivations, and computational uses of the CIE Chromaticity Diagram is a complete topic of its own. References have been provided for the interested reader.

Table 1 lists the CIE x-y color coordinates for the various LED materials that are currently avail-

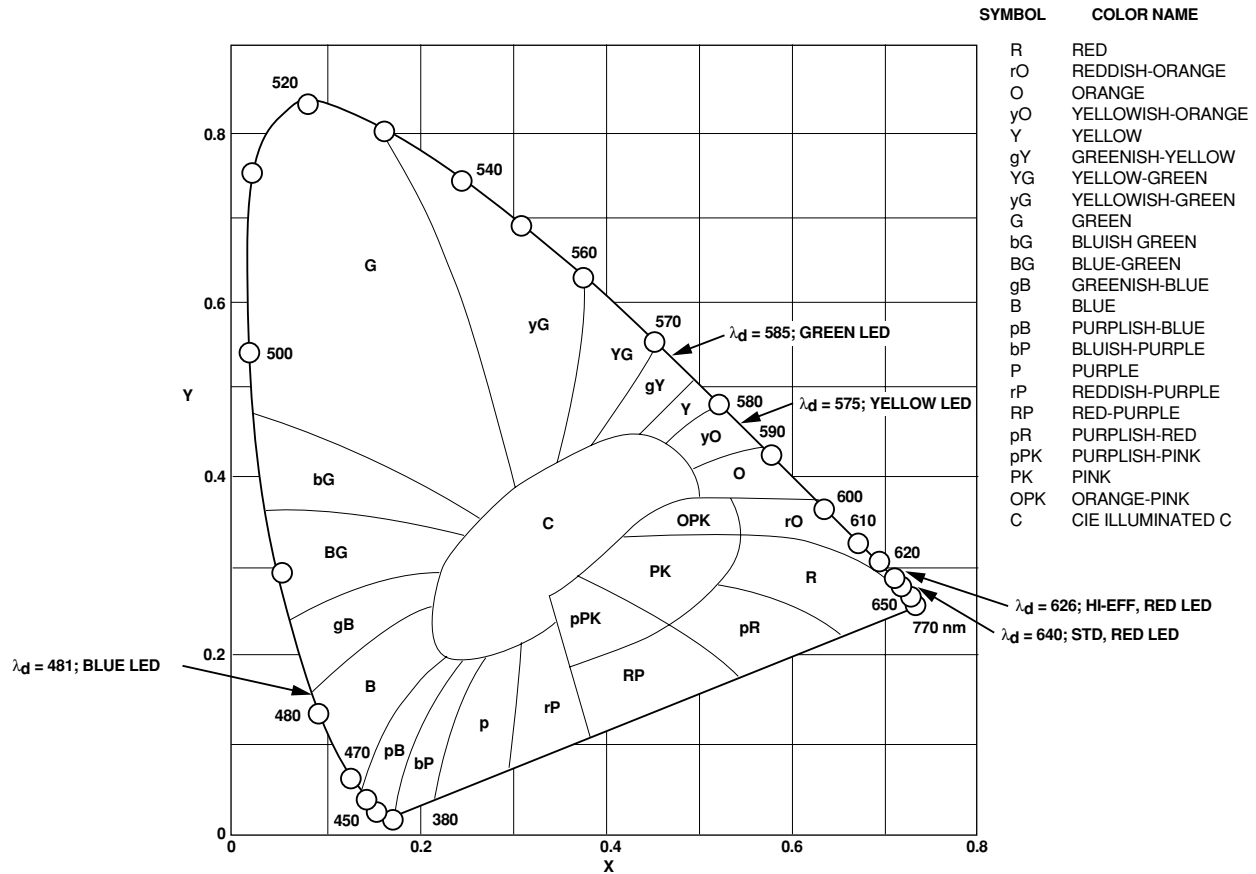

Figure 4. Dominant wavelengths and corresponding colors for LEDs shown on the CIE Chromaticity Diagram.

able. The table also gives the LED material's luminous efficacy, dominant wavelength, and the dominant wavelength and output intensity dependencies on temperature. These quantities will be addressed and identified in the following section on how an LED is optically measured and characterized on a data sheet.

Electro-Optical Design Guidelines For LED Displays

There are several design guidelines that one can use to simplify a design. They are based on characteristics of the eye and LEDs. Guidelines are given for:

- Multiplexing
- Pulse-width-modulation dimming
- Brightness matching

Multiplexing

For some applications, dc driving an LED with a single current limiting resistor is sufficient. However, as designs become more complex, dc driven designs become expensive and consume large amounts of board space. Multiplexing LEDs is a better alternative.

Figure 5 shows a simple block diagram of a circuit that multiplexes "n" seven segment displays. Each digit has a separate digit driver, but the seven segments of each display share segment drivers. The circuit decodes the correct segments for digit one and turns digit driver one on for a short time. Next, the circuit decodes the correct segments for digit two and turns digit driver two on for a

short time. If the sequence is repeated fast enough, the digits appear to be on simultaneously to the eye.

How fast should the sequence be for this simultaneous appearance to occur? The 50 to 60 Hz flicker frequency of television pictures is not usually noticeable, but the minimum recommended refresh rate (the number of times per second a part is pulsed) for LEDs is 100 Hz. Refresh rates below 100 Hz may initially appear flicker free, but the other factors besides refresh rate may cause flicker to be noticed. For example, a stationary display with a low refresh rate may appear to flicker as people walk by. Similarly, a display in an airplane cockpit may appear to flicker due to the vibration of the airplane.

Table 1. LED Material Characteristics

LED Die	Intensity vs. Temperature Coefficient (%/°C) k	Wavelength vs. Temperature Coefficient (nm/°C)	Dominant Wavelength λ_d (nm)	Luminous Efficacy η_v (lm/W)	CIE Color Coordinates
Standard Red	-1.88	0.18	640	65	x = 0.719 y = 0.280
TS AlGaAs	-1.30	0.18	637	85	x = 0.716 y = 0.283
AS AlGaAs	-0.95	0.15	637	80	x = 0.716 y = 0.283
HER	-1.31	0.14	626	145	x = 0.702 y = 0.297
Orange	-1.31	0.14	602	380	x = 0.635 y = 0.363
Reddish-Orange AS AlInGaP	-1.14	0.13	622 / 615	197 / 263	x = 0.695 / 0.680 y = 0.304 / 0.320
Amber AS AlInGaP	-1.14	0.13	592	500	x = 0.575 y = 0.424
Yellow	-1.12	0.13	585	500	x = 0.544 y = 0.454
High Performance Green	-1.04	0.12	570	595	x = 0.437 y = 0.561
Emerald Green	-1.04	0.12	560	656	x = 0.437 y = 0.561
Blue	NA	NA	481	134	x = 0.150 y = 0.1914

When operating an LED part under dc drive conditions, the junction temperature is a linear function of the dc power dissipation multiplied by the thermal resistance, plus the ambient temperature. The light output is proportional to the dc drive current.

When operating an LED part in the pulsed mode, it is the peak junction temperature (not the average) that determines the allowed time averaged power dissipation and light output. The lower the peak junction temperature, the higher the light output. At slow refresh rates in the range of 100 Hz, the peak temperature is greater than the average temperature because the junction has enough time to reach the peak value during the

“on” time. As the refresh rate approaches 1000 Hz, the value of the peak temperature approaches the average value. Therefore, it is recommended that whenever possible, LED parts be refreshed at a rate of 1 kHz or faster. Since at these faster pulse rates, the peak and average junction temperatures are assumed to be equal and the light output is a function of the average temperature.

Pulse-width-modulation

The eye averages light intensity over time. Figure 6 shows a plot of peak and average current and light intensity. By varying the duty factor (ratio of on time to total cycle time) you can adjust the brightness linearly across a wide range. This type of dimming is

called pulse-width-modulation (PWM). Ranges of 2000:1 are achievable with this method. Wide dimming ranges are needed when the design is viewed in a wide range of ambient light conditions. For example, displays in airplane cockpits are subject to ambient ranging from dim nighttime to bright sunlight.

A minimum of 10 mA peak current is recommended for most parts. A minimum of 5 mA peak current is recommended for low current parts. Peak currents below the recommended values may cause part to part mismatch. These low peak current values will give acceptable matching across a wide range of duty factors, but may not provide sufficient brightness for all

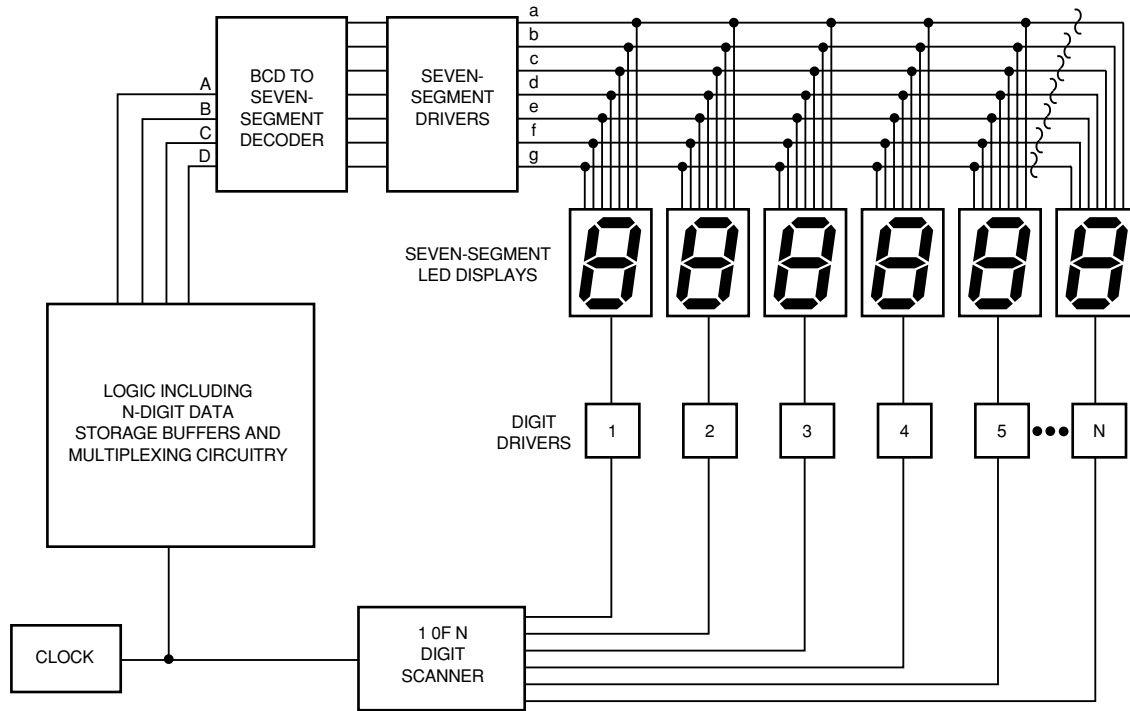

Figure 5. Circuit configuration used to multiplex LED characters. The same methodology applies for dot matrix and sixteen segment displays.

applications. In addition to dimming an LED, the power consumption decreases linearly with the duty factor. Thus, if the intensity is decreased by reducing the duty factor by two, the power consumed is also reduced by two.

Driving LEDs with a 50 or 60 Hz half or full-wave rectifier ac source is not recommended. Determining the drive current needed to achieve a given intensity is very difficult. This occurs because the drive current is always changing with time, and thus the intensity changes at every instant. Therefore, predicting the time averaged intensity is very difficult since the intensity versus peak current level is a non-linear response.

Changing the refresh rate does not change the effects due to PWM since the percentage of on time (duty factor) remains the same.

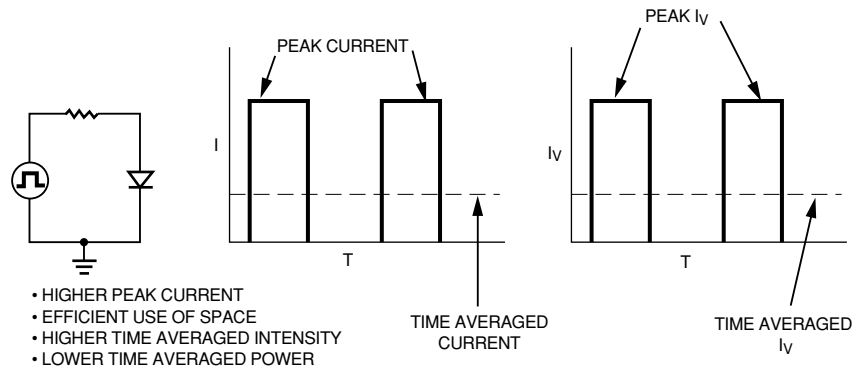

Figure 6. Pulse driving scheme showing peak and average current and intensities, where the average value = peak value times duty factor.

Brightness Matching

The eye can perceive relative luminous sterance, but not absolute luminous sterance. While we can make reasonable estimates of actual distance, we cannot make reasonable estimates of actual brightness. For example, we can make a good estimate of one inch, but we cannot make a good estimate of one candela per square meter.

Perceived brightness is a highly subjective experience and depends heavily on the ambient light conditions. If LEDs were only viewed in a darkened room then the brightness of different color LEDs could be matched based only on the measured intensity (cd) or sterance (cd/m^2).

As the eye is stimulated by a source containing various wavelengths, it becomes fatigued and its sensitivity to these wavelengths is lowered. Thus, to see a source in a given ambient, the source has to emit enough light to overcome the eye's fatigue caused by the ambient lighting. The ambient light spectrum also influences the relative amount of light different colored sources need to emit to be perceived as equally bright. Table 2 shows typical levels of indoor ambient lighting. Figure 7 shows minimum acceptable light output for LED parts under different ambient lighting conditions and using an 18 % transmission neutral density gray contrast enhancement filter.

The daylight spectrum peaks in the green-yellow region, so when looking at things in daylight, your eye becomes fatigued and has less response to these colors than to colors at the red or blue end of the spectrum. Indoor light also peaks in the green-yellow region, but is not as bright. As a further note, an incandescent lamp peaks in the infrared region.

Typical brightness differences of 2:1 are just noticeable. For example, for identical LED packages, a green LED with an intensity of 10 mcd of green will appear similar to a green LED with an intensity of 15 mcd. However, due to ambient lighting conditions the 2:1 ratio does not hold when comparing two different color LEDs. Thus, for identical LED packages, 10 mcd of green will not appear as bright as 10 mcd of red. Table 3 shows recommended scaling factors for different LED colors and with and without the 18 % transmission gray filter. Refer to Application Note 1031⁵ for a detailed explanation on

Table 2. Indoor Incident Ambient Light Levels

Indoor incident ambient light	Lux (lm/m ²)	fc (lm/ft ²)
General indoors (corridors, stairways)	200-500	20-50
Desktop level (general reading, writing)	500-1100	50-100
Moderately bright (detailed drafting)	1100-2150	100-200
Bright interior (fine bench/machine work)	2150-5400	200-500

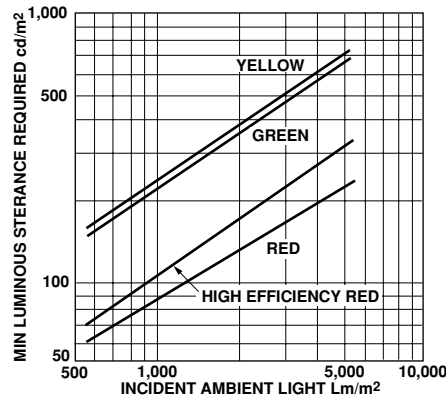

Graph 1. Minimum Acceptable Light Output of Unfiltered Displays vs. Level of Incident Ambient Light

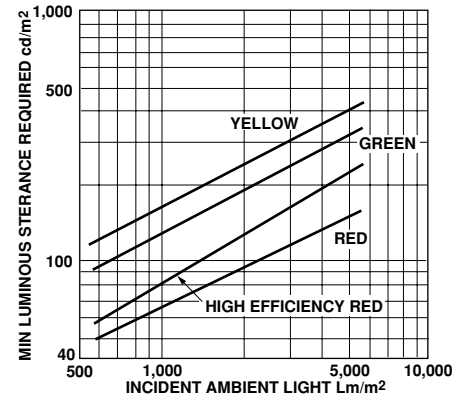

Graph 2. Minimum Acceptable Light Output of Displays Prior to Filtering with an 18 % Transmission Neutral Density Gray vs. Level of Incident Ambient Light

Figure 7. Graphs showing the minimum acceptable light output required by filtered/unfiltered displays vs. various levels of incident ambient light.

how to match LEDs for sterance under indoor ambient lighting environments. Application Notes 1015⁶ and 1029⁷ present detailed information on how to accomplish sunlight viewability.

How an LED is Optically Measured and Characterized on a Data Sheet

Data sheets provide useful information about the optical performance of LEDs. To use this data wisely, an understanding of what these characteristics are and how they are measured is helpful. LEDs are manufactured in a wide variety of packages. All of the different information is not always needed to complete a successful design.

Data sheets typically include specifications for:

- Luminous Intensity
- Dominant Wavelength
- Peak Wavelength
- Spectral Line Halfwidth
- Speed of Response
- Luminous Efficacy
- Included Angle between Half Luminous Intensity Points

Data sheets typically include graphs of:

- Relative Intensity vs. Wavelength
- Relative Luminous Intensity vs. DC Forward Current
- Relative Efficiency vs. Peak Current
- Relative Luminous Intensity vs. Angular Displacement

Table 3. Sterance ratio required of LED colors to achieve equal brightness relative to HER

	Red AS/TS AlGaAs	HER/Reddish- Orange AlInGaP	Yellow/ Amber AlInGaP	Green
Unfiltered	0.75	1.0	2.2	2.1
Filtered (18 % gray)	0.83	1.0	2.0	1.7

Luminous Intensity, I_V

Luminous intensity is measured for every part. The luminous intensity of an LED lamp listed on a data sheet is a single point, on-axis measurement at a specified test current. The current is controlled by a current source, thus avoiding the effects due to forward voltage variations. The tester compares the measured I_V allowed for the part and rejects parts with I_V measurements below this value. Typical I_V values for LED devices are in the microcandela to millicandela range. However, recent advancements in LED technology have produced lamps with luminous intensities in the range of several candelas. In addition to visible applications, these high intensity lamps are also used in non-visible applications and so a typical value for radiant intensity is provided.

Total flux emitted from chip to chip for a given LED material is consistent for a fixed drive current. However, package design determines how this energy is distributed in space. These different package designs can be used to create lamps with different intensity and included angle characteristics. Thus the flux can be focused into a narrow included angle with a high on-axis intensity, or it can be diffused across a wide included angle with a lower on-axis intensity. Therefore, as the on-axis intensity increases, the included angle decreases. For very narrow included angle parts, $2\theta_{1/2} < 10^\circ$,

the peak intensity may not be located on-axis. For these parts, the industry practice is to scan a cone of $\pm 5^\circ$ to locate the peak intensity.

Since the intensity is a single point measurement, it is not possible to compare the intensity value for an LED lamp with the mean spherical candela (candle power) rating of an incandescent lamp. The mean spherical candela is a unit used to measure the light output of incandescent bulbs. The average of these test points is the number of mean spherical candelas emitted by the bulb. Because LEDs do not emit light in a spherical pattern, this type of measurement has no meaning.

The intensity for each segment of a seven segment display is measured. The average measured segment I_V is then compared against the minimum allowed I_V for the part and rejects parts with I_V measurements below this value.

The intensity of a test character is measured for each digit of a dot matrix display. The average measured test character I_V is then compared against the minimum allowed I_V for the part and rejects parts with I_V measurements below this value.

Dominant Wavelength, λ_d

Dominant wavelength is derived from the CIE Chromaticity Diagram and defines a color in terms of a single wavelength. It is that

single wavelength of light that has the same perceived color as the LED radiated spectrum.

The dominant wavelength of an LED is closely related to the material used to make the LED. The eye's sensitivity to process variations in the color of green, yellow, and amber LEDs as shown in Figure 8 necessitates color binning by dominant wavelength for these colors. The other colors are not screened for color. The dominant wavelength of an LED cannot be significantly changed by a filter. Table 1 correlates dominant wavelengths with LED materials.

Peak Wavelength, λ_{PEAK}

Peak wavelength, measured in nanometers, is that single wavelength where the radiant intensity is at maximum. Peak wavelength is a characteristic of the LED material and is not measured on a production basis. Process variations are about ± 10 nm.

Spectral Halfwidth, $\Delta\lambda_{1/2}$

The spectral halfwidth is the width of the radiated spectrum between the 1/2 radiometric intensity points, measured in nanometers. Spectral halfwidth is a characteristic of the LED material and is not measured on a production basis.

Speed of Response

The speed of response is the value of one time constant. After five time constants, the LED is assumed to have switched from either off to on or from on to off. The 10% to 90% transition time is estimated as 2.2 times the time constant given in the data sheet. Speed of response is a characteristic of the LED material and is not measured on a production basis.

Luminous Efficacy, η_V

Luminous efficacy is the ratio of luminous flux to radiant flux, lm/W. Luminous efficacy is a characteristic of the LED material and is not measured on a production basis. The radiometric intensity can be calculated by dividing the luminous intensity by the luminous efficacy, $I_e = I_V/\eta_V$. The luminous efficacy for various LEDs is given in Table 1 or can be read directly from the CIE curve in Figure 1.

Included Angle between Half Luminous Intensity Points, $2\theta_{1/2}$

Figure 9 shows a graphical definition of included half-angle. $\theta_{1/2}$ is the angle formed by the optical axis and the point where the intensity has decreased to 50% of the on-axis intensity. Thus $2\theta_{1/2}$ is the angle between the 50% point on one side of the optical axis and the 50% point on the other side.

The spatial radiation pattern of an LED device is determined by the optics of the package. An idealized emitter has what is termed a Lambertian radiation pattern, a spherical pattern where the intensity varies as the cosine of the off-axis angle, $I_V(\theta) = I_V(0) \cos\theta$. The radiation pattern from flat surface devices, such as light bars and seven segment displays, approximates a Lambertian radiation pattern. Since the size of flat surface emitting areas, when viewed off-axis, varies as the cosine of the off-axis angle, the luminous sterance of these devices is constant with respect to off-axis viewing. Thus $\theta_{1/2}$ is not specified for these parts.

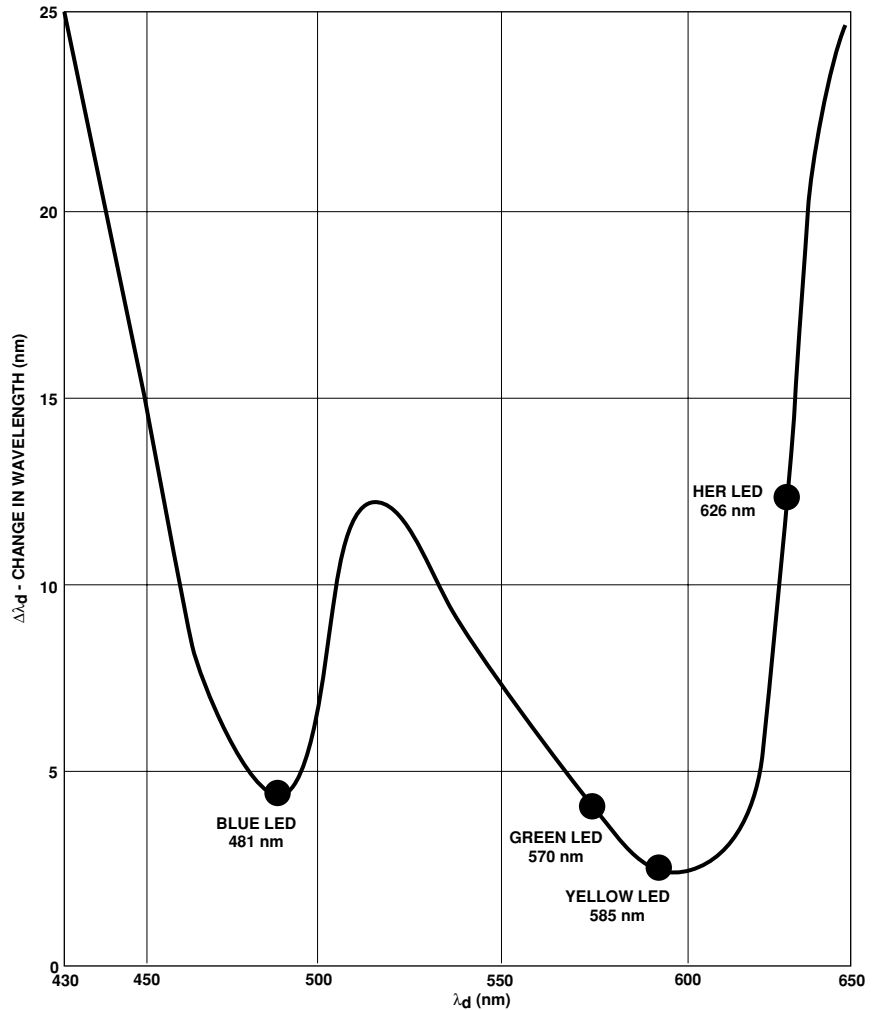

Figure 8. Eye threshold to a color difference.

Relative Radiant Intensity vs. Wavelength

This graph is based on the LED material characteristics. Each curve has been normalized to one based on the peak spectral radiant intensity. Thus relative comparison between different colors cannot be made using these curves. Of significance is the narrow bandwidth. For example, there is very little blue energy in a green LED,

and there is no blue energy in an AlGaAs red LED. A secondary infrared emission is not shown on these graphs, but is significant for some non-visible applications and for those applications with a night vision goggle requirement. This emission is caused by the LED substrate material. Only TS AlGaAs does not have secondary infrared emission.

Relative Luminous Intensity vs. DC Forward Current

This graph is normalized to one at the same current that the intensity for the part is measured. Intensity is roughly proportional to current. When estimating intensity at currents very different from the test (e.g. when dimming), this approximation is poor and not recommended.

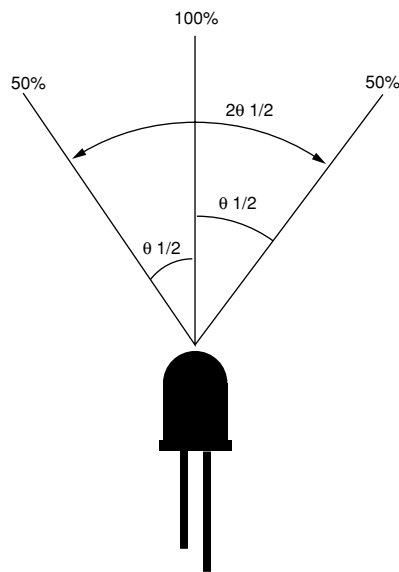

Figure 9. Half-angle $\theta_{1/2}$, or viewing angle $2\theta_{1/2}$ geometry with regards to data sheet specification.

radiation pattern for the part. This curve is normalized to one for the peak intensity. This curve is created by measuring the intensity of the lamp as it is related to the detector. The average of several different lamps is used to determine the curve.

The total flux output of an LED lamp may be obtained by integrating the luminous intensity through the spatial radiation pattern. The most accurate way to measure total flux is to use an integrating sphere. The LED device is placed inside the integrating sphere that captures all of the emitted flux from the device for measurement.

A typical relative luminous intensity vs. angular displacement graph has an additional curve as shown in Figure 10. This curve can be used to calculate the total flux captured within an angle.

Relative Efficiency vs. Peak Current, η_{IPEAK}

This graph is similar to the relative luminous intensity graph except that the power consumed by the LED is kept constant during pulsed operation. This is done by increasing the peak current while reducing the duty factor.

Relative Luminous Intensity vs. Angular Displacement

This curve is a two dimensional representation of the spatial

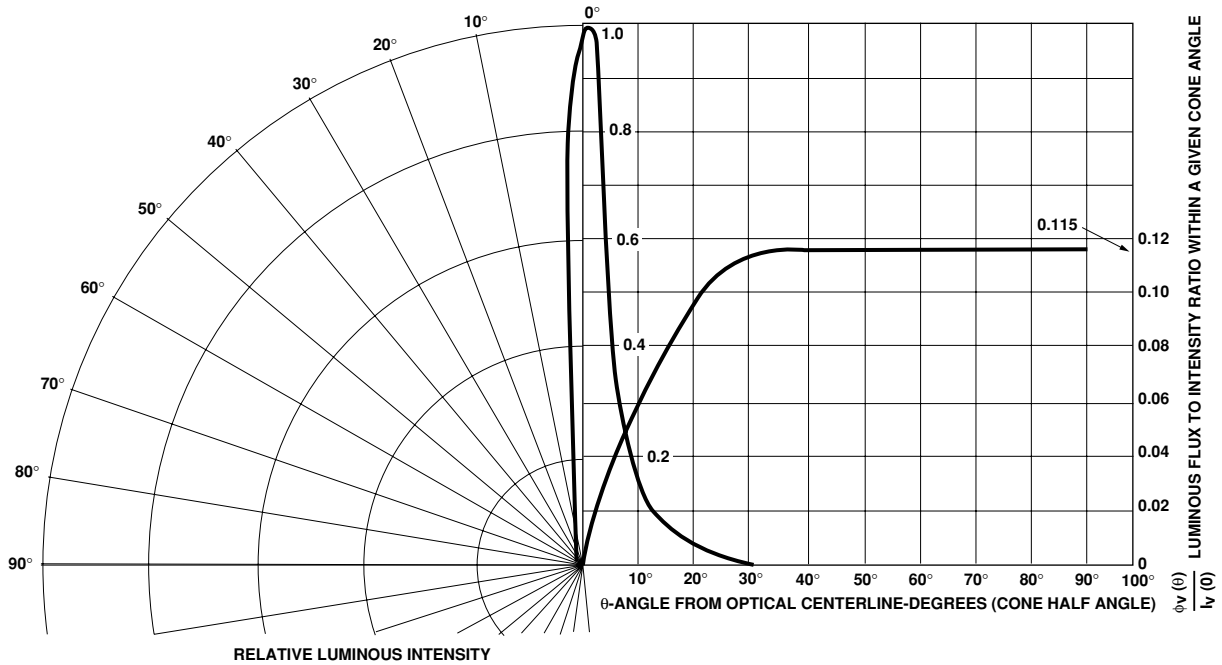

Figure 10. Relative luminous intensity vs. angular displacement.

How to Calculate Light Output at Different Currents and Operating Temperatures

The time averaged luminous intensity (I_V) at $T_A = 25^\circ\text{C}$ for a particular drive condition may be calculated using the relative luminous intensity characteristic for DC operation or the relative efficiency characteristic (η_{PEAK}) for pulsed operation. These curves are on all data sheets and show the results for each LED material. Figures 11 and 12 are shown for illustrative purposes. For DC operation, $I_V (T_A = 25^\circ\text{C})$ is equal to the product of the data sheet luminous intensity specification times the relative factor for a specific DC current from Figure 11.

$$I_{V\text{DC}} = (I_V\text{DATA SHEET}) (\text{FACTOR FROM FIGURE 11}) \quad (1)$$

where $I_{V\text{DC}}$ is the intensity at the specified DC current. $I_V\text{DATA SHEET}$ is the intensity specified on the data sheet at a specific test current.

FACTOR FROM FIGURE 11 is the relative intensity value at the specified DC current.

For example, if the I_V is 5 mcd, the I_V at 20 mA is

$$28 \text{ mcd} = 5 \text{ mcd} \times 5.6$$

5.6 is found by drawing a vertical line at 20 mA in Figure 11. A horizontal line is drawn from where the vertical line intersects the curve. The value is then read from the vertical axis.

For pulsed operation, the time averaged luminous intensity at $T_A = 25^\circ\text{C}$ is calculated using the following equation:

$$I_{V\text{TIME AVG}} = (I_{\text{AVG}}/I_{\text{AVG DATA SHEET}}) (\eta_{\text{PEAK}}) (I_V \text{ DATA SHEET}) \quad (2)$$

where $I_{V\text{ TIME AVG}}$ is time averaged intensity,
 I_{AVG} is the average forward current through an LED,

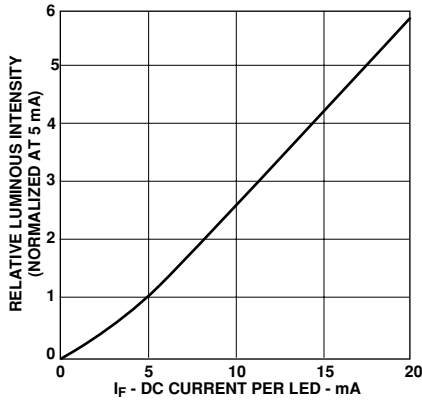

Figure 11. Relative Luminous Intensity vs. DC Forward Current.

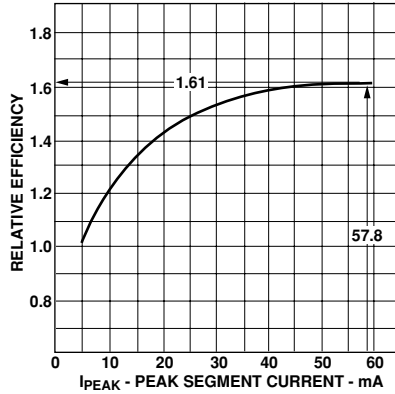

Figure 12. Relative Luminous Efficiency (luminous intensity per unit current) vs. Peak Segment/pixel Current.

I_{AVG} DATA SHEET is the average current at which I_V DATA SHEET is measured, and η_{IPEAK} is the relative efficiency value at the peak current as shown in Figure 12.

For example, if the I_V is 10 mcd at 5 mA, the I_V at 57.8 mA peak current and a 20% duty factor is

$$37.2 \text{ mcd} = [(57.8) (0.2) / 5] \times 1.61 \times 10$$

I_{AVG} is 57.8 mA x 20% duty factor or 11.56 mA. I_{AVG} DATA SHEET is 5 mA. 1.61 is found by drawing a vertical line at 57.8 mA in Figure 12. A horizontal line is drawn from where the vertical line intersects the curve. The value is then read from the vertical axis.

The luminous intensity value at T_A = 25°C is adjusted by the following exponential equation to obtain the light output value at the operating ambient temperature.

$$I_V (T_A \text{ OPERATING}) = I_V (25^\circ\text{C}) \exp [k (T_A - 25^\circ\text{C})] \tag{3}$$

Table 1 shows the k values for different LED materials.

Refer to Application Note 10058 for detailed information on electro-optical design calculations.

How to Correlate Your Optical Tests with Avago’s Optical Tests

Testing optical parameters by third party vendors may result in different values. There are several potential causes for these differences. Ideally, both test systems can trace their calibration back to the United States National Institute of Standards and Technology (NIST), formerly the National Bureau of Standards (NBS). Even when both test systems are calibrated to NIST, different values can be measured for the same parts, and intensity correlation within 10% is considered acceptable.

There are several potential factors responsible for these differences. These factors are:

- CIE filter
- Detector size
- Distance between the device and the detector
- DUT (device under test) alignment between the mechanical and optical axis
- View angle of the DUT
- Non-calibrated measurement system

The test system detectors may need to have their response adjusted to match LEDs. Most manufacturers of photometers make very accurate approximations to the spectral response given by the CIE Standard Photopic Observer. This accuracy is achieved through combinations of filter and the detector response, with positive deviations at some portions of the spectrum compensated by negative deviations in others. While this approach is satisfactory for measurement of light from sources having a broad spectrum (e.g. sunlight, incandescent lamps, fluorescent lamps), a

photometer calibrated from a broad-band source may have substantial error when applied to measurement of narrow-band sources (e.g. LEDs). Flux from narrow-band sources may be entirely in the wavelength region at which a photometer response deviation is either all positive or negative. Note in Figure 1, in the 630 - 650 nm wavelength region, typical for red color LEDs, the CIE $V(\lambda)$ curve falls from 26.5% to 10.7% of the peak value. If the photometer response deviation in this wavelength range is only a few percent of peak, it would lead to values of 20 - 30% deviation from the correct response at the LED wavelength. For accurate LED light measurements, the photometer must be calibrated at or near the LED wavelength.

When making intensity measurements for a discrete LED source (this includes packages containing a single die as in a T-1 lamp or an individual segment in a seven-segment or bar graph display), the solid angle defined by the source detector pair must be calculated. Two approximations can be made to simplify the solid angle calculation: the light emitting device is a point source, and the flat area of the detector is treated as the subtended surface area of the sphere being illuminated by the source at the center of the sphere. This geometrical scheme is shown in Figure 13. These two approximations give small result errors of less than 1% if the "TEN DIAMETERS" rule is implemented. This rule states that the distance between the emitter and the detector must be ten times the diameter of the source or the detector, whichever is larger. Take the case where the flux in lumens is given by a photometer. The included solid angle used to

determine the flux is the photometer's detector area divided by the square of the distance between the emitter and detector ($\omega = A/r^2$). The intensity in lumens/steradian (candela) is the photometer reading divided by the solid angle.

Misalignment between the mechanical and optical axis during testing can cause significant errors. Figure 14 illustrates an exaggerated alignment problem between the mechanical and optical axis. Notice the on-axis radiation will miss the detector. Thus the detector is measuring an off-axis value. This problem is at worst case for very narrow viewing angle parts.

The viewing angle can cause large differences when measuring very narrow viewing angle parts, $2\theta_{1/2} < 10^\circ$. The industry practice is to scan a cone of $\pm 5^\circ$ to locate the

peak intensity for very narrow viewing angle parts. This value can be significantly different from the on-axis intensity.

The instruments used to measure the electro-optic characteristics of the DUT are made up of electro-optic devices themselves. These instruments, like the DUTs, will eventually deviate from their nominal performance characteristics. When making measurements, there has to be a calibrated emitter or detector that can be used to calibrate the rest of the measurement system so present and future data can be compared to previous data.

This will eliminate most differences. Calibrated parts are available on a special order basis. Contact your Avago Technologies field sales engineer for details on how to order calibrated parts.

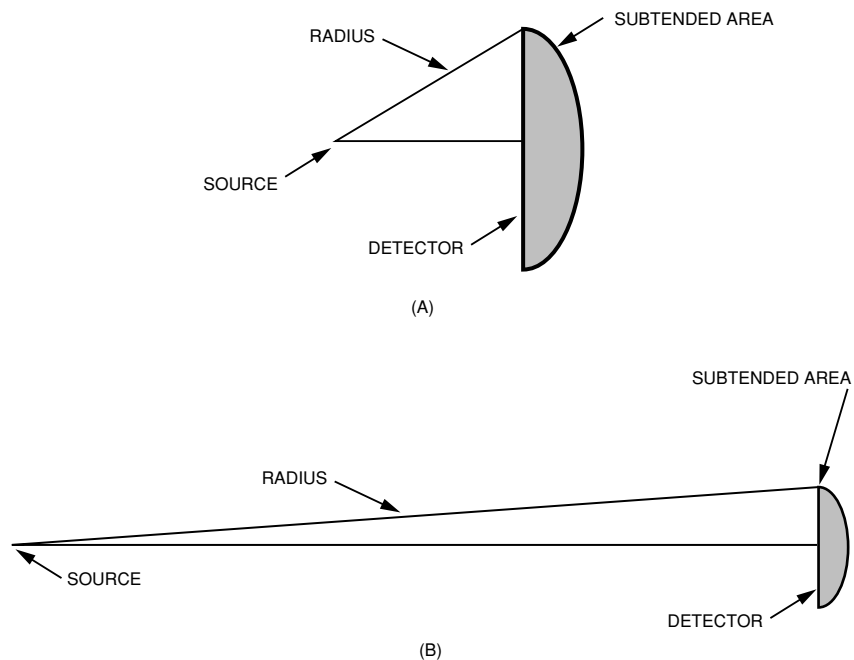

Figure 13. Source/detector configurations where (A) detector area should not be approximated as equivalent to subtended area of the calculated solid angle, (B) detector area can be approximated as subtended area and the TEN DIAMETERS rule applies.

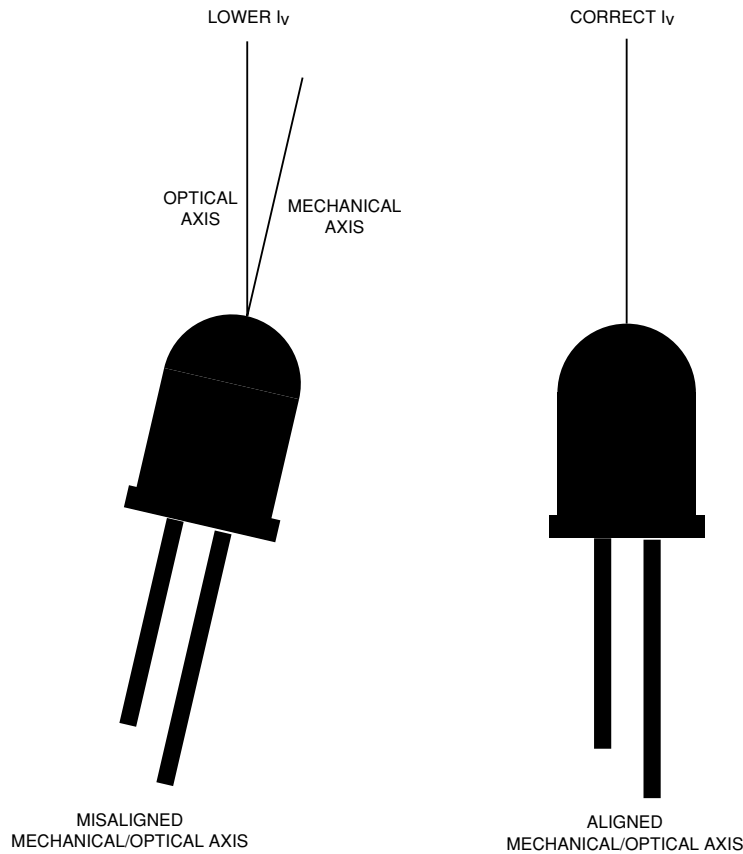

Figure 14. Misaligned mechanical and optical axes which can lead to significant measurement errors.

Summary of Key Points

- The ability to perceive light varies from observer to observer.
- The CIE Standard Photopic Observer curves are used for consistent and repeatable measurements.
- The eye sees relative brightness, not absolute brightness.
- Intensity is used to measure the optical output of an LED.
- Recommended minimum refresh rate: 100 Hz, optimum refresh rate: 1000 Hz.
- Differences in brightness are noticeable above 2:1 for like colors.
- Brightness differences between different LED materials have to be scaled due to ambient lighting conditions.
- Pulse-width-modulation gives a wide dimming range.
- Higher on-axis intensity implies narrow viewing angle for a given LED material.
- The color (dominant wavelength) of an LED cannot be significantly changed by filters.
- Always compare new emitter/detector devices against a calibrated device before taking measurements.

References

1. G. Wyszecki and W.S. Stiles, *Color Science: Concepts and Methods, Quantitative Data and Formulae*, 2nd ed. New York: John Wiley & Sons, 1982.
2. CIE Publication Number 41, 1978, "Light as a True Visual Quantity: Principles of Measurement."
3. T.N. Cornsweet, *Visual Perception*, Orlando, FL: Harcourt Brace Jovanovich, 1970.
4. L.M. Hurvich, *Color Vision*, Sunderland, MA: Sinauer Associates, 1981.
5. Avago Technologies Application Note 1031, "Achieving Uniform Front Panel Appearance Using Avago's S02 Option LED Devices."
6. Avago Application Note 1015, "Contrast Enhancement Techniques for LED Displays."
7. Avago Application Note 1029, "Luminous Contrast and Sunlight Readability of the HDSP-238X Series LED Alphanumeric Displays for Military Applications."
8. Avago Application Note 1005, "Operational Considerations for LED Lamps and Display Devices."

Appendix A. Photometric Equipment Vendors

ADVANTEST AMERICA, INC.
Lincolnshire, IL
Tel: 708-634-2552

INTERNATIONAL LIGHT
Newbury, MA
Tel: 508-465-5923

ANDO CORPORATION
Rockville, MD
Tel: 301-294-3365

LMT
San Diego, CA 92138
Tel: 619-271-7474

ANRITSU AMERICA, INC.
Oakland, NJ
Tel: 201-337-1111

OPTRONIC LABS, INC.
Orlando, FL
Tel: 407-422-3171

BURLEIGH INSTRUMENTS, INC.
Fischers, NY
Tel: 716-924-9355

PHOTO RESEARCH
Chatsworth, CA
Tel: 818-341-5151

CUSTOM SAMPLE SYSTEM, INC.
St. Louis, MO
Tel: 314-962-4555

SPECTRA-PHYSICS OPTICS
CORP.
Mountain View, CA
Tel: 415-961-2550

EG&G GAMMA SCIENTIFIC, INC.

Tel: 619-279-8034

INSTRUMENTS SA, INC.
Edison, NJ
Tel: 908-494-8660

Appendix B. Radiometric and Photometric Guide¹

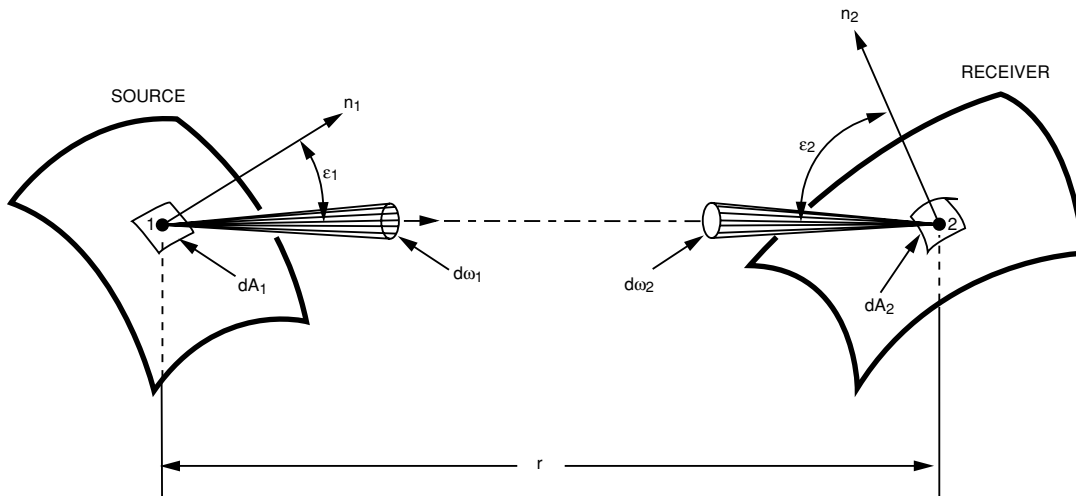

Figure B - 1. Illustration of explanatory notes given in Table B - 1 concerning basic radiometric quantities and units.

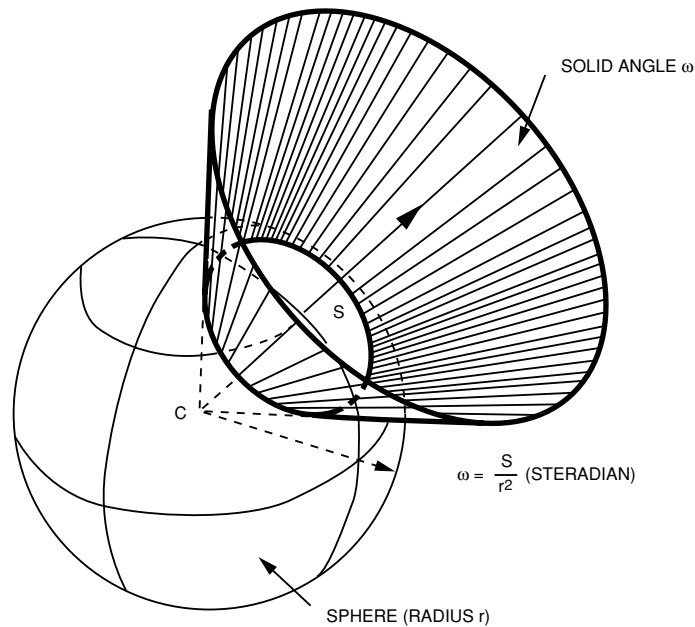

Figure B - 2. Illustration of a solid angle ω and its measurement in terms of the unit of solid angle, the steradian (sr). The apex of the solid angle is located at C . The solid angle cuts off an area S on the surface of a sphere centered at C and of radius r . The size of the solid angle ω is then given by the quotient of S over r^2 . In the case illustrated, ω is approximately equal to one steradian. The concept of solid angle is not confined to right-circular cones of the kind depicted in the illustration. Almost any shape of cone, generated by the straight lines emerging from the apex to the points of a closed curve, can represent a solid angle. If the closed curve is a polygon (e.g., a square), the cone and thus the solid angle takes on the shape of a pyramid.

Table B - 1. Basic Radiometric Quantities and Units

Term	Symbol	Defining Equation	Explanatory Notes and Formulae [see Fig B-1 and B-2]		Units
Radiant energy					J (joule)
Radiant power	P_e		$d^2P_e = L_e \frac{dA_1 \cos \varepsilon_1 dA_2 \cos \varepsilon_2}{r^2}$		$J \cdot s^{-1} = W(\text{watt})$
Radiant exitance	M_e	$M_e = \frac{dP_e}{dA_1}$	$dA_1 =$ surface element of source		$W \cdot m^{-2}$
Irradiance	E_e	$E_e = \frac{dP_e}{dA_2}$	$dA_2 =$ surface element of receiver		$W \cdot m^{-2}$
Radiant intensity	I_e	$I_e = \frac{dP_e}{d\omega_1}$	$d\omega_2 =$ element of solid angle with apex (1) at surface of source		$W \cdot sr^{-1}$
Radiance	L_e	$L_e = \frac{d^2P_e}{dA_1 \cos \varepsilon_1 d\omega_1}$ $= \frac{d^2E_e}{dA_2 \cos \varepsilon_2 d\omega_2}$ $= \frac{d(E_e)_n}{d\omega_2}$	$\varepsilon_1 =$ angle between given direction (1) - (2) and normal n_1 of dA_1 $\varepsilon_1 =$ angle between given direction (1) - (2) and normal n_2 of dA_2 $d\omega_2 =$ element of solid angle with apex (2) at surface of receiver	$dA_1 \cos \varepsilon_1 = dA_1$ orthogonally projected on plane perpendicular to given direction (1) - (2) $dA_2 \cos \varepsilon_1 = dA_2$ orthogonally projected on plane perpendicular to given direction (1) - (2) $d(^2E_e)_e = \frac{dE_e}{dA_2 \cos \varepsilon_1}$	$W \cdot m^{-2} \cdot sr^{-1}$
Solid angle	ω	$\omega = \frac{S}{r^2}$	$S =$ portion of sphere surface $r =$ radius of sphere, distance between (1) of dA_1 and (2) of dA_2	$d\omega_1 = \frac{dA_2 \cos \varepsilon_2}{r^2}$ $d\omega_2 = \frac{dA_1 \cos \varepsilon_1}{r^2}$	sr (steradian)
Frequency	ν				s^{-1}
Wavelength	λ	$\lambda = \frac{e}{\nu}$	$e =$ velocity of radiant energy in vacuo		m
Wavenumber	m	$m = \frac{1}{\lambda}$			m^{-1}

*In virtually all colorimetric applications, the unit for wavelength is the nanometer ($1 \text{ nm} = 10^{-9} \text{ m}$). In more vision oriented work, either wavelength in terms of nm or wavenumber in terms of cm^{-1} are used.

Note: If the spectral concentration of a radiometric quantity X_e is considered, it is usually designated by the name of the quantity preceded by the adjective *spectral*, and by the same symbol for the quantity with the subscript λ (or ν , or m): $X_{e\lambda} = dX_e/d\lambda$. For example, if X_e is radiant power, the spectral concentration of radiant power is simply referred to as spectral power and is denoted by $P_{e\lambda} = dP_e/d\lambda$.

Table B - 2. Basic Radiometric Quantities and Units

Term	Symbol	Defining Equation	Explanatory Notes	Units
Luminous flux (or power)	F_V (or F_V)	$F_V = K P_e$ $F_V = K_m \int \lambda P_e \lambda V(\lambda) d\lambda$	P_e : Radiant flux (W) K : Luminous efficacy ($\text{lm}\cdot\text{W}^{-1}$) K_m : Max. luminous efficacy ($683 \text{ lm}\cdot\text{W}^{-1}$)	lm
Luminous intensity	I_V	$I_V = \frac{dF_V}{d\omega_1}$	$d\omega_1$ = Element of solid angle with apex (1) at surface of source	cd ($\text{lm}\cdot\text{sr}^{-1}$)
Luminance	L_V	$L_V = \frac{d^2 F_V}{dA_1 \cos \varepsilon_1 d\omega_1}$ $= \frac{dI_V}{dA_1 \cos \varepsilon_1}$ $= \frac{d^2 E_V}{dA_2 \cos \varepsilon_2 d\omega_2}$ $= \frac{dE_{V,n}}{d\omega_2}$	dA_1 = Surface element of source ε_1 = angle between given direction (1) - (2) and normal n_1 of dA_1 $dA_1 \cos \varepsilon_1$ = dA orthogonally projected on plane perpendicular to given direction (1) - (2) $dE_{V,n}$ = Illuminance on dA_2 normal to the direction (1)-(2) $d\omega_2$ = Element of solid angle with apex (2) at surface of receiver	$\text{cd}\cdot\text{m}^{-2}$ ($\text{lm}\cdot\text{m}^{-2}\cdot\text{sr}^{-1}$)
Illuminance	E_C	$E = \frac{dF_V}{dA_2}$	dA_2 = Surface element of receiver	$\text{lm}\cdot\text{m}^{-2}$
Luminous exitance	M_V	$M = \frac{dF_V}{dA_1}$		$\text{lm}\cdot\text{m}^{-2}$
Luminous efficacy function	$K(\lambda)$	$K(\lambda) = K_m V(\lambda)$	$V(\lambda)$ = Relative photopic luminous efficiency function	

For product information and a complete list of distributors, please go to our web site: www.avagotech.com

Avago, Avago Technologies, and the A logo are trademarks of Avago Technologies, Limited in the United States and other countries.
Data subject to change. Copyright © 2007 Avago Technologies, Limited. All rights reserved.
5963-7073E - April 16, 2007

