

## Application Note 1060

### Contents

- Surface Mount LED Indicators
- Standard EIA Tape and Reel Packaging
- Moisture Barrier Envelope Packaging
- PC Board Pad Design
- Automatic Placement Equipment Considerations
- Solder Paste
- Reflow Soldering

### Surface Mount LED Indicators

Circuit board assemblies using surface mount technology (SMT) are now common and SMT LED indicators are being used on many of these SMT board assemblies. There are currently three basic types of Avago Technologies SMT LED indicator components:

- a. HLMP/A/T-6/7/P/Qxxxx domed and flat top subminiature lamps with formed leads:
  - Option 011 “gull wing” leads.
  - Option 021 “yoke” leads.
  - Option 031 “Z-bend” leads.
- b. ASMT-Cxxx and HSMx-Cxxx/Sxxx chip LEDs.
- c. HSMx-Axxx, ASMC-PRxx, ASMT-SWxx PLCC LEDs.

All these LED indicator components types may be mounted to a printed circuit (pc) board using automatic placement equipment and attached using a reflow solder process.

This application note provides information on how to successfully attach SMT LED indicators onto a pc board.

### Standard EIA Tape and Reel Packaging

SMT LED lamps are packaged tape and reel in accordance with EIA Standard 481, Taping of Surface Mount Components for Automatic Placement. Reel and tape dimensions conform to EIA standards with individual SMT LED lamps in the embossed carrier tape spaced on 4 mm (0.157 in.) centers. Detail tape and reel dimensions are stated in individual product D/S.

### Moisture Barrier Envelope Packaging

The optical grade materials used in SMT LED components absorb moisture directly from the air. Moisture absorbed in SMT LED components that have been reflow soldered to a pc board is typically on minor concern. However, moisture absorption in SMT LED components prior to reflow soldering is of serious concern. If moisture is absorbed by SMT LED components prior to soldering, the entrapped moisture turns to superheated steam during the solder process. The pressure of this superheated steam fractures the packages of the components causing catastrophic failure. Therefore, it is of vital importance to protect SMT LED components from absorbing moisture prior to soldering.

To protect the SMT LED components from moisture adsorption during shipping and handling, reels for SMT LED components may be packaged in moisture barrier envelopes, as illustrated in Figure 1.

Each envelope contains desiccant. To assure the moisture barrier seal, it is important to protect these envelopes from being punctured by sharp objects such as staples. Once opened, SMT LED components should be handled in accordance with the recommendations for their appropriate moisture sensitivity classification. The Joint Industry Standard J-STD-020, Moisture/Reflow Sensitivity Classification for Plastic Integrated Circuit Surface Mount Devices, issued by the EIA/JEDEC JC-14.1 Committee establishes the necessary handling recommendations for each moisture sensitivity classification. For information on the appropriate moisture sensitivity classification of Avago Technologies SMT LED components, please refer to application note AN 5305.

### PC Board Land Pattern Design

The design of the pc board metallic attachment pads (land pattern) is important to assure both positions on and attachment to an SMT board assembly. Solder coated one ounce copper pads are best for reflow soldering.

## PC Board Pad Design Considerations and Device-to-Device pad Alignment

Placing an SMT LED component on the pc board so its axis is oriented perpendicular to the long dimension side of the board, as shown in Figure 2, will tend to reduce stress on the device during temperature cycling. Placing the axis of an SMT LED component parallel to the long dimension side of the pc board will increase the probability of defects. The proper design of pc board attachment pads, as illustrated in Figure 3, will increase the probability of proper reflow solder connections. Recommended pad size should be adopted fully as it has been tested and verified. Accurate placement of the SMT components onto the pc board attachment pads enhances the probability of proper alignment after solder freeze. When the pc board pads are the correct size in relation to the

device leads, the SMT LED components will self align with respect to the pads, assisted by the capillary attraction/wetting forces of the hot liquid solder. PC board traces should connect to the center of each attachment pad. Traces that connect to the outer edges of pads impart a torque to the SMT LED component which contributes to skewing and off centering problems. Adjacent attachment pads for SMT LED components electrically connected in series should be connected with a trace that is a maximum of 0.20 inches wide. Solder resist masking should be well defined around the perimeter of the attachment pads, without voids or smears over the pads that will inhibit the formation of good solder connections.

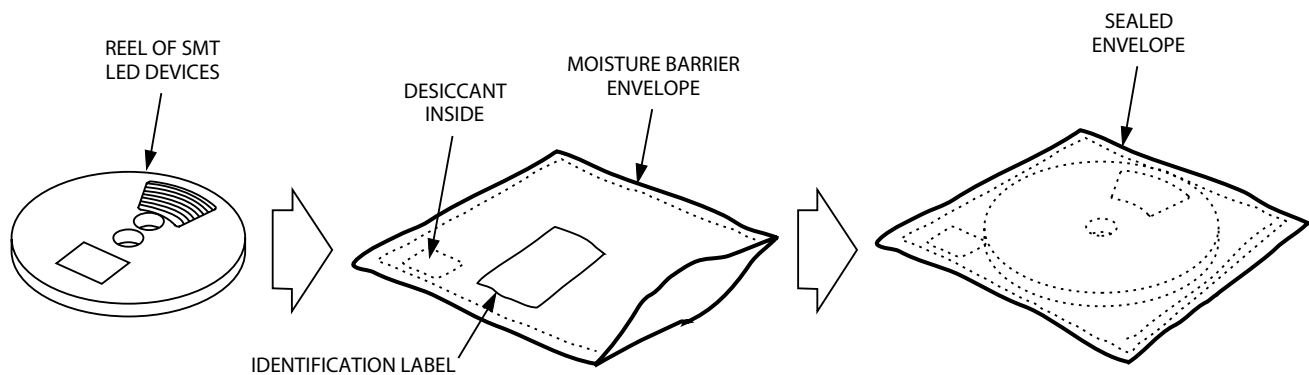

Figure 1. Moisture Barrier Envelope Packaging for SMT LED Indicator Components.

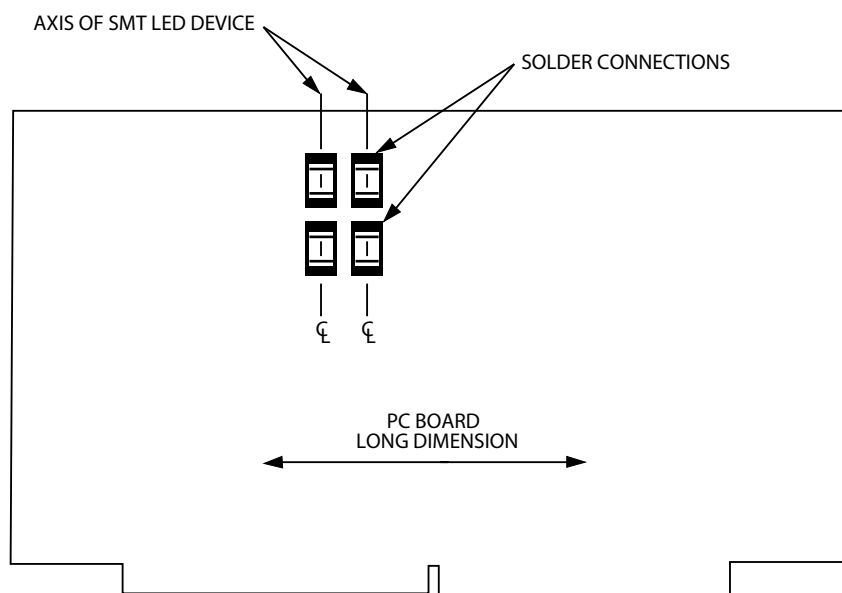
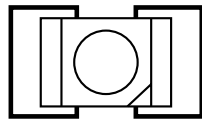
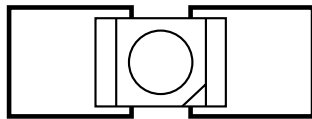

Figure 2. Recommended Orientation of SMT LED Components on PC Boards for Minimum Stress.



CORRECT  
PAD SIZE



PADS  
TOO LONG

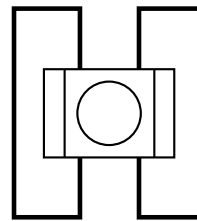

PADS TOO WIDE

**PC BOARD ATTACHMENT PAD SHAPES**

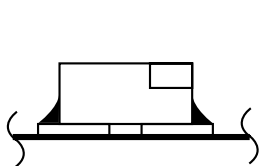

SMT LED IS  
SELF CENTERED

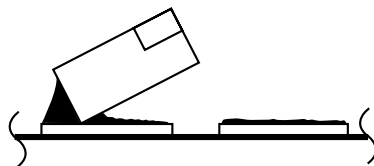

TOMBSTONING  
SMT LED

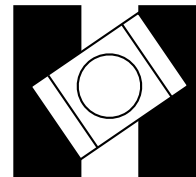

SKEWED SMT LED

**REFLOW SOLDERED SMT LED**

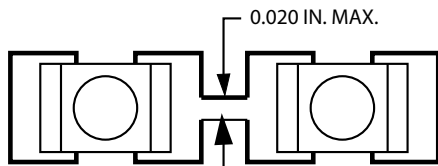

GOOD DESIGN

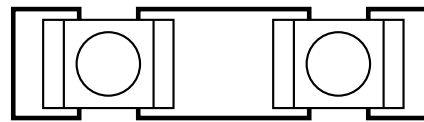

INFERIOR DESIGN

**PADS IN A SERIES CONNECTION**

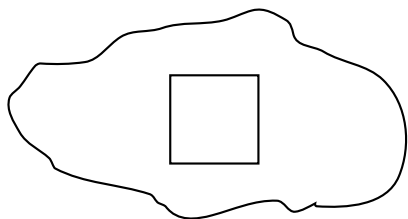

GOOD SOLDER  
MASKING

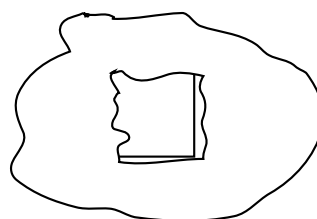

UNACCEPTABLE  
SOLDER MASKING

**SOLDER MASKING**

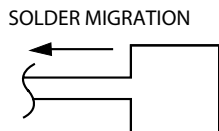

GOOD TRACE  
CONNECTION

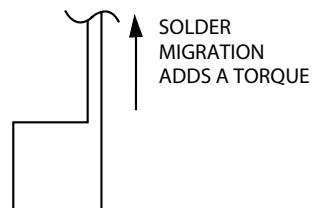

POOR TRACE  
CONNECTION

SOLDER  
MIGRATION  
ADDS A TORQUE

**CIRCUIT TRACE-TO-PAD CONNECTIONS**

Figure 3. PCB Land Pattern Design Consideration for SMT LED Components. Pad Dimensions should not exceed 0.20 mm (0.008 in.) of recommended size.

## Automatic Placement Equipment Considerations

The subminiature Option 011 "gull wing" lead components are mounted upright in the embossed cavities of the carrier tape. A hole is located in the bottom of each embossed cavity to allow an automatic pick and place machine to utilize a push pin to assist in device removal from the carrier tape.

The subminiature Option 021 "yoke" lead and Option 031 "Z-bend" lead components are mounted top side down in the carrier tape. Since the round domes of the device packages are pointing down, the bottoms of the embossed cavities do not have push-pin holes while the carrier tape for the chip LED and PLCC LED do have push-pin holes in the bottom of the embossed cavities. However, the push-pin action of the automatic pick and place machine must be disabled when picking these devices from the carrier tape.

The top side surfaces of SMT LED components, as they sit in the embossed cavities of the carrier tape, present to a pick-up tool either a surface that is not perfectly flat or a round dome. As a result, the typical stainless steel vacuum pick-up tool may not form a vacuum seal with the device package and thus may not be able to pick it out of the embossed cavity. Figure 4 shows a flat soft tip pick-up tool for picking up surface mount LED components. The soft tip pick-up tool is usually made of nylon or other soft plastic. For picking up subminiature lamp Option 011 "gull wing" domed components and lensed PLCC4, the end of the soft tip should be contoured concave to fit snugly over the dome of that particular SMT LED device to form a vacuum seal.

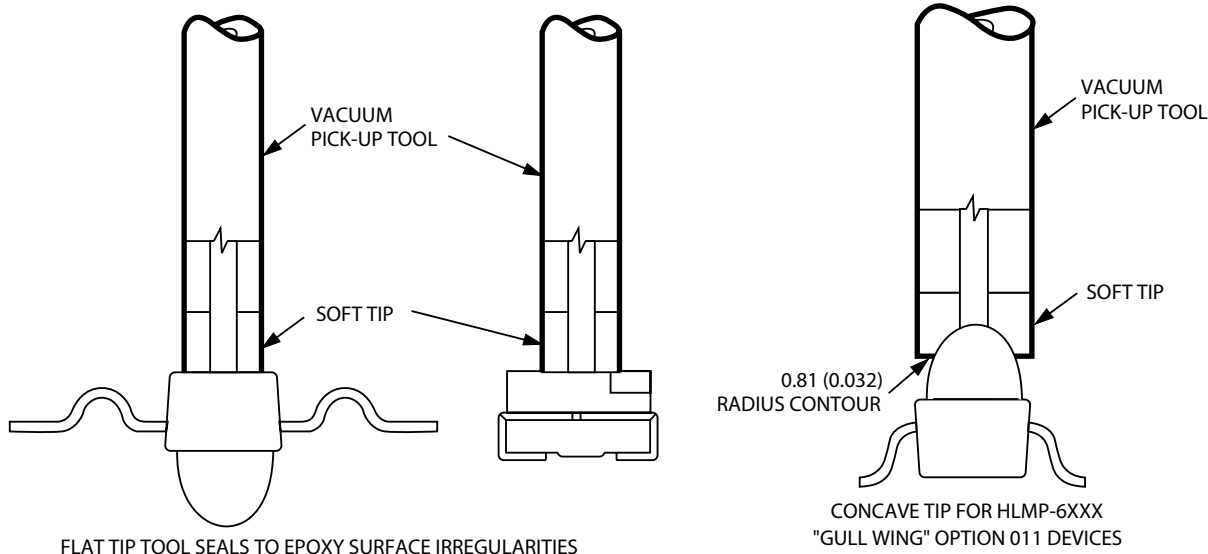

Figure 4. Soft Tip Vacuum Pick-up Tool for Extracting SMT LED Components from Embossed Carrier Tape.

## Solder Paste

For best results, an SN63 eutectic solder paste, liquidus at +183°C (+361°F), should be used. SN62 solder paste containing 2% silver, liquidus at +189 °C (+372 °F), may be used with the chip LED devices, with the advantage of obtaining stronger solder connections, but higher cost. The solder paste should contain 85 to 95% by weight (38 to 67% by volume) solder ball powder. The solder paste should be stable over time after deposition on the pc board. After deposition, a well formulated paste will not degrade or change reflow characteristics due to moisture absorption and oxidation over time period of 12 hours at room temperature. Refrigerated storage of unused solder paste extends shelf life, typically beyond three months at 0 °C (+32 °F). The solder paste may be deposited onto pc board pads by either screen printing, using a stencil, or by syringe dispensing.

The solder paste should cover the pad with a smooth, even contour, without voids. Voids in the deposited solder paste may be due to contamination or oxidation on the pc board metal pads, improper solder paste viscosity, clogged openings in the screen mesh, or a "dirty" syringe dispensing tool. Since solder paste will wick outward by 0.004 to 0.005 inches, the deposited paste should cover the attachment pas just short by this amount.

The PLCC SMT LEDs have been qualified with solder pastes below based on reflow profiles as stated in the following section:

- i. Leaded soldering system
  - a. Tamura RMA-10-61A(M1)
  - b. Tamura RMA-23-45CX
  - c. Multicore CR37 63S4 AGS
- ii. Lead free soldering system
  - a. Multicore 97SC LF310 AGS
  - b. Indium NC-SMQ230

## Reflow Soldering

All SMT LED components may be reflow soldered using a convective IR process. A convective IR process uses middle to long infrared wavelengths (approximately 4000 to 6200 nanometers). Approximately 65% of the energy is used to heat the air in the reflow chamber (convective heating) and 35% of the energy directly heats the pc board and components (radiative heating). Some systems are forced hot air systems with a dual chamber design, where one chamber has IR heaters to heat the air which is then blown over the pc board assemblies located in a second chamber. In these systems, heating is 100% convective. The pc board and components are uniformly heated to achieve reliable solder connections. The thermal stresses experienced by SMT LED components are minimized in a convective thermal environment.

Figure 5 and 6 are straight-line representatives of a nominal temperature profile for a convective IR reflow solder process. The temperature profile is divided into four process zones. The temperatures are measured at the component to pc board connections.

### Process Zone P1

In process zone P1, the PCB and SMT LED components are heated to an elevated temperature to activate the flux in the solder paste. The temperature ramp up rate, R1, is limited to +3°C per second to allow for even heating of both the pc board and the SMT LED components.

### Process Zone P2

Process zone P2 should be of sufficient time duration to dry the solder paste. The temperature is raised to a level just below the liquidus point of the solder, usually +170°C (+338°F) for leaded IR reflow solder process and +200°C (+392°F) for lead free reflow solder process.

### Process Zone P3

Process zone P3 is the solder reflow zone. In zone P3, the temperature is quickly raised above the liquidus point of solder for optimum results. The dwell time above the liquidus point of solder is important to ensure proper coalescing of these solder balls into liquid solder and the formation of good solder connections. Too long a dwell time will cause the intermetallic growth within the solder connections becomes excessive, resulting in the formation of weak and unreliable connections. Table 1 and 2 below show the recommended solder reflow conditions for both SnPb and SnAgCu solder paste system.

### Process Zone P4

Process zone P4 is the cool down after solder freeze. The cool down rate from the liquidus point of the solder to +25°C (+77°F) should not exceed -3°C/s (-5.4°F/s) for leaded soldering and -6°C/s (-10.8°F/s) maximum. This limitation is necessary to allow the pc board and SMT LED devices to change dimensions evenly, putting minimal stresses on the SMT LED device packages.

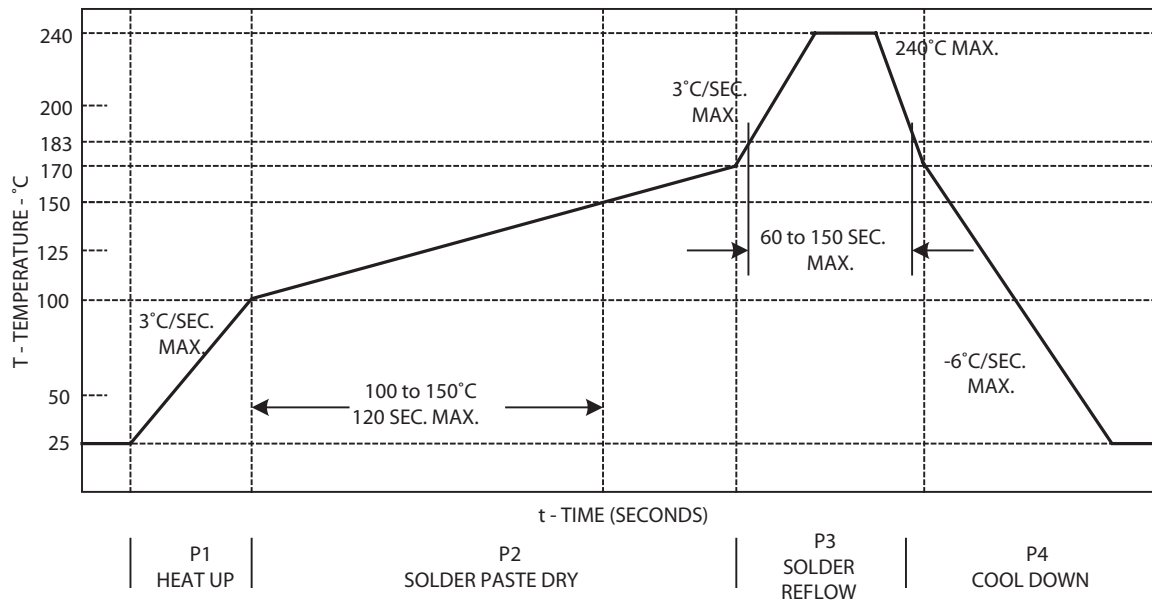
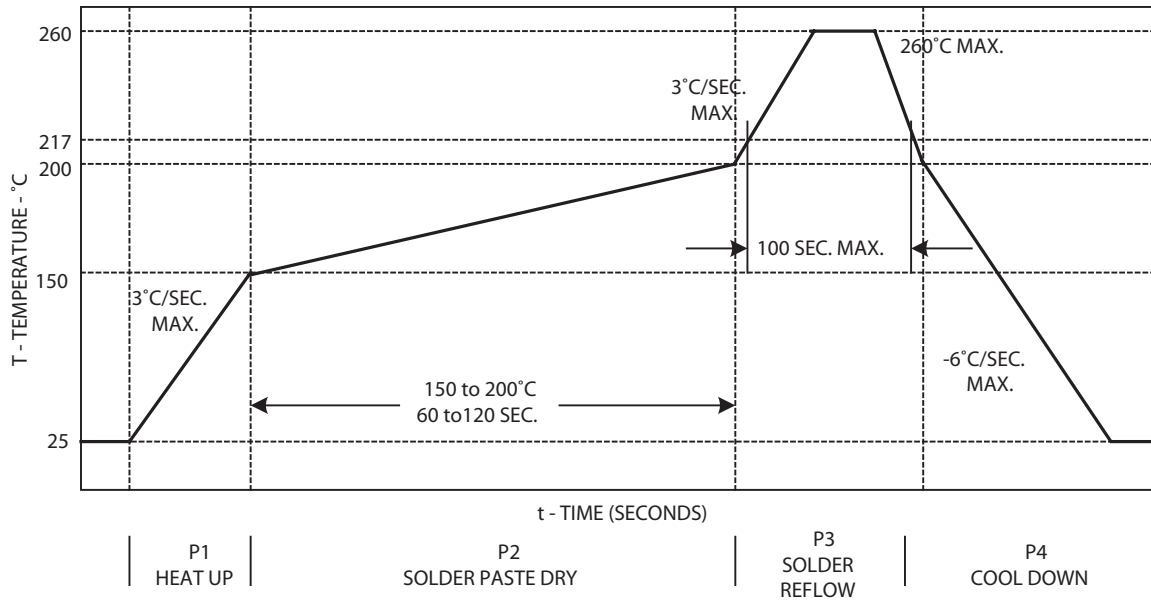

Figure 5. Temperature Profile for Nominal Convective IR Reflow Solder Process.

Note:

This soldering profile outlines the general process during soldering and does not depict actual recommended soldering profile. For actual recommended soldering profile please refer to their respective data or option sheets.



**Figure 6. Recommended Sample Lead-Free Temperature Profile IR Reflow Solder Process.**

**Notes:**

This soldering profile outlines the general process during soldering and does not depict actual recommended soldering profile. For actual recommended soldering profile please refer to their respective data or option sheets.

For product information and a complete list of distributors, please go to our web site: [www.avagotech.com](http://www.avagotech.com)

Avago, Avago Technologies, and the A logo are trademarks of Avago Technologies, Limited in the United States and other countries. Data subject to change. Copyright © 2006 Avago Technologies Limited. All rights reserved. Obsoletes 5989-2268EN AV01-0654EN - November 15, 2006

