

# CAT4237EVAL2 Evaluation Board for CAT4237 High Voltage White LED Driver



Denisa Stefan, Applications Engineering Manager  
denisa.stefan@catsemi.com

## INTRODUCTION

This document describes the CAT4237EVAL2 Evaluation Board for the Catalyst Semiconductor CAT4237 white LED driver. The functionality and major parameters of the CAT4237 can be evaluated with the CAT4237EVAL2 board.

The CAT4237 is a high voltage CMOS constant-current DC/DC converter that has been designed to drive with high efficiency white or other high brightness LEDs. The high-voltage output stage allows driving up to 8 white LEDs in series. A single external resistor sets the LED current between 5mA and 30mA. LED current can be adjusted using either a pulse width modulated (PWM) signal or a DC voltage. Detailed descriptions and electrical characteristics are in the CAT4237 data sheet.

## CAT4237EVAL2 BOARD HARDWARE

The evaluation board contains a CAT4237 DC-DC boost converter and an array of white LEDs. As configured, the board circuit is set to drive up to 8 white LEDs in series. The user can chose to connect

the CAT4237 output to the LEDs string available on board or to an external LEDs string from an application.

The board provides also the option to connect a different number of LEDs available on board, 6, 7 or 8, using a jumper shunt for one of the J2 to J4 connectors. The board schematic is shown in Figure 1.

The board is powered from an external voltage applied to the VIN (T1) pad. The circuit is delivered with the jumper shunt on the J4 connector, which connects the 8 LEDs string available on board to the CAT4237 output. The user can move the jumper to other connector, J2 or J3, if they desire to connect a different number of LEDs (6 or 7 LEDs).

The user can connect their own white LEDs between VOUT (T7) and LED (T10) test points, with no jumper shunt set to any of J2 to J4 connectors.

The LED current is set through the external resistors connected to the FB pin (R1, R2). Using the variable resistor R2, the LED current can be set from 3mA to 30mA. Most white LEDs are driven at a nominal current between 15mA and 20mA to ensure a pure "white" light.

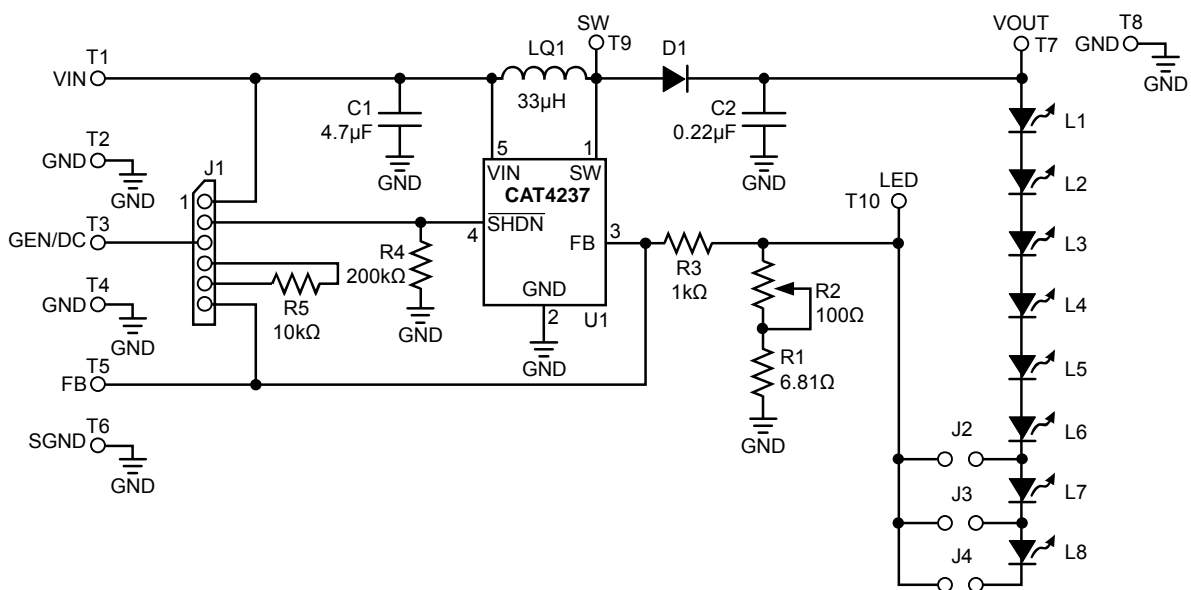

Figure 1. CAT4237EVAL2 Board Schematic

## CAT4237EVAL2 Evaluation Board

The board also demonstrates the CAT4237 shutdown mode and LED brightness control by using an external PWM signal or DC voltage. Resistors R3 and R5 (R5 – soldered on board by the user) are used to adjust the LED current using the dimming control with an external applied DC voltage on the FB pin. The ON/OFF operation and dimming control can be selected using the jumper options for the J1 connector.

Test points T1 to T10 are available to apply the external voltages/signal generator or to measure the output voltages / signals provided by CAT4237.

The component placement and the board picture are shown in Figure 2. Table 1 presents the component list for this evaluation board.

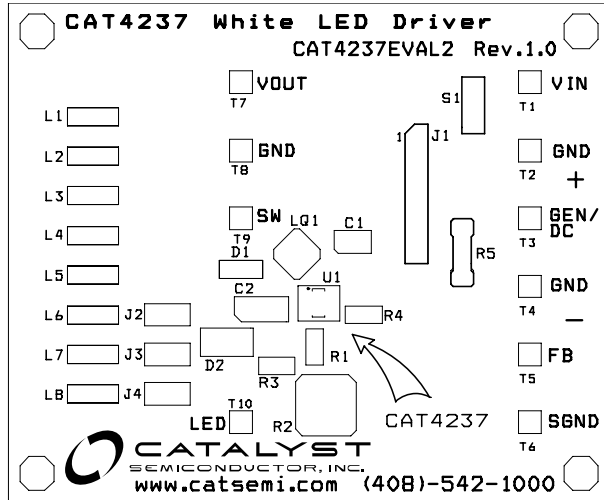

Figure 2. CAT4237EVAL2 Board

Table 1. CAT4237EVAL2 Eval Board List of Components

Name	Manufacturer	Description	Part Number	Units
U1	Catalyst	CMOS White LED Driver, TSOT23 - 5-pin	CAT4237TSI	1
C1	Taiyo Yuden (or Panasonic)	Ceramic Capacitor 4.7 $\mu$ F/6.3V, X5R, Size 0805	JMK212BJ475 (or Digi-Key PCC2315CT-ND)	1
C2	Taiyo Yuden (or Kemet)	Ceramic Capacitor 0.22 $\mu$ F/50V, X5R(X7R)	(C1206C224K5RACTU)	1
L1	Sumida (or TDK)	Inductor 33 $\mu$ H, low DCR, high current	CDRH3D16-330 or VLCF4018T-330MR42-2	1
D1	Central	Schottky Diode, Low VF, high current, SOD-323	CMDSH05-4	1
R1	Yageo	SMT Resistor 1/16W, 6.81 $\Omega$ , 0603	Digi-Key 311-6.81HCT-ND	1
R2	Bourns	Trimmer Pot, 1/4", 100 $\Omega$	3329W-101-ND (or equiv)	1
R3	Yageo	SMT Resistor 1/16W, 1.0k $\Omega$ , 0603	Digi-Key 311-1.0KHCT-ND	1
R4	Yageo	SMT Resistor 1/16W, 200 $\Omega$ , 0603	Digi-Key 311-200KHCT-ND	1
R5	Yageo	Metal Film Resistor 1/16W, 10k $\Omega$ (not soldered on board)	Digi-Key 10.0KXBK-ND	1
L1 to L8	Nichia	White LED, SMT	NSCW100 or NSCW335	8
J1		6-pin Header Connector, 0.1", Single Strip"	Digi-Key S1012-06-ND (or equiv)	1
J2 to J4		2-pin Header Connector, 0.1", Single Strip"	Digi-Key S1012-02-ND (or equiv)	3
T1 to T10	Mil-Max	Pin Receptacle (Test Points)	#0149-0-15-01-30-14-04-0 (or equiv)	10

## CAT4237 EVALUATION

The CAT4237EVAL2 gives the user a way to evaluate the CAT4237 in a typical application of driving multiple LEDs.

The user can connect 6 to 8 LEDs in series to the CAT4237 output, using the jumper options for J2, J3 or J4 header-pin connectors.

The following steps are an example of how the user can evaluate the CAT4237 white LED driver:

### 1) DRIVING 8 LEDs IN SERIES AND SHUTDOWN MODE

- a) Connect the 8-LEDs string to the CAT4237 output using a jumper shunt on J4 header-pin connector (J2, J3 not jumpered).
- b) Set the R2 potentiometer to the middle position.
- c) Apply the external voltage supply,  $V_{EXT}$  ( $3.0V < V_{IN} < 5V$ ) between VIN (T1) and GND (T2).
- d) The CAT4237 is in the shutdown mode (SHDN pin is connected to GND) if the J1 connector is not jumpered.
  - Connect a current meter between VEXT and VIN pad to measure the shutdown current:  $I_{SD} \ll 1\mu A$
  - In this mode of operation the LEDs are disconnected from the output: LEDs are OFF
- e) Connect SHDN pin of the CAT4237 to VIN using a jumper shunt between Pin #1 and Pin #2 of J1 connector
  - Observe that LEDs are ON.

### 2) LED CURRENT EVALUATION

#### a) Programming LED current

LED current is programmed using the external resistors,  $R_{SET} = R1 + R2$ , connected to the FB pin. The voltage at the FB pin is internally regulated to the value  $V_{FB} = 300mV \pm 15 mV$ .

The current into the LED pin can be set according to the following equation:

$$I_{LED} (mA) = V_{FB} (mV) / R_{SET}(\Omega) = V_{FB} / (R1 + R2).$$

- Set the input voltage: ex.  $V_{IN} = 3.6V$ .
- Disconnect the jumper from the J4 connector and insert a current meter between these pins to monitor the LED current, ILED.
- Rotate the potentiometer R2 and observe the ILED value on the current meter. The current can be adjusted between 3mA and 30mA, approximately. Various LED current values and the associated RSET values are listed below:

$I_{LED} (mA)$	5	10	15	20	25	30
$R_{SET} (\Omega)$	59	29.8	20	15	12	10

- Monitor the voltage on FB (T5), VOUT (T7), and SW (T9).
- Verify the internal switch frequency ( $f_{SW} = 1.0MHz$  – typically) using a scope probe connected on SW (T9) test point (GND = T8).

Figure 3 shows the internal switch output,  $V_{SW}$  (DC coupled, 10V/div) and the regulated voltage on FB pin,  $V_{FB}$  (DC, 500mV/div) for  $V_{IN} = 3.6V$ ,  $I_{LED} = 20 mA$ , 8 LEDs in series connected to the CAT4237 output.

Figure 4 shows the  $V_{OUT}$  (CH2, AC coupled at 100mV/div) against  $V_{SW}$  (CH1).

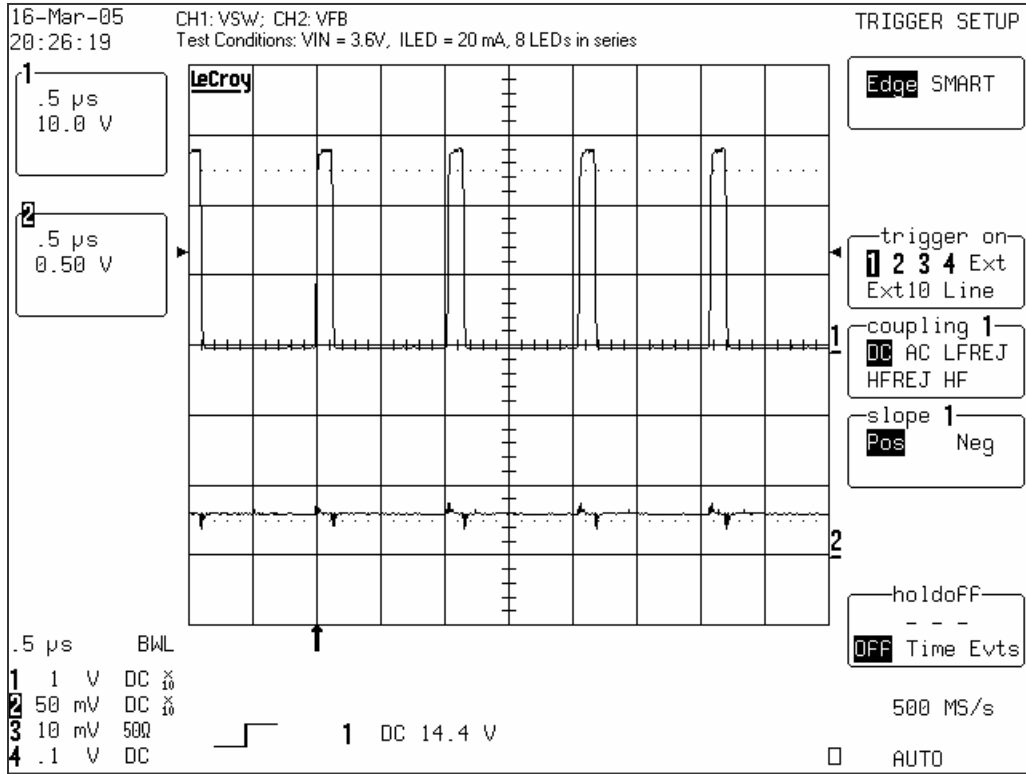

Figure 3. Internal Switch Output and Regulated  $V_{FB}$  Voltage Waveforms ( $I_{LED} = 20\text{mA}$ ,  $V_{IN} = 3.6\text{V}$ )

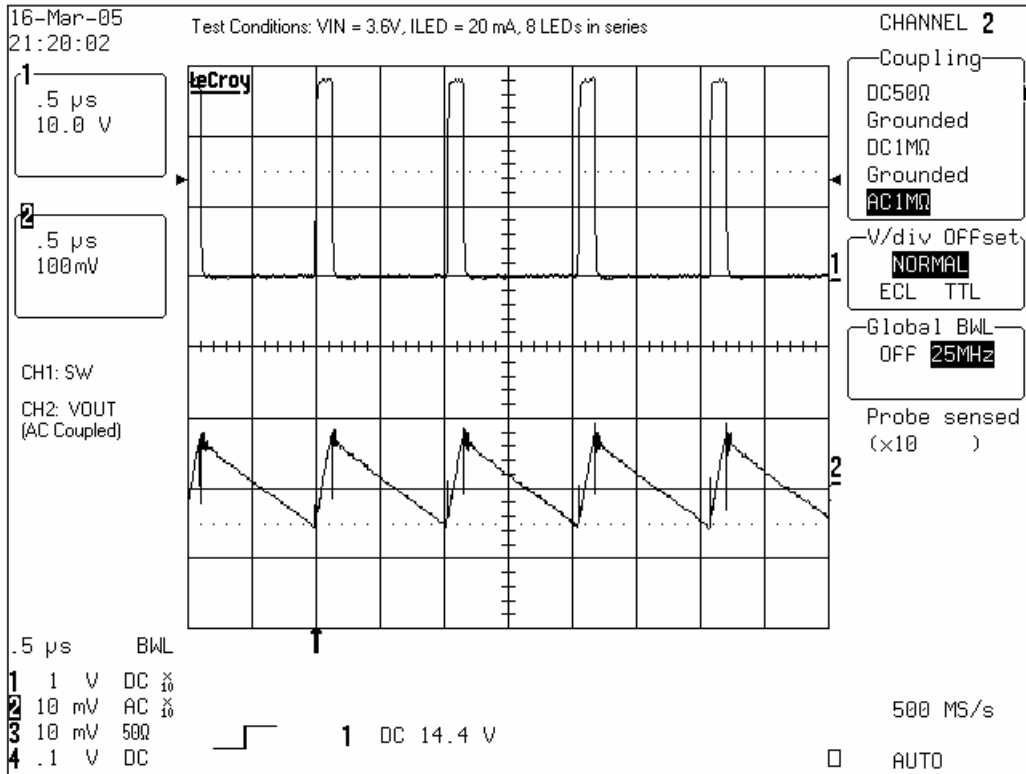
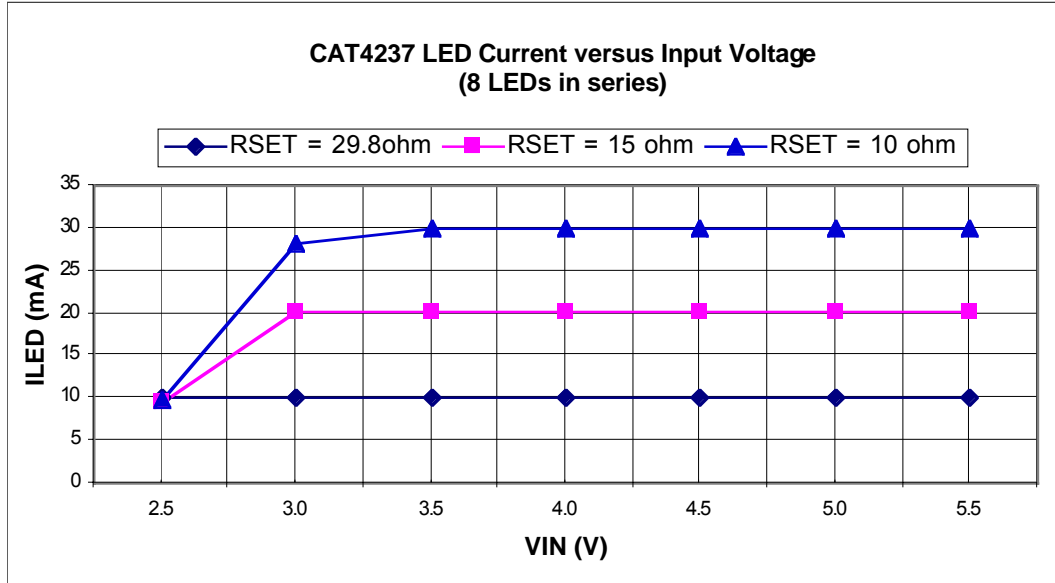

Figure 4. Internal Switch and Output Voltage Waveforms ( $V_{IN} = 3.6\text{V}$ ,  $I_{LED} = 20\text{mA}$ )

**b) Evaluating LED current regulation versus the input voltage, VIN.**

- Set the  $I_{LED}$  to a programmed value using the R2 potentiometer (i.e. 10mA, 20mA, 30mA for  $V_{IN} = 3.6V$ )
- For any  $I_{LED}$  value vary the  $V_{IN}$  voltage between 2.5V and 5.5V
- Observe the value of  $I_{LED}$  measured by the current meter and  $V_{FB}$  using a voltmeter. Figure 5 presents the  $I_{LED}$  current versus  $V_{IN}$ . Figure 6 shows the CAT4237 FB voltage versus input voltage.



Note:  $R_{SET} = R1 + R2$

**Figure 5. LED Current Line Regulation**

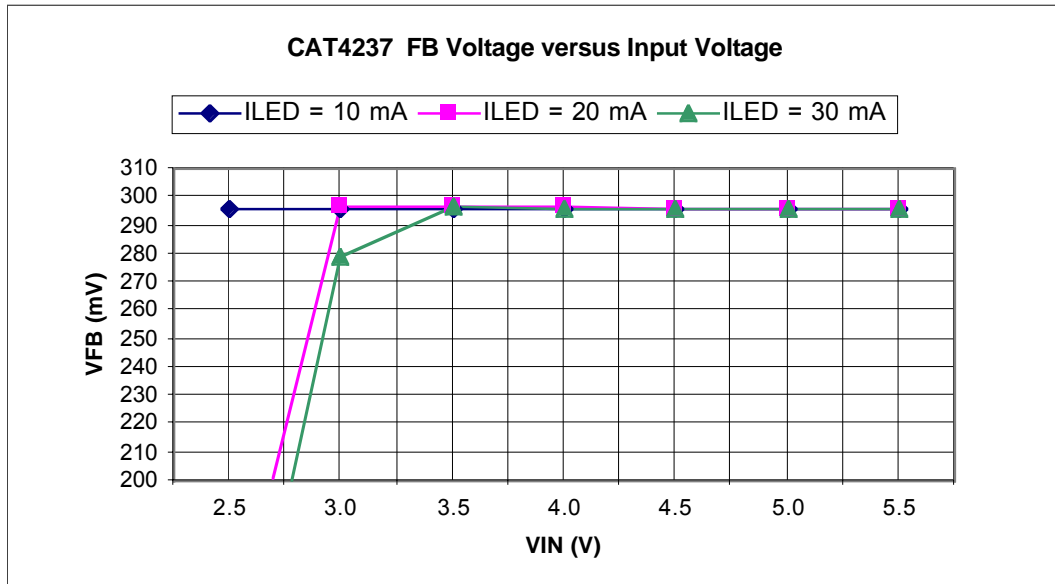

**Figure 6. V<sub>FB</sub> Voltage Line Regulation**

### 3) EFFICIENCY EVALUATION

The efficiency is evaluated according to the following equation:

$$\text{Efficiency (\%)} = (I_{\text{LED}} \times \Sigma V_{\text{Fi}}) / (I_{\text{IN}} \times V_{\text{IN}}) \times 100,$$

where  $\Sigma V_{\text{Fi}} = V_{\text{OUT}} - V_{\text{LED}}$ ,  $V_{\text{LED}}$  is the voltage measured at LED (T10) test point.

- Insert a current meter, CM1, between input supply voltage,  $V_{\text{EXT}}$ , and  $V_{\text{IN}}$  pad to monitor the input current,  $I_{\text{IN}}$ .
- Set the input voltage for  $V_{\text{IN}} = 3.6\text{V}$
- Adjust the R2 potentiometer for the  $I_{\text{LED}} = 5\text{mA}$ . Observe the  $I_{\text{LED}}$  current on the meter, CM2, inserted between Pin #1 and Pin #2 of J4 connector.
- Measure the  $I_{\text{IN}}$  current on CM1
- Monitor the output voltage on  $V_{\text{OUT}}$  (T7) and  $V_{\text{LED}}$  voltage on LED (T10) test points.
- Repeat steps c) to e) for  $I_{\text{LED}} = 10\text{mA}$ ,  $15\text{mA}$ ,  $20\text{mA}$ ,  $25\text{mA}$  and  $30\text{mA}$ .

Figure 7 presents the efficiency measured for 2 values of input voltage,  $V_{\text{IN}} = 3.6\text{V}$  and  $V_{\text{IN}} = 4.2\text{V}$ , with 8 LEDs in series connected to the CAT4237 output. The efficiency is over 80% for the recommended LED current levels of  $15\text{mA}$  to  $20\text{mA}$  that ensure a pure "white" light.

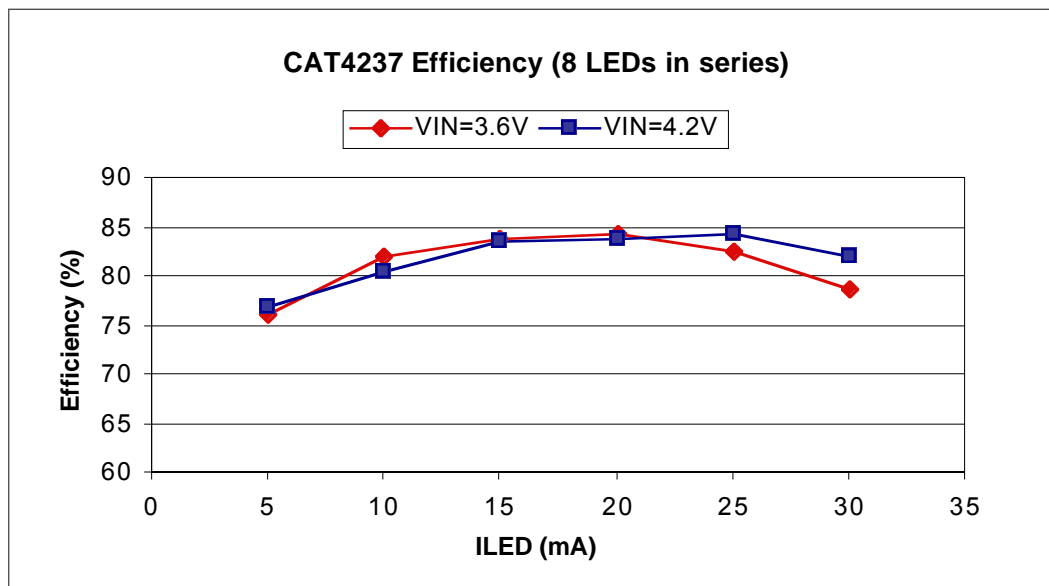

Figure 7. CAT4237 Efficiency Driving 8 LEDs in Series

### 4) DIMMING CONTROL

The LED brightness control can be accomplished by using a PWM signal applied to the SHDN pin or to the FB pin. The other method is to use a variable DC voltage applied through a resistor to FB pin.

#### a) Dimming using a PWM signal on the SHDN pin.

The LEDs are turned off and on at the PWM frequency. The average current changes with the duty cycle. Increasing the duty cycle will increase the LED brightness. The peak current value sets the light spectrum.

- Connect the jumper shunt between Pin #2 and Pin #3 of the J1 connector.
- Apply a pulse signal generator to the GEN/DC (T3) pad: Frequency = 200Hz to 2kHz; Amplitude 0V to 3V;  $V_{\text{IN}} = 3.6\text{V}$ .

- Modify the duty cycle between 0% and 100%.
- Observe the average current through LEDs measured by a current meter inserted at J4 connector. For 0% duty cycle, the  $I_{LED}$  will be off ( $I_{LED} = 0mA$ ); At the maximum duty cycle, the LED will be driven at the maximum current set by the R2 potentiometer.
- Monitor the FB voltage compared with the PWM signal applied on SHDN input.

Figure 8 shows the voltage monitored on the FB pin,  $V_{FB}$  (CH2) using a PWM signal applied to the SHDN pin (CH1). The frequency of the PWM signal is 2 KHz approximately.

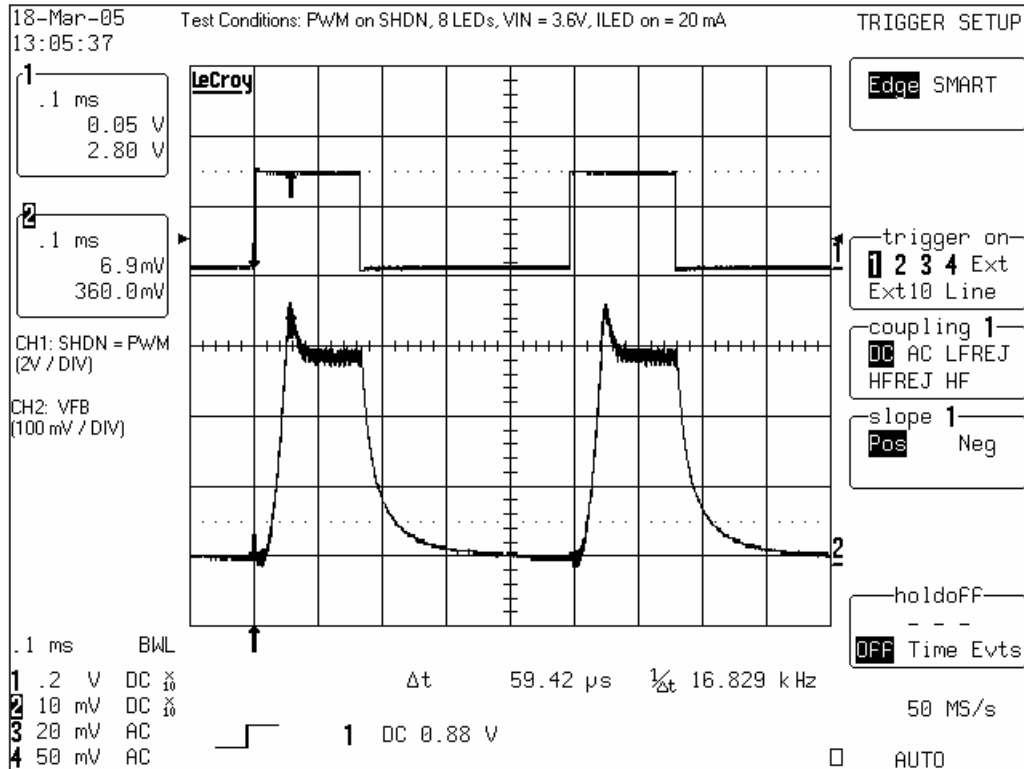

Figure 8. FB Voltage Waveform with PWM

#### b) Dimming using a DC voltage applied to the FB pin

A variable external DC voltage is applied on FB pin to adjust the LED current. As the DC voltage is increased, the voltage drop on resistor R3 is increased and the voltage drop on  $R_{SET} = R1 + R2$  is decreased, thus the LED current decreases. The external DC voltage is applied to FB pin through a series resistor, R5, which sets the maximum DC voltage.

Also, a filtered PWM signal can be considered as a variable DC voltage.

- Connect the SHDN pin to VIN: jumper shunt between Pin #1 and Pin #2 of J1 connector.
- Set the  $I_{LED}$  current (i.e.  $I_{LED MAX} = 20 mA$ )
- Connect the GEN/DC to FB pin through R5 resistor using one jumper between Pin #3 and Pin #4 and another jumper shunt between Pin #5 and Pin #6 of J1 connector.
- Apply the variable DC voltage between GEN/DC (T3) and GND (T4).
- Increase the DC voltage value (from 0V to  $V_{MAX} = 3.2V$ ).
- Observe the  $I_{LED}$  current decreases from the  $I_{LED MAX}$  (20mA – previous set) to  $I_{LED MIN}$  (0mA for  $V_{MAX} = 3.2V$  with the existing resistors values,  $R3 = 1k\Omega$ ,  $R5 = 10k\Omega$ ).

## REVISION HISTORY

Date	Rev.	Comments
04/05/2005	A	Initial Issue
07/14/2005	B	Update for CAT4237EVAL2, 2 <sup>nd</sup> version of evaluation board
02/14/2008	C	Updated Table 1. CAT4237EVAL2 Eval Board List of Components Add MD- to document number

---

### Copyrights, Trademarks and Patents

© Catalyst Semiconductor, Inc.

Trademarks and registered trademarks of Catalyst Semiconductor include each of the following:

Adaptive Analog™, Beyond Memory™, DPP™, EZDim™, LDD™, MiniPot™, Quad-Mode™ and Quantum Charge Programmable™

Catalyst Semiconductor has been issued U.S. and foreign patents and has patent applications pending that protect its products.

*CATALYST SEMICONDUCTOR MAKES NO WARRANTY, REPRESENTATION OR GUARANTEE, EXPRESS OR IMPLIED, REGARDING THE SUITABILITY OF ITS PRODUCTS FOR ANY PARTICULAR PURPOSE, NOR THAT THE USE OF ITS PRODUCTS WILL NOT INFRINGE ITS INTELLECTUAL PROPERTY RIGHTS OR THE RIGHTS OF THIRD PARTIES WITH RESPECT TO ANY PARTICULAR USE OR APPLICATION AND SPECIFICALLY DISCLAIMS ANY AND ALL LIABILITY ARISING OUT OF ANY SUCH USE OR APPLICATION, INCLUDING BUT NOT LIMITED TO, CONSEQUENTIAL OR INCIDENTAL DAMAGES.*

Catalyst Semiconductor products are not designed, intended, or authorized for use as components in systems intended for surgical implant into the body, or other applications intended to support or sustain life, or for any other application in which the failure of the Catalyst Semiconductor product could create a situation where personal injury or death may occur.

Catalyst Semiconductor reserves the right to make changes to or discontinue any product or service described herein without notice. Products with data sheets labeled "Advance Information" or "Preliminary" and other products described herein may not be in production or offered for sale.

Catalyst Semiconductor advises customers to obtain the current version of the relevant product information before placing orders. Circuit diagrams illustrate typical semiconductor applications and may not be complete.

---



Catalyst Semiconductor, Inc.  
Corporate Headquarters  
2975 Stender Way  
Santa Clara, CA 95054  
Phone: 408.542.1000  
Fax: 408.542.1200  
0Hwww.catsemi.com

Document No: MD-6041  
Revision: C  
Issue date: 02/14/08