



CAT3200DB1 Demonstration Board for the CAT3200 DC - DC Converter

*Denisa Stefan, Applications Engineer
denisa.stefan@catsemi.com*

1. INTRODUCTION

This document describes the CAT3200DB1 Demonstration Board for the CAT3200 charge-pump, DC-to-DC converter. This board shows a typical application of the CAT3200-5 driving multiple white LEDs in parallel.

The CAT3200 and CAT3200-5 are DC-to-DC boost converters that deliver a regulated output voltage. The CAT3200-5 has a fixed 5V output, and the CAT3200 has an adjustable output. These devices provide a regulated output voltage from a 2.7 to 4.5V input voltage with output loads up to 100 mA.

A shutdown control input allows the device to be placed in a low-power mode. In this mode of operation the load is disconnected from the input supply voltage and quiescent current is less than 1µA.

Detailed descriptions and electrical characteristics of the CAT3200/3200-5 are in the device data sheet.

2. CAT3200DB1 BOARD HARDWARE AND OPERATION

The demonstration board uses the CAT3200-5 to drive six white LEDs in parallel from a 3V battery. The board schematic is shown in Figure 1.

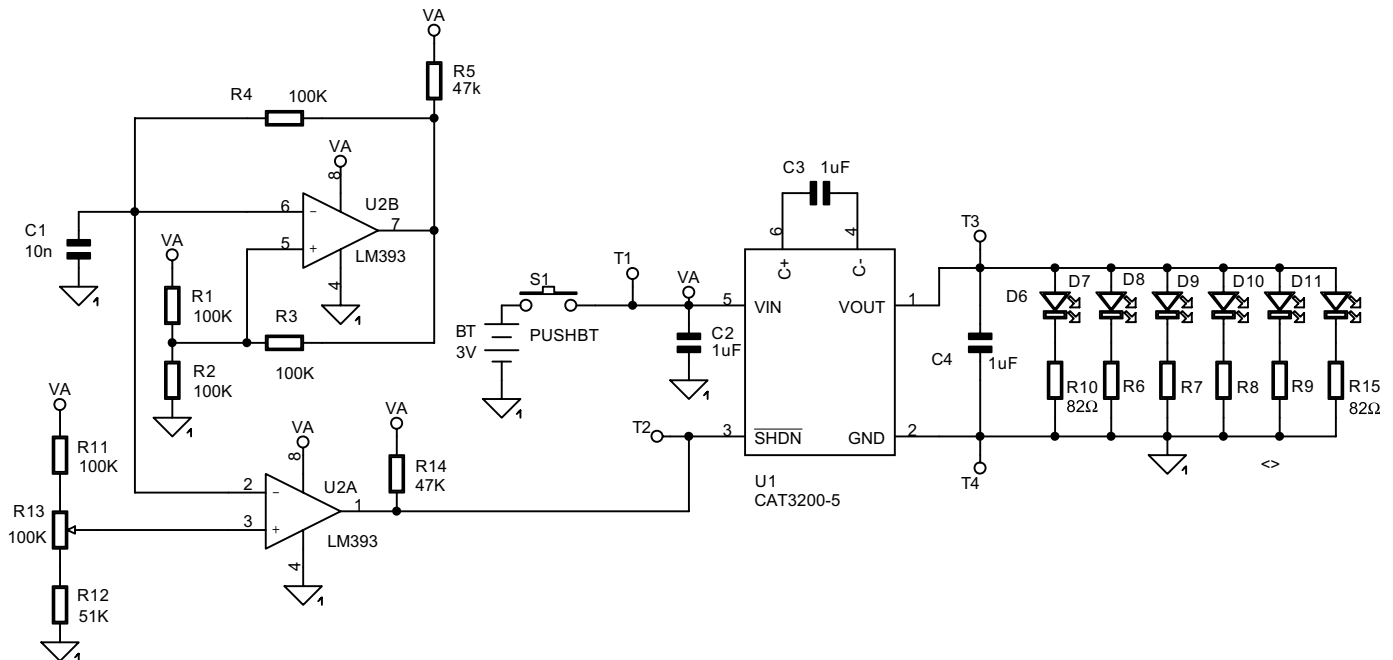

Figure 1. CAT3200DB1 Demo Board Schematic

A high switching frequency (2MHz) enables the use of small, external ceramic capacitors: one flying capacitor (C3) and two small bypass capacitors at VIN (C2) and VOUT (C4).

The six white LEDs are connected in parallel to the 5V regulated output voltage of the CAT3200-5 using series resistors. The LED current is set to a value of 15 mA to 20 mA to ensure a pure “white” light. The total current through the six LEDs should be less than or equal to the 100mA maximum output current of the CAT3200.

The board is powered through an attached battery pack (two 1.5V AA batteries). The power is applied through the S1 switch. To maximize the battery life, the input supply voltage is connected only when the momentary push-button switch, S1, is pushed.

LED Brightness Control

The board hardware provides a PWM signal connected to the shutdown input ($\overline{\text{SHDN}}$) of the CAT3200-5. The user can adjust the duty cycle of the signal applied to the SHDN pin using the linear slide potentiometer, R13, mounted on the left edge, back side of the board. The LEDs can be turned off or adjusted in brightness.

Table 1 presents the component list for this demo board. The component placement is shown in Figure 2.

CAT3200DB1 Demo Board List of Components

Name	Description	Manufacturer	Part Number	Units
U1	Regulated Charge Pump DC-DC Converter, SOT23 - 6pin (1mm Height)	Catalyst Semiconductor	CAT3200ES6-5	1
U2	Dual Comparator, +-18V, 300ns, SO8	Texas Instruments	LM393D-SMD	1
C1	Ceramic Capacitor 10 nF, SMT 1206	Kemet	CVNF010K12X	1
C2,C3,C4	Ceramic Capacitor 1 μ F, SMT 1206	Kemet	CVUF1K12Y	3
D6, D7, D8, D9, D10, D11	White LED SMT	Nichia	NSCW100	6
R1, R2, R3, R4, R11	100kohm Resistor, SMT 1206, 5%	VISHAY	CR1206K100	5
R5, R14	47kohm Resistor, SMT 1206, 5%	VISHAY	CR1206K047	2
R6, R7, R8, R9, R10, R15	82ohm Resistor, SMT 1206, 5%	VISHAY	CR1206E082	6
R12	51kohm Resistor, SMT 1206, 5%	VISHAY	CR1206K051	1
R13	100kohm Linear Potentiometer	CTS	448 UC2 104 BDN	1
S1	Momentary Contact Switch (on)-off	Diptronics	Digi-Key SW404-ND	1
T1, T2, T3, T4	Turret Pin	Mill-Max	2710-1-00-01-00-00-07-0	4
BTH	Battery Holder for 2 AA Cells, PC Mount	Keystone	Digi-Key 2462K-ND	1

Table 1. CAT3200DB1 Demo Board List of Components

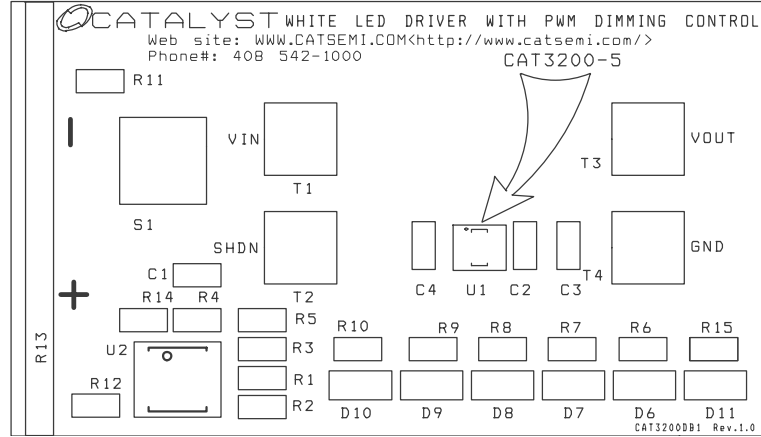

Figure 2. CAT3200DB1 Component Placement – Top Side



CATALYST

Catalyst Semiconductor, Inc.
Corporate Headquarters
1250 Borregas Avenue
Sunnyvale, CA 94089
Phone: 408.542.1000
Fax: 408.542.1200
www.catalyst-semiconductor.com

Publication #: 6030
Revision: A
Issue date: 8/20/03
Type: Final