



CAT3200DB2 Demonstration Board for the CAT3200 DC - DC Converter

Denisa Stefan, Applications Engineer
denisa.stefan@catsemi.com

1. INTRODUCTION

This document describes the CAT3200DB2 Demonstration Board for the CAT3200 charge pump DC-to-DC converter. This board shows a typical application of the CAT3200-5 driving multiple white LEDs in parallel. The CAT3200DB2 is the second version of the CAT3200-5 demo board.

The CAT3200 and CAT3200-5 are DC/DC boost converters that deliver a fully regulated output voltage. The 3200-5 has a fixed 5V output and the CAT3200 has an adjustable output. These devices provide a regulated output voltage from a 2.7 to 4.5V input voltage with output loads up to 100 mA.

A shutdown control input allows the device to be placed in low-power mode. In this mode of operation the load is disconnected from the input supply voltage and quiescent current is less than 1 μ A.

Detailed descriptions and electrical characteristics of the CAT3200/3200-5 are in the device data sheet.

2. CAT3200DB2 BOARD HARDWARE AND OPERATION

The demonstration board uses the CAT3200-5 to drive six white LEDs in parallel from a 3V battery. The board schematic is shown in Figure 1.

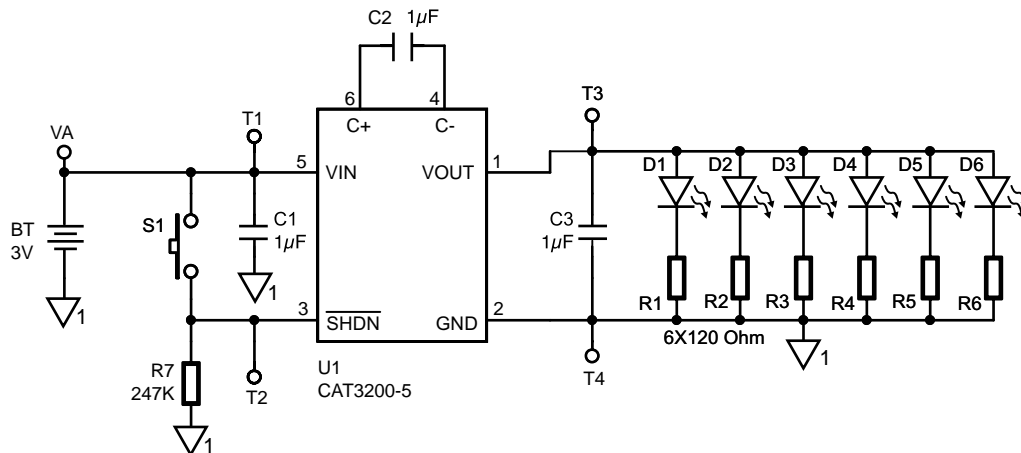

Figure 1. CAT3200DB2 Demo Board Schematic

A high switching frequency (2MHz) enables the use of small external ceramic capacitors: one flying capacitor (C2) and two small bypass capacitors at VIN (C1) and VOUT (C3).

The six white LEDs are connected in parallel to the 5V regulated output voltage of CAT3200-5 using series resistors. The LED current is set to a value of 15 mA approximately, to ensure a pure “white” light. The total current through all the six LEDs should be less than or equal to the 100mA maximum output current of the CAT3200.

The CAT3200-5 enters a low-power shutdown mode when SHDN input, which is controlled by S1 switch, is connected to ground. The LEDs will be turned on only when the momentary push button, S1, is pushed. The shutdown mode maximizes the battery life, since the CAT3200 shutdown quiescent current is typically 100 nA.

The board is powered through an attached battery pack (two 1.5V AA batteries). The input voltage, VIN, the SHDN input voltage and the output voltage, VOUT, can be measured at T1, T2, and T3 test points, respectively (T4 = GND).

Table 1 presents the component list for this demo board. The component placement is shown in Figure 2.

Name	Description	Manufacturer	Part Number	Units
U1	Regulated Charge Pump DC-DC Converter, SOT23 - 6pin (1mm Height)	Catalyst Semiconductor	CAT3200ES6-5	1
C1,C2,C3	Ceramic Capacitor 1 uF, SMT 1206	Kemet	CVUF1K12Y	3
D1 to D6	White LED SMT	Nichia	NSCW100	6
R1 to R6	120 ohm Resistor, SMT 1206, 5%	VISHAY	CR1206E100	6
R7	247Kohm Resistor, SMT 1206, 5%	VISHAY	CR1206K247	1
S1	Momentary Contact Switch (on)-off	Diptronics	Digi-Key SW404-ND	1
T1,T2,T3,T4	Turret Pin	Mill-Max	2710-1-00-01-00-00-07-0	4
BTH	Battery Holder for 2 AA Cells, PC Mount	Keystone	Digi-Key 2462K-ND	1

Table 1. CAT3200DB2 Demo Board List of Components

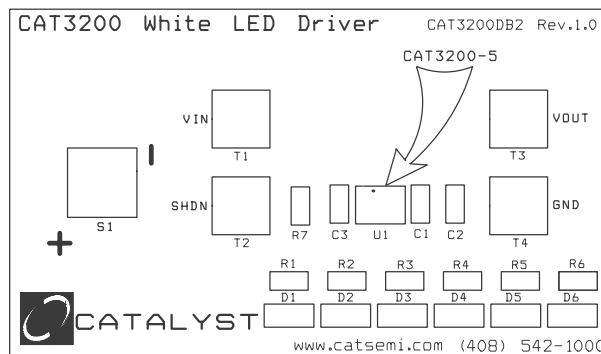

Figure 2. CAT3200DB2 Component Placement – Top Side



CATALYST

Catalyst Semiconductor, Inc.
Corporate Headquarters
1250 Borregas Avenue
Sunnyvale, CA 94089
Phone: 408.542.1000
Fax: 408.542.1200
www.catalyst-semiconductor.com

Publication #: 6038
Revision: A
Issue date: 7/27/04
Type: Final