

CAT3626DB1 Evaluation/Demo Board for CAT3626 6-Channel LED Driver

Denisa Stefan, Applications Engineer
Cornel Rotaru, Applications Engineer

1. INTRODUCTION

This document describes the CAT3626DB1 Evaluation/Demonstration Board for the Catalyst Semiconductor CAT3626 6-Channel LED driver with I²C interface. The functionality and major parameters of the CAT3626 can be evaluated with the CAT3626DB1 board.

The CAT3626 is a 6-channel charge pump that has been designed to drive up to 6 LEDs connected in parallel. The device can drive three groups of two LEDs. Each group can be configured with independent LED current of up to 32mA max per channel through the I²C serial interface. The CAT3626 is operating in either 1x mode (LDO), or 1.5x mode and provides tightly matched regulated current

through the six LED outputs. Each LED channel can be also turned off/on independently through the I²C bus. Detailed descriptions and electrical characteristics are in the CAT3626 data sheet.

2. CAT3626EVAL1 BOARD HARDWARE

The board contains the CAT3626 in a typical application circuit, driving 2 RGB LEDs or 6 white LEDs. The CAT3626 is controlled through the I²C serial interface using an 8-bit microcontroller. The user can chose to drive on/off any LEDs combination or to set the desired LED current through a PC serial interface. The board is powered from an attached 9V battery. The block diagram of the board hardware schematic is shown in Figure 1.

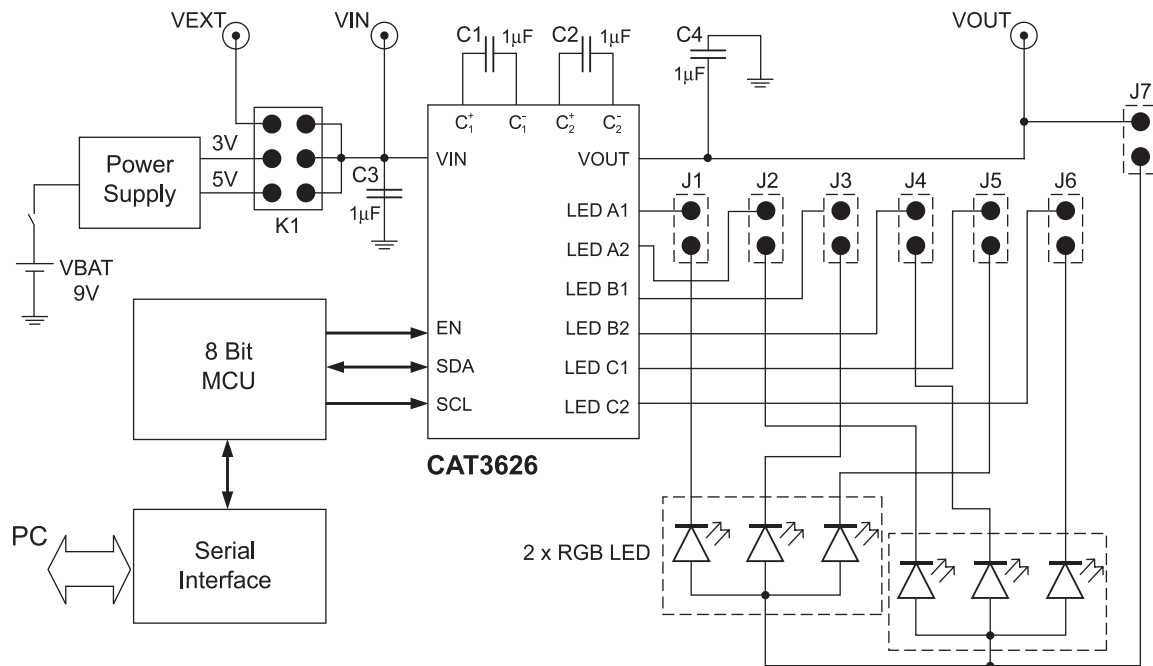

Figure 1. CAT3626DB1 Block Schematic

Application Note 30

The CAT3626 input voltage, VIN is supplied on board from a fixed +5V or +3V voltage (internally provided) or from an external voltage applied to the VEXT (T5) pad. The voltage supplied at the VIN input of the CAT3626 device can be selected using the jumper options for the K1 connector.

The board uses an 8-bit microcontroller, 8051 type. The microcontroller provides the signals on the SCL, SDA and EN lines to control the CAT3626.

The user can connect, or disconnect the CAT3626 outputs to the LEDs using the jumper options for J1, J2, J3, J4, J5, J6 and J7 connectors. J1 to J7 header pin connectors can be used to insert a current meter to evaluate the programmed LED current on each channel.

The board is powered when the “POWER” switch is ON. The CAT3626DB1 boards are populated with two RGB LEDs (Everlight EL61-23RGBC).

The component placement, top side, for the CAT3626DB1 and the board picture are shown in Figure 2.

The detailed schematic and the list of components for the CAT3626DB1 are shown in the Appendix attached in the end of this document.

3. BOARD OPERATION

3.1. Stand-alone Board

The board can be also used as a demonstration board without connection to the PC interface. As a stand-alone board, when the POWER switch is turned ON, the microcontroller starts executing a routine that sequentially sets different LED current values for each

of 3 groups LED output channels. As a result the 2 RGB LEDs will provide the colors mixing between RED, GREEN and BLUE with different intensities. This loop is executed as long as the board is powered.

Note: To use as a stand-alone board, the J9 connector must have the jumper removed; otherwise, the microcontroller does not start the routine of controlling the CAT3626 at power-on.

3.2. CAT3626DB1 Board Controlled through the PC Serial Interface

The user can set the desired LED current value for each of CAT3626 output channel connecting the CAT3626DB1 through a PC serial interface. The CAT3626DB1 software provides the user a very friendly graphical interface (GUI) for sending all the commands to drive on/off any LEDs configuration and to program the LEDs current.

The CAT3626DB1 software requires the following minimum system configuration:

- Microsoft Windows 98SE or above
- 100K of available hard disc space
- Serial Interface Port

The software is available on the CAT3626DB1 software distribution CD-ROM or can be downloaded at:

www.catsemi.com/evaluationtools.

The CAT3626DB1 software is an executable program (“CAT3626DB.exe”) which can be run from any directory or CD.

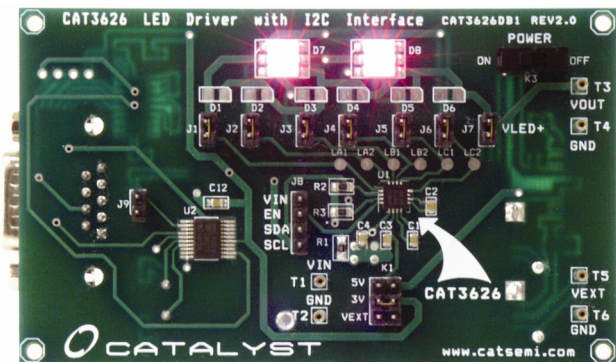
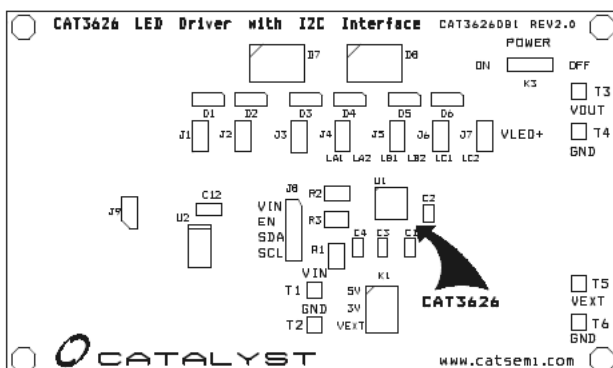

Figure 2. CAT3626DB1 Component Placement – Top Side

The following steps should be followed to control the CAT3626DB1 demo board from the PC:

- a) Connect the CAT3626DB1 board to the PC serial port through a cable with 9-pin connectors, extender type. (For a limited quantity the connection cable is provided.)
- b) Connect a jumper shunt at J9 connector. This allows the CAT3626 to remain disabled (EN = "0") at power-on.
- c) Power the CAT3626DB1 board: Turn the "POWER" switch ON. (The board should be powered when you start the program; otherwise an error message will be displayed).
- d) Run the "CAT3626DB.exe" program from the directory where the software was installed.
- e) The CAT3626 Demo Board user interface window opens (Figure 3).
- f) When the program starts, the board will be in the disabled state. Press the "ENABLE" button and the CAT3626 will be enabled. After setting the EN input high, the user can write into the Register_S to activate the corresponding LED output channels. Figure 4 shows all the LED channels active. The current for each channel is set at the minimum value (=0.5mA).
- g) Using the CAT3626DB1 software the user can access all the internal registers of the CAT3626:
 - Register A: set the LED current for group A (LEDA1, LEDA2) – associated with Red from RGB LEDs
 - Register B: set the LED current for group B (LEDB1, LEDB2) – associated with Green from RGB LEDs
 - Register C: set the LED current for group C (LEDC1, LEDC2) – associated with Blue from RGB LEDs
 - Register S: controls the ON/OFF state of each LED channel independently.

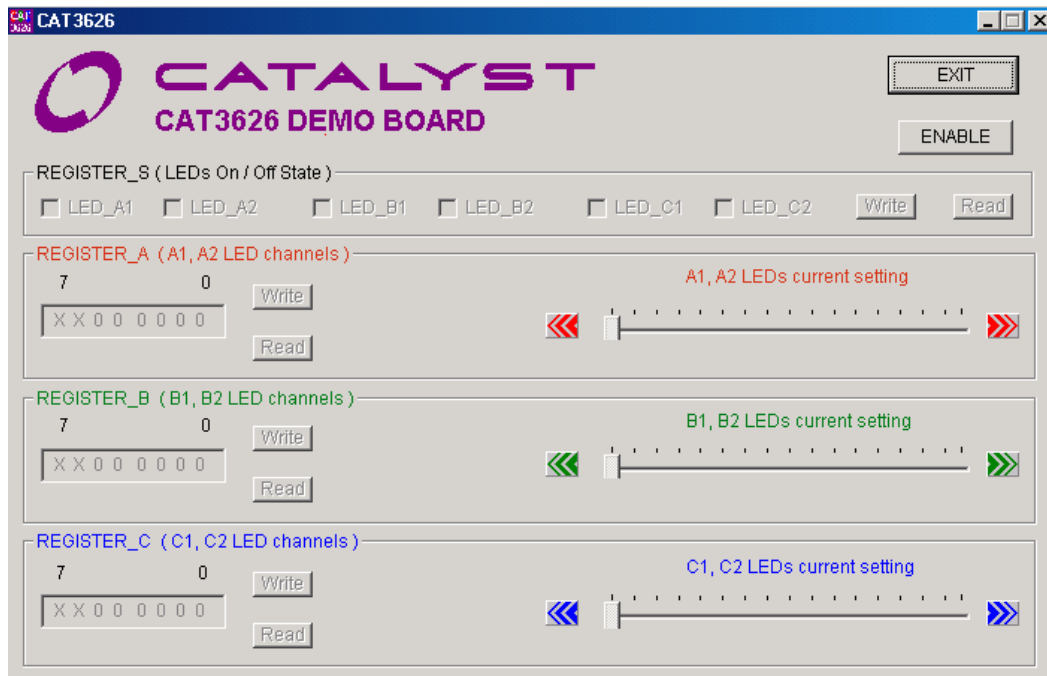

Figure 3. CAT3626DB1 Software Interface Window (start window)

The user can set the current for any group, writing the associated register with the desired value. The current can be set between 0.5mA and 32mA. These 64 steps corresponds to the binary registers values of XX000000 to XX111111. The user can change the LED current value writing the corresponding binary value in the associated Register (A, B or C). Every register has associated “Write” and “Read” buttons to write and respectively read data. The current value

can be also changed moving the cursor or/and pressing the arrows buttons on the slider associated to each register.

As an example, Figure 5 shows all the channels enabled and the LED currents set to 15mA (Group A – Red), 30mA (Group B – Green) and 3mA (Group C – Blue).

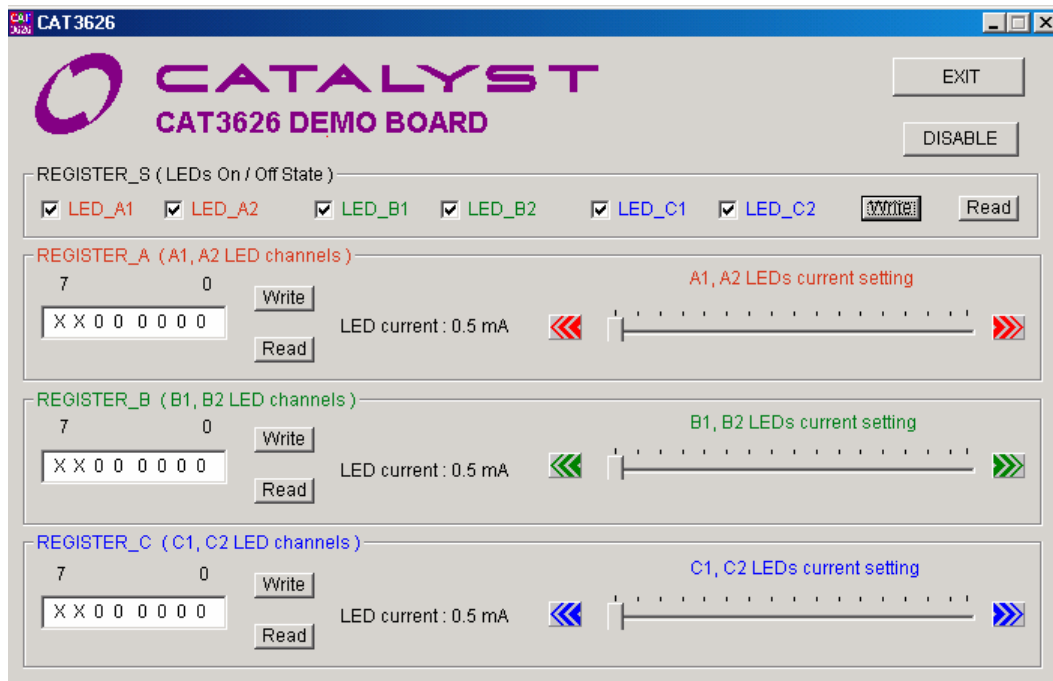

Figure 4. CAT3626DB1 with all channels enabled and LED currents set to min value

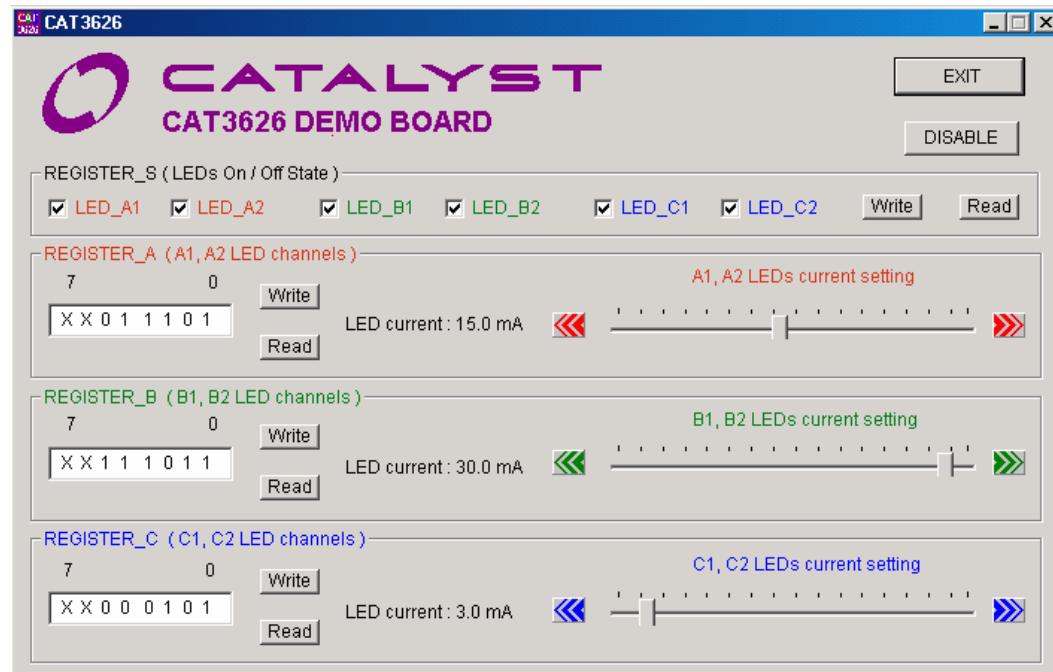

Figure 5. CAT3626DB1 Board sets LED current independently for each LED group

4. APPENDIX

The detailed board schematics and the list of components are shown in Figure 6 and Table 1.

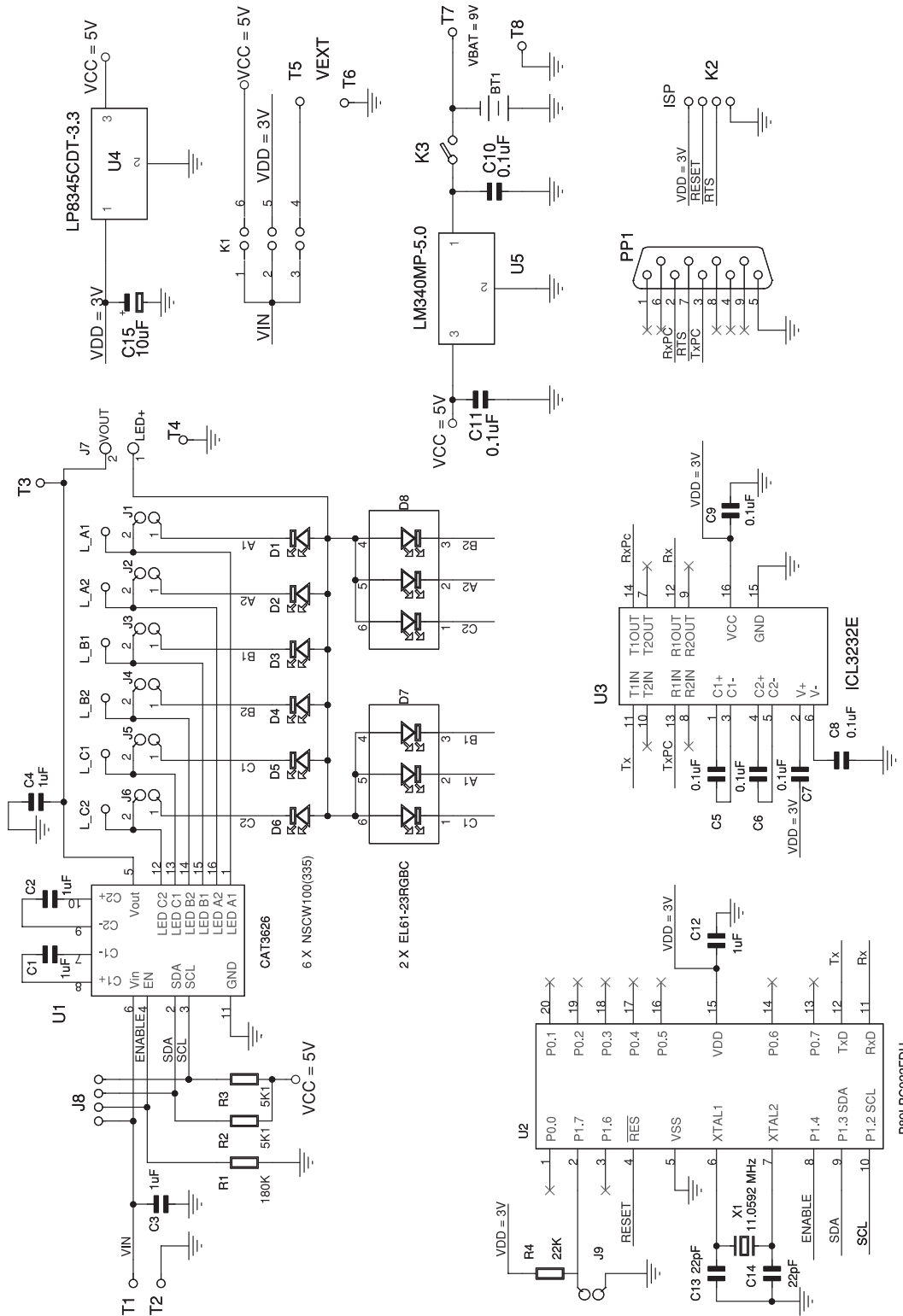

Figure 6. CAT3626DB1 Board Schematic

Table 1. CAT3626DB1 Board List of Components

Name	Manufacturer	Description	Part Number	Units
U1	Catalyst Semiconductor	6-Channel LED Driver with I2C interface, QFN16	CAT3626HS4	1
U2	Philips Semiconductor	8-bit flash microcontroller TSSOP20	P89LPC922FDH	1
U3	Intersil	RS-232 Transmitter/receiver, SOIC16 Narrow	ICL3232ECBN	1
U4	National Semiconductor	3V, 500mA Voltage Regulator, DPAK	LP8345CDT-3.3	1
U5	National Semiconductor	5V Voltage Regulator, 1A, SOT223	LM340MP-5.0	1
C1, C2, C3, C4, C12	AVX	Ceramic Capacitor 1uF / 10V, 10%, X5R, Size 0603	0603ZD105KAT2A	4
C5, C6, C7, C8, C9, C10, C11	AVX	Ceramic Capacitor 0.1uF / 10V, 10%, X7R, Size 0805	0805ZC104KAT2A	7
C13, C14	AVX	Ceramic Capacitor 22pF / 100V, 5% COG, Size 1206	12061A220JAT2A	2
C15	AVX	Tantalum 10uF / 10V, 10%, Low ESR	TPSA106K010R1800	1
R1	Dale	SMT Resistor 1/8W, 180Kohm, 1%, Size 0805	CRCW0805180KFKTA	1
R2, R3	Dale	SMT Resistor 1/8W, 5K1, 1%, Size 0805	CRCW08055K10FKTA	2
R4	Dale	SMT Resistor 1/8W, 22Kohm, 1%, Size 0805	CRCW080522KFKTA	1
D1 to D6	Nichia	White LED – Not Soldered	NSCW100	6
D7, D8	Everlight	RGB LED, SMD	EL61-23RGBC	2
J1 to J7. J9	MMM	2-pin Header Connector, 0.1", Single Strip	2302-6211TG	8
J8	MMM	4-pin Header Connector, 0.1", Single Strip	23046211TG	1
K1	MMM	6-pin Header Connector, 0.1", Double Strip	2308-62221TG	1
K3	ITT Cannon	Slide switch	L102-01-1-MS-02-Q2	1
X1	Vishay	Crystal 11.0592 MHz	XT9SNLANA11M0592	1
	Specialty Electronics	Jumper Shunts	2JM-G	9
PP1	ITT Cannon	D-Sub-Plug 9-Pole Solder Pin	DE-9P	1
T1 to T6	Mil-Max	Pin Receptacle	#0149-0-15-01-30-14-04-0	6
BTH	Keystone	Battery Holder 1x 9V	BHR1294	1

REVISION HISTORY

Date	Rev.	Reason
03/17/2006	A	Initial Issue

Copyrights, Trademarks and Patents

Trademarks and registered trademarks of Catalyst Semiconductor include each of the following:

DPP TM AE2 TM

Catalyst Semiconductor has been issued U.S. and foreign patents and has patent applications pending that protect its products.

CATALYST SEMICONDUCTOR MAKES NO WARRANTY, REPRESENTATION OR GUARANTEE, EXPRESS OR IMPLIED, REGARDING THE SUITABILITY OF ITS PRODUCTS FOR ANY PARTICULAR PURPOSE, NOR THAT THE USE OF ITS PRODUCTS WILL NOT INFRINGE ITS INTELLECTUAL PROPERTY RIGHTS OR THE RIGHTS OF THIRD PARTIES WITH RESPECT TO ANY PARTICULAR USE OR APPLICATION AND SPECIFICALLY DISCLAIMS ANY AND ALL LIABILITY ARISING OUT OF ANY SUCH USE OR APPLICATION, INCLUDING BUT NOT LIMITED TO, CONSEQUENTIAL OR INCIDENTAL DAMAGES.

Catalyst Semiconductor products are not designed, intended, or authorized for use as components in systems intended for surgical implant into the body, or other applications intended to support or sustain life, or for any other application in which the failure of the Catalyst Semiconductor product could create a situation where personal injury or death may occur.

Catalyst Semiconductor reserves the right to make changes to or discontinue any product or service described herein without notice. Products with data sheets labeled "Advance Information" or "Preliminary" and other products described herein may not be in production or offered for sale.

Catalyst Semiconductor advises customers to obtain the current version of the relevant product information before placing orders. Circuit diagrams illustrate typical semiconductor applications and may not be complete.



Catalyst Semiconductor, Inc.
Corporate Headquarters
1250 Borregas Avenue
Sunnyvale, CA 94089
Phone: 408.542.1000
Fax: 408.542.1200
www.catsemi.com

Document No: 6047
Revision: A
Issue date: 03/17/06