

CAT4238EVAL1 Evaluation Board for CAT4238 10-LED Boost Converter

Denisa Stefan, Applications Engineer
denisa.stefan@catsemi.com

1. INTRODUCTION

This document describes the CAT4238EVAL1 Evaluation Board for the Catalyst Semiconductor CAT4238 High Efficiency 10-LED Boost Converter. The functionality and major parameters of the CAT4238 can be evaluated with the CAT4238EVAL1 board.

The CAT4238 is a high voltage CMOS constant-current DC/DC converter that has been designed to drive with high efficiency white or other high brightness LEDs. The high-voltage output stage allows driving up to 10 white LEDs in series. A single external resistor sets the LED current between 5mA and 40 mA. LED current can be adjusted using either a pulse width modulated (PWM) signal or a DC voltage. Detailed descriptions and electrical characteristics are in the CAT4238 data sheet.

2. CAT4238EVAL1 BOARD HARDWARE

The evaluation board contains a CAT4238 DC-DC boost converter in a typical application circuit. As configured, the board circuit is set to drive up to 10 white LEDs in series. The user can chose to connect the CAT4238 output to the on-board LEDs string or to an external LEDs string from an application.

The board provides the option to connect a different number of LEDs available on board, 8, 9 or 10, using a jumper shunt for one of the J2 to J4 connectors. The board schematic is shown in Figure 1.

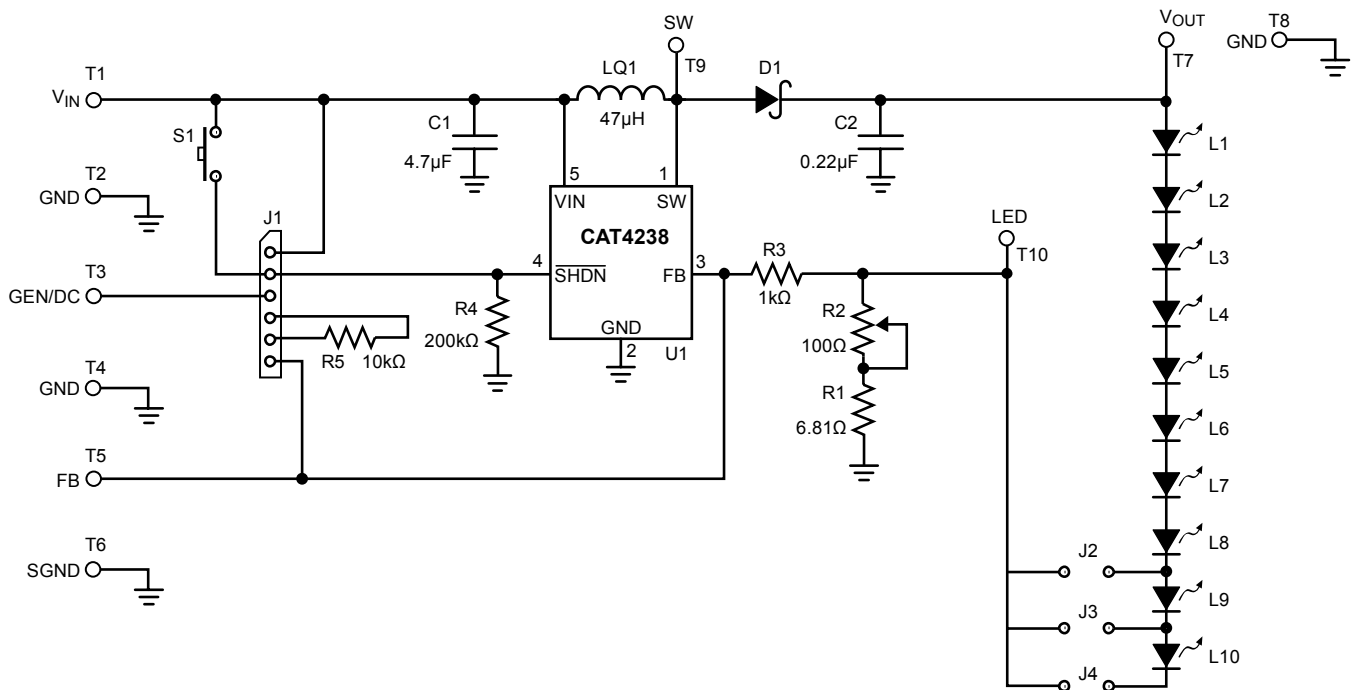

Figure 1. CAT4238EVAL1 Board Schematic

Application Note 32

The board is powered from an external voltage applied to the V_{IN} (T1) pad. The circuit is delivered with no LEDs soldered on board. The user can solder his white LEDs on the CAT4138 board (8 to 10 LED string pads layout provided) or he can choose to connect the LEDs from his application between V_{OUT} (T7) and LED (T10) test points.

The LED current is set through the external resistors connected to the FB pin (R1, R2). Using the variable resistor R2, the LED current can be set from 3mA to 40mA. Most white LEDs are driven at a maximum current between 15mA and 20mA to ensure a pure “white” light.

The board also demonstrates the CAT4238 shutdown mode and LED brightness control by using an external

PWM signal or a DC voltage. Resistors R3 and R5 (R5 – soldered on board by the user) are used to adjust the LED current using the dimming control with an external applied DC voltage on the FB pin. The ON/OFF operation and dimming control can be selected using the jumper options for the J1 connector.

Test points T1 to T10 are available to apply the external voltages/signal generator or to measure the output voltages / signals provided by CAT4238.

The component placement is shown in Figure 2. Table 1 presents the component list for this evaluation board.

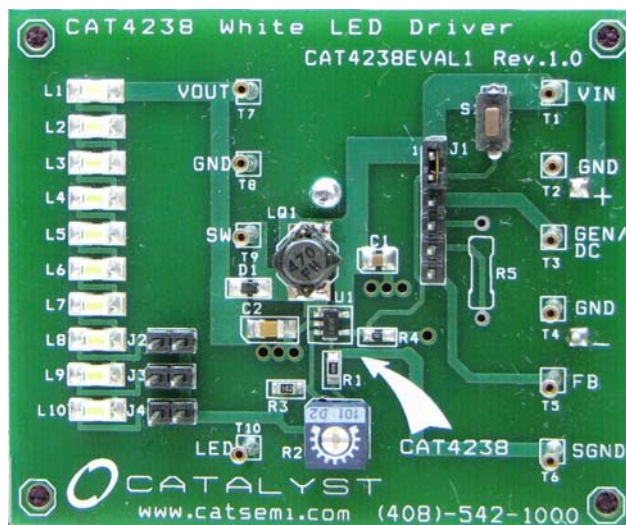
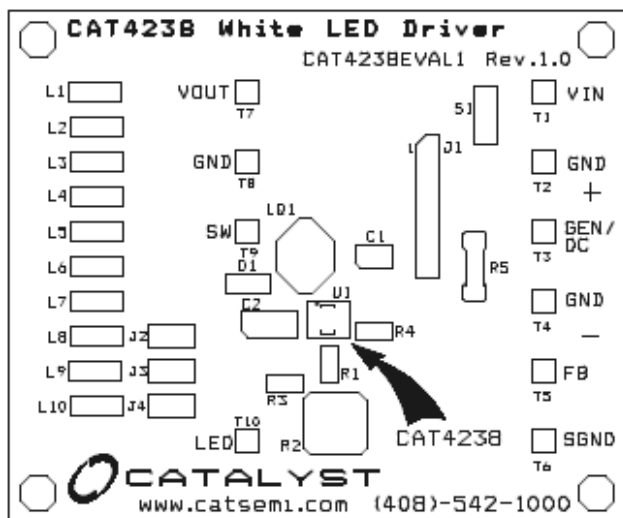

Figure 2. CAT4238EVAL1 Board

Table 1. CAT4238EVAL1 Board List of Components

Name	Manufacturer	Description	Part Number	Units
U1	Catalyst	CMOS White LED Driver, TSOT23 - 5pin	CAT4238TD-G	1
C1	Taiyo Yuden (or Panasonic)	Ceramic Capacitor 4.7 μ F/ 6.3V, X5R, Size 0805	JMK212BJ475 (or Digi-Key PCC2315CT-ND)	1
C2	Taiyo Yuden (or Kemet)	Ceramic Capacitor 0.22 μ F / 50V, X5R(X7R)	UMK212BJ224KG (Digi-Key 587-1287-1-ND)	1
L1	Sumida	Inductor 47 μ H, low DCR, high current	CDC5D23B-470 (or CDR6D23MN-470)	1
D1	Central Semi	Schottky Diode, Low VF, 40V, 500mA, SOD-323	CMDSH05-4	1
R1	Yageo	SMT Resistor 1/16W, 6.81 Ω , 0603	Digi-Key 311-6.81HCT-ND	1
R2	Bourns	Trimmer Pot, 1/4", 100 Ω	3329W-101-ND (or equiv)	1
R3	Yageo	SMT Resistor 1/16W, 1.0k Ω , 0603	Digi-Key 311-1.0KHCT-ND	1
R4	Yageo	SMT Resistor 1/16W, 200k Ω , 0603	Digi-Key 311-200KHCT-ND	1
R5	Yageo	Metal Film Resistor 1/16W, 10k Ω (not soldered on board)	Digi-Key 10.0KXBK-ND	
L1 to L10	Nichia	White LED, SMT (optional)	NSCW100 or NSCW335	10
J1		6-pin Header Connector, 0.1", Single Strip	Digi_Key S1012-06-ND (or equiv)	1
J2 to J4		2-pin Header Connector, 0.1", Single Strip (optional)	Digi_Key S1012-02-ND (or equiv)	3
T1 to T10	Mil-Max	Pin Receptacle (Test Points)	#0149-0-15-01-30-14-04-0 (or equiv)	10

3. CAT4238 EVALUATION

The CAT4238EVAL1 gives the user a way to evaluate the CAT4238 in a typical application of driving multiple LEDs.

The following steps are an example of how the user can evaluate the CAT4238 white LED driver:

1) Driving 10 LEDs in series and Shutdown Mode

- a) Connect the 10-LED string to the CAT4238 output through J4 header pin connector.
- b) Set the R2 potentiometer to the middle position.
- c) Apply the external voltage supply, V_{ext} ($3.0V < V_{IN} < 5V$) between V_{IN} (T1) and GND (T2).
- d) The CAT4238 is in the **shutdown mode** (SHDN pin is connected to GND) if the J1 connector (Pin #1 – Pin #2) is not jumpered.
 - Connect a current meter between V_{ext} and V_{IN} pad to measure the shutdown current: $I_{SD} \ll 1\mu A$.
 - In this mode of operation the LEDs are disconnected from the output: LEDs are OFF.
- e) Connect SHDN pin of CAT4238 to V_{IN} using a jumper shunt between Pin #1 and Pin #2 of J1 connector
 - Observe that LEDs are ON.

Application Note 32

2) LED Current Evaluation

a) Programming LED current

LED current is programmed using the external resistors, $R_{SET} = R1 + R2$, connected to the FB pin. The voltage at the FB pin is internally regulated to the value $V_{FB} = 300\text{mV} \pm 15\text{mV}$.

The current into the LED pin can be set according to the following equation:

$$I_{LED}(\text{mA}) = \frac{V_{FB}(\text{mV})}{R_{SET}(\Omega)} = \frac{v_{FB}}{R1+R2}$$

- Set the input voltage: ex. $V_{IN} = 3.6\text{V}$.
- Disconnect the jumper from the J4, connector and insert a current meter between these pins to monitor the LED current, I_{LED} .
- Rotate the potentiometer R2 and observe the I_{LED} value on the current meter. The current can be adjusted between 3mA and 30mA, approximately. Various LED current values and the associated RSET values are listed below:

I_{LED} (mA)	R_{SET} (Ω)
5	59
10	29.8
15	20
20	15
25	12
30	10

- Monitor the voltage on FB (T5), V_{OUT} (T7), and SW (T9).
- Verify the internal switch frequency ($f_{SW} = 1.0\text{MHz}$ typically) using a scope probe connected on SW (T9) test point (GND = T8).

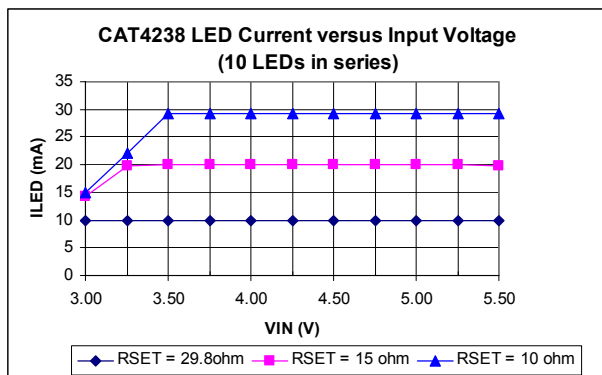

Note: $R_{SET} = R1 + R2$

Figure 4. LED current Line Regulation

Figure 3 shows the internal switch output, V_{SW} (DC coupled, 5V/div) and the regulated voltage on FB pin, V_{FB} (DC, 500mV/div) for $V_{IN} = 3.6\text{V}$, $I_{LED} = 20\text{mA}$, 10 LEDs in series connected to the CAT4238 output.

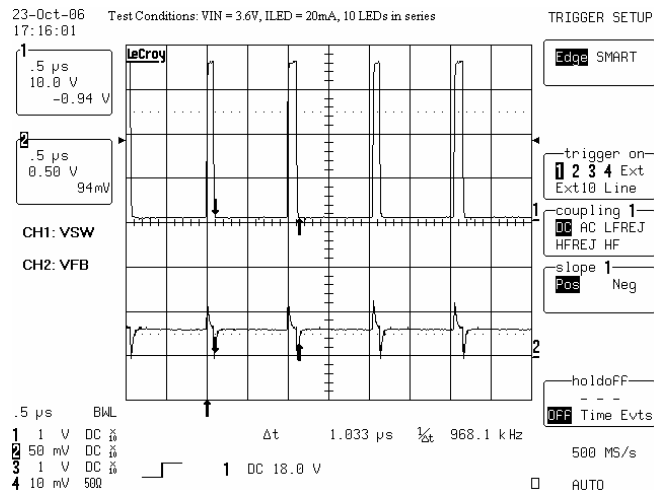

Figure 3. Internal Switch Output and Regulated V_{FB} Voltage Waveforms ($I_{LED} = 20\text{mA}$, $V_{IN} = 3.6\text{V}$)

b) Evaluating LED current regulation versus the input voltage, V_{IN} .

- Set the I_{LED} to a programmed value using the R2 potentiometer (i.e. 10mA, 20mA, 30mA for $V_{IN} = 3.6\text{V}$)
- For any I_{LED} value vary the V_{IN} voltage between 3.0V and 5.5V
- Observe the value of I_{LED} measured by the current meter and V_{FB} using a voltmeter. Figure 5 presents the I_{LED} current versus V_{IN} . Figure 5 shows the CAT4238 FB voltage versus input voltage.

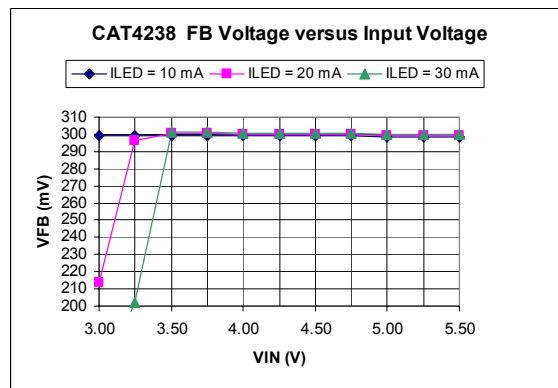

Figure 5. V_{FB} voltage Line Regulation

3) Efficiency Evaluation

The efficiency is evaluated according to the following equation:

$$\text{Efficiency (\%)} = \frac{I_{LED} \times \sum VFi}{I_{IN} \times V_{IN}} \times 100$$

where $\sum VFi = V_{OUT} - V_{LED}$, V_{LED} is the voltage measured on LED (T10) test point.

- Insert a current meter, CM1, between input supply voltage, V_{ext} , and V_{IN} pad to monitor the input current, I_{IN} (or use an embedded power supply current meter).
- Set the input voltage for $V_{IN} = 3.6V$
- Adjust the R2 potentiometer for the $I_{LED} = 5mA$. Observe the I_{LED} current on the meter, CM2, inserted between Pin #1 and Pin #2 of J4 connector.
- Measure the I_{IN} current on CM1
- Monitor the output voltage on V_{OUT} (T7) and V_{LED} voltage on LED (T10) test points.
- Repeat steps c) to e) for $I_{LED} = 10mA, 15mA, 20mA, 25mA$ and $30 mA$.

Figure 6 shows the efficiency measured for 2 values of input voltage, $V_{IN} = 3.6V$ and $V_{IN} = 4.2V$, with 10 LEDs in series connected to the CAT4238 output.

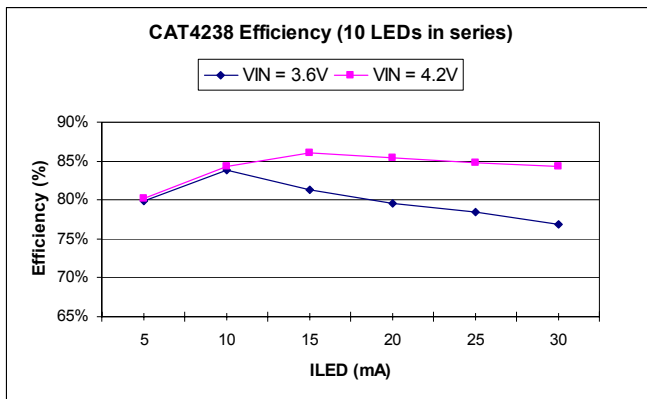

Figure 6. CAT4238 Efficiency driving 10 LEDs in series

4) Dimming Control

The LED brightness control can be accomplished by using a PWM signal applied to the SHDN pin or to the FB pin. The other method is to use a variable DC voltage applied through a resistor to FB pin.

a) Dimming using a PWM signal on the SHDN pin.

The LEDs are turned off and on at the PWM frequency. The average current changes with the duty cycle. Increasing the duty cycle will increase the LED brightness. The peak current value sets the light spectrum.

- Connect the jumper shunt between Pin #2 and Pin #3 of the J1 connector.
- Apply a pulse signal generator to the GEN/DC (T3) pad; Frequency = 200Hz to 2kHz; Amplitude 0V to 3V for. $V_{IN} = 3.6V$.
- Modify the duty cycle between 0% and 100%.
- Observe the average current through LEDs measured by a current meter inserted at J4 connector. For 0% duty cycle, the I_{LED} will be off ($I_{LED} = 0mA$); At the maximum duty cycle, the LED will be driven at the maximum current set by the R2 potentiometer.
- Monitor the FB voltage compared with the PWM signal applied on SHDN input.

Figure 7 shows the voltage monitored on the FB pin, V_{FB} (CH2) using a PWM signal applied to the SHDN pin (CH1). The frequency of the PWM signal is 2kHz approximately.

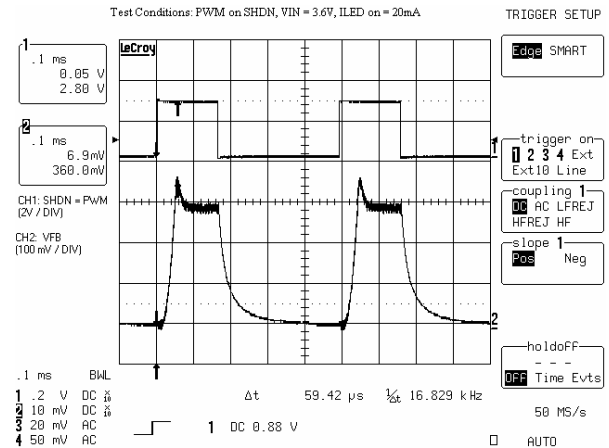

Figure 7. FB Voltage Waveform with PWM

b) Dimming using a DC voltage applied to the FB pin

A variable external DC voltage is applied on FB pin to adjust the LED current. As the DC voltage is increased, the voltage drop on resistor R3 is increased and the voltage drop on RSET = R1+R2 is decreased, thus the LED current decreases. The external DC voltage is applied to FB pin through a series resistor, R5, which sets the maximum DC voltage.

Also, a filtered PWM signal can be considered as a variable DC voltage.

- Connect the SHDN pin to V_{IN} : jumper shunt between Pin #1 and Pin #2 of J1 connector.
- Set the I_{LED} current (i.e. $I_{LED\ MAX} = 20\text{mA}$)
- Connect the GEN/DC to FB pin through R5 resistor using one jumper between Pin #3 and Pin #4 and another jumper shunt between Pin #5 and Pin #6 of J1 connector.
- Apply the variable DC voltage between GEN/DC (T3) and GND (T4).
- Increase the DC voltage value (from 0V to $V_{MAX} = 3.2\text{V}$).
- Observe the I_{LED} current decreases from the $I_{LED\ MAX}$ (20mA – previous set) to $I_{LED\ MIN}$ (0mA for $V_{MAX} = 3.2\text{V}$ with the existing resistors values, $R3 = 1\text{k}\Omega$, $R5 = 10\ \text{k}\Omega$).

REVISION HISTORY

Date	Rev.	Reason
11/09/2006	A	Initial Issue

Copyrights, Trademarks and Patents

Trademarks and registered trademarks of Catalyst Semiconductor include each of the following:

Beyond Memory™, DPP™, EZDim™, MiniPot™, and Quad-Mode™

Catalyst Semiconductor has been issued U.S. and foreign patents and has patent applications pending that protect its products.

CATALYST SEMICONDUCTOR MAKES NO WARRANTY, REPRESENTATION OR GUARANTEE, EXPRESS OR IMPLIED, REGARDING THE SUITABILITY OF ITS PRODUCTS FOR ANY PARTICULAR PURPOSE, NOR THAT THE USE OF ITS PRODUCTS WILL NOT INFRINGE ITS INTELLECTUAL PROPERTY RIGHTS OR THE RIGHTS OF THIRD PARTIES WITH RESPECT TO ANY PARTICULAR USE OR APPLICATION AND SPECIFICALLY DISCLAIMS ANY AND ALL LIABILITY ARISING OUT OF ANY SUCH USE OR APPLICATION, INCLUDING BUT NOT LIMITED TO, CONSEQUENTIAL OR INCIDENTAL DAMAGES.

Catalyst Semiconductor products are not designed, intended, or authorized for use as components in systems intended for surgical implant into the body, or other applications intended to support or sustain life, or for any other application in which the failure of the Catalyst Semiconductor product could create a situation where personal injury or death may occur.

Catalyst Semiconductor reserves the right to make changes to or discontinue any product or service described herein without notice. Products with data sheets labeled "Advance Information" or "Preliminary" and other products described herein may not be in production or offered for sale.

Catalyst Semiconductor advises customers to obtain the current version of the relevant product information before placing orders. Circuit diagrams illustrate typical semiconductor applications and may not be complete.



Catalyst Semiconductor, Inc.
Corporate Headquarters
2975 Stender Way
Santa Clara, CA 95054
Phone: 408.542.1000
Fax: 408.542.1200
www.catsemi.com

Document No: 6050
Revision: A
Issue date: 11/09/06