

# EdiLine II Series

The linear structure of EdiLine II Series results in an easier heat dissipation requirement, making versatile fixtures design possible as well as an overall cost saving benefit. The special twin connectors design allows EdiLine II Series to be assembled easily with screws in either serial order as a linear light source or parallel order as a planar light source. Furthermore, the high CRI options allow the customers to optimize the effect in various fields such as interior architecture.

## Features

- Linear Packaging Design
- High Efficiency
- Low Power Consumption
- Long Operating Lifespan
- Easy Installation with Screws
- High CRI : 90

---

## Table of Contents

Product Nomenclature .....	2
Environmental Compliance .....	3
LED Package Dimensions and Polarity .....	4
Absolute Maximum Ratings .....	5
Luminous Flux Characteristics .....	6
Forward Voltage Characteristics .....	7
Reliability Items and Failure Measures .....	8
Color Spectrum and Radiation Pattern.....	9
Optical & Electrical Characteristics .....	13
Product Thermal Application Information .....	16
Product Electrical Application Information.....	19
Product Packaging Information .....	20

## Product Nomenclature

The following table describes the available color, power, and lens type. For more information on luminous flux and color distribution, please refer to the Bin Group document.

< Table 1 EdiLine II series nomenclature >

X1		X2		X3		X4		X5		X6		X7		X8		X9	
LED Item		Item		Emitting Color		Power		Material		Circuit Type		Connector Type		Phosphor Item		Serial No.	
Code	Type	Code	Type	Code	Type	Code	Type	Code	Type	Code	Type	Code	Type	Code	Type	Code	Type
EL	EdiLine	E	Type I	W	Cool White	○	5	5W			A	3 Parallel with 5 Serial					
		A	Type II	H	Neutral White	●					B	3 Parallel with 10 Serial					
		H	Heatsink	X	Warm White	●											
				R	Red	●											
				T	True Green	●											
				B	Blue	●											

### Environmental Compliance

EdiLine II series are compliant to the Restriction of Hazardous Substances Directive or RoHS. The restricted materials including lead, mercury cadmium hexavalent chromium, polybrominated biphenyls (PBB) and polybrominated diphenyl ether (PBDE) are not used in EdiLine II series to provide an environmentally friendly product to the customers.

## LED Package Dimensions and Polarity

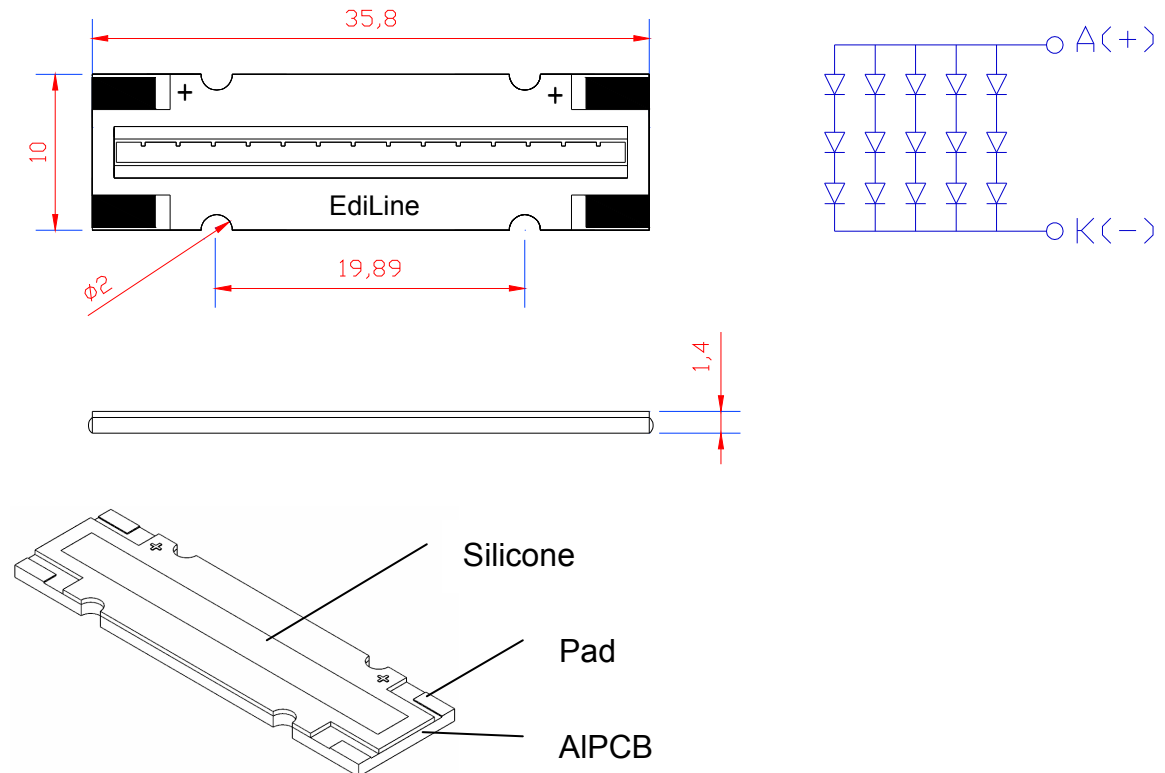

< Figure 1 Ediline II series dimensions >

### Notes:

1. All dimensions are measured in mm.
2. Tolerance : 0.2 mm
3. It is strongly recommended that the temperature of ALPCB dose not exceed 55°C

## Absolute Maximum Ratings

< Table 2 Absolute maximum ratings for EdiLine II series >

Parameter	W / H / X / B / T	Red	Unit	Symbol
DC Forward Current	500	600	mA	$I_F$
Peak pulse current;(tp $\leq$ 100 $\mu$ s, Duty cycle=0.25)	1,000	1,000	mA	
Reverse Voltage	5	5	V	$V_R$
Forward Voltage	12	9	V	$V_F$
Arc Voltage	20	20	V	
LED junction Temperature	125	125	$^{\circ}$ C	$T_j$
Operating Temperature	-30 ~ +110	-30 ~ +110	$^{\circ}$ C	
Storage Temperature	-40 ~ +120	-40 ~ +120	$^{\circ}$ C	
Soldering Temperature	260	260	$^{\circ}$ C	
ESD Sensitivity	500	500	V	
Manual Soldering Time at 260 $^{\circ}$ C (Max.)	5	5	Sec.	

### Notes:

1. W / H / X / R / B / T are denoted as Cool White, Neutral White, Warm White, Red, Blue, and True Green, respectively.
2. Proper current rating must be observed to maintain junction temperature below the maximum at all time.
3. LEDs are not designed to be driven in reverse bias.

The following table describes thermal resistance of EdiLine II series under various current and different colors.

< Table 3 Temperature coefficient of  $V_F$  &  $R_{TH}$  (j-c) at  $T_j=25^{\circ}$ C for EdiLine II series >

Part Name	Color	Test Current	$\Delta V_F / \Delta T$		$R_{\theta J-B}$	
			Typ.	Units	Typ.	Unit
ELAW-5AA0-B00	Cool White	500mA	-6	mV/ $^{\circ}$ C	6	$^{\circ}$ C/W
ELAW-5AA0-D00	Cool White	500mA	-6	mV/ $^{\circ}$ C	6	$^{\circ}$ C/W
ELAH-5AA0-E00	Neutral White	500mA	-6	mV/ $^{\circ}$ C	6	$^{\circ}$ C/W
ELAH-5AA0-D00	Neutral White	500mA	-6	mV/ $^{\circ}$ C	6	$^{\circ}$ C/W
ELAX-5AA0-E00	Warm White	500mA	-6	mV/ $^{\circ}$ C	6	$^{\circ}$ C/W
ELAX-5AA0-D00	Warm White	500mA	-6	mV/ $^{\circ}$ C	6	$^{\circ}$ C/W
ELAR-5DA0-A00	Red	600mA	-6	mV/ $^{\circ}$ C	6	$^{\circ}$ C/W
ELAT-5AA0-A00	True Green	500mA	-6	mV/ $^{\circ}$ C	6	$^{\circ}$ C/W
ELAB-5AA0-A00	Blue	500mA	-6	mV/ $^{\circ}$ C	6	$^{\circ}$ C/W

## Luminous Flux Characteristics

The following table describes flux of EdiLine II series under various current and different colors.

< Table 4 Luminous flux characteristics at  $T_j=25^{\circ}\text{C}$ : for EdiLine II series >

Part Name	Color	Test Current	Flux			Unit	
			Min.	Typ.	Max.		
ELAW-5AA0-B00	Cool White	500mA	170	250	--	lm	
ELAH-5AA0-E00	Neutral White	500mA	130	180	--	lm	
ELAX-5AA0-E00	Warm White	500mA	100	170	--	lm	
ELAR-5DA0-A00	Red	600mA	50	80	--	lm	
ELAT-5AA0-A00	True Green	500mA	100	180	--	lm	
ELAB-5AA0-A00	Blue	500mA	35	60	--	lm	
ELAW-5AA0-D00	Cool White	500mA	90	140	--	lm	CRI : 90
ELAH-5AA0-D00	Neutral White	500mA	50	110	--	lm	CRI : 90
ELAX-5AA0-D00	Warm White	500mA	50	100	--	lm	CRI : 90

### Notes:

1. Flux is measured with an accuracy of  $\pm 10\%$ .
2. All cool white, neutral white, warm white, true green ,and blue emitters are built with InGaN
3. All red emitters are built with AlGaInP

## Forward Voltage Characteristics

The following table describes forward voltage of EdiLine II series under various current.

< Table 5 Forward voltage characteristics at  $T_J=25^{\circ}\text{C}$  for EdiLine II series >

Part Name	Color	Test Current	$V_F$			Unit
			Min.	Typ.	Max.	
ELAW-5AA0-B00	Cool White	500mA	--	--	12.0	V
ELAW-5AA0-D00	Cool White	500mA	--	--	12.0	V
ELAH-5AA0-E00	Neutral White	500mA	--	--	12.0	V
ELAH-5AA0-D00	Neutral White	500mA	--	--	12.0	V
ELAX-5AA0-E00	Warm White	500mA	--	--	12.0	V
ELAX-5AA0-D00	Warm White	500mA	--	--	12.0	V
ELAR-5DA0-A00	Red	600mA	--	--	9.0	V
ELAT-5AA0-A00	True Green	500mA	--	--	12.0	V
ELAB-5AA0-A00	Blue	500mA	--	--	12.0	V

**Note:**

1. Forward Voltage is measured with an accuracy of  $\pm 0.1\text{V}$



## Reliability Items and Failure Measures

### Reliability test

The following table describes operating life, mechanical, and environmental tests performed on EdiLine II series package.

< Table 6 Operating life, mechanical, and environmental characteristics and  $T_J=25^\circ\text{C}$  for EdiLine II series >

Stress Test	Stress Conditions	Stress Duration	Failure Criteria
Room Temperature Operating Life	$25^\circ\text{C}$ , $I_F = \text{max DC}$ (Note 1)	1,000 hours	Note 2
High Temperature High Humidity	$85^\circ\text{C}$ / 85%RH	1,000 hours	Note 2
Thermal Shock	$-40 / 125^\circ\text{C}$ , 15 min dwell / < 10 sec transfer	200 cycles	No catastrophics

#### Notes:

1. Depending on the maximum derating curve.
2. Failure Criteria:
  - Electrical failures
  - $V_F$  shift  $\geq 10\%$
  - Light Output Degradation
  - %  $I_v$  shift  $\geq 30\%$  @1,000hrs or 500cycle
  - Visual failures
  - Broken or damaged package or lead
  - Solderability < 95% wetting
  - Dimension out of tolerance

## Color Spectrum and Radiation Pattern

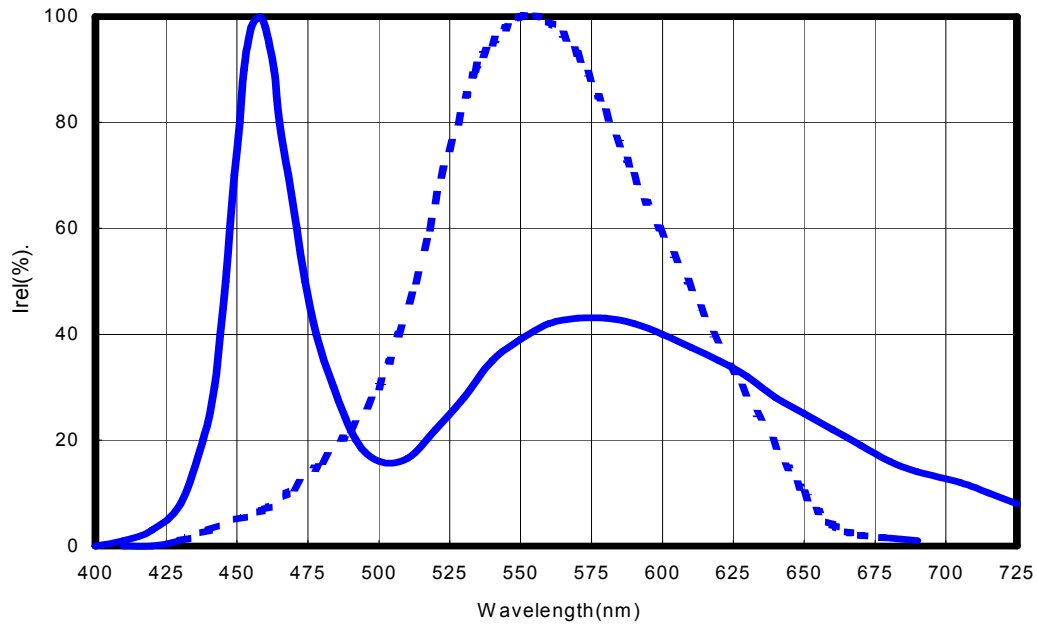

< Figure 2 Color spectrum at  $T_J = 25^\circ\text{C}$  .for EdiLine II series cool white >

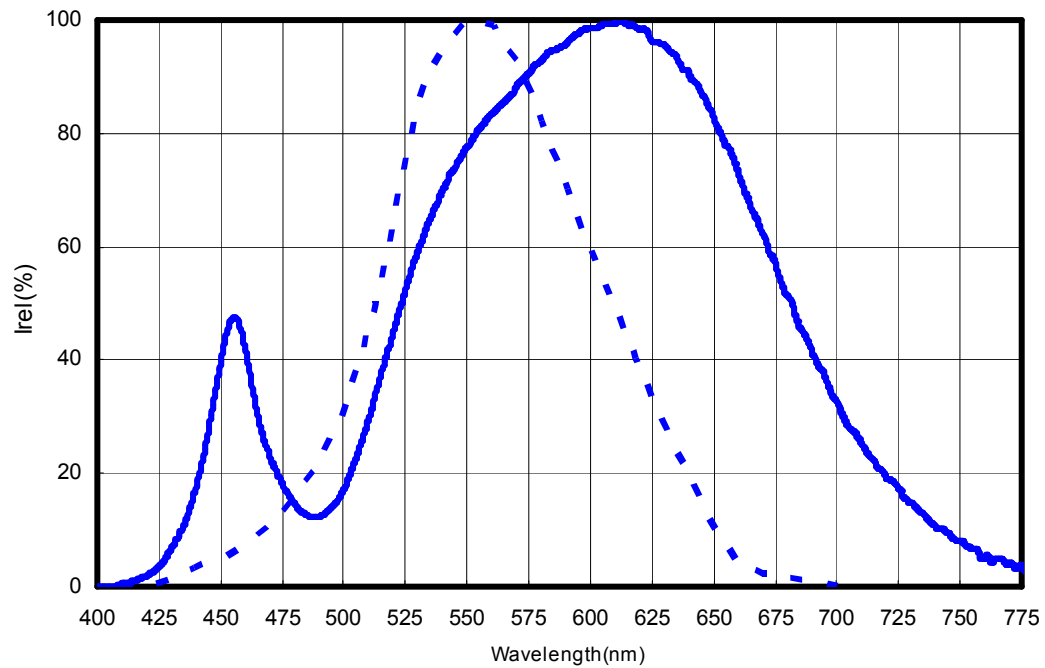

< Figure 3 Color spectrum at  $T_J = 25^\circ\text{C}$  .for EdiLine II series neutral white and warm white >

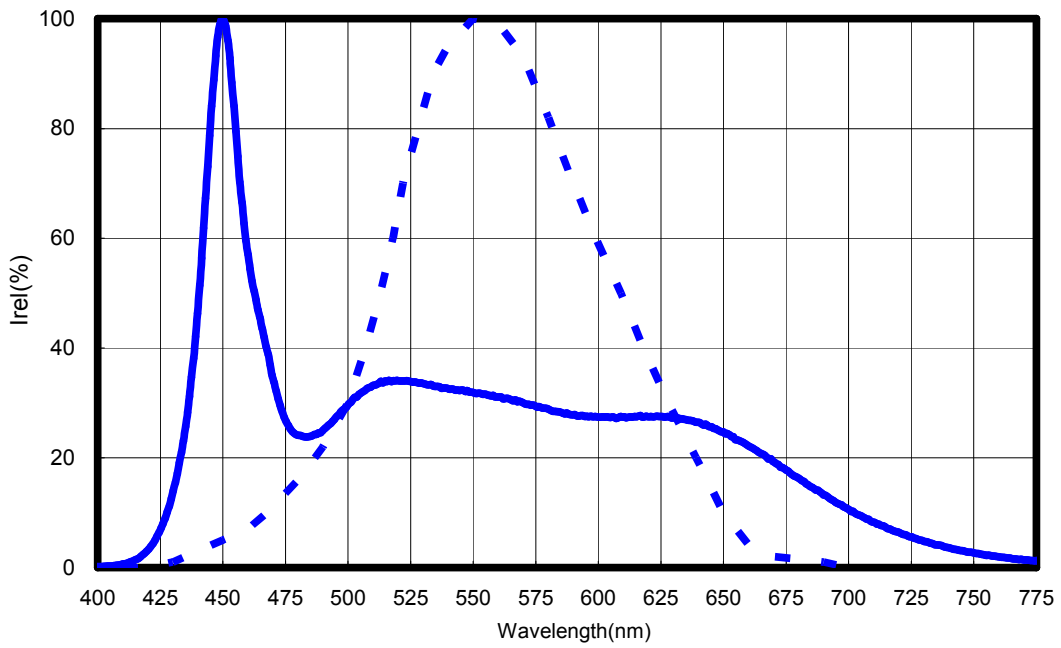

< Figure 4 Color spectrum for EdiLine II series cool white with high CRI >

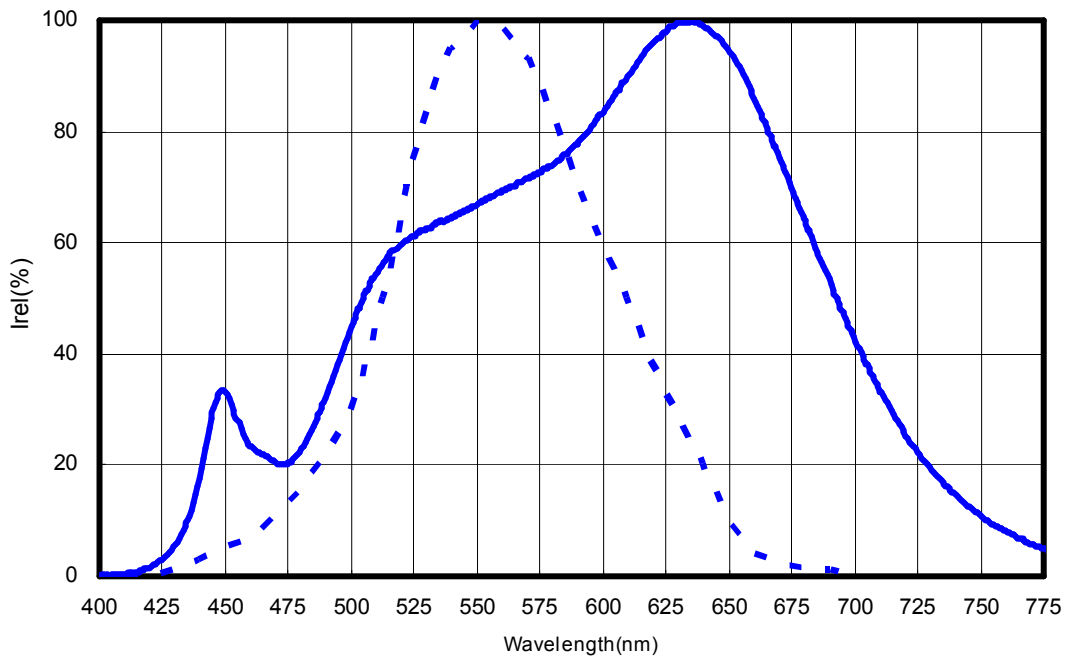

< Figure 5 Color spectrum for EdiLine II series neutral white and warm white with high CRI >

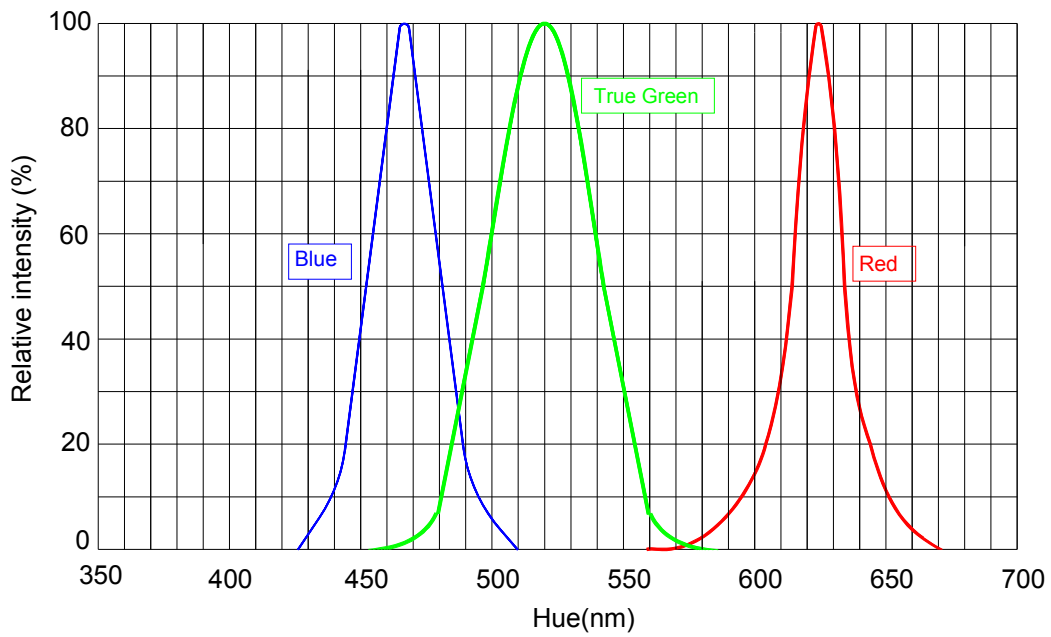

< Figure 6 Color spectrum at  $T_j = 25^\circ\text{C}$  for EdiLine II series red, true green, and blue >

EdiLine II series have two directional radiation patterns.

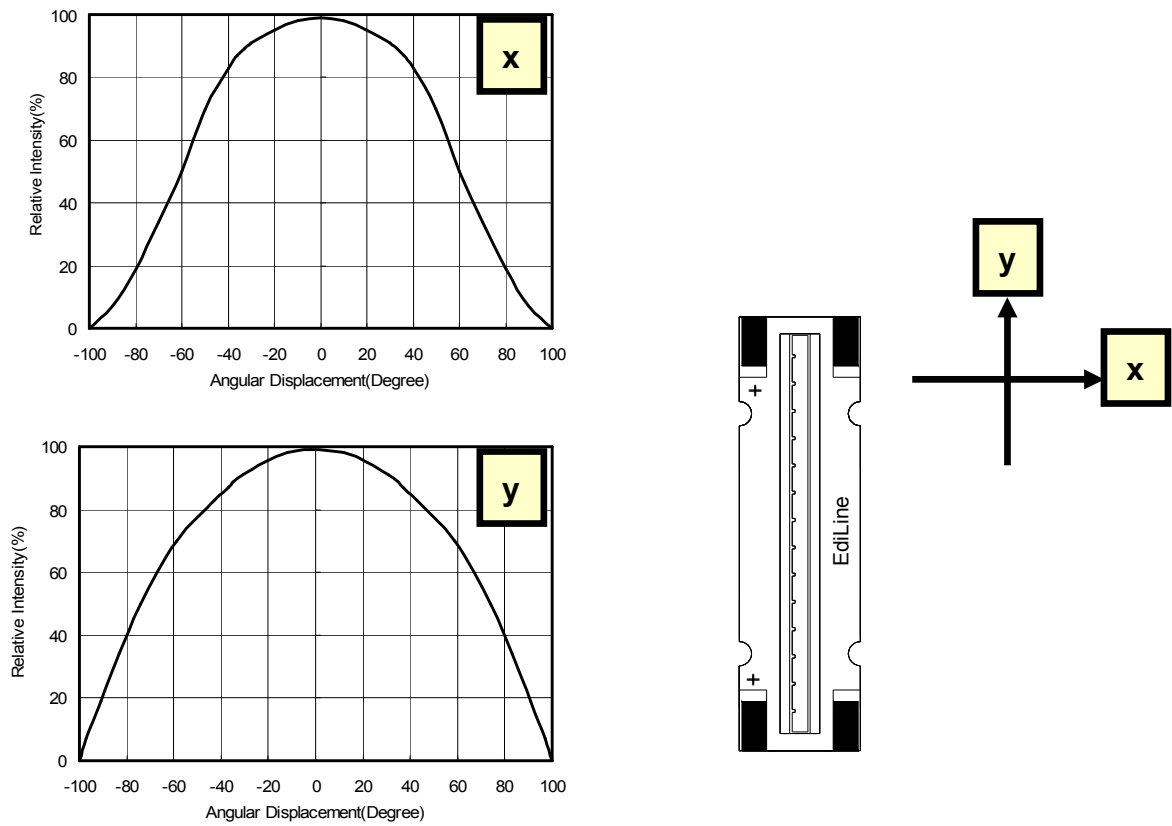

< Figure 7 EdiLine II series at  $T_j = 25^\circ\text{C}$  for red, true green, blue, cool white, neutral white and warm white >

### Emission Angle Characteristics

< Table 7 Emission angle characteristics at  $T_j = 25^\circ\text{C}$  for EdiLine II series >

Part Name	Color	Test Current	$2\theta_{1/2}$ (Typ.)		Unit
			X direction	Y direction	
ELAW-5AA0-B00	Cool White	500mA	120	140	Deg.
ELAW-5AA0-D00	Cool White	500mA	120	140	Deg.
ELAH-5AA0-E00	Neutral White	500mA	120	140	Deg.
ELAH-5AA0-D00	Neutral White	500mA	120	140	Deg.
ELAX-5AA0-E00	Warm White	500mA	120	140	Deg.
ELAX-5AA0-D00	Warm White	500mA	120	140	Deg.
ELAR-5DA0-A00	Red	600mA	120	140	Deg.
ELAT-5AA0-A00	True Green	500mA	120	140	Deg.
ELAB-5AA0-A00	Blue	500mA	120	140	Deg.

### Color Temperature or Dominant Wavelength Characteristics $T_j=25^\circ\text{C}$

< Table 8 Dominant wavelength or peak wavelength or color temperature characteristics at  $T_j = 25^\circ\text{C}$  for EdiLine II series >

Part Name	Color	Test Current	$\lambda_d/\text{CCT}$			Unit
			Min.	Typ.	Max.	
ELAW-5AA0-B00	Cool White	500mA	5,000	--	10,000	K
ELAW-5AA0-D00	Cool White	500mA	5,000	--	10,000	K
ELAH-5AA0-E00	Neutral White	500mA	3,800	--	5,000	K
ELAH-5AA0-D00	Neutral White	500mA	3,800	--	5,000	K
ELAX-5AA0-E00	Warm White	500mA	2,670	--	3,800	K
ELAX-5AA0-D00	Warm White	500mA	2,670	--	3,800	K
ELAR-5DA0-A00	Red	600mA	620	--	630	nm
ELAT-5AA0-A00	True Green	500mA	515	--	535	nm
ELAB-5AA0-A00	Blue	500mA	460	--	475	nm

#### Notes:

1. Wavelength is measured with an accuracy of  $\pm 0.5\text{nm}$
2. CCT is measured with an accuracy of  $\pm 200\text{K}$

## Optical & Electrical Characteristics

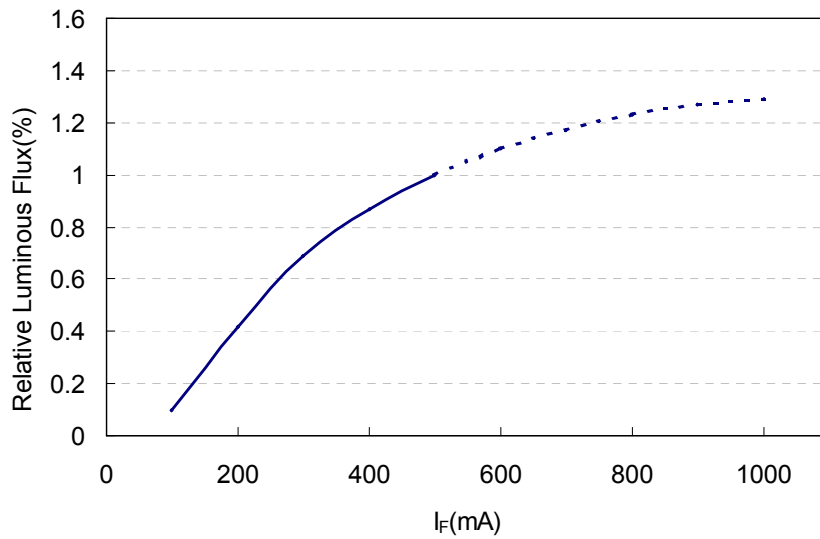

< Figure 8. Relative luminous flux & forward current at  $T_J = 25^\circ\text{C}$  for EdiLine II series >

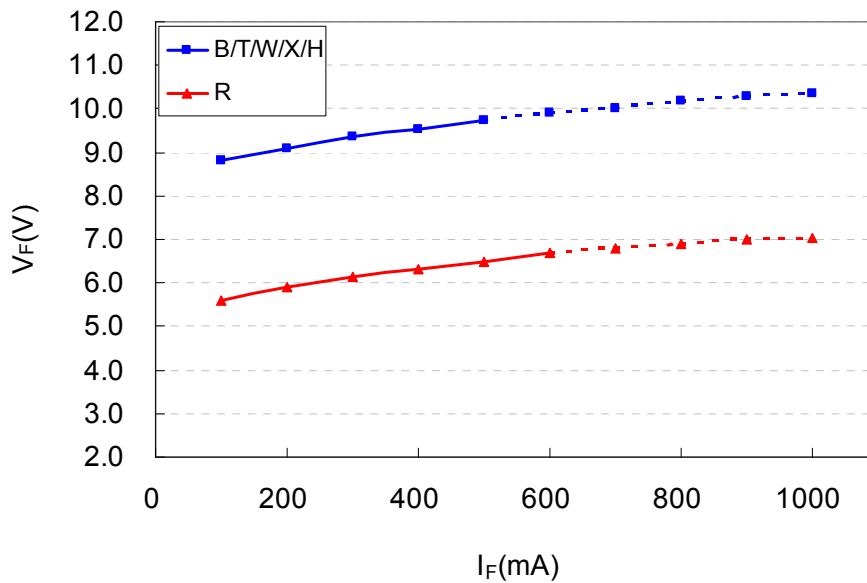

< Figure 9 Forward voltage & forward current at  $T_J = 25^\circ\text{C}$  for EdiLine II series >

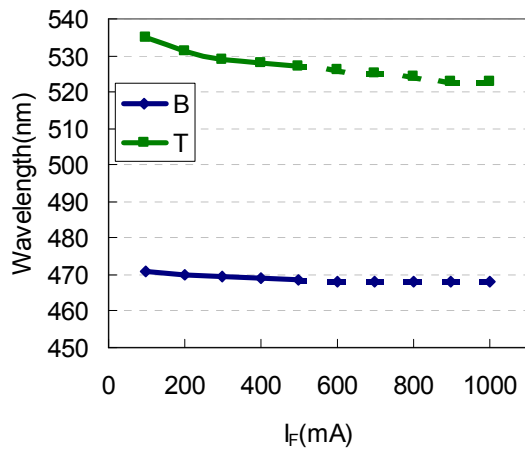

<Figure 10 Forward current & wavelength at  $T_J = 25^\circ\text{C}$  for EdiLine II series blue and true green >

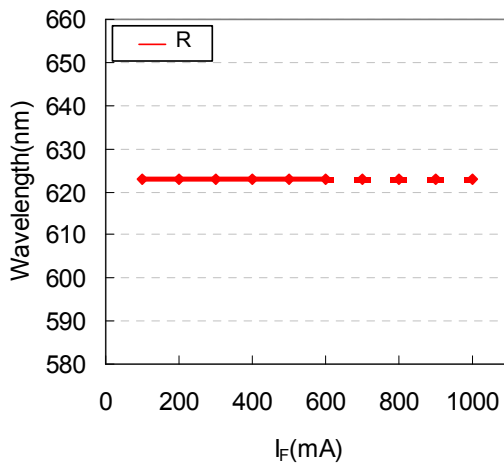

< Figure 11 Forward current & wavelength at  $T_J = 25^\circ\text{C}$  for EdiLine II series red >

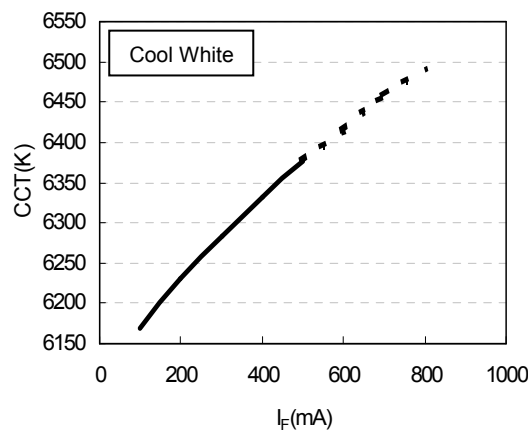

< Figure 12 Forward current & CCT at  $T_J = 25^\circ\text{C}$  for EdiLine II series cool white >

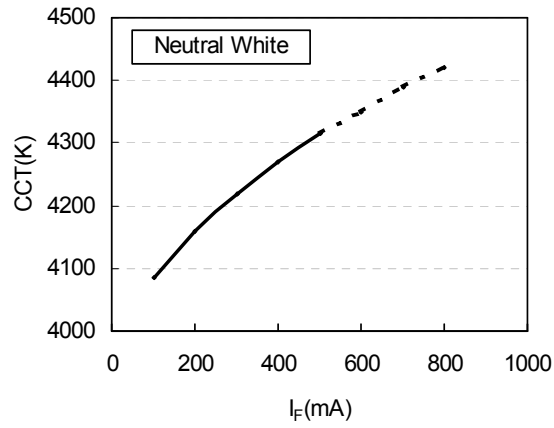

< Figure 13 Forward current & CCT at  $T_J=25^\circ\text{C}$  for EdiLine II series neutral white >

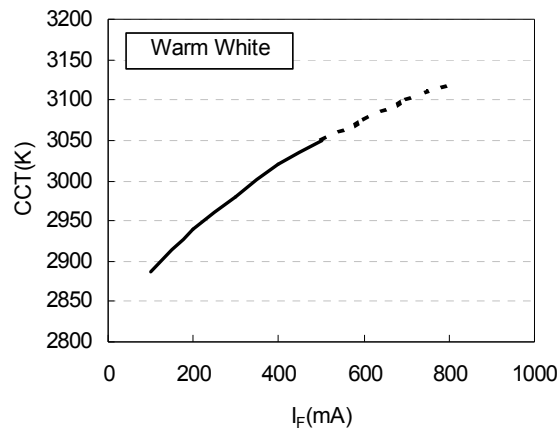

< Figure 14 Forward current & CCT at  $T_J=25^\circ\text{C}$  for EdiLine II series warm white >



### Product Thermal Application Information

Thermal grease should be evenly spreaded with a thickness <math><100\mu\text{m}</math>. When assembling on MCPCB or heatsink carrier.

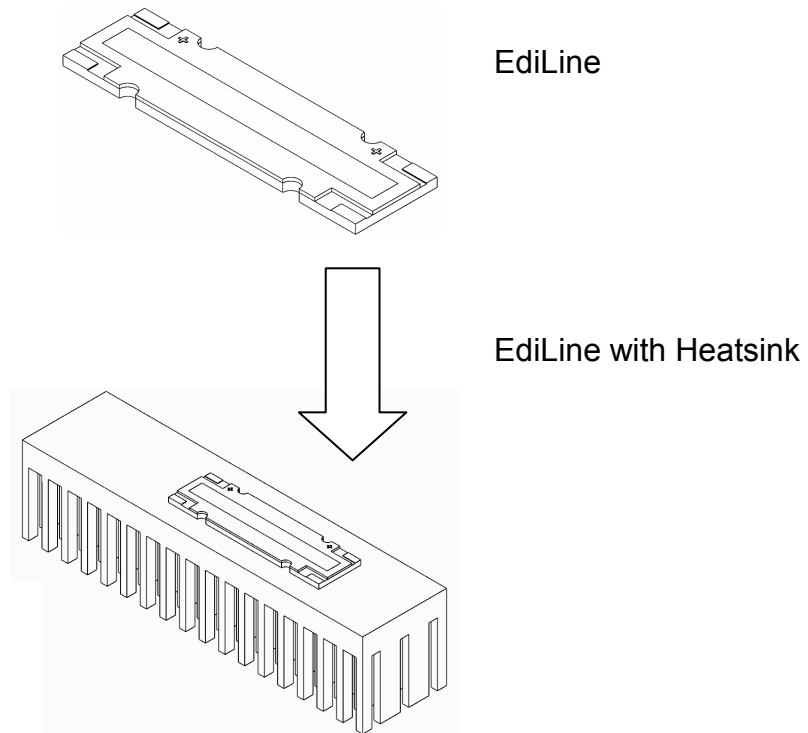

< Figure 15 EdiLine II series heatsink application >

## Thermal Resistance Application

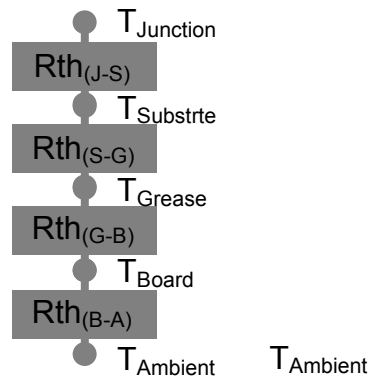

$$R_{th(J-A)} = R_{th(J-S)} + R_{th(S-G)} + R_{th(G-B)} + R_{th(B-A)}$$

$$T_{Junction} = T_{Ambient} + R_{th(J-A)} \times P_{Dissipation}$$

$$(T_J = T_A + R_{th(J-A)} \times P_{Dissipation})$$

< Figure 16 Rth and Tj for EdiLine >

## Suggested Adhesive for Selection(such as thermal grease)

- Ease of use
  - Non-solvent, One-part
- Fast tack free
  - 3 minutes at 25°C
- No corrosion
  - Alcohol type of room temperature vulcanization (RTV)
- Low volatility
  - Low weight loss of silicone volatiles
- Adhesion
  - Excellent adhesion to most materials without use of a primer
- Dielectric properties
  - Cured rubber exhibits good dielectric properties
- Excellent thermal stability and cold resistance
  - Cured rubber provides wide service temperature range

< Table 14 Specification for adhesive properties >

Specification	Suggested Properties
Take-free time	3~10 minutes
Specific gravity	< 3 g/cm <sup>2</sup>
Thermal conductivity	> 2.5 W/mK
Rth in using	< 1.8 °C/W
Volume resistance	> 1x10 <sup>14</sup>
Lap shear adhesion strength	> 200 N/ cm <sup>2</sup>
Tensile strength	> 4 Mpa

## Product Electrical Application Information

Following graphs and descriptions show how to connect LED or LED module and plug to AC outlet.

Step1: Connect the wires of LED Module to the DC output of the driver.

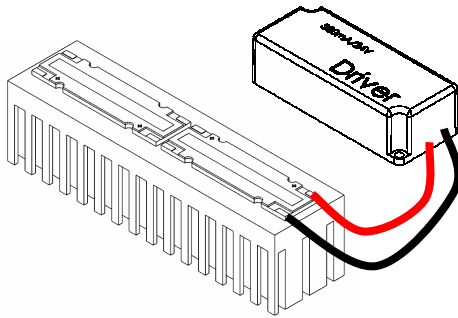

< Figure 17 LED Module connect to the DC output of the driver >

Step2 : Plug the driver to AC outlet.

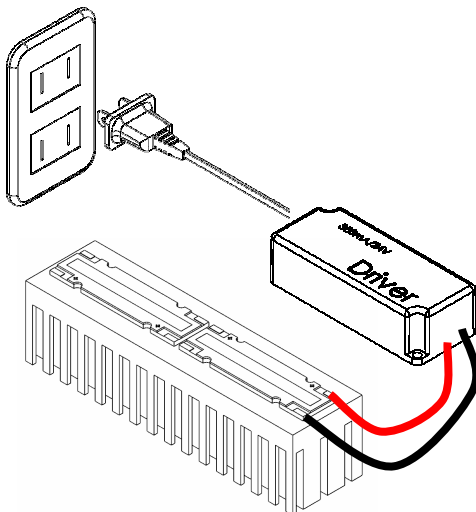

< Figure 18 Plug the AC output of the driver to AC outlet >

**Caution:** Never plug the driver to AC outlet before the LED Module is properly connected as this may generate transient voltage damage the LEDs permanently with a short or open circuit.

## Product Packaging Information

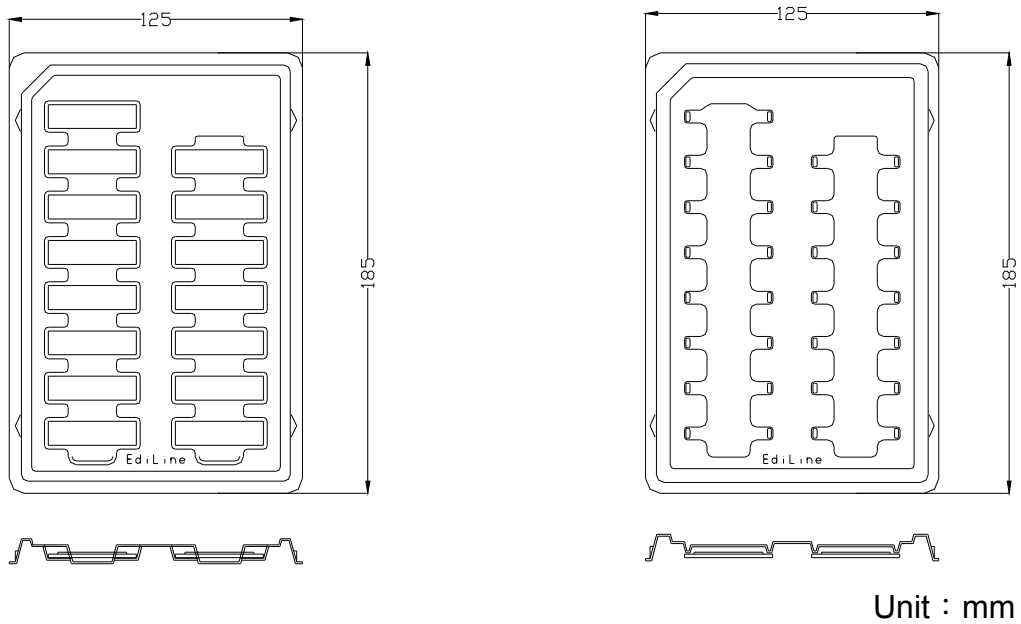

< Figure 19 Tray package dimensions >

### Notes:

1. There are 15pcs emitters in a tray package.
2. Package storage condition will be limited in temperature 20~30°C RH 40~50%

**Package Step**

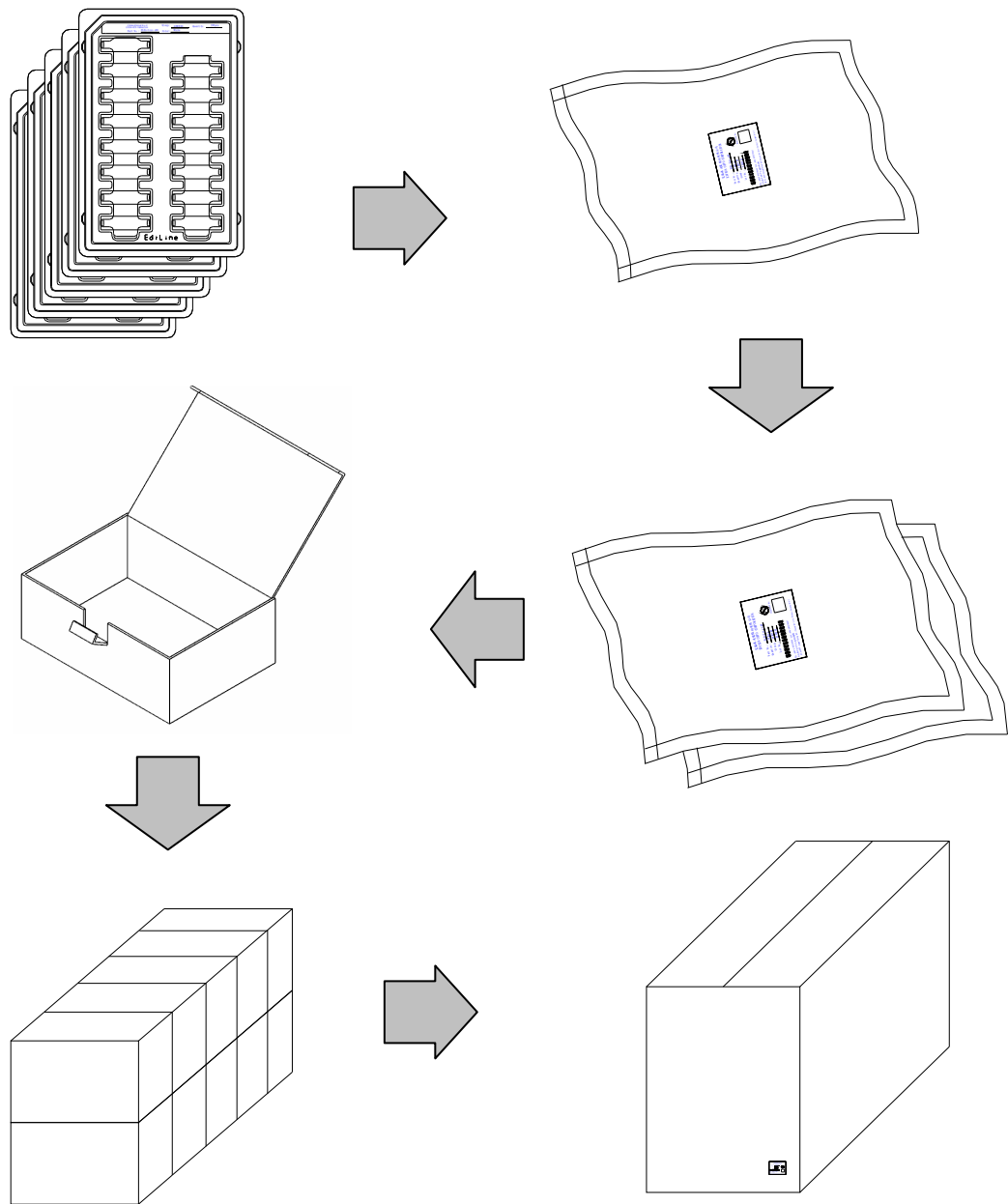

< Figure 20 Package steps >

< Table 15 Package dimensions and quantity >

Item	Quantity	Total	Dimensions(mm)
Tray	15 pcs/tray	15 pcs	125*185*9.3
ESD Shielding Bag	5 trays/bag	75 pcs	200*330*0.1
Inner Box	2 bags/box	150 pcs	240*170*95
Outer Box	10 inner boxes/outer box	1,500 pcs	488*260*36.4