

## Introduction

The ISL97634 is a white LED driver with high frequency PWM dimming capability.

Jumpers JP1 to JP5 can be optionally used to disable five of the seven LEDs. The ISL97634 is guaranteed to drive six LEDs (3.5V/30mA type). It is possible to drive seven LEDs at 20mA if the total VF is lower than the OVP threshold and the input voltage is at nominal rather than low level.

Jumper S3 is used to connect the FBSW that must be connected with the center and upper pins.

Jumper S4 is used to select the RSet as either a 4.75Ω resistor R1 or a 100Ω potentiometer, R2. If R1 is used, connect S4 with the center and the left most pins. This resistance sets the LED supply current.

$$I_{LED} = 95mV/R_{set} * PWM \quad (EQ. 1)$$

where PWM is the PWM duty cycle.

## Steps for Setting up the Demo Board:

1. Apply a DC power voltage source 2.7V to 5.5V in  $V_{IN}$ . Due to the boost function, the input DC voltage must be lower than the output voltage in order to regulate the output LED current.
2. Use R1 or R2 to set the desirable LED peak current.
3. Apply a PWM signal at PWM/EN to achieve the desirable current and LED brightness.

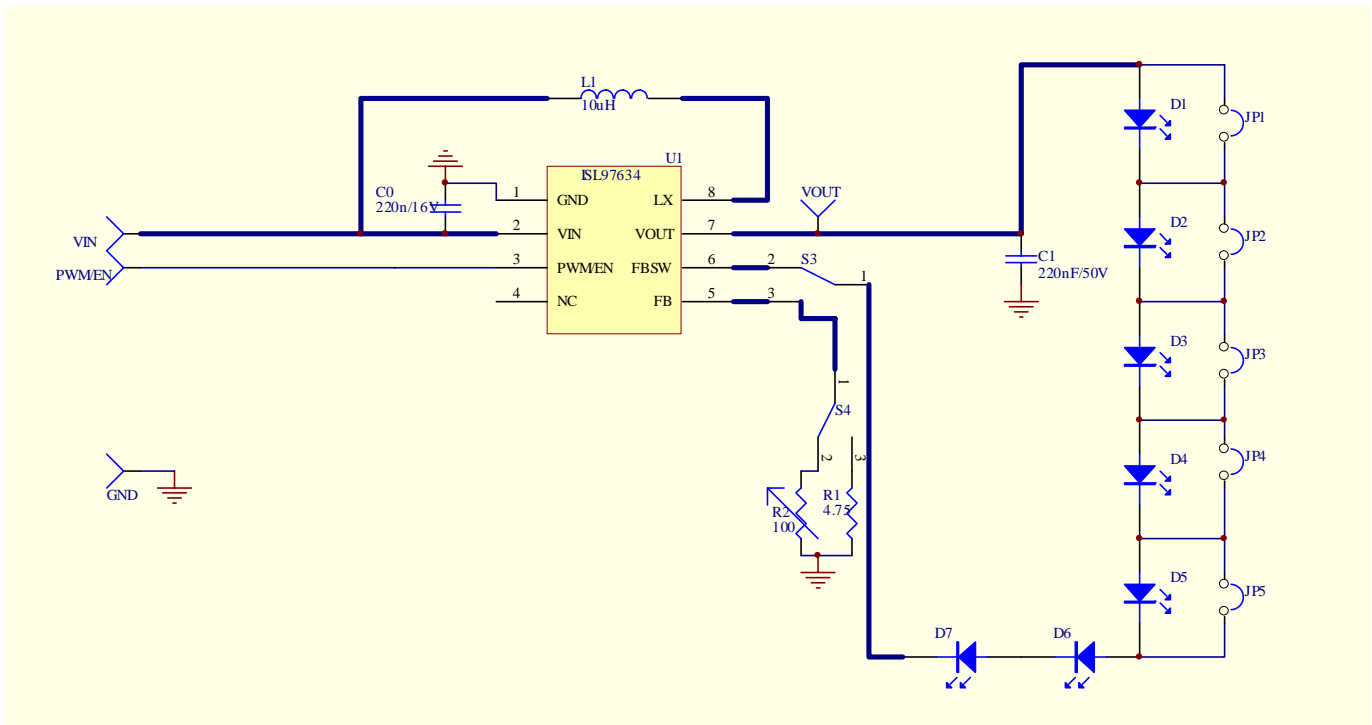

FIGURE 1. SCHEMATIC OF ISL97634 DEMO BOARD

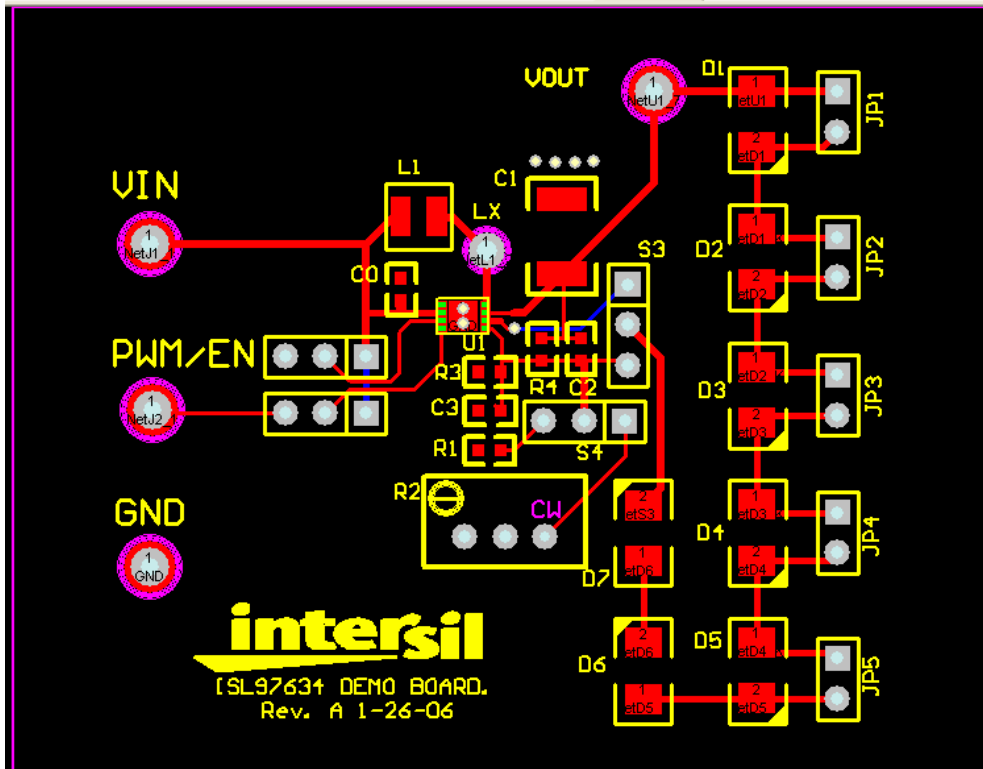

FIGURE 2. SCHEMATIC OF ISL97634 DEMO BOARD

## Technical Brief 470

**TABLE 1. ISL97634 DEMO BOARD BOM**

ITEM	QTY	REF	DESCRIPTION	VENDOR	PART NO.	PACKAGE
1	1	C2	1nF/50V			0603
2	1	R1	4.75			0603
3	1	L1	22 $\mu$ H	Coilcraft	1008PS-223KL	3.81mmx3.81mm
			10 $\mu$ H	Coilcraft	1008PS-103KL	3.81mmx3.81mm
4	1	R3	20k			0603
5	1	C3	33nF/50V			0603
6	1	R2	100			0603
7	1	C0	220n/16V			0603
8	1	C1	4.7 $\mu$ F/50V	Murata	GRM32ER71H475KA88	1210
9	1	R4	698k			0603
10	1	J3	GND			POWERPOST
11	1	U1	LED Driver	Intersil	ISL97634	TDFN2X3
12	1	JP3	JUMPER			JUMPER-2PIN
13	1	JP4	JUMPER			JUMPER-2PIN
14	1	JP5	JUMPER			JUMPER-2PIN
15	1	JP2	JUMPER			JUMPER-2PIN
16	1	JP1	JUMPER			JUMPER-2PIN
17	1	J2	SDIN			POWERPOST
18	1	J1	VIN			POWERPOST
19	1	J4	VOUT			POWERPOST
20	7	D1 to D7	LED	OSRAM	LW Y3SG	0.6mm MircoSIDLED

*Intersil Corporation reserves the right to make changes in circuit design, software and/or specifications at any time without notice. Accordingly, the reader is cautioned to verify that the Application Note or Technical Brief is current before proceeding.*

For information regarding Intersil Corporation and its products, see [www.intersil.com](http://www.intersil.com)