

Kingbright

P 2	SIDE VIEW
P 3	CLUSTER
P 4-5	BASED LED LAMPS

2007-2009

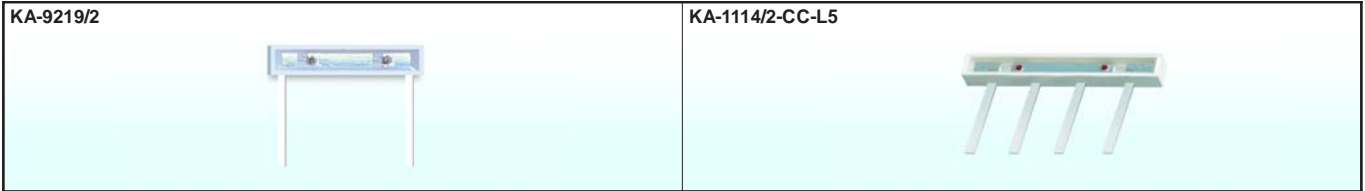

Part No.	Material	λ D (nm)	Lens Type	Iv (mcd) @20mA		Viewing Angle 2θ1/2	Dimension
				Min.	Typ.		
KA-9219/2EC	GaAsP/GaP	625	water clear	18	50	100°	9.2mm x 1.9mm
KA-9219/2SRC	GaAlAs	640	water clear	70	200	100°	
KA-9219/2YC	GaAsP/GaP	588	water clear	10	20	100°	
KA-9219/2SGC	GaP	568	water clear	7	40	100°	
KA-1114/2EC-CC-L5	GaAsP/GaP	625	water clear	4	9	120°	11mm x 1.4mm
KA-1114/2YC-CC-L5	GaAsP/GaP	588	water clear	4	10	120°	
KA-1114/2SYC-CC-L5	InGaAlP	588	water clear	50	100	120°	
KA-1114/2SGC-CC-L5	GaP	568	water clear	7	16	120°	
KA-1114/2QBC-D-CC-L5	GaN	470	water clear	70	130	120°	
KA-1114/2PBC-A-CC-L5	InGaN	470	water clear	36	100	120°	

NOTES:

1. All dimensions are in millimeters(inches).
2. Tolerance is ±0.25mm(0.01") unless otherwise noted.



Part No.	Material	λ D (nm)	Lens Type	Iv (mcd)		Viewing Angle	IF(mA)
				Min.	Typ.		
BL0508-09-73	GaAlAs	640	water clear	480	1200	40°	20
	GaP	568	water clear	380	800	40°	40

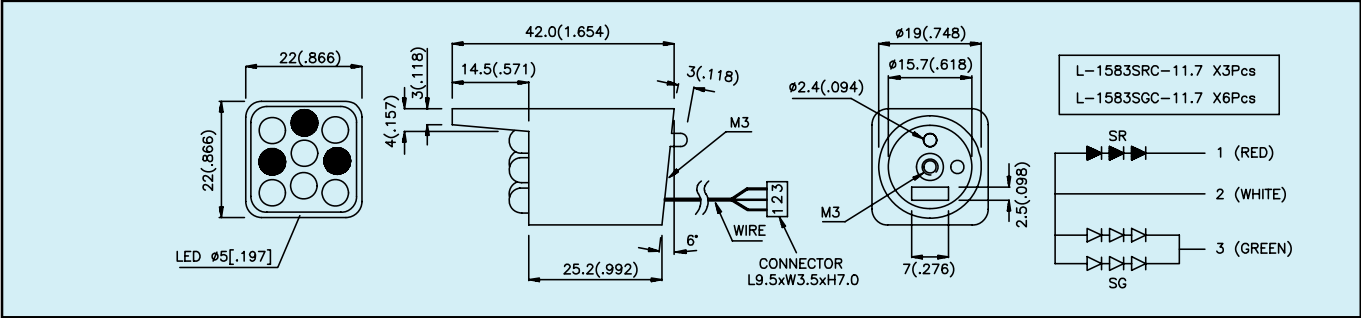

BL0102-14-34	GaAlAs	640	water clear	1500	2800	40°	20
	GaP	568	water clear	650	1600	40°	40

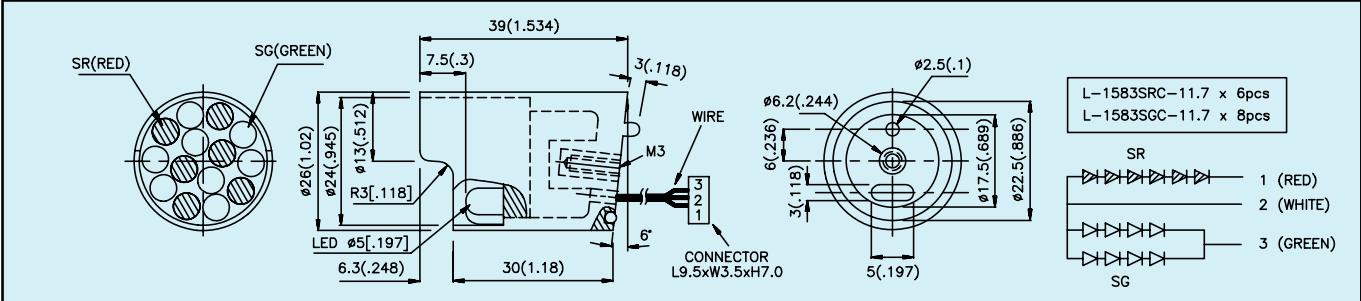

BL0307-50-44	GaAlAs	640	water clear	12000	21000	40°	200
--------------	--------	-----	-------------	-------	-------	-----	-----

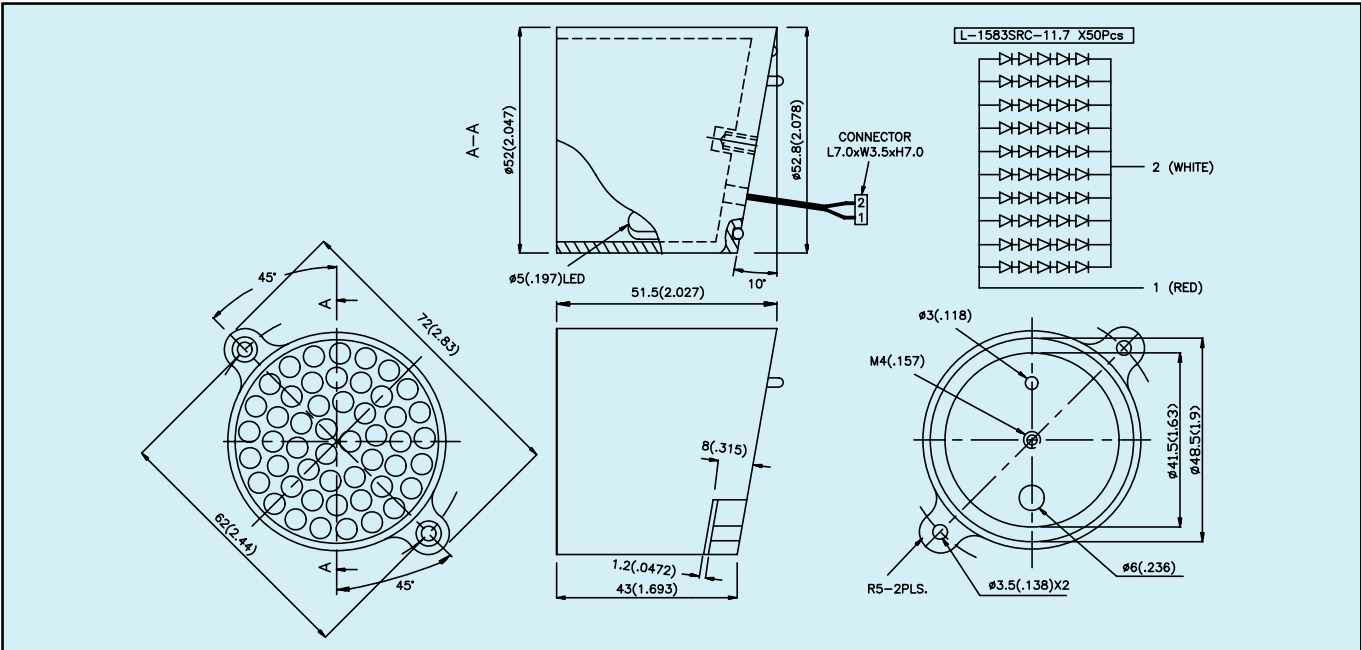

NOTES:
 1. All dimensions are in millimeters(inches).
 2. Tolerance is ±0.25mm(0.01") unless otherwise noted.



Part No.	Material	λ D (nm)	Lens Type	Iv (mcd) V=6V		Viewing Angle	Dimension
				*V=12V Min.	**V=28V Typ.		

BLF051SURC-E-6V-P	InGaAlP	630	water clear	650	1500	30°	5mm Flange Base
BLF051SURC-E-12V-P	InGaAlP	630	water clear	*480	*1200	30°	
BLF051SURC-E-28V-P	InGaAlP	630	water clear	**380	**1000	30°	
BLF051SYC-6V-P	InGaAlP	588	water clear	280	500	30°	
BLF051SYC-12V-P	InGaAlP	588	water clear	*180	*400	30°	
BLF051SYC-28V-P	InGaAlP	588	water clear	**110	**230	30°	
BLF051MGC-6V-P	InGaAlP	568	water clear	280	400	30°	
BLF051MGC-12V-P	InGaAlP	568	water clear	*180	*300	30°	
BLF051MGC-28V-P	InGaAlP	568	water clear	**110	**220	30°	

BLF052SURC-E-6V-P	InGaAlP	630	water clear	900	1200	45°	5mm Flange Base
BLF052SURC-E-12V-P	InGaAlP	630	water clear	*650	*1000	45°	
BLF052SURC-E-28V-P	InGaAlP	630	water clear	**480	**800	45°	
BLF052SYC-6V-P	InGaAlP	588	water clear	280	400	45°	
BLF052SYC-12V-P	InGaAlP	588	water clear	*180	*300	45°	
BLF052SYC-28V-P	InGaAlP	588	water clear	**110	**250	45°	
BLF052MGC-6V-P	InGaAlP	568	water clear	180	400	45°	
BLF052MGC-12V-P	InGaAlP	568	water clear	*110	*300	45°	
BLF052MGC-28V-P	InGaAlP	568	water clear	**70	**200	45°	

BLB101SURC-E-6V-P	InGaAlP	630	water clear	900	2200	20°	10mm Bayonet Base
BLB101SURC-E-12V-P	InGaAlP	630	water clear	*650	*1800	20°	
BLB101SURC-E-28V-P	InGaAlP	630	water clear	**480	**930	20°	
BLB101SYC-6V-P	InGaAlP	588	water clear	650	1300	20°	
BLB101SYC-12V-P	InGaAlP	588	water clear	*480	*1200	20°	
BLB101SYC-28V-P	InGaAlP	588	water clear	**180	**380	20°	
BLB101MGC-6V-P	InGaAlP	568	water clear	380	900	20°	
BLB101MGC-12V-P	InGaAlP	568	water clear	*280	*800	20°	
BLB101MGC-28V-P	InGaAlP	568	water clear	**110	**300	20°	

NOTES:

1. All dimensions are in millimeters(inches).
2. Tolerance is ±0.25mm(0.01") unless otherwise noted.

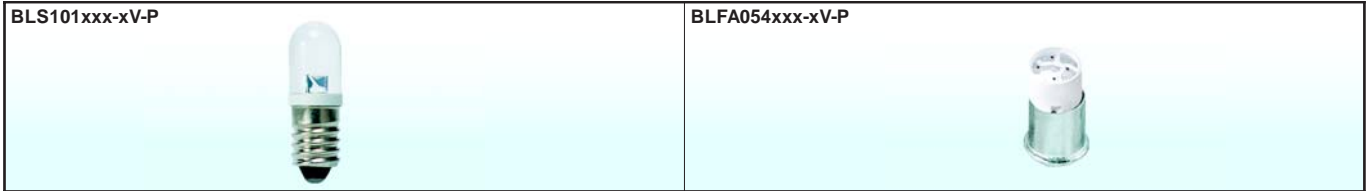

Part No.	Material	λ D (nm)	Lens Type	Iv (mcd) V=6V		Viewing Angle	Dimension
				*V=12V	**V=28V		

							10mm Screw Base
BLS101SURC-E-6V-P	InGaAlP	630	water clear	900	2200	20°	
BLS101SURC-E-12V-P	InGaAlP	630	water clear	*650	*1800	20°	
BLS101SURC-E-28V-P	InGaAlP	630	water clear	**480	**900	20°	
BLS101SYC-6V-P	InGaAlP	588	water clear	650	1300	20°	
BLS101SYC-12V-P	InGaAlP	588	water clear	*480	*1200	20°	
BLS101SYC-28V-P	InGaAlP	588	water clear	**280	**350	20°	
BLS101MGC-6V-P	InGaAlP	568	water clear	380	900	20°	
BLS101MGC-12V-P	InGaAlP	568	water clear	*280	*800	20°	
BLS101MGC-28V-P	InGaAlP	568	water clear	**110	**350	20°	

							5mm Flange Base
BLFA054SURCK-6V-P	InGaAlP	635	water clear	280	510	110°	
BLFA054SURCK-12V-P	InGaAlP	635	water clear	*280	*510	110°	
BLFA054SURCK-28V-P	InGaAlP	635	water clear	**280	**510	110°	
BLFA054SECK-6V-P	InGaAlP	601	water clear	380	760	110°	
BLFA054SECK-12V-P	InGaAlP	601	water clear	*380	*760	110°	
BLFA054SECK-28V-P	InGaAlP	601	water clear	**380	**760	110°	
BLFA054SYCK-6V-P	InGaAlP	590	water clear	36	130	110°	
BLFA054SYCK-12V-P	InGaAlP	590	water clear	*36	*130	110°	
BLFA054SYCK-28V-P	InGaAlP	590	water clear	**36	**130	110°	
BLFA054MGCK-6V-P	InGaAlP	570	water clear	180	460	110°	
BLFA054MGCK-12V-P	InGaAlP	570	water clear	*180	*460	110°	
BLFA054MGCK-28V-P	InGaAlP	570	water clear	**180	**460	110°	
BLFA054PBC-A-6V-P	InGaN	470	water clear	70	200	110°	
BLFA054PBC-A-12V-P	InGaN	470	water clear	*70	*180	110°	
BLFA054PBC-A-28V-P	InGaN	470	water clear	**28	**60	110°	

NOTES:

- All dimensions are in millimeters (inches).
- Tolerance is ±0.25mm (0.01") unless otherwise noted.