



TECHNICAL SPECIFICATION

pixiLED

PX-1A545-B



High luminous intensity SMD-Top View LED
Color: Blue

1. FEATURES

- **Package:** High reliability PLCC-2 package
- **Technology:** Toyoda Gosei InGaN core emitter 
- **Molding:** Long life with **Silicone** encapsulation
- **Chromatic coordinate groups:** High precision single rank selection
- **Luminous intensity:** typ. 160 mcd at 20 mA
- **Viewing angle:** 120° lambertian emitter
- **Assembly methods:** Suitable for all standard SMD mounting
- **RoHS** Compliant
- **Lead (Pb)** Free Product

2. TYPICAL APPLICATIONS

- Decoration lighting
- Ambience & general lighting
- Amusement Machines
- Display
- Backlighting



3. Absolute Maximum Ratings

Ta=25°C

Parameter	Symbol	Value	Unit
Power Dissipation	P_D	120	mW
DC Forward Current	I_F	30	mA
Pulsed Forward Current	I_{FP} ^{Note 1}	100	mA
DC Reverse Voltage	V_R	5	V
Operating Temperature	T_{op}	-40 ~ +100	°C
Storage Temperature	T_{stg}	-40 ~ +100	°C
Junction Temperature	T_j	120	°C
Soldering Temperature	T_{sld}	See section 5 for details	

Note 1: I_{FP} is tested in with 1 msec pulse width of duty 10%.

Allowable Forward Current vs Ambient Temperature

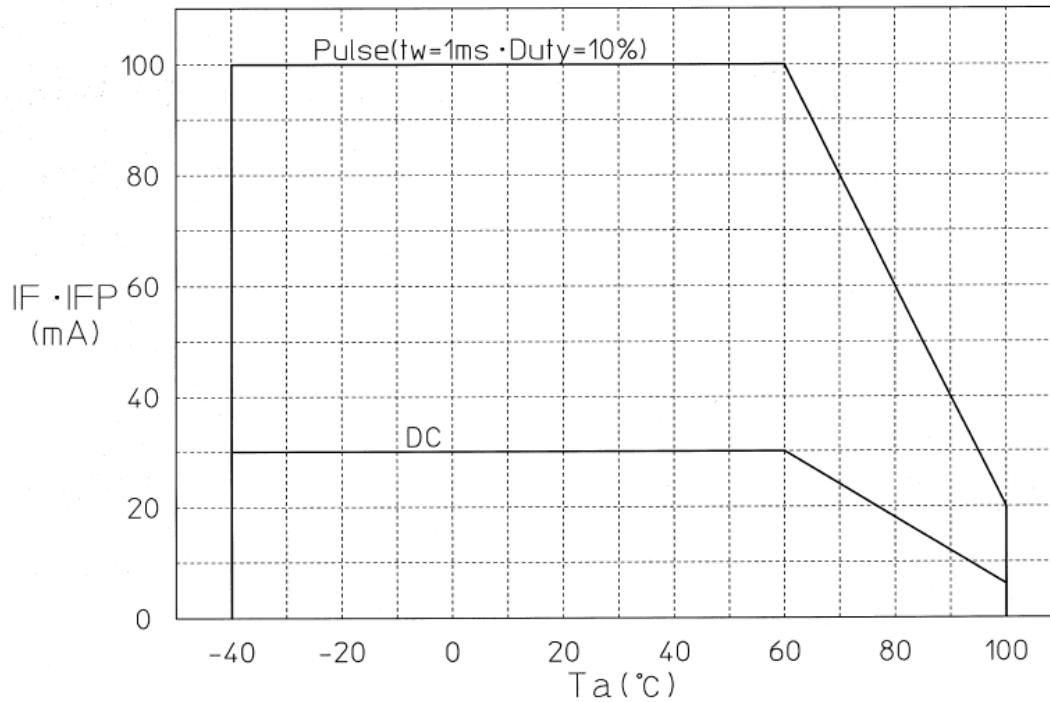



4. Electro-Optical Characteristics

Ta=25°C

Parameter	Symbol	Condition	min	typ	max	Unit
Forward Voltage	V_F	$I_F=20\text{mA}$	2.7	3.3	3.7	V
Reverse Current	I_R	$V_R=5\text{V}$	-	-	10	μA
Luminous Intensity, white (axial direction)	$I_V^{\text{Note 2}}$	$I_F=20\text{mA}$	-	160	-	mcd
Dominant Wavelength	λ_d	$I_F=20\text{mA}$	455	460	465	nm
Spectrum width of half value	$\Delta\lambda$	-	-	25	-	nm

Note 2: Following ranks are applied for Luminous Intensity ($I_F = 20\text{mA}$, $T_a=25^\circ\text{C}$)

Rank	Luminous Intensity (mcd)
J	120 ~ 180
K	180 ~ 270
L	270 ~ 390

Guaranteed performance including error of luminous intensity measurement is 10% of above table value.



Reference Curves (typical values)

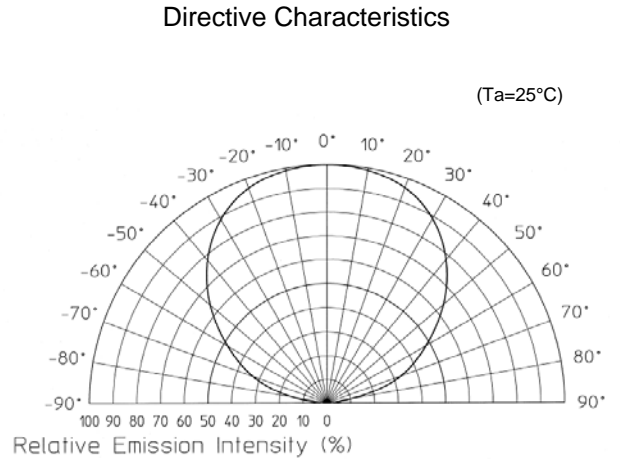
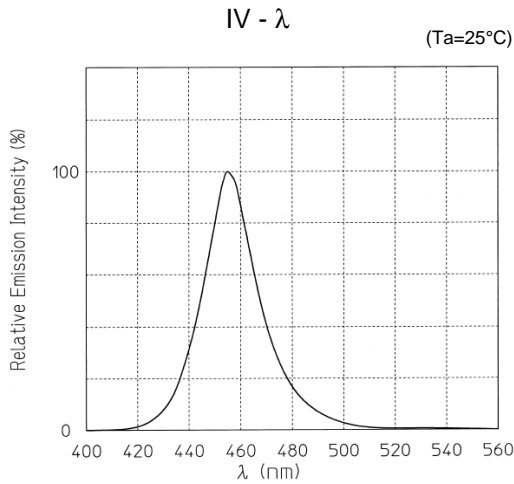
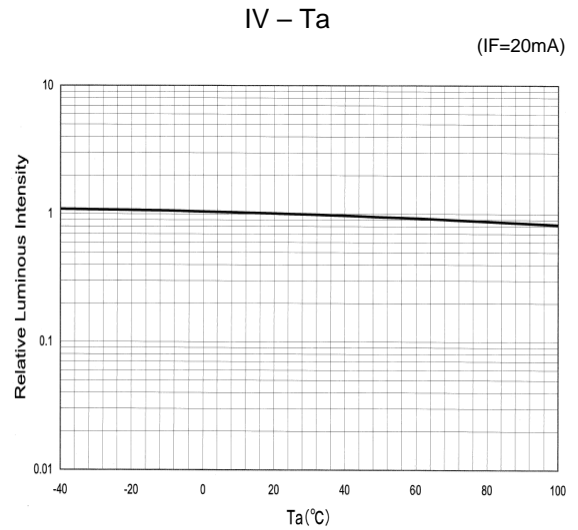
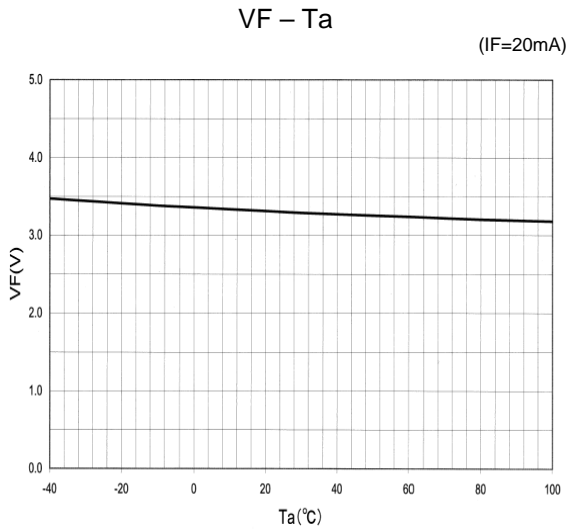
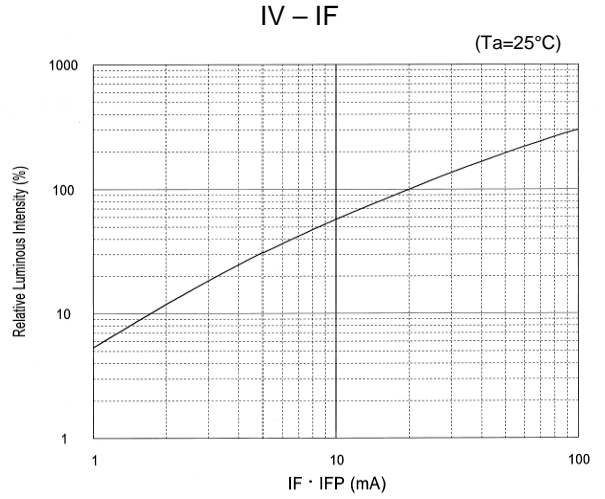
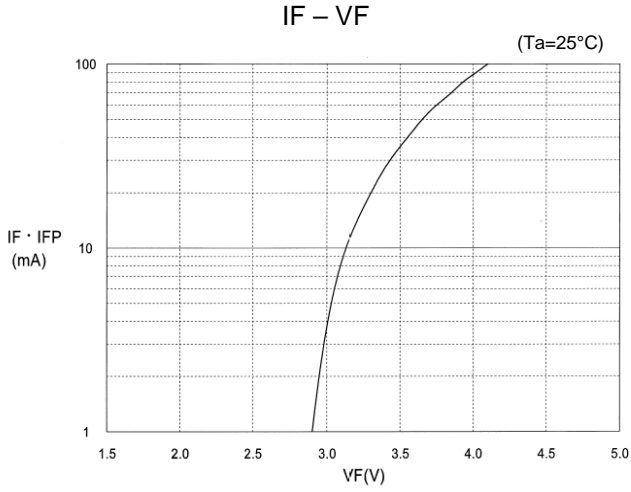

5. Soldering Guidelines

- Soldering paste and optical layer must not come into contact. This could affect the performance of the component.
- Do not exert external pressure on any part of the resin when soldering.
- The component should be cooled to room temperature before further processing.
- This product is not suitable for wave soldering. Use reflow solder or use a hot plate when soldering. Soldering under N₂-atmosphere is recommended to maintain reliability.
- Soldering rework is not recommended.
- Do not implement multiple reflow methods.
- After soldering, do not bend the circuit board.

5.1 Solder Pad / Footprint

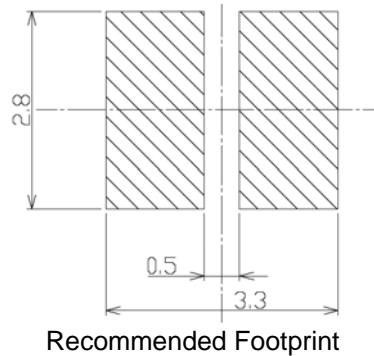

5.2 Reflow Soldering Conditions / Profile

- Preheat to be at maximum 160°C for maximum 2 minutes.
- Soldering temperature should not exceed 260°C for maximum 5 seconds.

Recommended soldering conditions (surface of circuit board) –lead-free solder

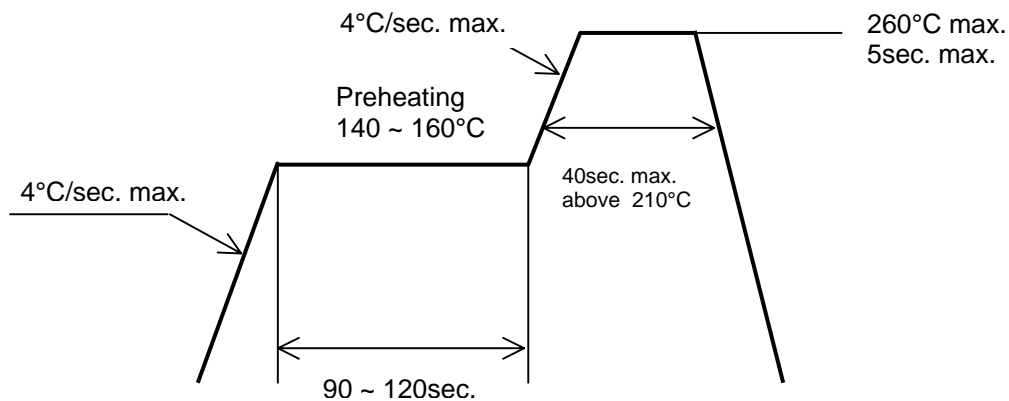



- Please check the mounting reliability based on the application.
- Excessive coating of solder paste on the board may result in the formation of a “Solder Ball” on the board and/ or on the side surface of the LED after reflow. Customer should take note that the “Solder Ball” may cause a short circuit.

5.3 Others

- The LEDs described in this brochure are intended for ordinary electronic equipment such as office equipment, communications equipment, measurement instruments and household appliances. Consult LEXEDIS sales staff in advance for information on the applications in which exceptional quality and reliability are required, particularly when the failure or malfunction of the LEDs may directly harm life or health (such as for airplanes, aerospace, submersible repeaters, nuclear reactor control systems, automobiles, traffic control equipment, life support systems and safety devices).
- User shall not reverse engineer by disassembling or analysis of the LEDs without having prior written consent from LEXEDIS. In the rare occurrence that LEDs are found faulty, the user shall inform LEXEDIS directly before disassembling or analysis.
- The formal specifications (including verification- and validation-program) must be agreed and signed by both parties prior to large volume purchase begins.
- The appearance and specifications of the product may be modified for improvement without prior notice.

6. Outline Dimensions / Electrical Schematic

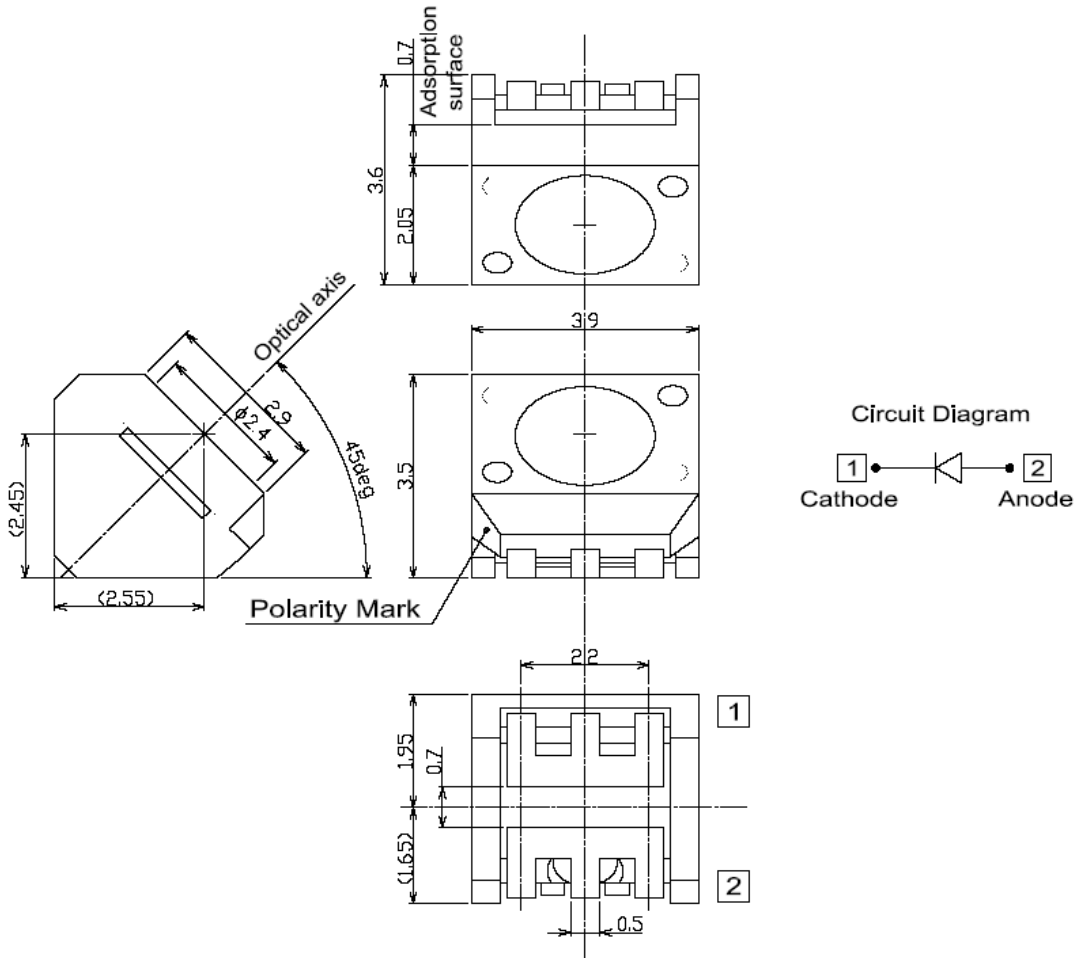

Item	Material
Encapsulating	Silicone resin

7. Packing

- Quantity is 1500pcs/reel
- The reel is packed in an antistatic plastic pack.
- The LEDs are packaged in cardboard boxes for transportation.
- The packages should be handled carefully to avoid damage of the components.
- The boxes are not waterproof and therefore must be protected from water and moisture.
- When the LEDs are transported, we recommend that you use the same packing method as LEXEDIS.

7.1 Reel Packing Structure (Reel ϕ 330mm)

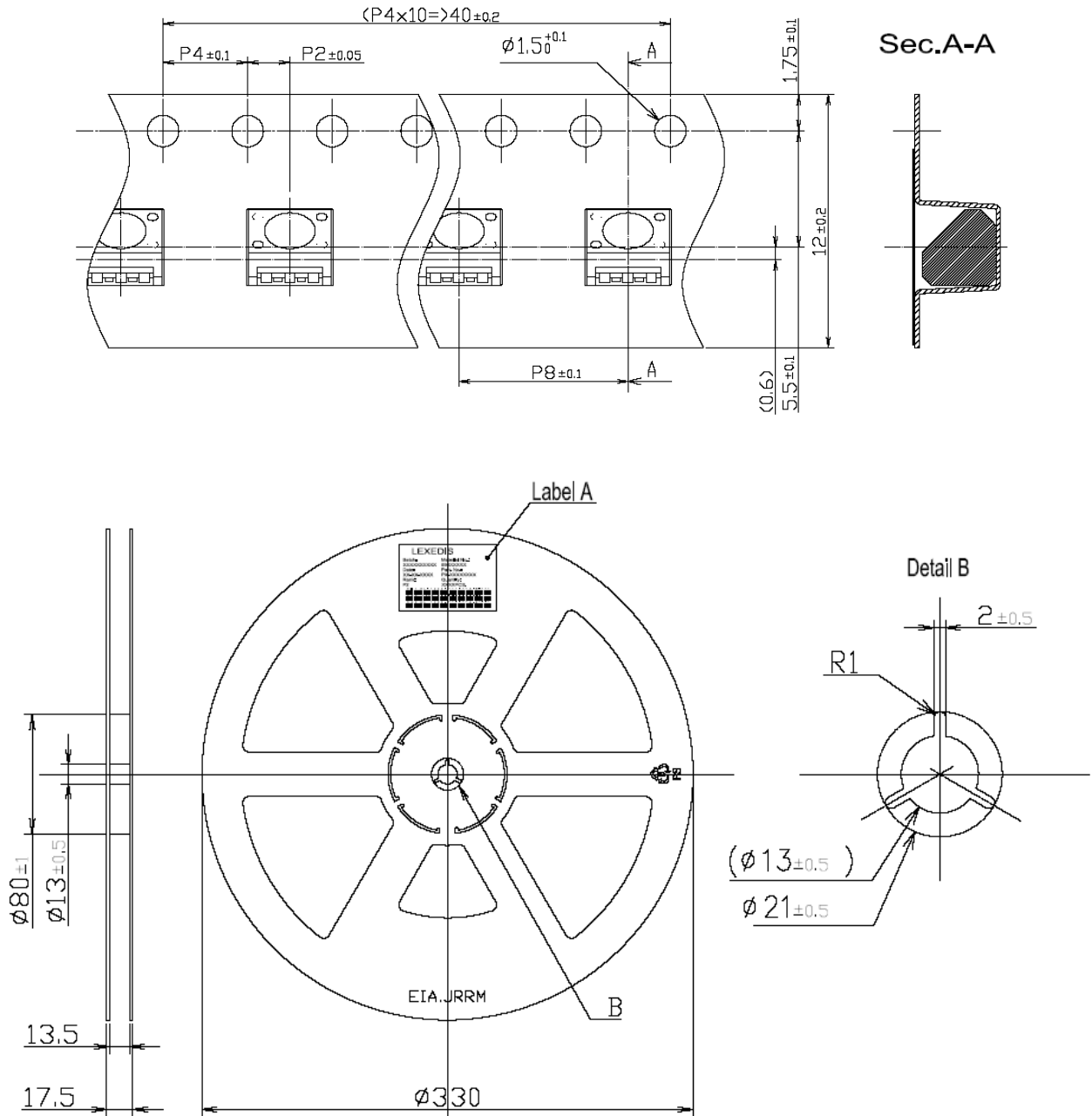

8. Labeling

The label on the packing units shows the type number, part number, quantity, date and batch number.

8.1 Label positions

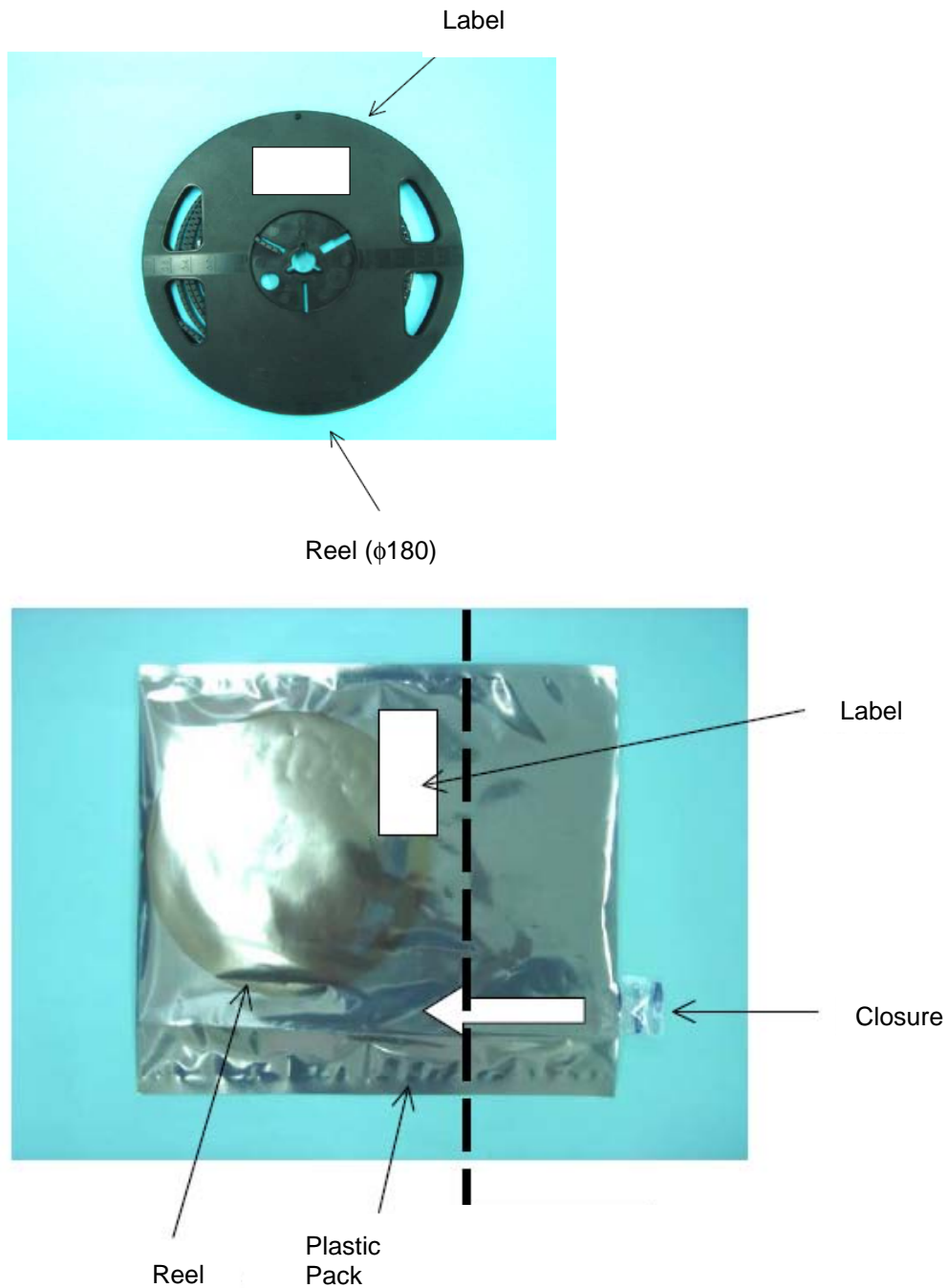



9. Precautions in Handling

[For more detailed information about Handling, Precautions, Mounting, Soldering, Cleaning, Usage and Warranty refer to our 'General Guidelines' (document nr.: LX_M&S_JE001) at our homepage].

9.1 Safety Precautions

- The LED light output is intense enough to cause injury to human eyes if viewed directly. Precautions must be taken to avoid looking directly at the LEDs with unprotected eyes [according IEC 60825-1 (EN 60825-1)].

9.2 Protection against electrostatic discharge – ESD

- LEDs are electronic components and sensitive to electrostatic discharge. Appropriate ESD protection measures must be taken when working with LED products. For example, earthed shoes or ESD wristbands have to be applied. Non-compliance with ESD protection measures may lead to damage or destruction of the product.

9.3 Precaution in driving

- Products are designed exclusively for forward current driving. Please avoid driving system with reverse voltage, which may cause migration which damages the product.

9.4 Baking

- If the moisture absorbent material (silica gel) is no longer effective or the products have exceeded the storage time, baking treatment should be performed under the following condition:
- Baking treatment : more than 12 hours at $60\pm 5^{\circ}\text{C}$.

9.5 Cleaning

- Chemical solvents or cleaning agents must not be used to clean the LED component. Mechanical stress on the LED component must be avoided. It is best to use a soft brush, damp cloth or low-pressure compressed air.

9.6 Storage

- LEDs should ideally be stored in as-delivered condition and in the original packaging. The products should be stored away from direct light in dry location.
- After opening the package:
The LEDs should be kept at 30°C or less and 70%RH or less. The LEDs should be soldered within 168 hours after opening the package. If unused LEDs remain, they should be stored in the moisture proof packages, such as sealed containers with packages of moisture absorbent material (silica gel). It is also recommended to return the LEDs to the original moisture proof bag and to reseal the moisture proof bag again.
- Please avoid rapid transitions in ambient temperature, especially in high humidity environments where condensation could occur.

10. Reliability Test Data

Item	Test Conditions	Time/Cycles	Judge Type	Defect Nr./ Sample Nr.
Operating Test	$T_a=25^{\circ}\text{C}$, $I_F=30\text{mA}$	1000 h	B	0/30
High Temperature and Humidity Operating Test	$T_a=60^{\circ}\text{C}$, RH=90%, $I_F=15\text{mA}$	1000 h	B	0/30
High Temperature Storage Test	$T_a=100^{\circ}\text{C}$, disconnected	1000 h	B	0/30
Low Temperature Storage Test	$T_a=-40^{\circ}\text{C}$, disconnected	1000 h	B	0/30
Temperature Cycle Test	$T_a=-40 / 25 / 100 / 25^{\circ}\text{C}$ $t=30 / 5 / 30 / 5$ min disconnected	100 cycles	B	0/30
Temperature / Humidity Storage Test	$T_a=60^{\circ}\text{C}$, RH=90%, disconnected	1000 h	B	0/30
Thermal Shock Test	$T_a=-40 / -- / 100^{\circ}\text{C}$ $t=1\text{min}/10\text{s}/1\text{min}$ disconnected	100 cycles	B	0/30
Moisture Resistance	$T_a=25^{\circ}\text{C} \rightarrow 65^{\circ}\text{C} \rightarrow -10^{\circ}\text{C}$, RH=90% $t=24$ h / cycle disconnected	10 cycles	B	0/30
Soldering Heat Test	$T_a=260^{\circ}\text{C}$	5 sec., twice	A	0/30
Electrostatic Discharge Test	R= 1.5K ohm / C =100pF Test voltage= $\pm 1\text{kV}$	Once	C	0/20

Criteria A for Judging the damage

Item	Symbol	Verification Criteria (admissible range)	Measuring Conditions
Forward Voltage	V_F	I.M.V. $\times 0.8 < V_F < 1.2 \times$ I.M.V.	$T_a=25^{\circ}\text{C}$, $I_F=20\text{mA}$
Reverse Current	I_R	$I_R \leq 1.2 \times$ Maximum Rating	$T_a=25^{\circ}\text{C}$, $V_R=5$ V
Luminous Intensity	I_V	I.M.V. $\times 0.7 < I_V$	$T_a=25^{\circ}\text{C}$, $I_F=20\text{mA}$

Criteria B for Judging the damage

Item	Symbol	Verification Criteria (admissible range)	Measuring Conditions
Forward Voltage	V_F	I.M.V. $\times 0.8 < V_F < 1.2 \times$ I.M.V.	$T_a=25^{\circ}\text{C}$, $I_F=20\text{mA}$
Reverse Current	V_R	$I_R \leq 1.2 \times$ Maximum Rating	$T_a=25^{\circ}\text{C}$, $V_R=5$ V
Luminous Intensity	I_V	I.M.V. $\times 0.5 < I_V$	$T_a=25^{\circ}\text{C}$, $I_F=20\text{mA}$

Criteria C for Judging the damage

Item	Symbol	Verification Criteria (admissible range)	Measuring Conditions
Forward Voltage	V_F	$V_F \geq 2.0$ V	$T_a=25^{\circ}\text{C}$, $I_F=20\mu\text{A}$

*) I.M.V.: Initial Measured Value



©2006 LEXEDIS Lighting GmbH. All rights reserved.
LEXEDIS is a joint venture between Toyoda Gosei and Tridonic.Atco.

LEXEDIS Lighting GmbH
Technologiapark 10
A-8380 Jennersdorf
Austria
Tel.nr.:+43-(0)5-9010-650-00