

# Compact Power Supply Drives TFT-LCD and LED Backlight

by Dongyan Zhou

## Introduction

The LT1942 is a highly integrated, 4-output switching regulator designed to power small to medium size TFT panels. Three of the switching regulators provide the TFT bias voltages. The fourth regulator is designed to drive backlight LEDs.

The TFT supply includes two boost converters and one negative output DC/DC converter. Since different types of panels may require different bias voltages, all three output voltages are adjustable for maximum flexibility.

The LED driver is a boost converter that has built-in precise dimming control. The user can choose to drive a single string or two strings of LEDs. A built-in ballast circuit helps to match the LED currents precisely if two strings are used.

All four regulators are synchronized to a 1MHz internal clock, allowing the use of small, low cost inductors and ceramic capacitors. Programmable soft-start capability is available for both the primary TFT supply and LED driver to control the inrush current. The LT1942 is available in a tiny 4mm × 4mm QFN package.

## Li-Ion to 4-Inch or 5-Inch TFT-LCD

Figure 1 shows a complete power supply for three TFT bias voltages ( $V_{DD}$ ,  $V_{ON}$ , and  $V_{OFF}$ ) and a white LED driver. A typical application of this design is a 4- or 5-inch amorphous silicon TFT-LCD panel powered by a single cell Li-ion input. Two boost converters are used to supply  $V_{DD}$  and  $V_{ON}$ , while the negative output converter generates  $V_{OFF}$ .

The LT1942 has built-in power sequencing to properly power up the TFT panel. When the shutdown pin is driven above 1V, the  $V_{DD}$  switcher is enabled first. After its output reaches 97% of the set value, the  $PGOOD$  pin is driven low, which enables both the  $V_{OFF}$  and  $V_{ON}$  switchers. A built-in PNP separates the  $V_{ON}$  bias supply from its boost regulator output. The PNP is not turned on until the programmable delay set by the CT pin has elapsed. This delay gives the column drivers and the digital part of the LCD panel time to get ready before the panel is turned on.

The fourth switcher in the LT1942 is a boost regulator designed to drive up to 20 LEDs (in two strings) to power the backlight. Built-in current ballast circuitry keeps the current into LED1 and LED2 actively matched, regardless of the difference in the LED voltage drops. Figure 2 demonstrates the current matching between the two LED strings. The LED regulator has a control pin (CTRL4), which provides both shutdown and dimming functions. If any LED fails open, the output of the LED regulator (D4) is clamped

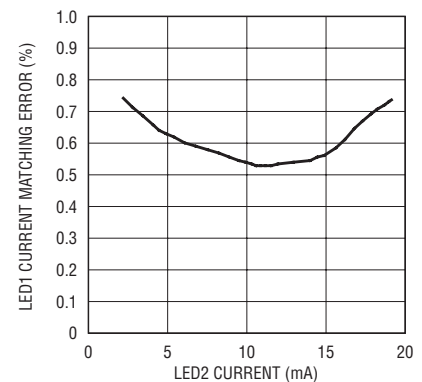

Figure 2. Typical current matching between LED1 and LED2

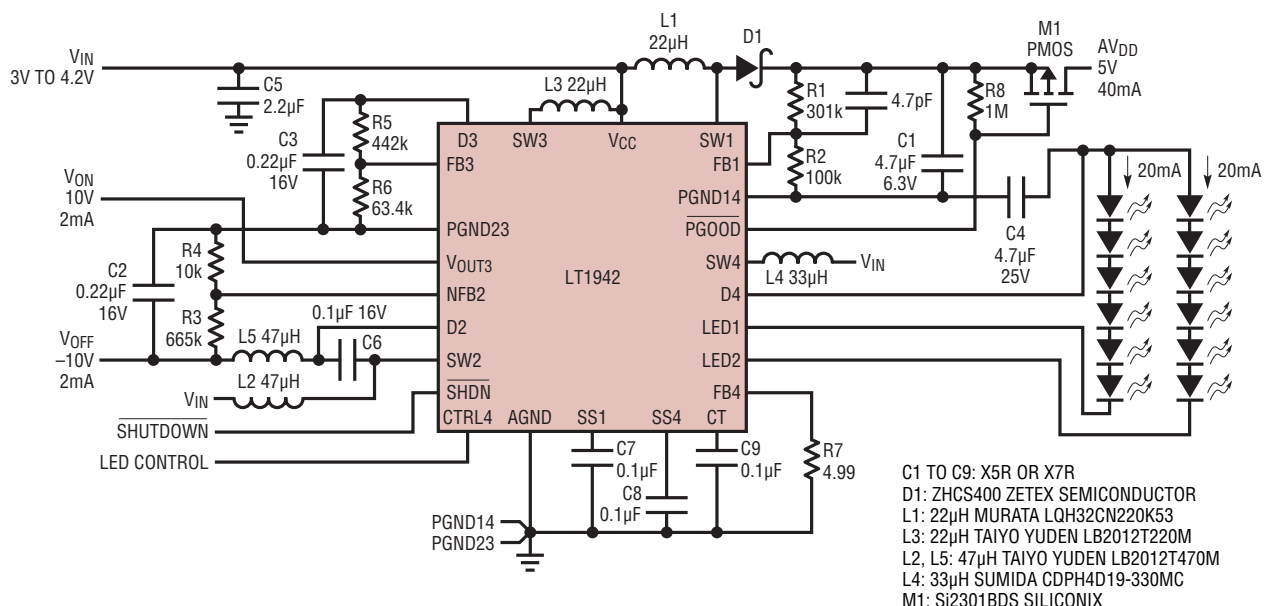

Figure 1. TFT bias voltages and LED backlight power supply from single Lithium-Ion battery input

at around 42V to protect the internal power devices.

**Layout Considerations**

Proper layout is important to achieve the best performance. Paths that carry high switching current should be kept short and wide to minimize the parasitic inductance. In the boost regulator, the switching loop includes the internal power switch, the Schottky diode (internal or external), and the

output capacitor. In the negative output regulator, the switching loop includes the internal power switch, the flying capacitor between the SW2 and D2 pins, and the internal Schottky diode.

Connect the output capacitors of the AV<sub>DD</sub> and LED switchers directly to the PGND14 pin before returning to the ground plane. Connect the output capacitor of the V<sub>ON</sub> switcher to the PGND23 pin before returning to the

ground plane. Also connect the bottom feedback resistors to the AGND pin. Connect the PGND14, PGND23 and AGND pins to the top layer ground and AGND pins to the top layer ground pad underneath the exposed copper ground on the backside of the IC. The exposed copper helps to reduce thermal resistance. Multiple vias into ground layers can be placed on the ground pad directly underneath the part to conduct the heat away from the part. **LT**

*LTC3426, continued from page 22*

least 750mA from a V<sub>IN</sub> as low as 3V. When fully charged to 4.2V, over 1A can be supplied. The photograph of a demonstration board in Figure 5 shows just how small the board area is for this application, 10mm × 12mm. Tiny ceramic bypass capacitors and surface mount inductors keep the design small.

Figure 6 shows efficiency exceeding 90% and remaining greater than 85% over a load range from 10mA to 900mA with a fully charged battery.

**Component Selection**

The LTC3426 requires just a few external components to accommodate various V<sub>IN</sub> and V<sub>OUT</sub> combinations. Selecting the proper inductor is important to optimize converter performance and efficiency. An inductor with low DCR increases efficiency and reduces self-heating. Since the inductor conducts the DC output current plus half the peak-to-peak switching current, select an inductor with a minimum DC rating of 2A. To minimize V<sub>OUT</sub> ripple, use low ESR X5R ceramic capacitors. The average Schottky diode forward current is equal to the DC output current therefore the diode average

current should be greater than 1A. A low forward voltage Schottky diode reduces power loss in the converter circuit.

**Conclusion**

The addition of the LTC3426 to Linear Technology's high performance boost converter family allows the designer to deliver high current levels with minimal board space. An on chip switch and internal loop compensation reduces component count to provide an inexpensive solution for spot regulation applications. **LT**

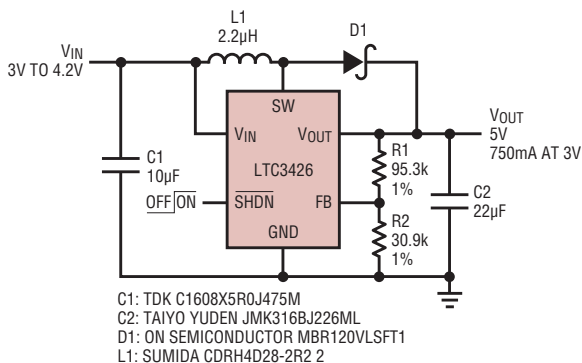

**Figure 4. Compact application circuit for V<sub>OUT</sub> at 5V**

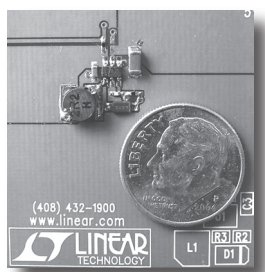

**Figure 5. Photograph of demo board of circuit in Figure 4—board area is 10mm × 12mm**

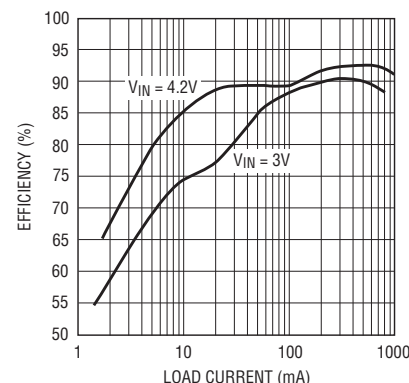

**Figure 6. Up to 92% efficiency in Lithium-Ion battery to 5V output applications**

*LTC4302, continued from page 26*

further eases the burden of heavy capacitive loads by providing strong pull-up currents during rising edges to reduce the rise time. Thanks to these two features, the LTC4302 enables the implementation of much larger 2-wire bus systems than are possible with a simple unbuffered multiplexer. **LT**

**For further information on any of the devices mentioned in this issue of Linear Technology, use the reader service card or call the LTC literature service number:**

**1-800-4-LINEAR**

**Ask for the pertinent data sheets and Application Notes.**

*Impedance Analyzer, continued from page 30*

assume that either the inductance is well damped, or it is shunted by large value capacitances. **LT**

**Notes**

1. This subject is treated in some detail in the LTC1647 data sheet, Figures 9, 10, and 11 inclusive.
2. An hp 5210A Frequency Meter or any common counter gives adequate accuracy for most measurements.