

Linear Technology Chronicle

High Performance Analog Solutions

VOL 17 NO. 2

FOCUS...

DC/DC μ Module Power Supply Solutions

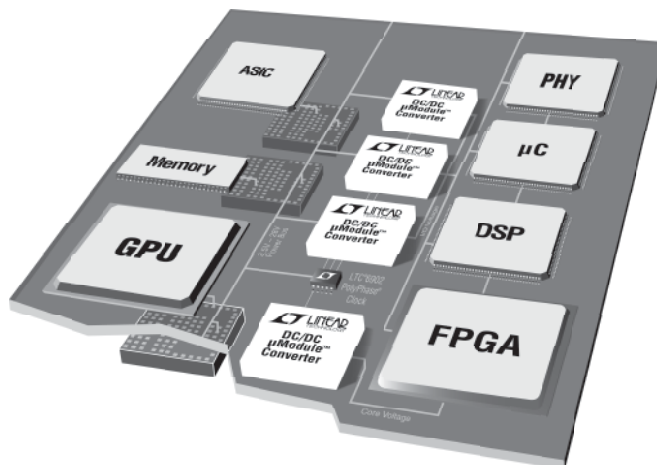

Inside This Issue

- **Ultralow Noise Step-Downs**
- **Dual Output Step-Downs**
- **High Current Step-Downs**
- **Low Input Voltage Step-Downs**
- **High Input Voltage Step-Downs**
- **Military Plastic Step-Downs**
- **Buck-Boosts**
- **LED Driver**

A switching mode power supply design can be a challenge even for an expert analog designer. Besides calculating values and selecting components, there are also details to be considered such as the layout, ground planes, PCB vias, soldering and thermal management. Furthermore, densely populated embedded systems boards using the latest generation FPGAs, DSPs, microcontrollers and memory modules have additional quality, board dimensions and high current requirements that are not easily met by traditional point-of-load solutions.

To alleviate these challenges and time to market pressures, Linear Technology has developed eight DC/DC μ Module™ families designed to address specific power requirements. These DC/DC μ Module regulators include switching controllers, power FETs, inductors (except for buck-boost) and additional components, all in single low profile packages. The only external components required are bulk input and output capacitors and a resistor to set the output voltage.

Moreover, the electrical and thermal performance of each device is accurately controlled because Linear Technology designs, tests and fabricates 100% of the content silicon. The result is a high performance DC/DC system with a very low thermal impedance land grid array (LGA) package capable of delivering power with maximum heat dissipation. The LGA package is suitable for automated assembly by standard surface mount equipment.

As of this publication, Linear Technology's DC/DC μ Module family has undergone 8,595,540 hours of power cycling from 50°C to 100°C with zero failures. For more detailed information, please refer to www.linear.com/micromodule.

Ultralow Noise Step-Down μ Module Regulators

To power the high speed serial or parallel data interfaces in the latest generation of FPGAs, DSPs and microcontrollers, Linear Technology offers an exceptional family of ultralow noise μ Module regulators. The new generation of power-sensitive systems have very strict noise and electromagnetic interference (EMI) requirements for high speed (Gbps) I/O, RF and audio circuits that operate in confined environments.

The LTM[®]4606 and LTM4612 are ultralow noise, high voltage DC/DC μ Module regulators. An onboard

input filter and noise cancellation circuits achieve ultralow noise operation, effectively reducing EMI. Included in the package are the switching controller, power FETs, inductor and supporting components. Only a resistor, a bulk input and output capacitor are needed to complete the design.

High switching frequency and an adaptive on-time current mode architecture enable a very fast transient response to line and load changes without sacrificing stability. The device supports output voltage tracking and output voltage

margin. Furthermore, the LTM4606 and LTM4612 can be synchronized to an external clock to reduce undesirable frequency harmonics and allow for PolyPhase[®] operation.

The LTM4606 and LTM4612 are available in 15mm x 15mm x 2.8mm LGA packages.

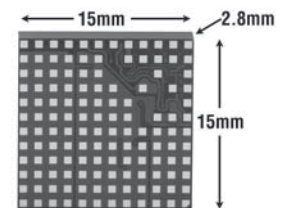

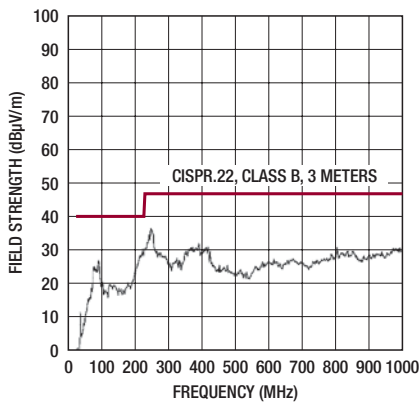

**LTM4606 Radiated Emission Scan
with 12V_{IN} to 2.5V_{OUT} at 6A**

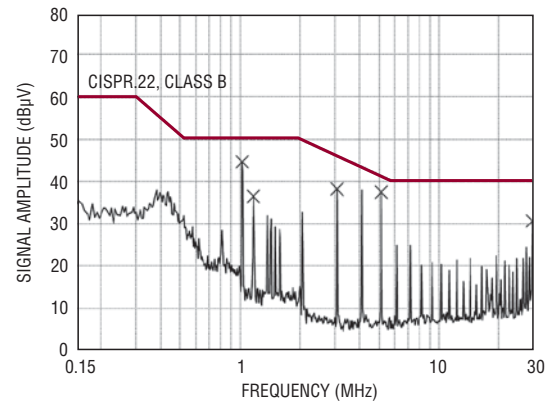

**LTM4612 Conducted Emission Scan
with 24V_{IN} to 12V_{OUT} at 5A**



Selected Ultralow Noise Step-Down DC/DC μ Module Regulators

| Part Number | V _{IN} Min | V _{IN} Max | V _{OUT} Min | V _{OUT} Max | I _{OUT} | PLL | Track/Margin | Package |
|-------------|---------------------|---------------------|----------------------|----------------------|------------------|---|---|-------------------------|
| LTM4606 | 4.5V | 28V | 0.6V | 5V | 6A |  |  | 15mm x 15mm x 2.8mm LGA |
| LTM4612 | | 36V | 3.3V | 15V | 5A | | | |

Dual Output Step-Down μ Module Regulators

Linear Technology's new family of dual output μ Module regulators includes two independent and complete DC/DC switching regulator circuits. By housing the inductors, capacitors, compensation components and DC/DC controllers in a single surface mount package, the LTM4614 and LTM4616 reduce the bill of materials of an otherwise complex dual regulator design from 32 components to one. The small and thin plastic LGA (land grid array) package features extremely low thermal impedance, allowing very efficient and quick heat removal from the substrate and top of the package to the ambient. This is especially important in densely populated circuit boards, offering a simple solution for powering both core and I/O supplies for FPGAs and ASICs.

A high switching frequency, current mode architecture enables a very fast transient response to line and load changes without sacrificing stability. Efficiency is typically up to 95%. The two regulators on each device operate from separate input voltages,

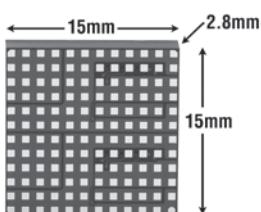

ranging from 2.375V to 5.5V, and the output voltages are set by a single resistor for each output. Outputs may be paralleled for higher current. Fault protection features include overvoltage protection, overcurrent (short circuit) protection, thermal shutdown and soft-start.

The LTM4616 is a dual multiphase switch mode DC/DC power regulator system that can regulate either two voltages ranging from 0.6V to 5V at up to 8A each, or one output voltage at up to 16A by sharing current from each output. The LTM4616 can also operate from either of two different input supplies or from one input supply by tying the input pins together.

For output loads that demand more than 8A of current, the outputs of two or more LTM4616s can be cascaded to run out of phase to provide more output current without increasing input and output voltage ripples.

Additional highlights of LTM4616 include:

- Onboard frequency synchronization
- Power good tracking and margining
- Spread spectrum frequency modulation
- Selectable Burst Mode® operation
- Available in 15mm x 15mm x 2.8mm LGA package

Dual Output Parallel DC/DC μ Module Regulator, 2.5V at 16A Design

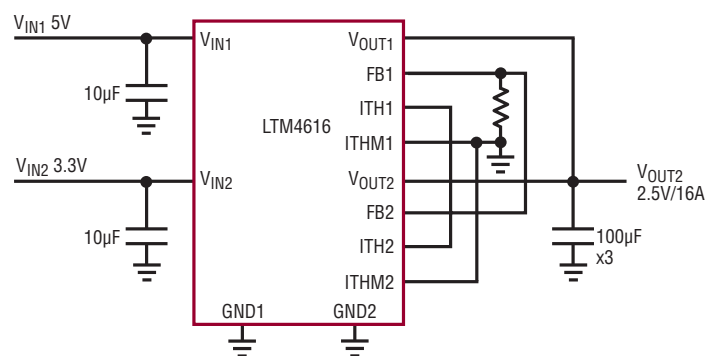

Selected Dual Output Step-Down DC/DC μ Module Regulators

| Part Number | V_{IN} Min | V_{IN} Max | V_{OUT} Min | V_{OUT} Max | I_{OUT} | PLL | Track/Margin | Current Share | Package |
|-------------|--------------|--------------|---------------|---------------|-----------|-----|--------------|---------------|-------------------------|
| LTM4616 | 2.4V | 5.5V | 0.8V | 5V | 8A, 8A | | | Up to 2 | 15mm x 15mm x 2.8mm LGA |
| LTM4614 | | | | | 4A, 4A | | | | |

High Current Step-Down μ Module Regulators

The LTM4601AHV is a 12A μ Module regulator featuring phase-lock loop and output tracking. It includes a synchronous step-down regulator with built-in inductor, supporting power components and compensation circuitry. This simplifies power supply design and construction, requiring only input and output bulk capacitors and a resistor to set the output voltage.

The LTM4601A LGA package is designed with redundant mounting pads to enhance solder-joint strength

for extended temperature cycling endurance. Additionally, the LTM4601AHV can be synchronized with an external clock for reducing undesirable frequency harmonics, allowing PolyPhase operation for high load currents. An onboard differential remote sense amplifier can be used to accurately regulate an output voltage independent of load current. Additionally, the LTM4601AHV is self-protected against output overvoltage and short circuit conditions.

Additional highlights of LTM4601AHV include:

- 4.5V to 28V input voltage range
- 12A DC continuous output current, parallel up 48A
- 0.6V to 5V output voltage range
- Up to 92% efficiency
- Available in 15mm x 15mm x 2.8mm LGA package

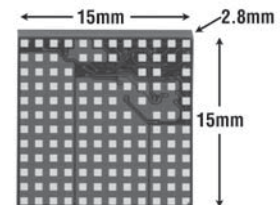
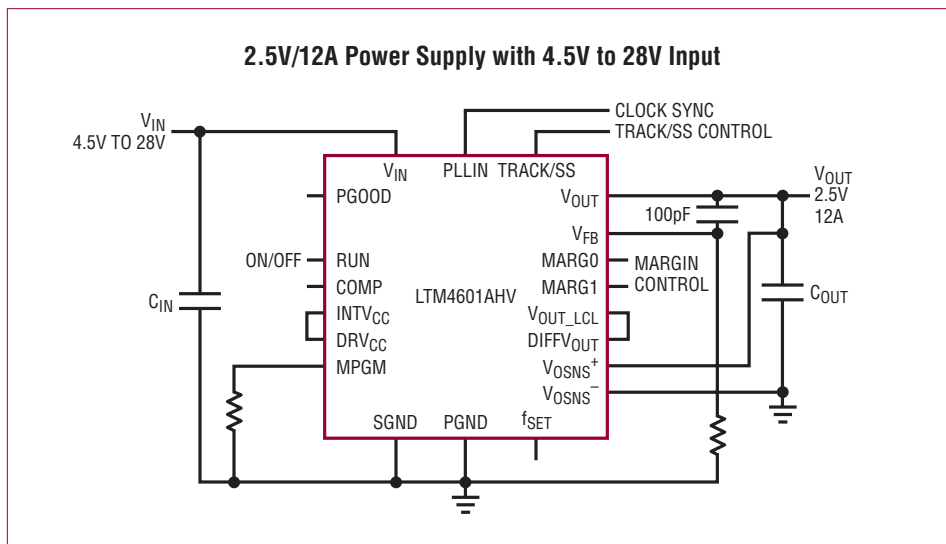

Selected High Current Step-Down DC/DC μ Module Regulators

| Part Number | V_{IN} Min | V_{IN} Max | V_{OUT} Min | V_{OUT} Max | I_{OUT} | PLL | Track/Margin | Remote Sense | Current Share | Package | |
|-------------|--------------|--------------|---------------|---------------|-----------|-----|--------------|--------------|---------------|-------------------------|---------|
| LTM4601A | 4.5V | 20V | 0.6V | 5V | 12A | ☑ | ☑ | ☑ | Up to 4 | 15mm x 15mm x 2.8mm LGA | |
| LTM4601AHV | | 28V | | | | | | | | | |
| LTM4601 | | 20V | | | | | | | | | |
| LTM4601HV | | 28V | | | | | | | | | |
| LTM4600 | | 20V | | | 10A | ☐ | ☐ | ☐ | ☐ | | Up to 2 |
| LTM4600HV | | 28V | | | | | | | | | |
| LTM4603 | | 20V | | | | | | | | | |
| LTM4603HV | | 28V | | | 6A | ☑ | ☑ | ☑ | ☑ | | Up to 4 |
| LTM4602 | | 20V | | | | | | | | | |
| LTM4602HV | | 28V | | | | | | | | | |
| | | | | | | | | | Up to 2 | | |

Low Input Voltage Step-Down μ Module Regulators

The LTM4604 is an integrated 4A power supply with an onboard controller, power switches, inductor and bypass capacitors. This compact and high reliability DC/DC point-of-load solution is targeted for applications that need to step-down input supply rails such as 5V, 3.3V, 2.5V or Li-Ion batteries with precise regulation and excellent thermal performance.

With a profile of only 2.3mm, the LTM4604 can be used as an ultra-thin point-of-load solution for such systems as RAID, PCI or PCI Express. Additionally, the low profile package enables mounting on the back side of PC boards.

The device features current mode architecture for fast transient response, short-circuit protection and excellent line and load regulation. In addition,

it offers output voltage tracking for controlled ramp-up/ramp-down and supply sequencing.

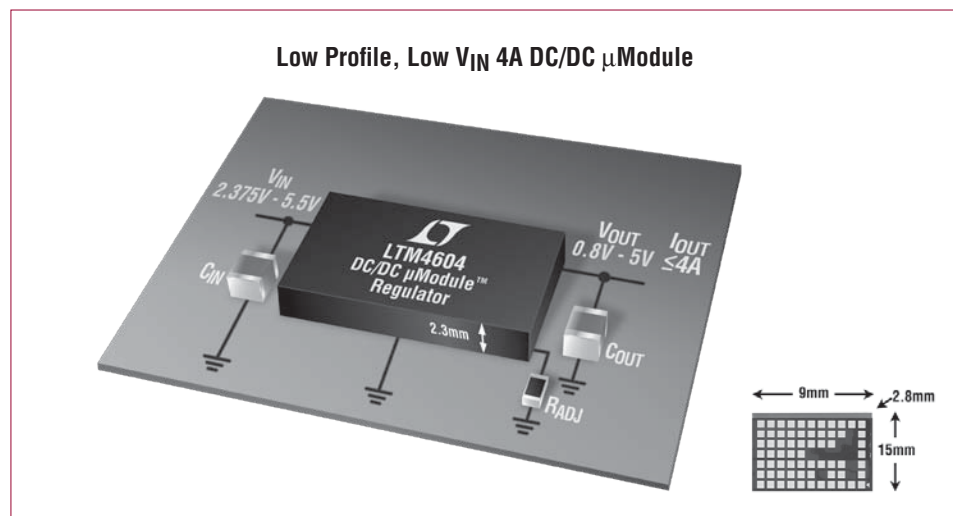

Selected Low Input Voltage Step-Down DC/DC μ Module Regulators

| Part Number | V_{IN} Min | V_{IN} Max | V_{OUT} Min | V_{OUT} Max | I_{OUT} | PLL | Track/Margin | Current Share | Package |
|-------------|--------------|--------------|---------------|---------------|-----------|-----|--------------|---------------|------------------------|
| LTM4608 | 2.4V | 5.5V | 0.6V | 5V | 8A | | | Up to 3 | 9mm x 15mm x 2.8mm LGA |
| LTM4604 | | | 0.8V | | 4A | | | | Up to 2 |

High Input Voltage Step-Down DC/DC μ Module Regulators

The LTM8020 is a compact and low profile (6.25mm x 6.25mm x 2.32mm) DC/DC step-down power supply with a wide 4V to 36V input voltage range that can regulate output voltages between 1.25V and 5V at 200mA. With onboard inductor, power switches and other circuitry, this device operates cooler, is smaller

than a linear regulator and is simpler than a discrete switchmode DC/DC regulator. At light loads, Burst Mode operation keeps quiescent current to 50 μ A.

Additionally, the low profile package enables utilization of unused space on the back side of PC boards.

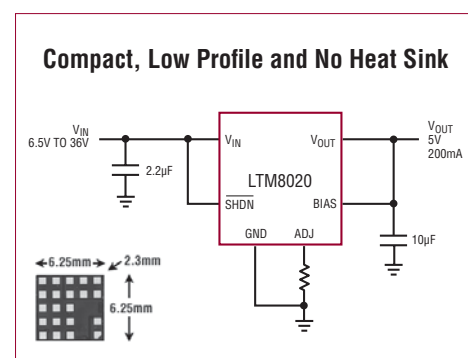

Selected High Input Voltage Step-Down DC/DC μ Module Regulators

| Part Number | V_{IN} Min | V_{IN} Max | V_{OUT} Min | V_{OUT} Max | I_{OUT} | Current Share | Package |
|-------------|--------------|--------------|---------------|-----------------------------|-----------|---------------|------------------------------|
| LTM8023 | 3.6V | 36V | 0.8V | 10V | 2A | Up to 2 | 11.25mm x 9mm x 2.8mm LGA |
| LTM8022 | | | | | 1A | | |
| LTM8021 | | | | 5V | 0.5A | | 11.25mm x 6.25mm x 2.8mm LGA |
| LTM8020 | 4V | 1.25V | 0.2A | 6.25mm x 6.25mm x 2.3mm LGA | | | |

Military Plastic Step-Down DC/DC μ Module Regulators

DC/DC μ Module regulator's LGA package has been qualified for high power DC/DC designs and exhibits lower thermal impedance when compared to a similar size ball grid array (BGA) package. The gold-pad finish on the LGA package allows soldering with Pb or Pb-Free solder paste.

Linear Technology's MP-grade μ Module regulators are guaranteed to meet data sheet specifications over the full -55°C to 125°C temperature range. All grades are 100% electrically tested at room temperature to guard banded data sheet test limits. Additionally, MP-grade devices are 100% electrically tested at 125°C and -55°C to guard banded data sheet test limits. All grades of product are tested to accept zero failure criteria.

Comprised entirely of Linear Technology silicon, the DC/DC μ Module regulator system also brings component-level reliability and performance to high reliability applications. Encapsulated packaging protects the circuit components against mechanical, chemical and ambient factors, thus improving the reliability of the solution.

If you are not a rugged military or aerospace customer, you may still benefit from MP-grade's extended temperature range performance

for demanding automotive, industrial or communications applications.

For more information on Linear's military plastic products and flow, please refer to www.linear.com/mpgrade.

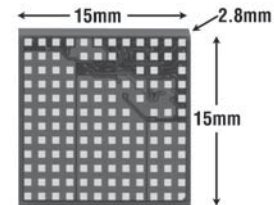

Military Plastic, -55°C to 125°C Tested 12A DC/DC μ Module

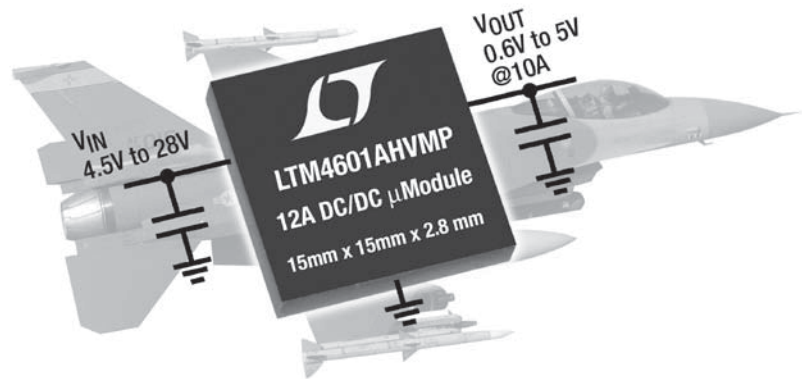

Selected Military Plastic Step-Down DC/DC μ Module Regulators

| Part Number | V_{IN} Min | V_{IN} Max | V_{OUT} Min | V_{OUT} Max | I_{OUT} | PLL | Track/Margin | Remote Sense | Current Share | Package |
|--------------|--------------|--------------|---------------|---------------|-----------|-----|--------------|--------------|---------------|-------------------------|
| LTM4601AHVMP | 4.5V | 28V | 0.6V | 5V | 12A | | | | Up to 4 | 15mm x 15mm x 2.8mm LGA |
| LTM4600HVMP | | | | | 10A | | | Up to 2 | | |
| LTM4606MP | | | | | 6A | | | | | |
| LTM4612MP | | | | | 15V | 5A | | | | |
| LTM4608AMP | 2.4V | 5.5V | | 5V | 8A | | | | Up to 3 | 9mm x 15mm x 2.8mm LGA |

Buck-Boost DC/DC μ Module Regulators

A challenging task for a power supply designer is producing a high power density supply where the output voltage is within the input voltage range. Conventional buck-boost converter topologies, such as SEPIC or boost, followed by buck, are usually complex, require bulky magnetics, run at low efficiency and place high electrical and thermal stresses on devices. Linear Technology's 4-switch buck-boost regulators improve efficiency, save space

and provide a smooth transition between each mode of operation.

The LTM4605 and LTM4607 μ Module regulators can solve these buck-boost challenges by reducing the component selection to an inductor, a sense resistor and bulk input and output capacitors.

The high switching frequency and current mode architecture enable a very fast transient response to line and load changes. Efficiency is typically up to 92% in boost

mode and 98% in buck mode. Fault protection features include overvoltage and foldback current protection.

Frequency synchronization via a phase-locked loop to an external clock is also available to reduce undesirable frequency harmonics. If more output current is needed, two or more LTM4605s or LTM4607s can be connected in parallel.

Both devices are available in a surface mount 15mm \times 15mm \times 2.8mm LGA package.

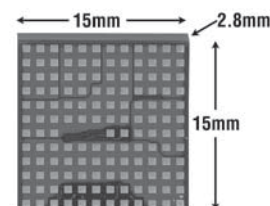
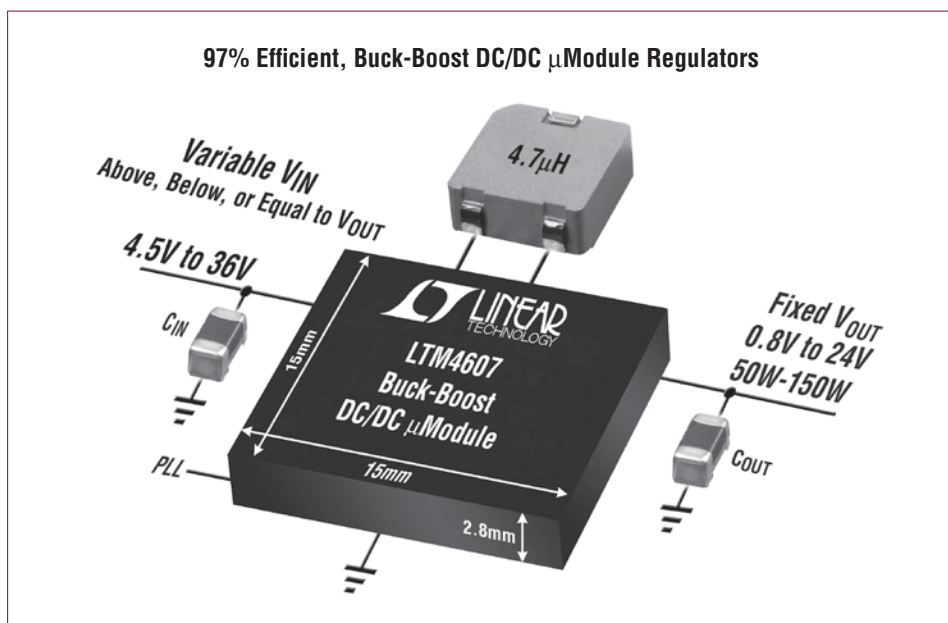

Selected Buck-Boost DC/DC μ Module Regulators

| Part Number | V_{IN} Min | V_{IN} Max | V_{OUT} Min | V_{OUT} Max | I_{OUT} | PLL | Package |
|-------------|--------------|--------------|---------------|---------------|-----------|---|-------------------------|
| LTM4607 | 4.5V | 36V | 0.8V | 25V | 5A to 10A |  | 15mm x 15mm x 2.8mm LGA |
| LTM4605 | | 20V | | 16V | | | |

Step-Down μ Module LED Driver

The LTM8040 is a fixed frequency, 1A step-down DC/DC μ Module driver designed to operate as a constant current source. Internal circuitry monitors the output current to provide accurate current regulation, ideal for driving high current LEDs. High output current accuracy is maintained over a wide current range, from 35mA to 1A, allowing a wide dimming range. Unique PWM circuitry allows a dimming range of 400:1, avoiding the

color shift normally associated with LED current dimming.

With its wide input range of 4V to 36V, the LTM8040 accepts a broad array of power sources, from 4-cell batteries and 5V logic rails to unregulated wall transformers, lead acid batteries and distributed power supplies. The LTM8040 is also equipped with thermal protection that reduces the output LED current

if the internal operating temperature is too high.

Highlights of LTM8040 include:

- Programmable LED current
- Open LED and short-circuit protection
- Available in 15mm x 9mm x 2.82mm LGA package

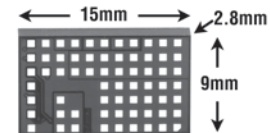
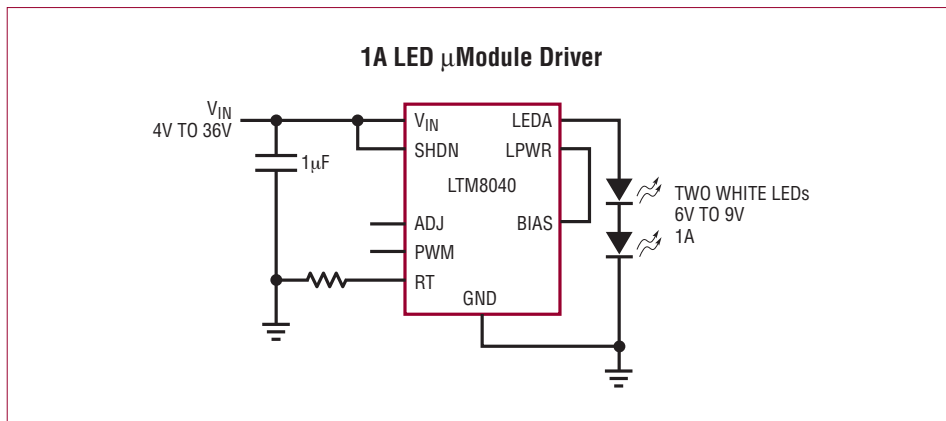

U.S. Sales Offices

GREATER BAY AREA

Bay Area
(408) 428-2050
Sacramento
(916) 787-5210

PACIFIC NORTHWEST

Denver
(303) 926-0002
Portland
(503) 520-9930
Salt Lake City
(801) 731-8008
Seattle
(425) 748-5010

SOUTHWEST AREA

Los Angeles
(818) 703-0835

Orange County
(949) 453-4650

San Diego
(858) 638-7131

CENTRAL AREA

Chicago
(847) 925-0860
Cleveland
(440) 239-0817
Columbus
(614) 488-4466
Detroit
(734) 779-1657
Indiana
(317) 581-9055
Kansas
(913) 829-8844

Minneapolis
(952) 903-0605

Wisconsin
(262) 859-1900

NORTHEAST AREA

Boston
(978) 656-4750
Connecticut
(860) 228-4104
Philadelphia
(215) 638-9667
SOUTHEAST AREA
Atlanta
(770) 888-8137
Austin
(512) 795-8000

Dallas
(972) 733-3071

Fort Lauderdale
(954) 473-1212

Houston
(713) 463-5001

Huntsville
(256) 881-9850

Orlando
(407) 688-7616

Raleigh
(919) 677-0066

Tampa
(813) 634-9434

North American Distributors

LINEAR EXPRESS (866) 546-3271
ARROW (800) 777-2776
DIGI-KEY (800) 344-4539
NU HORIZONS (888) 747-6846