

Dual Step-Up Converter Drives White LEDs with 1000:1 PWM Dimming

by Keith Szolusha

Introduction

Notebook computers, large-screen handheld PDAs, dashboard displays, and automotive and avionic in-cabin entertainment LCD panels are illuminated with strings of high power white LEDs. White LEDs are the preferred over other backlight technologies because they provide true white light at a high enough intensity for daylight viewing, and enough dimming capability for nighttime use. LEDs also offer relatively long life spans and a lack of hazardous materials. LED strings lining the edges of these LCD panels

provide uniform brightness when driven with a constant current.

The maximum switch voltage of an LED driver limits the number of LEDs that it can drive in series. It may seem that paralleling LEDs is a good way to increase the capacity of a driver IC, but parallel LEDs must be well-matched in forward voltage; otherwise un-matched LED strings cause uneven currents and thus uneven brightness. LEDs can be specially sorted (binned) for matching characteristics, but this increases cost.

A better solution is a dual channel LED driver to drive two strings of LEDs. This saves the space and cost of duplicating components, such as the driver IC and input capacitors. Each string is driven with the same regulated constant current, thus providing uniform brightness.

One IC that has these features is the LT3486 dual LED string driver, which has two 1.3A channels with high PWM dimming capability in a small 5mm × 3mm DFN package. Since both channels' power switches are included in the IC, the circuit is simple and small.

Dual LED String Step-Up Driver

The LT3486 is a dual step-up LED driver. Each channel has an efficient, low side 1.3A npn power switch with low $V_{CE(sat)}$ of 300mV (at 750mA switch current). The IC is designed to drive a string of LEDs from a wide input voltage range. Each LED string total voltage can be as high as 38V in a typical application, but may be limited to 34V if the overvoltage protection (OVP) pin is used to protect the switch when the LED string is open.

Figure 1 demonstrates the LT3486 as a dual LED string step-up converter driving a total of 16–20 white LEDs at 100mA from a 4V–16V input voltage range source. The total voltage of the LEDs cannot exceed 34V. The circuit is kept small and simple with the single ceramic input capacitor and two small ceramic output capacitors. With a high 800kHz switching frequency, the inductors and capacitors can be small in size while the efficiency of the circuit remains high, as shown in Figure 2. As PWM duty cycle is decreased from 100%, the circuit efficiency drops slightly, but remains high during the PWM on-time. Not only is the operating efficiency high, but the converter shutdown current

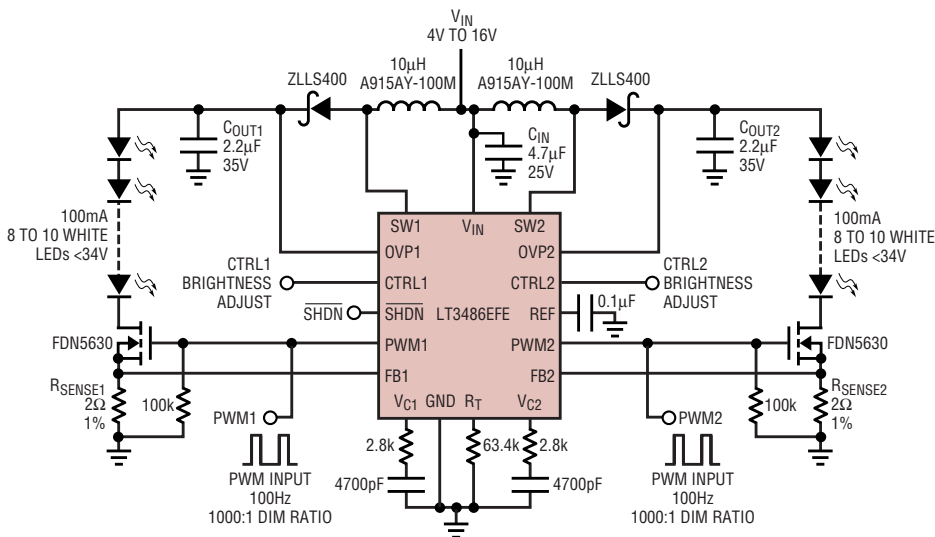

Figure 1. LED driver uses 4V–16V input to drive two strings of eight-to-ten 100mA LEDs (less than 34V total in string) with 1000:1 PWM dimming

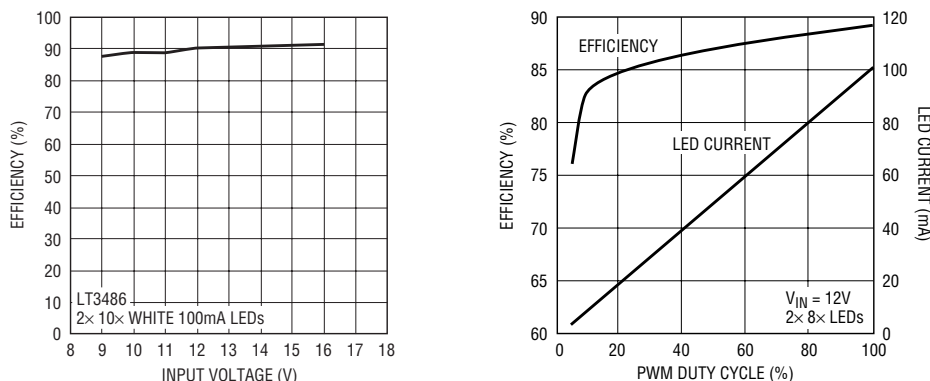

Figure 2. Efficiency of the circuit in Figure 1 and efficiency as a function of PWM duty cycle

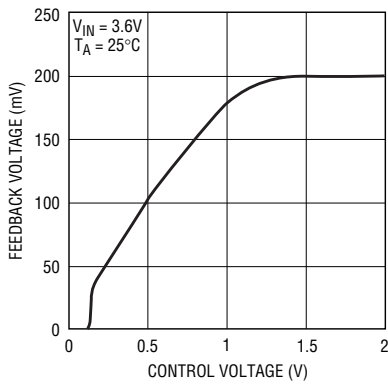

Figure 3. FB pin voltage vs CTRL pin voltage

consumption is less than 1 μ A (typically 100nA), merely sipping from the battery when the IC is off.

1000:1 PWM Dimming and 10:1 Brightness Control

As shown in Figure 1, LED brightness can be controlled on the LT3486 with an analog voltage input to the CTRL pin or a digital PWM signal to the gates of the PWM dimming MOSFET and the PWM pin. Analog brightness control reduces the LED current from 100mA to a lower value by reducing the internal sense resistor voltage. Although this is a simple way to decrease the brightness of the LED, the accuracy of the LED current control is reduced and the chromaticity of the LED changes at lower currents. The graph in Figure 3 displays the LT3486 typical FB pin voltage dropping as a

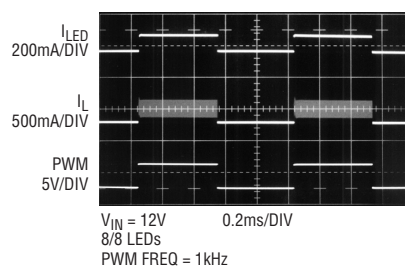

Figure 4. PWM dimming waveforms

function of CTRL pin voltage. The low 200mV FB pin (and current sense voltage) accuracy is typically 3% at full current with the CTRL pin pulled high (above 1.5V) but as the CTRL pin voltage is lowered to 150mV, the FB pin voltage is also reduced to about 40mV. Below this 5:1 dimming ratio, the LEDs are turned off as the CTRL pin voltage is pulled below 75mV.

Another method of reducing the brightness of the LEDs is digital PWM dimming. The PWM MOSFET in series with the LEDs creates the waveform shown in Figure 4 when the string of LEDs is PWM'd at 100mA constant current. During PWM on-time, the current is a well-regulated 100mA. During PWM off-time, the current is zero. Because the current is either 100mA or zero, the LED color is preserved as if the LED were driven by a constant 100mA current. Dimming is simply a function of the average, instead of instantaneous, current. The advanced PWM function in the LT3486

is particularly fast in returning the LED to its programmed LED current. Its short minimum dimming on-time (10 μ s on-time) allows a 1000:1 digital PWM dimming ratio with 100Hz PWM frequency—fast enough to avoid visible flicker. For instance, a combination of two LT3486s driving four LED strings (R-G-G-B) in a top-end display provides 1000:1 dimming while maintaining the true-color of the display even during very dim nighttime operation.

When a PWM signal is used for brightness control, but less than a 5:1 dimming range is needed and the chromaticity of the LEDs is not especially important, the PWM signal can be fed into an RC filter such as the one in Figure 6. This turns the PWM input into an analog CTRL pin voltage controlling the LED current directly, eliminating the need for the PWM dimming MOSFETs. The 5V, 16-LED converter in Figure 5 can deliver up to a 5:1 analog dimming range at the CTRL pins with such a filter without the need for the two additional PWM dimming MOSFETs. In this case, the LT3486 PWM pins are tied high to the 1.25V REF pin.

Doubler Delivers Greater than 34V to LED Strings

GPS navigation and in-cabin entertainment displays are increasingly popular in mainstream consumer vehicles. The advantage of using two LED drivers each with 8-LED strings, instead of a single 16-LED string, is that the maximum switch voltage remains that of a single 8-LED string (less than 34V total string voltage at 100mA). Even so, LCD panel screen sizes are pushing beyond the standard 6" and 7", requiring more LEDs and string voltages above 34V.

The circuit in Figure 7 uses a charge pump voltage doubler to drive two strings of LEDs to voltages as high

continued on page 44

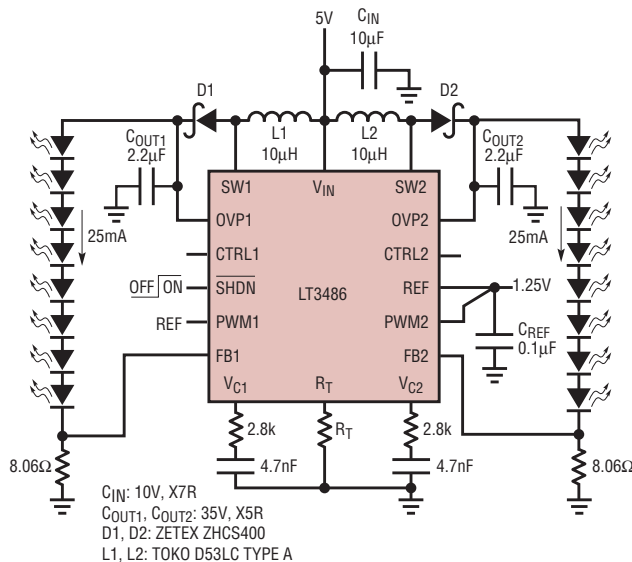

Figure 5. LED driver uses 5V input to drive two strings of eight 25mA LEDs (less than 34V total in either string) with 5:1 brightness control

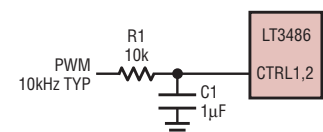

Figure 6. Achieving 5:1 brightness control with a filtered PWM signal

recharge cycle. Figure 4 shows the efficiency of LTC3240-3.3 as a function of input voltage.

In step-up (charge pump) mode, the LTC3240 uses a unique architecture to optimize the charge transferred to the output in each clock cycle, thus minimizing the output ripple. The part only needs a 4.7µF, 0603 size ceramic capacitor to obtain a 32mV maximum

ripple voltage (<1% for 3.3V output) at 150mA (See Figure 5).

To extend battery life at light loads, in charge pump mode, the part operates in high efficiency Burst Mode operation. In this case, the LTC3240 delivers a minimum amount of charge for a few cycles, and then enters a low current state until the output drops low enough to require another burst of charge.

Conclusion

The LTC3240 step-up/step-down charge pump DC/DC converter provides fixed regulated output voltage with currents up to 150mA from a wide input voltage range in a small 6-lead 2mm x 2mm DFN package. It is ideally suited for efficient DC/DC conversion in space-constrained applications such as battery-powered handheld electronics. **LT**

LT3486, continued from page 11

as 70V while both providing both overvoltage protection *and* remaining below the 42V maximum switch voltage. The charge pump Schottky diodes and capacitors double the effective output voltage for a given duty cycle while the LT3486 LED driver continues to regulate the 100mA constant LED current. The LEDs in Figure 7 have higher forward voltage than those in Figure 1 at 100mA,

resulting in a total string voltage as high as 40V. If more LEDs are needed, the string voltage can be stacked up to 70V before hitting the overvoltage protection level, but the peak switch current limit cannot be exceeded. As the string voltage and LED current goes up, the minimum input voltage also rises. Figure 8 shows the typical peak switch current limit dropping as duty cycle increases. In addition to

the peak inductor current, the voltage doubler also adds additional charge pump capacitor current.

Conclusion

The LT3486 is a dual 1.3A LED string driver with 1000:1 PWM dimming capability. Its 3% LED current accuracy, low sense voltage, low shutdown current, overvoltage protection and wide input voltage range make it ideal for high power LCD panels in a variety of applications including automotive displays and notebook computers. The simple 5:1 analog dimming ratio and more precise 1000:1 PWM dimming ratio provide the displays with enough brightness control for daylight and nighttime use while retaining their color characteristics across brightness levels. **LT**

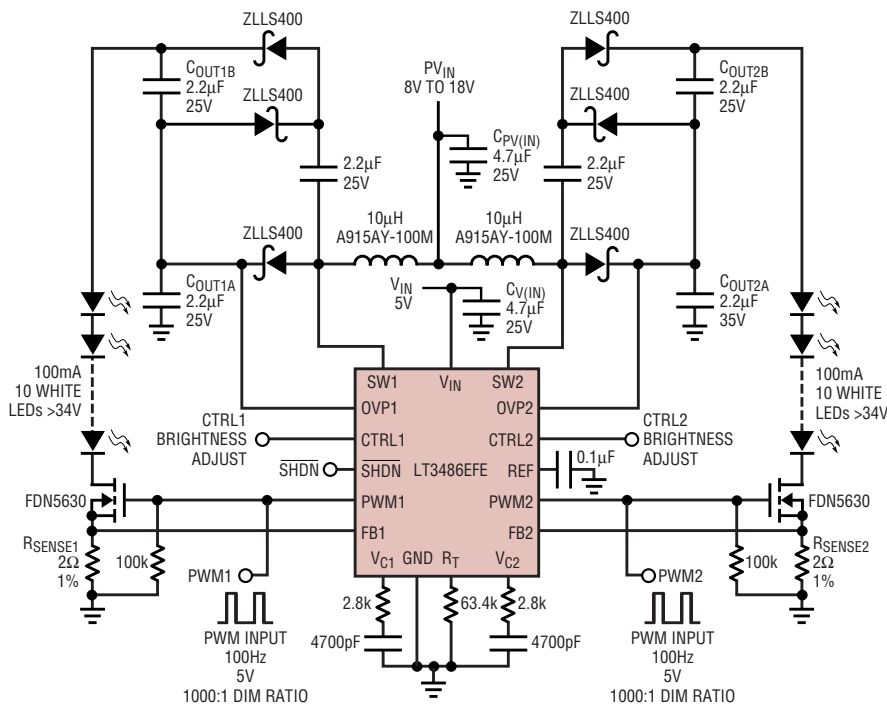

Figure 7. LED driver uses 8V–18V input to drive two strings of ten 100mA LEDs (40V max per string) with 1000:1 PWM dimming

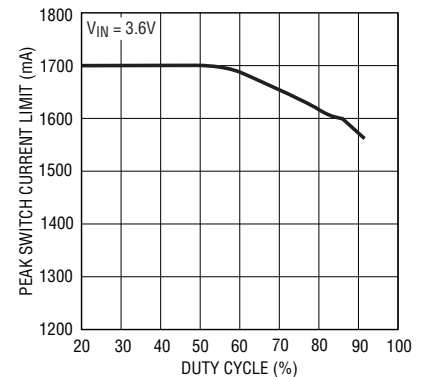

Figure 8. Typical peak switch current limit drops as duty cycle increases above 50%

For more information on parts featured in this issue, go to <http://www.linear.com>