

DESIGN NOTES

High Efficiency White LED Driver Guarantees Matching LED Brightness – Design Note 267

Dave Kim

Introduction

White LEDs are widely used in small LCD backlight applications for simplicity, high reliability and low cost. However, due to variations in the forward voltage drop of white LEDs, matching the brightness becomes a major design consideration for multiple LED applications. Since LED brightness is proportional to current rather than voltage, a constant-current source driving LEDs in series should be used to ensure the same illumination of each LED. The LT[®]1932 uses a constant-current step-up architecture that directly regulates the LED current and guarantees a constant light intensity in each LED, regardless of differences in their forward voltage drops. Its unique internal current source accurately regulates LED current even when the input voltage is higher than the LED voltage, greatly simplifying the battery/adaptor power designs. The internal 36V switch is capable of driving up to eight LEDs in series with 20mA of LED current.

The LT1932 comes in the tiny 1mm, ThinSOT[™] package. It operates at a constant 1.2MHz switching frequency, permitting the use of tiny, low profile chip inductors and capacitors to minimize circuit size and cost in space-conscious portable applications such as cellular telephones and handheld computers.

LT, LTC and LT are registered trademarks of Linear Technology Corporation. ThinSOT is a trademark of Linear Technology Corporation.

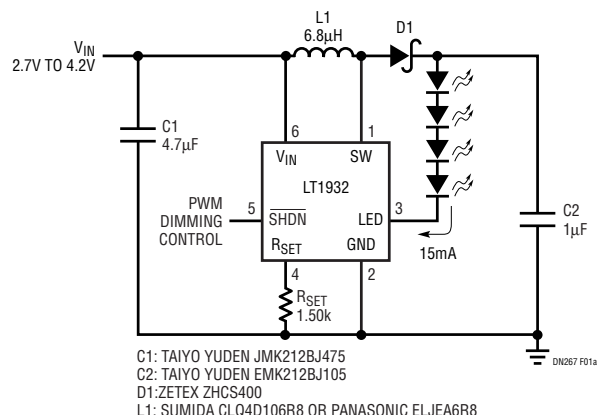

Li-Ion LED Driver for Four White LEDs

The white LED driver shown in Figure 1 is an ideal solution for Li-Ion powered, 4-LED backlight applications. The LT1932 and five external components require less than 0.65cm² of printed circuit board space.

The constant-frequency step-up topology provides low noise, high efficiency and matched LED brightness along with adjustable current control. The LT1932 permits no LED current during shutdown, resulting in less than 1µA of battery current in the standby mode. The LED current is easily programmed over a range of 5mA to 40mA by selecting the value of R_{SET} as shown in Table 1. By applying an additional DC voltage or a pulse-width modulated (PWM) signal to the R_{SET} pin, the LED current can be adjusted for dimming or brightness control.

Table 1. R_{SET} Resistor Values

I _{LED} (mA)	R _{SET} VALUE (Ω)
40	562
30	750
20	1.13k
15	1.50k
10	2.26k
5	4.53k

Efficiency

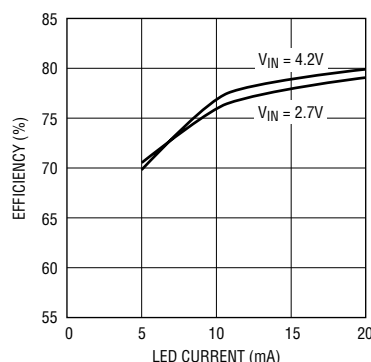

Figure 1. Li-Ion (or 5V) LED Driver for Four White LEDs

Dimming Control

The brightness of the LED can be easily adjusted using a PWM signal, a filtered PWM signal, a logic signal or a DC voltage. Five LED dimming schemes are shown in Figure 2. The LT1932 using PWM brightness control provides the widest dimming range and the purest white LED color over the entire dimming range. This results in better than a 20:1 dimming ratio without the undesirable blue tint common to white LED backlights. PWM controlled LED current is shown in Figure 3. Average LED current changes with duty cycle by switching between full current and zero current. This ensures that when the LEDs are on, they can be driven at the appropriate current to give the purest white light (at 15mA or 20mA) while the light intensity changes with the PWM duty cycle. See the LT1932 data sheet for more information about the dimming control methods shown in Figure 2.

Conclusion

For multiple white LED backlight applications, a constant current, series LED driver is required to ensure the light

intensity matching in each LED. The constant current topology and 36V internal switch make the LT1932 an ideal solution for multiple white LED driver applications. The LT1932 features the purest white LED color dimming control, less than 1 μ A standby mode quiescent current, selectable current level, guaranteed LED brightness matching and extremely small circuit size making it well suited for portable cellular phone and handheld computer applications.

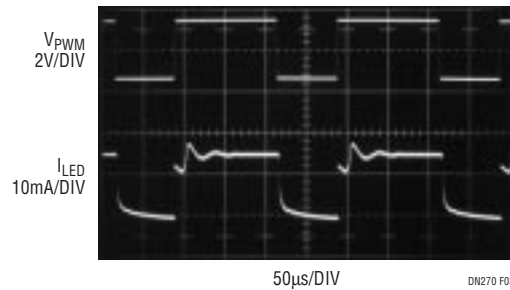

Figure 3. PWM Dimming Using the SHDN Pin

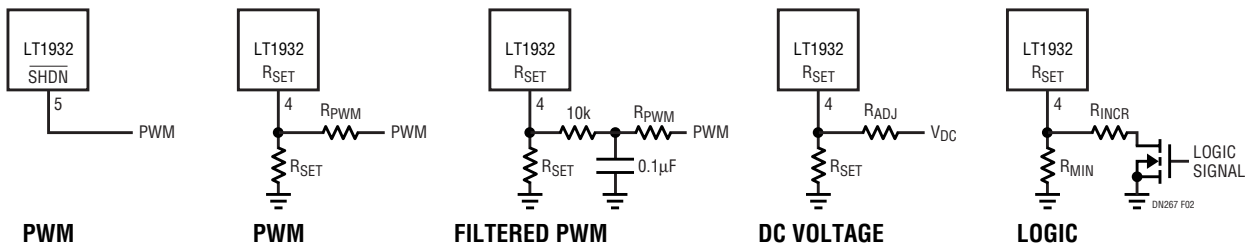

Figure 2. Five Methods of LED Dimming

Data Sheet Download

<http://www.linear.com/go/dnLT1932>

For literature on our DC/DC Converters, call **1-800-4-LINEAR**. For applications help, call (408) 432-1900, Ext. 2759