

# DESIGN NOTES

## Triple LED Driver in 4mm × 5mm QFN Supports LCD Backlights in Buck, Boost or Buck-Boost Modes and Delivers 3000:1 PWM Dimming Ratio

Design Note 449

Hua (Walker) Bai

### Introduction

By integrating three independent LED drivers, the LT<sup>®</sup>3496 offers a highly efficient, compact and cost-effective solution to drive multiple LED strings. All three drivers have independent on/off and PWM dimming control, and can drive different numbers or types of LEDs. High side current sensing and built-in gate drivers for PMOS LED disconnect allow the LT3496 to operate in buck, boost, SEPIC or buck-boost modes with up to 3000:1 True Color PWM<sup>™</sup> dimming ratio.

The LT3496 is offered in a single 4mm × 5mm QFN or FE28 package. The efficiency of each driver can exceed 95%.

### Integrated PMOS Drivers Improve PWM Dimming Ratio to 3000:1

A high PWM dimming ratio is critical in many display applications, especially in high end LCD panels. Beware, though, the definition of dimming ratio varies among suppliers. When comparing dimming ratios, pay close attention to the PWM dimming frequency and linearity of the LED average current at different PWM duty cycles. For instance, the LT3496's high 3000:1 PWM dimming ratio can be achieved at a 100Hz PWM frequency—high enough to keep the display flicker-free over the entire dimming range.

LT, LTC and LTM are registered trademarks and True Color PWM is a trademark of Linear Technology Corporation. All other trademarks are the property of their respective owners.

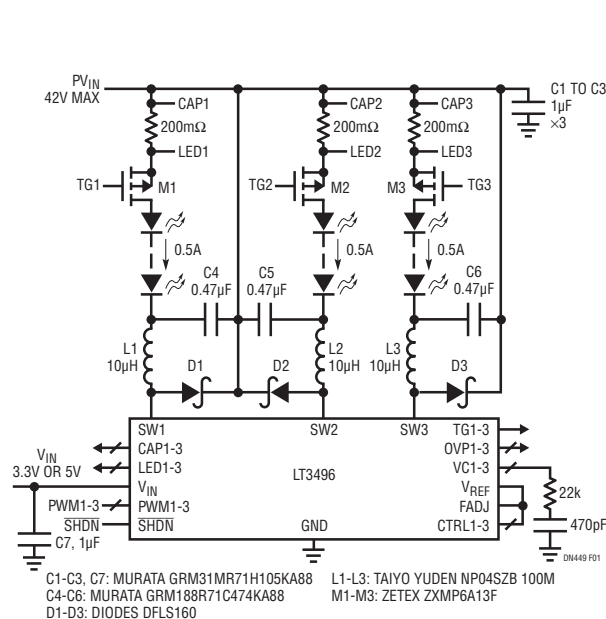

Figure 1. Triple Buck Mode Can Drive 3x 500mA LED Strings

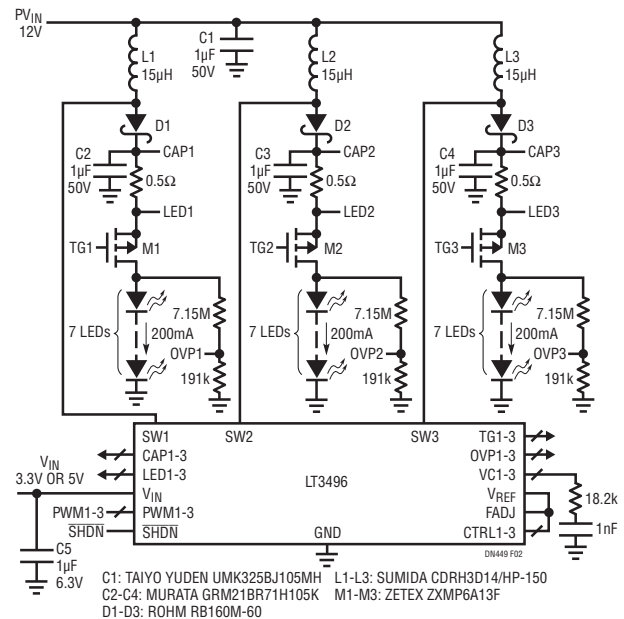

Figure 2. Triple Boost Mode Can Drive 200mA LEDs

### Buck Mode Circuit Drives Three 500mA LED Strings

Figure 1 shows a triple buck mode LED driver. Each channel drives 500mA of current to its LEDs. Each string can have from eight to twelve LEDs, depending on type. The 2.1MHz switching frequency minimizes the solution size by allowing the use of low profile inductors and capacitors. The overall size of the circuit is less than 16mm × 16mm, with a maximum height of 1.5mm.

Efficiency can be above 95% for a LT3496 buck mode driver. A further reduction in the parts count is possible by removing M1, M2 and M3. However, the dimming ratio drops without those MOSFETs. To improve the efficiency, the  $V_{IN}$  pin should be biased from a 3.3V or 5V supply. Energy to the LEDs is supplied by  $PV_{IN}$ . OVP protection is omitted in Figure 1.

### Boost Mode Circuit Drives Three 200mA LED Strings

Figure 2 shows a triple boost mode driver that delivers 200mA to each LED string from a regulated 12V. Figure 3 shows the superior PWM dimming performance of the circuit. The LED current reaches a programmed 200mA in less than 500ns. The efficiency of this circuit is 90% at a 2.1MHz switching frequency. Unlike the buck mode driver, the boost mode and buck-boost mode drivers always require an OVP circuit at the output for open LED protection.

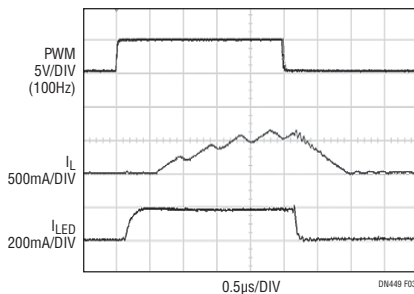

**Figure 3. Achieving Greater Than 3000:1 PWM Dimming Ratio with a PMOS Disconnect**

### Buck-Boost Mode Circuit Survives Load Dump Events

In automotive applications, load dump is a condition under which an IC is expected to experience 40V transient. In such applications, the LED string voltage often falls in the middle of the 8V to 40V input supply range, thus requiring buck-boost mode.

In a buck-boost circuit, the switch voltage is the sum of the input voltage and the LED voltage. Therefore, it is necessary to turn off the internal power switch before the input voltage gets too high. The LT3496 circuit in Figure 4 drives four LEDs, at 200mA per channel. The circuit monitors the Schottky diodes' cathode voltage ( $V_{SC}$ ). The OVP logic turns off the main switch when  $V_{SC}$  is above 38V, preventing the switch voltage from rising further. Since no IC pin experiences absolute maximum voltage, the circuit survives the load dump event.

### Conclusion

Multiple output LED drivers, such as the LT3496, offer excellent current matching, efficiency and space savings. The flexibility to operate in buck, boost or buck-boost mode makes the LT3496 feasible in many rugged applications.

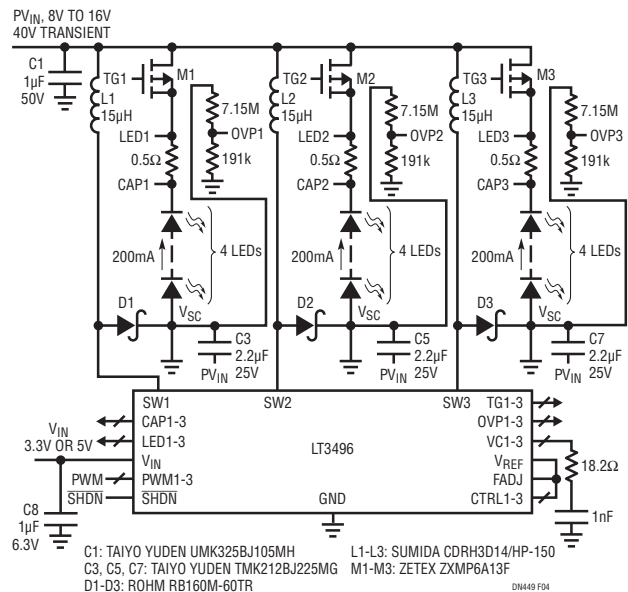

**Figure 4. Triple Buck-Boost Mode Can Drive 200mA LEDs While Surviving Load Dump**

[Data Sheet Download](#)

[www.linear.com](http://www.linear.com)

For applications help,  
call (408) 432-1900, Ext. 2759