

APPLICATION NOTE 1736

Powering Four White LEDs with High Efficiency Using the MAX1848

The MAX1848 boost converter integrates a 14V N-channel MOSFET to power three white LEDs in series. Due to the low $R_{ds(on)}$ and low gate capacitance of the 14V switch, the MAX1848 achieves higher efficiency than competing boost converters using 30V switches. However, the MAX1848 cannot support more than three series-connected white LEDs. For applications using four LEDs, simply arrange them in two legs of two LEDs, as in **Figure 1**.

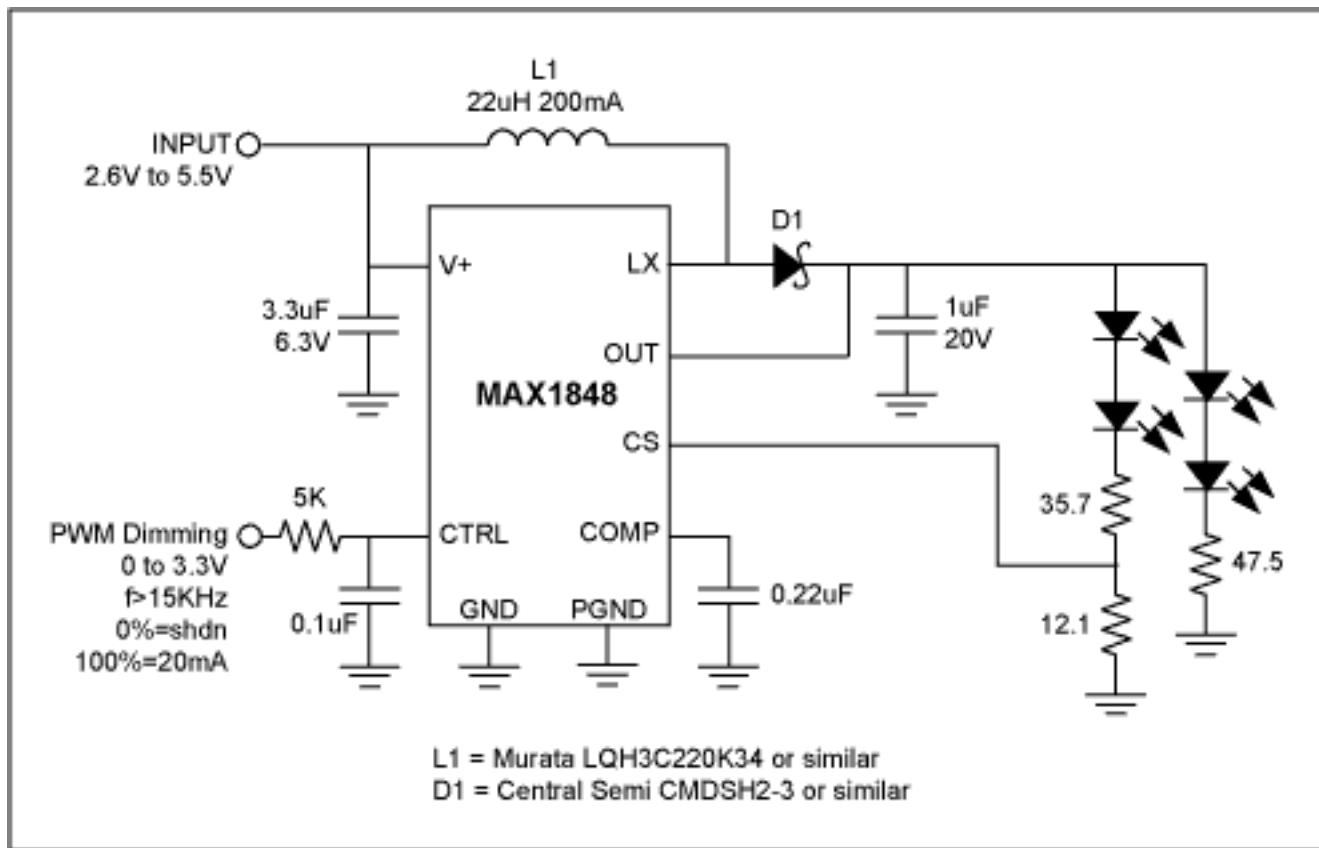

Figure 1. The MAX1848 can power four white LEDs (two legs of two series-connected LEDs) with higher efficiency than competing 30V boost converters.

It should be noted that the MAX1848 utilizes a very low threshold voltage at CS (7.5% of V_{ctrl}) to minimize power loss in the current-sense resistor, which increases efficiency in three LED applications. However, with multiple legs, good leg-to-leg current matching requires additional ballast resistance. In this design, first select the current sense resistor as:

$$R_{sense} = 7.5\% \frac{V_{CTRLmax}}{I_{LED}} = 0.075 \frac{3.3V}{20mA} = 12.375\Omega \approx 12.1\Omega$$

For reasonable leg-to-leg matching, the ballast resistance should be at least 20 Ω per LED, or 40 Ω for two LEDs in series. To simplify the design, select standard 1% resistor values of 35.7 Ω and 12.1 Ω (47.8 Ω total) for the first leg and 47.5 Ω for the second leg. Larger ballast resistance will improve matching but hurt efficiency.

For LED dimming control, a PWM signal is R-C low-pass filtered and applied to CTRL. The MAX1848 regulates LED current linearly from 0% duty-cycle (zero current) to 100% duty-cycle (maximum current). Additionally, the circuit automatically enters 1 μ A shutdown mode at duty-cycles of 5% or less, eliminating the need for additional control lines. A 5 kil Ω plus 0.1 μ F R-C filter is sufficient for PWM frequencies greater than 15KHz. For lower frequencies, the capacitance should be increased because increasing the resistance will cause error in the LED current. If an analog voltage is available from a DAC output, then the R-C filter is not needed.

The circuit of Figure 1 was built and tested with four surface-mount white LEDs. **Figure 2** demonstrates PWM dimming control, shutdown, and leg-to-leg matching. **Figure 3** shows efficiency versus dimming and input supply voltage. Competing 30V boost converters are typically 10% less efficient, especially when dimming.

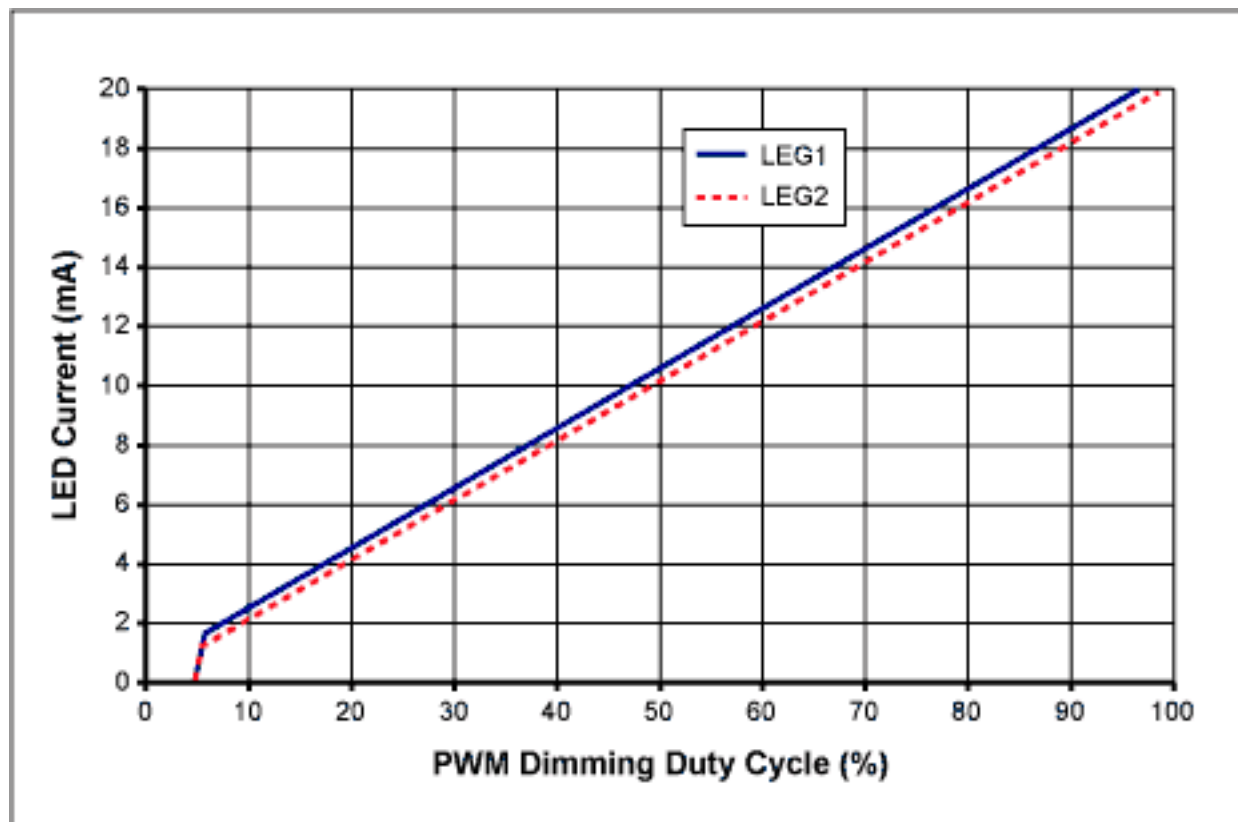

Figure 2. PWM dimming adjusts LED current and controls 1 μ A shutdown mode. Leg-to-leg current matching is good (better than 0.5mA).

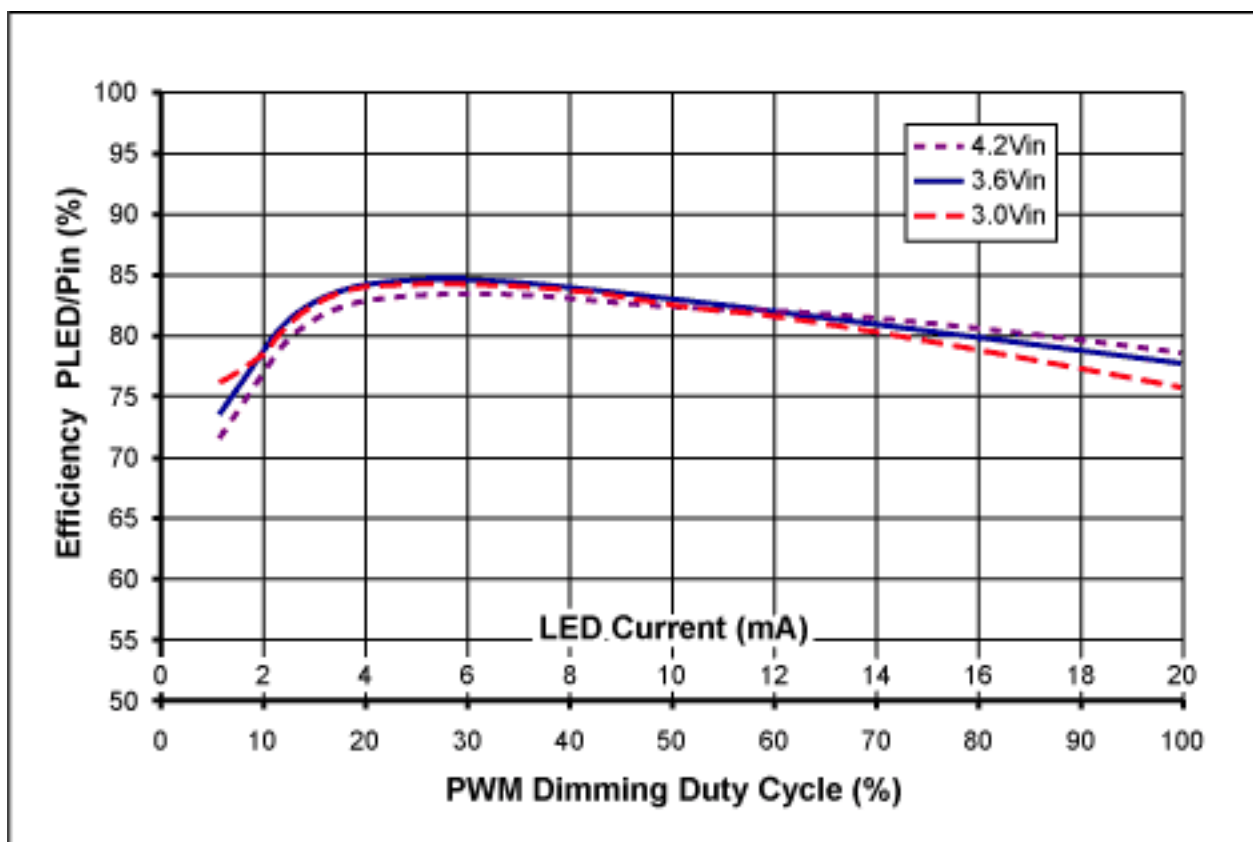

Figure 3. Efficiency remains very high across the input supply voltage range and LED dimming range, extending battery life in portables.

There are several other advantages that make the MAX1848 attractive compared to competitive solutions:

1. **Open-circuit protection eliminates zener diode.** The MAX1848 limits the output voltage to safe levels in the case of a failed LED or display connector. Competing devices require an expensive zener diode to prevent destroying their MOSFET.
2. **Very low 5mVpp input ripple.** The MAX1848 operates at 1.2MHz in continuous conduction mode. Most competing devices switch at slower frequencies and in discontinuous conduction, resulting in more than 100mVpp input ripple, which may negatively impact other circuits in the device.
3. **Soft-start eliminates in-rush current.** During start-up, the MAX1848's input current never exceeds its in-regulation value. Competing devices do not include soft-start or use less effective soft-start techniques, causing significant voltage droop on the battery during start-up.
4. **Small packaging options.** The MAX1848 is available in 8-pin SOT23 (3.0x3.0x1.45mm) and QFN (3.0x3.0x1.0mm) packages. Upon request, the MAX1848 may be packaged in chip-scale UCSP (1.55x1.55x0.61mm).
5. **CTRL input for dimming and shutdown.** The MAX1848 is easily dimmed using an analog voltage from a DAC or a low-pass filtered PWM signal. The dimming range is linear from near zero current to full current. The 1 μ A shutdown mode is via the same CTRL input, so no other signal lines are needed. Competing devices offer dimming only as an applications after thought.
6. **Low feedback voltage at CS to improve efficiency.** The current sense threshold is only 7.5% of V_{ctrl} to reduce wasted power in the sense resistor. Some competing devices have 1.25V feedback thresholds.

Application Note 1736: <http://www.maxim-ic.com/an1736>

More Information

For technical questions and support: <http://www.maxim-ic.com/support>

For samples: <http://www.maxim-ic.com/samples>

Other questions and comments: <http://www.maxim-ic.com/contact>

Related Parts

MAX1848: [QuickView](#) -- [Full \(PDF\) Data Sheet](#) -- [Free Samples](#)

AN1736, AN 1736, APP1736, Appnote1736, Appnote 1736

Copyright © by Maxim Integrated Products

Additional legal notices: <http://www.maxim-ic.com/legal>