

APPLICATION NOTE 3256

Why Drive White LEDs with Constant Current?

When applying white LEDs for display backlighting or other illumination applications, there are two reasons to drive them with constant current:

1. To avoid violating the Absolute Maximum Current Rating and compromising the reliability.
2. To obtain predictable and matched luminous intensity and chromaticity from each LED.

This application note describes the characteristics of a range of typical LEDs and circuits which achieve the necessary constant-current drive.

The forward current vs. forward voltage of six random white LEDs (three from each of two manufacturers) is shown in **Figure 1**. In this case, driving these six LEDs with 3.4V, for instance, will cause their forward current to vary from 10mA to 44mA, depending upon the LED.

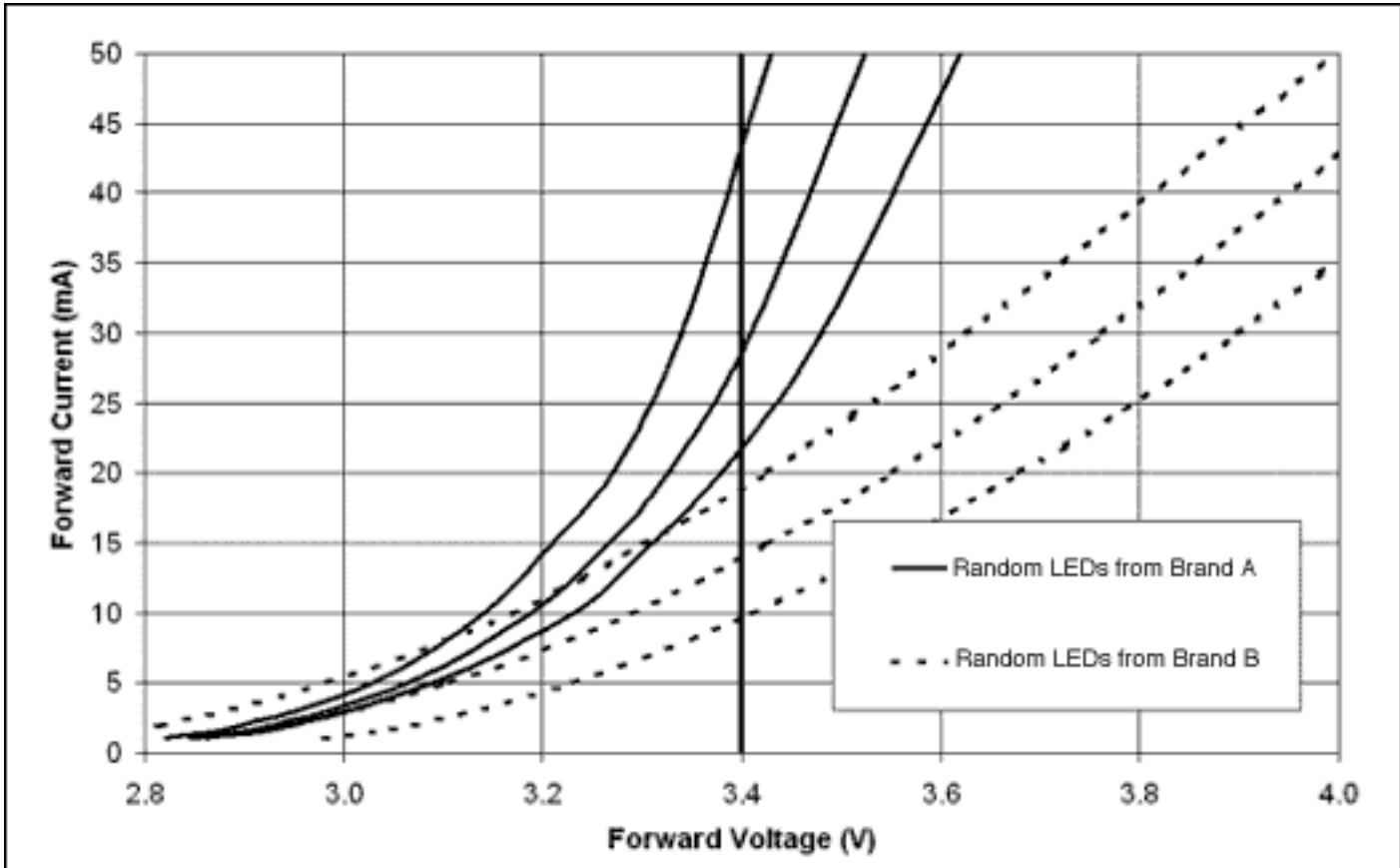

Figure 1. Forward Current versus Forward Voltage for six random white LEDs (three from each of the two leading manufacturers). Note that the forward current at any given voltage varies widely—10mA to 44mA at 3.4V, for instance.

For reliability, it is important to not violate the LEDs absolute maximum current rating. A typical value might be 30mA abs. max., but as shown in **Figure 2**, the maximum current is de-rated to handle increasing ambient

temperature. It is common to limit the current to 20mA for use up to 50 degrees centigrade. By combining the information in Figures 1 and 2, it is obvious that driving white LEDs with constant voltage is not a reliable solution.

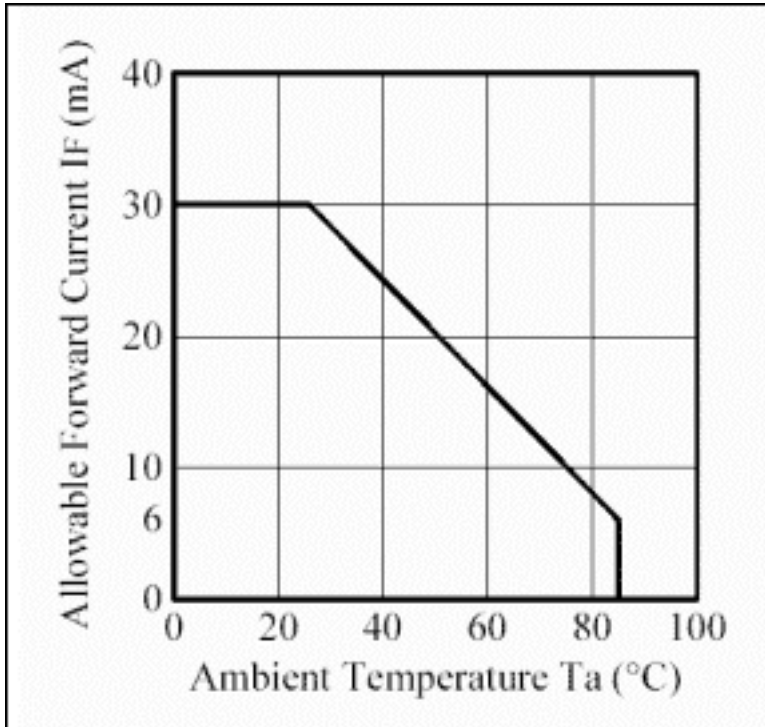

Figure 2. The absolute maximum forward current rating of a white LED is typically de-rated as ambient temperature increases. (Courtesy Nichia Corporation.)

Furthermore, it is important to note that a white LED's luminous intensity and chromaticity (color) are tested and best controlled by driving it with constant current. A typical white LED specification can be seen in **Figure 3**.

(2) Initial Electrical/Optical Characteristics

($T_a=25^\circ\text{C}$)

| Item | Symbol | Condition | Min. | Typ. | Max. | Unit |
|--------------------|--------|---------------------|------|------|------|---------------|
| Forward Voltage | V_F | $I_F=20[\text{mA}]$ | - | 3.6 | 4.0 | V |
| Reverse Current | I_R | $V_R=5[\text{V}]$ | - | - | 50 | μA |
| Luminous Intensity | Rank T | $I_F=20[\text{mA}]$ | 720 | 860 | 1000 | med |
| | Rank S | $I_F=20[\text{mA}]$ | 500 | 600 | 720 | med |
| | Rank R | $I_F=20[\text{mA}]$ | 360 | 430 | 500 | med |

* Measurement Uncertainty of the Luminous Intensity : $\pm 10\%$

Color Ranks

($I_F=20\text{mA}, T_a=25^\circ\text{C}$)

| Rank a0 | | | | |
|---------|-------|-------|-------|-------|
| x | 0.280 | 0.264 | 0.283 | 0.296 |
| y | 0.248 | 0.267 | 0.305 | 0.276 |

| Rank b1 | | | | |
|---------|-------|-------|-------|-------|
| x | 0.287 | 0.283 | 0.330 | 0.330 |
| y | 0.295 | 0.305 | 0.360 | 0.339 |

| Rank b2 | | | | |
|---------|-------|-------|-------|-------|
| x | 0.296 | 0.287 | 0.330 | 0.330 |
| y | 0.276 | 0.295 | 0.339 | 0.318 |

| Rank c0 | | | | |
|---------|-------|-------|-------|-------|
| x | 0.330 | 0.330 | 0.361 | 0.356 |
| y | 0.318 | 0.360 | 0.385 | 0.351 |

* Measurement Uncertainty of the Color Coordinates : ± 0.01

Figure 3. For a typical white LED, the entire electrical specification is tested at $I_F=20\text{mA}$. Therefore, to obtain predictable and matched luminous intensity and chromaticity (color), constant current drive is recommended. (Courtesy Nichia Corporation.)

Figure 4 shows four common power-supply circuits to drive white LEDs. Figure 5 shows the corresponding regulation accuracy when regulating our six random LEDs. In figure 5, the regulator's output load-line characteristic is plotted on top of the LEDs' V_f curves. Where the lines intersect is the regulation point for each LED.

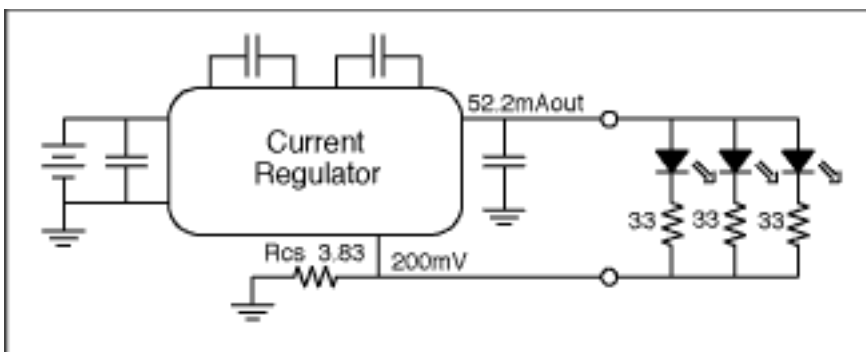
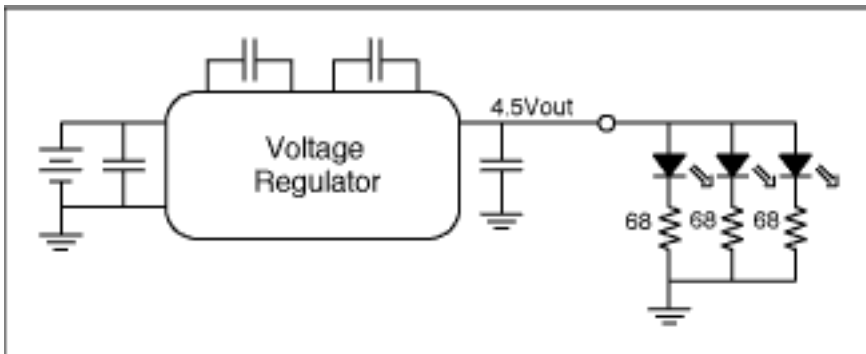

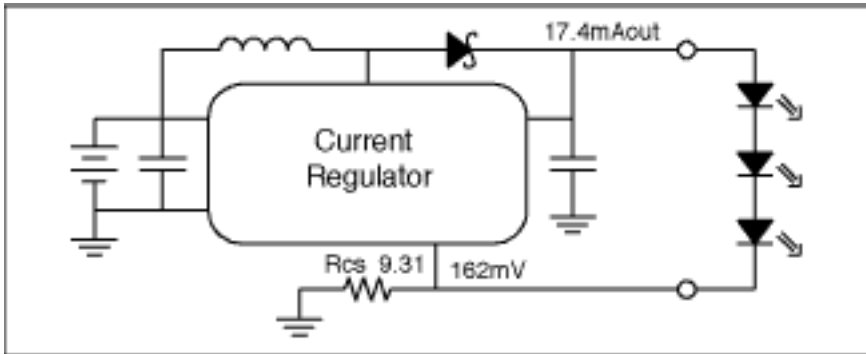
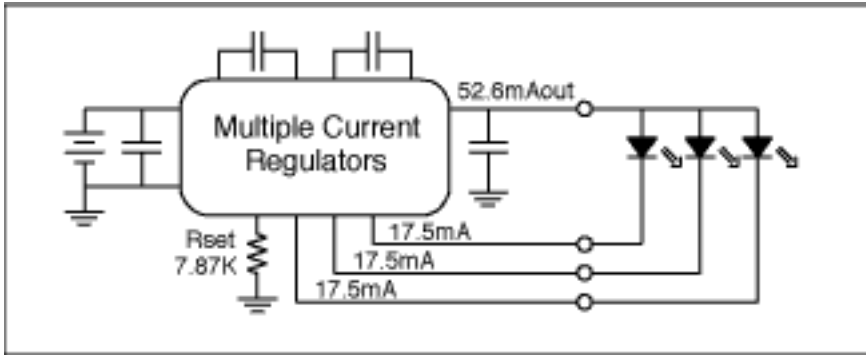
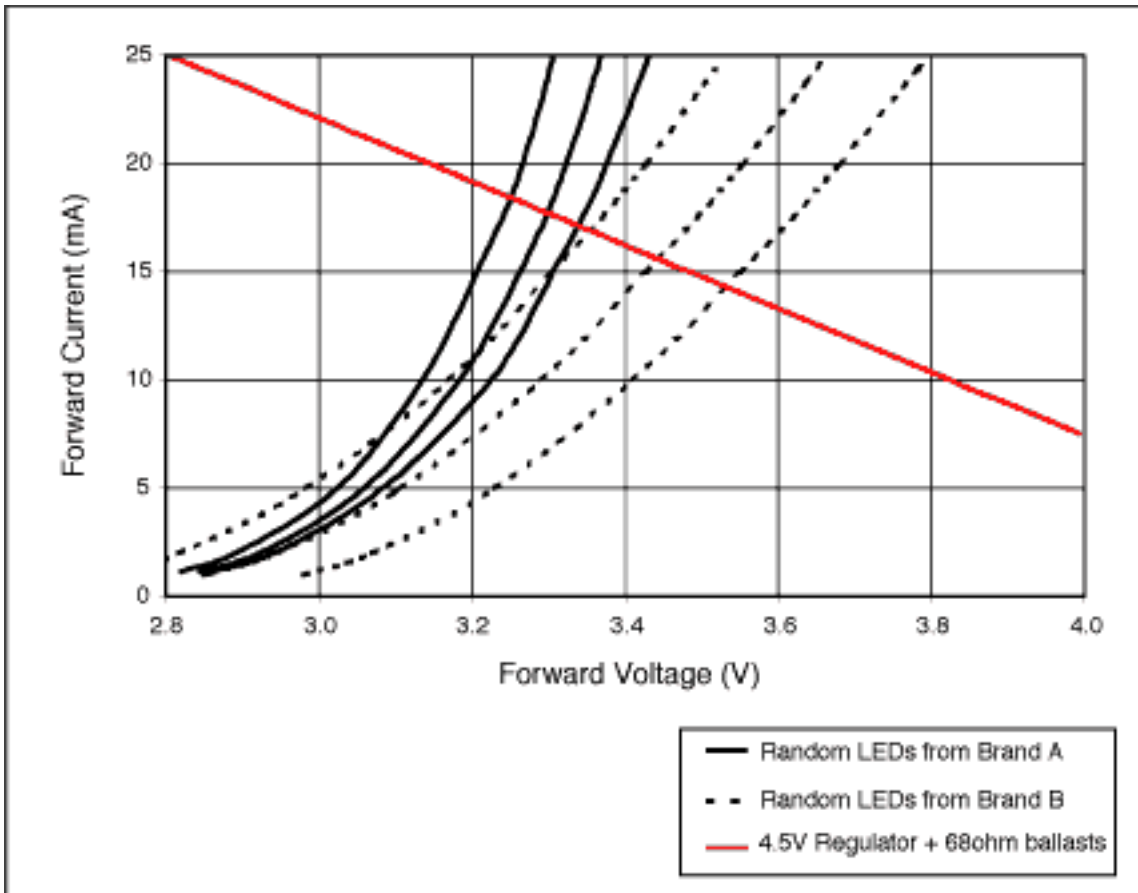

Figure 4. White LEDs are commonly powered in four different ways: (a) a voltage source and ballast resistors, (b) a current source and ballast resistors, (c) multiple current sources, and (d) a current source with the LEDs in a series connection.



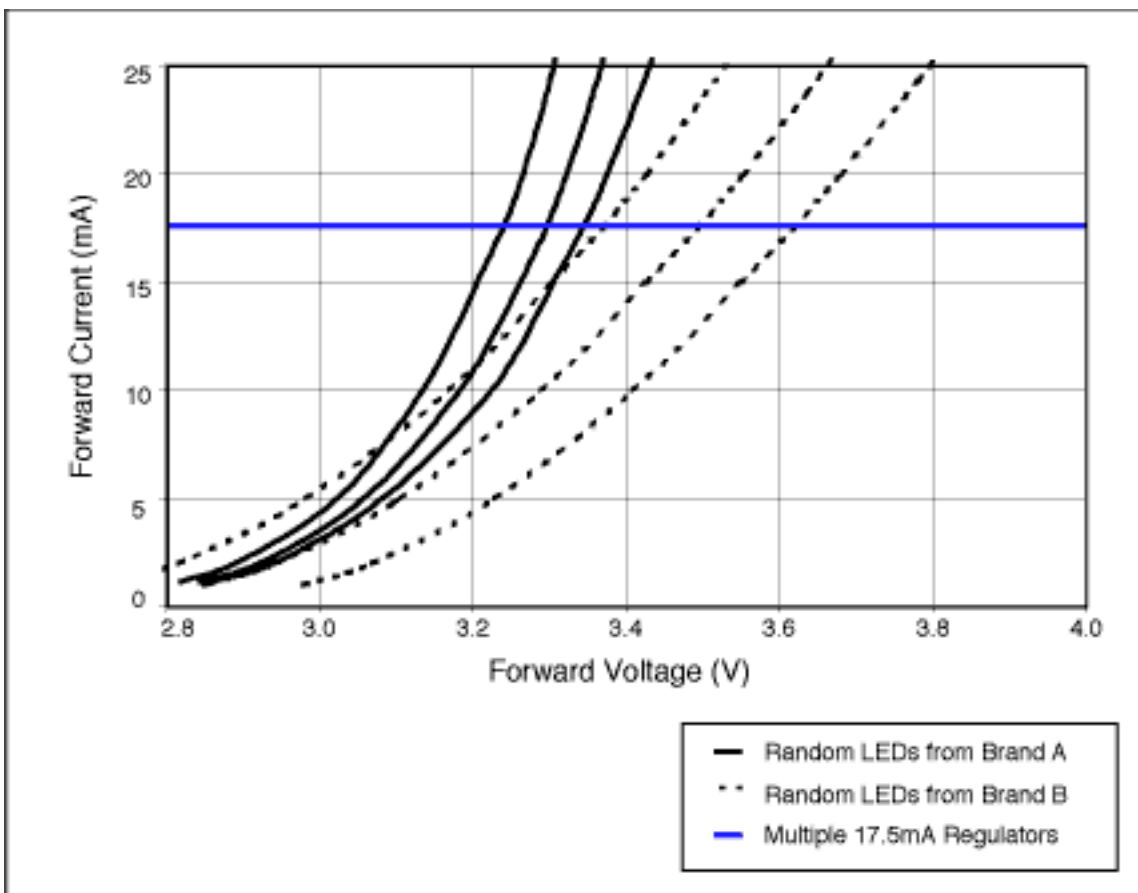
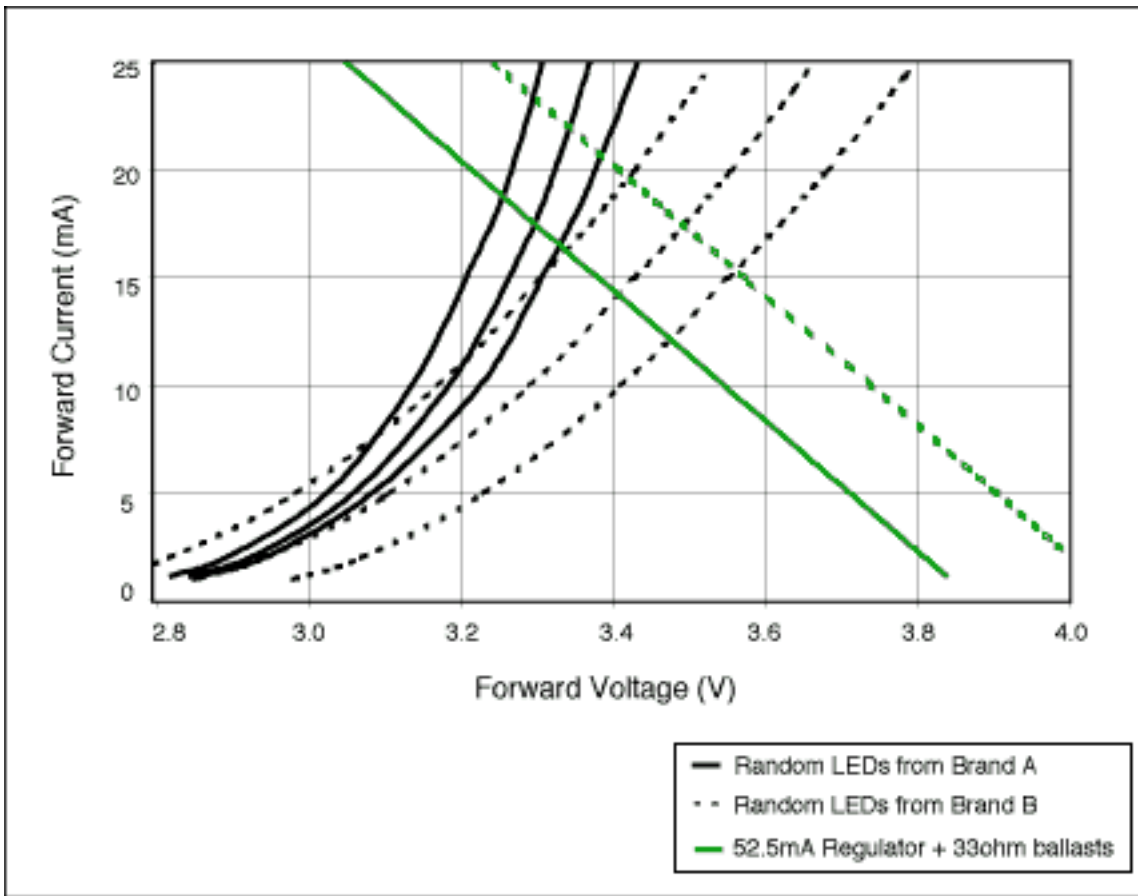

Figure 5. The variation in white-LED forward voltage (V_f) influences the current regulation accuracy differently depending upon the regulation scheme: (a) a voltage source and ballast resistors, (b) a current source and ballast resistors, (c) multiple current sources or a current source with the LEDs in series. The V_f curves of six

random white LEDs (three from Lot A and three from Lot B) are shown. Where the regulator's output Load-Line curve intersects the LED's V_f curve is the regulation point.

The circuit of Figure 4a shows how to use a voltage regulator and ballast resistors to control the LED current. The advantages of this approach are that a great variety of voltage regulators may be applied this way and that only one terminal connects the regulator to the LEDs. The disadvantages are that the efficiency is not very good due to power lost in the ballast resistors and that LED forward current is not accurately controlled. Figure 5a shows that the current in our six random LEDs varies from 14.2 to 18.4mA, while brand A runs about 2mA brighter on average than brand B.

The circuit of Figure 4b regulates the total current applied to the LEDs, while ballast resistors are still used for LED-to-LED matching. The MAX1910 is an example of this type of current regulation. The circuit capitalizes on the fact that the LEDs are better matched within one manufacturer's lot and that most variation is from lot-to-lot or brand-to-brand. Because of this, the ballast resistors can be reduced to waste half as much power while providing similar current control as in the previous circuit. Figure 5b shows that the current in our six random LEDs varies from 15.4 to 19.6mA; however, brand A variation is even less and both brand A and brand B run at the same average current of 17.5mA/LED. The disadvantages are that there still remains significant power loss in the ballast resistors and the LED currents do not match perfectly. Nevertheless, this circuit represents a good compromise between performance and simplicity.

The circuit of Figure 4c regulates the individual current in each LED and requires no ballast resistors. Current regulation accuracy and matching is controlled by the accuracy of the individual current regulators. The MAX1570 is an example of this type of current regulation and exhibits 2% typical current accuracy and 0.3% typical current matching. Because the current regulators are low dropout, the efficiency can be very high. Figure 5c shows that the regulated current is a constant 17.5mA for all six randomly selected white LEDs. The lack of ballast resistors saves board space, but four terminals are required between the regulator and LEDs. This type of circuit represents a high-performance solution that can readily compete with inductor-based solutions.

The circuit of Figure 4d is a high-efficiency inductor-based boost converter configured to regulate current. A low feedback threshold minimizes the power wasted in the current-sense resistor. Because the LEDs are arranged in series, the LED current matches perfectly under all conditions. Current accuracy is determined by the regulator's feedback threshold accuracy and is independent of the LED's forward voltage variation. The MAX1848 and MAX1561 are examples of this type of current regulation and exhibit 87% (3 LEDs) and 84% (6 LEDs) efficiency (P_{LED}/P_{IN}), respectively. Some other advantages include only two terminals between the regulator and LEDs and that the series arrangement of the LEDs is independent of which particular boost converter is used, giving designers much flexibility. The disadvantages include the inductor's size (especially height), cost, and radiated EMI.

Application Note 3256: <http://www.maxim-ic.com/an3256>

More Information

For technical questions and support: <http://www.maxim-ic.com/support>

For samples: <http://www.maxim-ic.com/samples>

Other questions and comments: <http://www.maxim-ic.com/contact>

Related Parts

MAX1561: [QuickView](#) -- [Full \(PDF\) Data Sheet](#)

MAX1570: [QuickView](#) -- [Full \(PDF\) Data Sheet](#)

MAX1848: [QuickView](#) -- [Full \(PDF\) Data Sheet](#)

MAX1910: [QuickView](#) -- [Full \(PDF\) Data Sheet](#) -- [Free Samples](#)

AN3256, AN 3256, APP3256, Appnote3256, Appnote 3256

Copyright © 2005 by Maxim Integrated Products

Additional legal notices: <http://www.maxim-ic.com/legal>