

APPLICATION NOTE 3980

Power Supplies for Next-Generation Automotive Lighting

Abstract: Today's automobiles are using LED and CCFL lighting sources, and both technologies need a power supply. This application note discusses power-supply solutions for LED and CCFL light sources that are optimized for interior and exterior automotive applications.

Introduction

Throughout the history of automobiles light sources always played an important role. Originally cars merely had front lights to find a way in the dark. Soon other light sources, taillights, and indicators were added for security and better organization in growing traffic. Warning and fog lights increased functionality for extreme conditions. Interior light sources such as cluster, dome, map, or courtesy lighting added convenience for the driver and passengers. Except for the earliest models, all these light sources were electrically powered and used incandescent light bulbs.

In recent years light-emitting diodes (LEDs) and cold-cathode florescent lamps (CCFLs) have proved useful as light sources in automobiles. The key advantages of these new light sources are longer lifetime and better efficiency. Typical lifetimes for incandescent bulbs are specified at 10,000h, while florescent bulbs can reach 50,000h and LEDs up to 100,000h. This extended lifetime is a clear improvement for reliability and necessary maintenance, which ultimately reduces service costs. Other LED advantages include: low-voltage operation, low electromagnetic radiation, immunity to mechanical stress, wide operating temperature range, and a wide dimming range. With the ongoing improvements to LED technology it seems that eventually this technology will replace the other lighting options. Nonetheless, today CCFL definitely still has clear advantages in certain applications like backlighting of large areas and wherever high-power unfocussed light is needed.

Incandescent, CCLF, and LED light sources all need an electric power supply, and each technology has its special requirements. The power supplies must also perform additional application-specific functions. This article presents power-supply solutions for LED and CCFL light sources. Design approaches are discussed for various automotive interior and exterior applications.

Applications

Interior Lighting

Interior lighting applications include cluster or instrument backlighting, dome or map reading lights, courtesy lights at doors or in the trunk, and display backlighting. Since display backlighting has special requirements, it will be discussed separately below.

All these interior light applications can use LEDs as a light source. While map and dome lighting are often implemented with one LED, cluster and courtesy lighting normally require more than one LED connected in series. The series connection is preferred to avoid current and, therefore, color mismatch between different LEDs. All the applications need a regulated constant-current source with an integrated dimming function. **Figures 1** and **2** show power-supply ICs with various features optimized for these interior lighting applications.

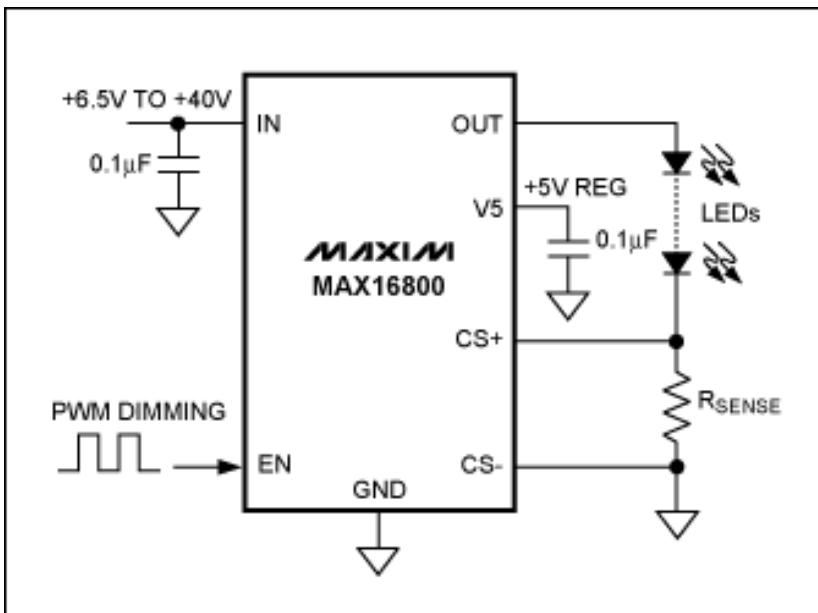

Figure 1. The MAX16800 current regulator operates from a 6.5V to 40V input voltage range and delivers up to a total of 350mA to one or more strings of high-brightness LEDs.

The [MAX16800](#) has a high-input voltage range (up to 40V), so it can connect directly to the car battery without needing further protection against voltage surges caused by load dumps on the battery network. The device generates a constant current for the LEDs that can be set by the sense resistor, R_{SENSE} , in series with the LEDs. To improve the current accuracy and to increase immunity to external noise, the MAX16800 uses a differential current-sense input.

The color of an LED varies with the current flowing through it. Dimming LED brightness is therefore better achieved by pulse-width modulating (PWM) a constant current than by actually changing the current magnitude. The MAX16800 dims LED brightness by applying a PWM signal to the enable input. The current through the LEDs is turned on and off at the rate set by the PWM signal.

Immunity to electromagnetic interference (EMI) is important in automotive applications. It is equally important not to generate EMI. Switching the current on and off through the LEDs is, however, a typical EMI radiation source. Therefore, to reduce the radiated EMI during PWM dimming the MAX16800 uses wave-shaping circuitry to smooth the switching edges.

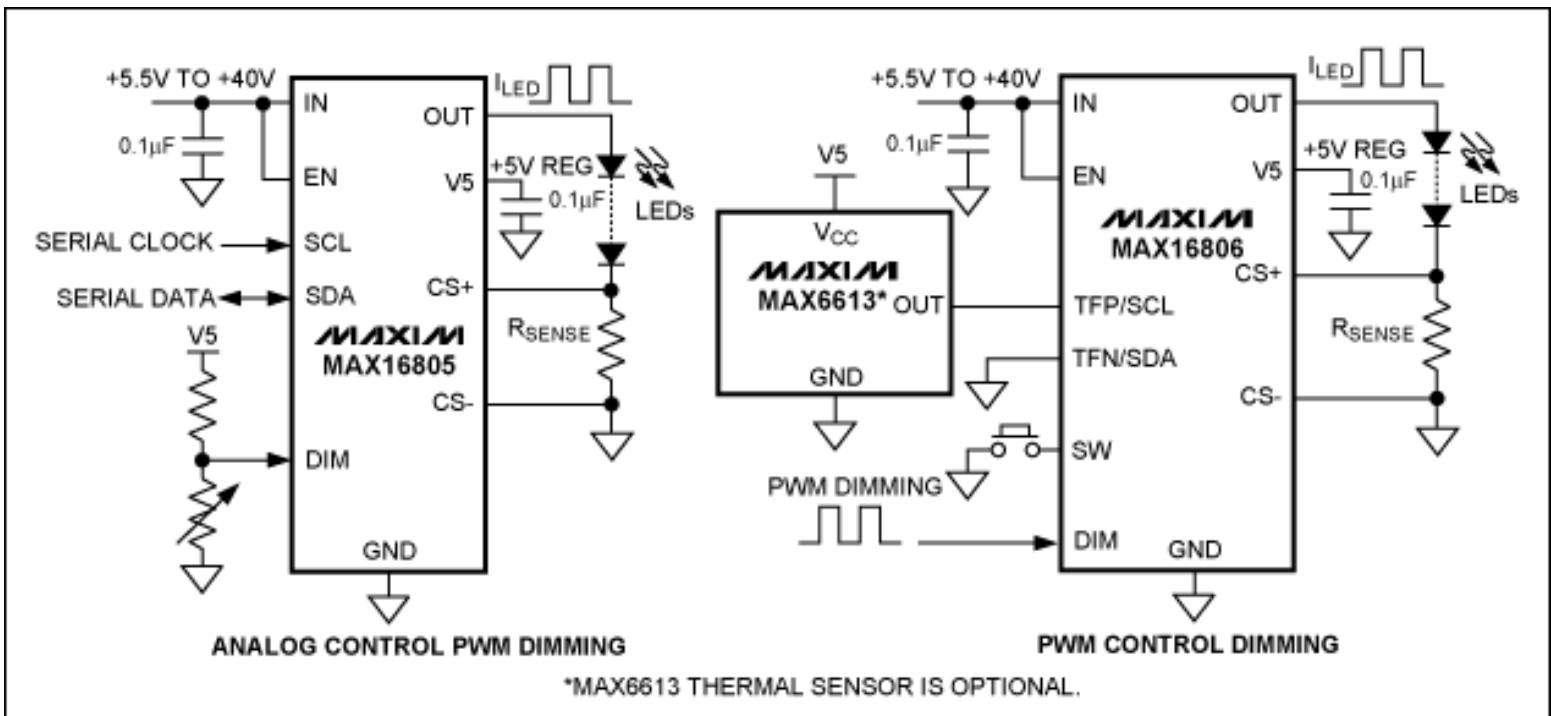

Figure 2. The MAX16805/MAX16806 LED drivers eliminate the need for microcontrollers or switch-mode converters for automotive interior dome, map, and courtesy light applications.

Many lighting applications do not integrate a microcontroller to generate the PWM dimming signal. The [MAX16805/](#)

[MAX16806](#) LED drivers are available for those situations. Both these drivers can generate the PWM signal internally with the modulation set by an external voltage applied to the DIM input. The MAX16806 also has a switch input (SW) to override the analog dim setting. The switch input not only monitors the state of the switch but also has a debounce feature and supplies the switch with a wetting current.

In some lighting applications one must closely monitor LED temperature. This is especially true in space-constrained locations with poor heat dissipation. LED overheating reduces LED lifetime and, therefore, negates one of the key advantages of this light source. Fortunately this overheating can be avoided in most applications by momentarily reducing LED brightness. The MAX16806 has inputs for an external temperature sensor. When an overtemperature is detected, the device increases the dimming until the temperature returns to an acceptable value. The thresholds for temperature and dimming can be programmed with the serial interface and stored in EEPROM memory. This temperature-sensing feature eliminates the need for a costly, large heat sink.

The MAX16805/MAX16806s' internal reference is used in the feedback loop to monitor the LED current, and can be trimmed with the serial interface. This feature allows use of one fixed-sense resistor for all LED bins, and thereby simplifies production and saves cost.

Display Backlighting

Today more and more liquid crystal displays (LCDs) are used to display information in instrument clusters, car computers, radio and navigation systems, and entertainment systems. Unlike the other interior lighting examples discussed above, display backlighting diffuses light across a large area instead of generating a focused light beam.

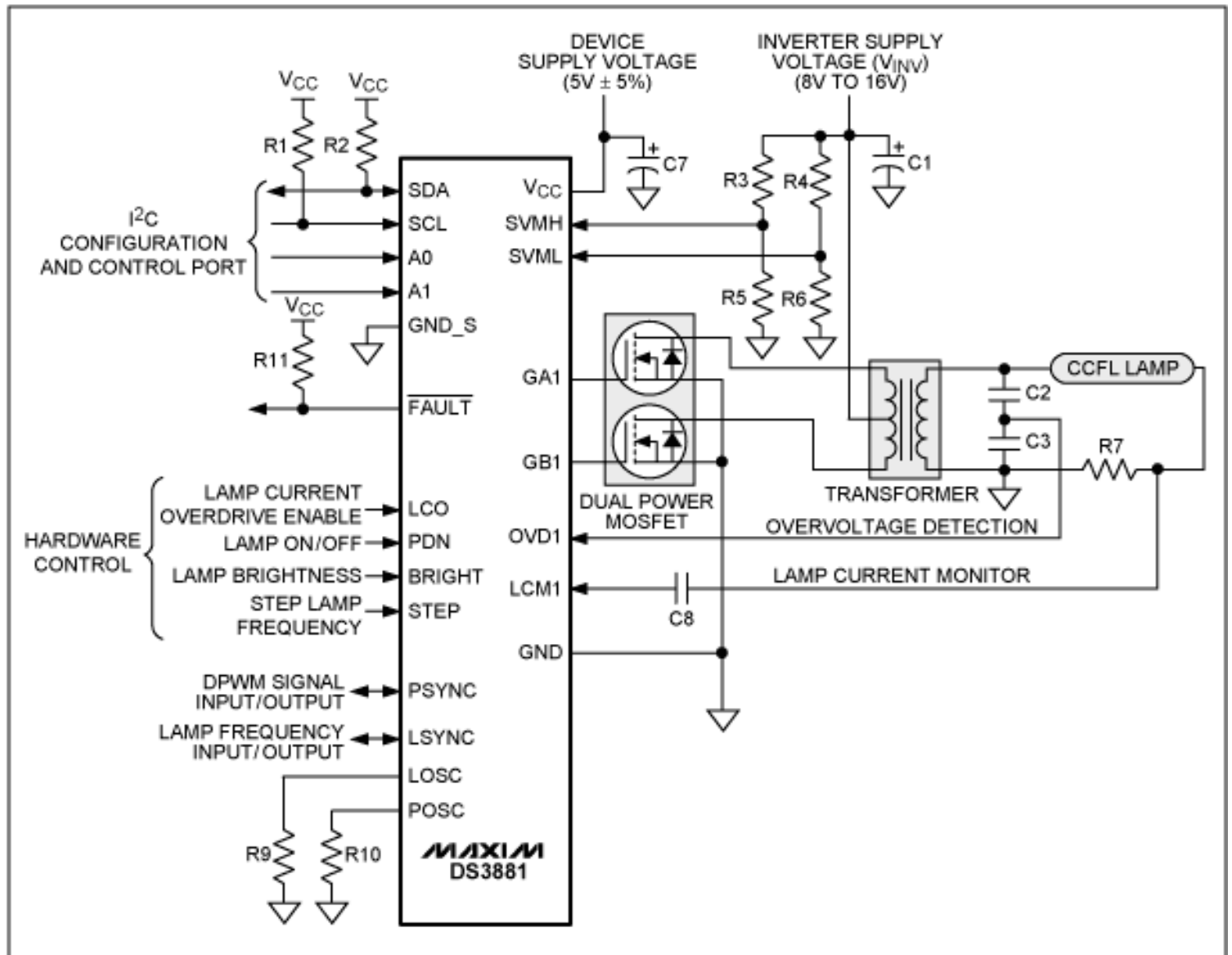

Figure 3. The DS3881CCFL controller features EMI suppression functionality. It provides a lamp current overdrive mode for rapid lamp heating in cold weather conditions.

Traditionally LCD displays use CCFL lamps as a backlight source due to the good efficiency, low temperature, and high illumination power of this technology. Although CCFL controllers have proved successful in nonautomotive applications (i.e., LCD TV or computer monitors), the automotive environment presents special challenges and requirements for the technology.

Because the fundamental CCFL circuit topology has external transistors, a transformer, and the lamp itself, CCFL technology is inherently an EMI source. **Figure 3** shows a power-supply application circuit for a CCFL lamp using the [DS3881](#) CCFL controller optimized for operation in automotive environments. The DS3881 masters this EMI challenge by using spread spectrum and frequency shifting technologies to reduce EMI radiation and to move any remaining noise into uncritical frequency bands.

Another unique automotive requirement is operation at cold temperatures. The DS3881 features a special lamp-current overdrive mode, which enables quick lamp heating at cold temperatures and thereby allows almost instant operation. The DS3881 also features extensive fault monitoring for lamp-fault, lamp-open, overcurrent, failure to strike, and overvoltage conditions.

Due to its high level of integration, the DS3881 needs minimal external components. It reduces the Bill of Materials (BOM) cost and simplifies production. Multiple DS3881 controllers can be cascaded to support large displays requiring more than one lamp. All features and functions can be programmed by wire or with a serial interface; settings can be stored in the integrated nonvolatile memory.

For smaller displays, the alternative to CCFL backlighting is to use a matrix of LEDs. Multiple LED strings pose their own design challenges, notably providing homogenous illumination and color over the full area. **Figure 4** shows a typical circuit of an LED-based LCD backlight.

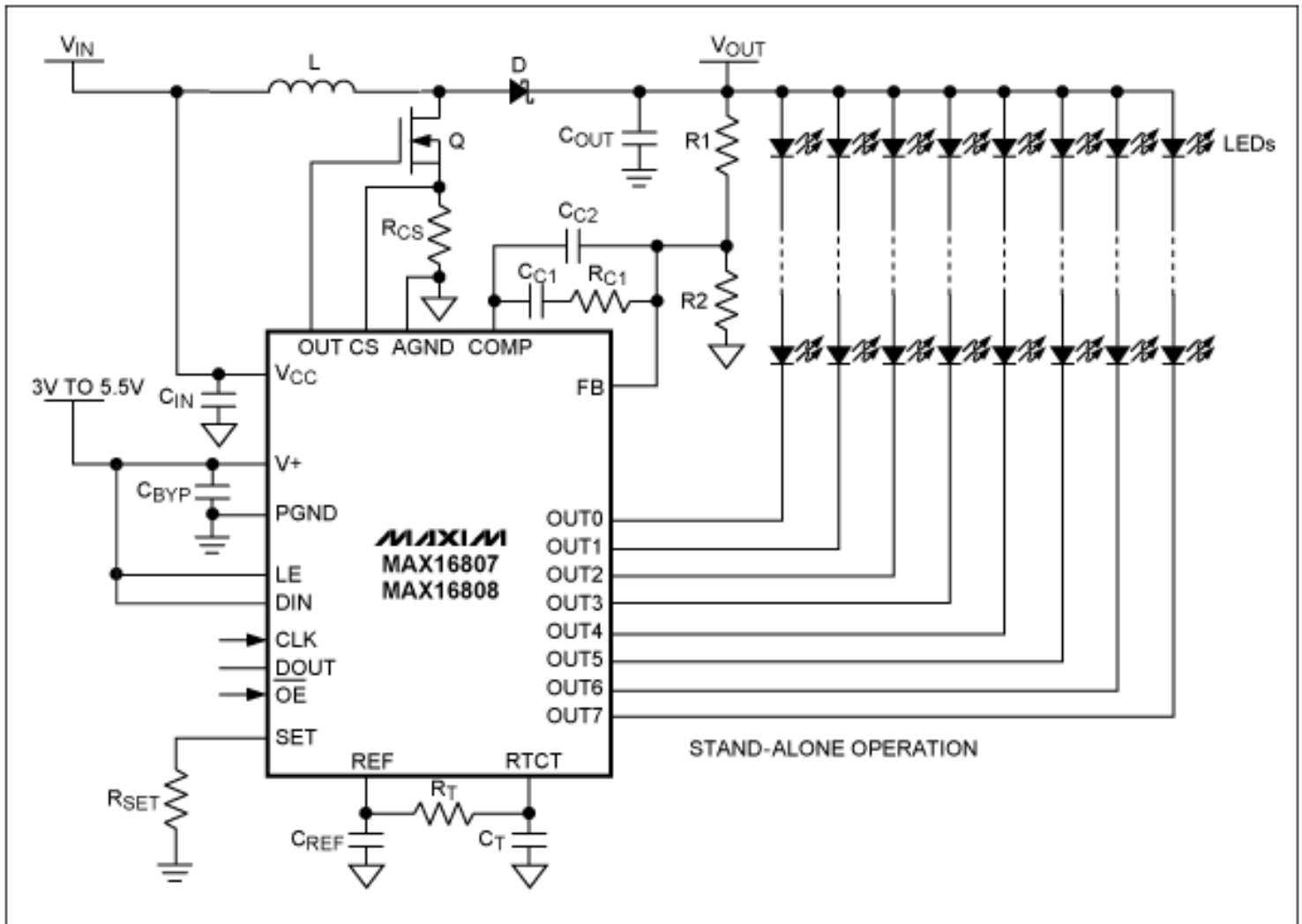

Figure 4. The MAX16807/MAX16808 LED drivers include eight open-drain, constant-current-sinking LED driver outputs rated for 36V continuous operation. The LED current-control circuitry achieves $\pm 3\%$ current matching among strings and enables paralleling of outputs for LED string currents higher than 55mA.

The [MAX16807/MAX16808](#) can be used in buck, boost, or SEPIC mode depending on the input voltage range and the

number of LEDs in series per output string. Adding an external resistor and a zener diode makes the device load-dump proof. While the current through all strings is set by only one resistor, the current of each string is regulated individually. This architecture achieves better than 3% current matching between the individual strings without needing additional external components. While each string can be dimmed individually to adjust for binning mismatches, all strings can be dimmed together through the enable pin. With a dimming frequency range of 50Hz to 30kHz, a dimming ratio of 5000:1 can be achieved. This high ratio is necessary for automotive displays that must be viewable both in the dark and sunlight. The adjustable switching-frequency range from 20kHz to 1MHz makes it possible to select a frequency that will not interfere with other systems like radio receivers. The MAX16808 adds fault-monitoring features for open-circuit LEDs. The parts can be cascaded to create larger LED matrices.

Exterior Lighting

Exterior lighting applications raise new issues of security and safety, and demands for even more high-power illumination. External lighting like taillights, indicators, or emergency warning lights (and fog lights to a lesser extent) must always be available to avoid serious security problems.

Taillights need to be visible over long distances but must not illuminate a wide area. LEDs, with the same current specifications as in interior lighting, work for these exterior applications. The MAX16800/MAX16807/MAX16808 power supplies are also appropriate for this application. Because the number of LEDs in a taillight is typically higher than in the interior applications, more than one of these power supplies will be needed. Multiple power supplies also provide the necessary redundancy to guarantee operation even if one of the circuits fails. This same redundancy can also be used for the indicators or other signaling applications.

Very high-brightness LEDs (HB LEDs) must be used for applications that require high illumination power like floodlights or fog lights. HB LEDs require very high currents, which cannot be supplied economically by the parts discussed above. It would simply take too many devices to generate the necessary currents. The solution for these HB LED applications is the [MAX16818](#) (Figure 5), which can provide up to 30A of current.

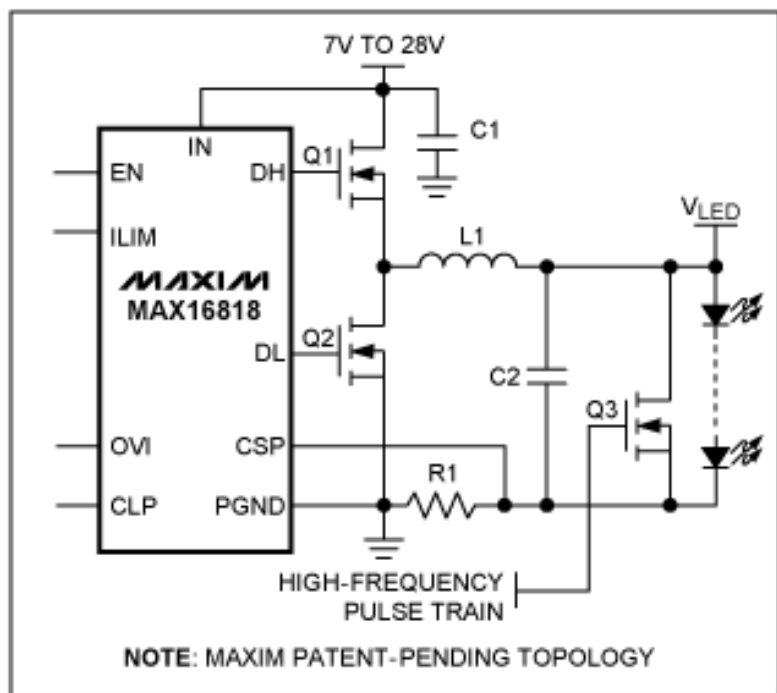

Figure 5. The MAX16818 LED driver utilizes average-current-mode control that enables optimal use of MOSFETs with optimal charge and on-resistance characteristics. This minimizes the need for external heatsinking even when delivering up to 30A of LED current.

The MAX16818 can be operated in buck, boost, and SEPIC mode. The device's wide switching-frequency range, up to 1.5MHz, allows the use of small external components. Exterior lighting applications must typically turn on fast or switch brightness instantaneously. To achieve this, the MAX16818 is the first LED driver that uses Maxim's patent-pending, average-current-mode-control technology for fast LED current transients of up to 20A/μs. For applications where even higher currents or redundancy are required, the MAX16818 features a 180° delayed clock output to control a second LED driver.

Summary

Maxim has expanded its switching and linear regulator portfolio to cover all automotive lighting applications implemented today. This ever-growing range of power-supply solutions will guarantee automotive lighting designers and suppliers a complete, long-term selection of products to match their needs.

All solutions presented here fulfill the general automotive requirements of short-circuit protection, thermal shutdown, and -40°C to +125°C operation. The parts are available in small, thermally enhanced QFN or TSSOP packages that can easily be assembled into the space-limited electronic modules of today's automotive lighting applications.

A similar article appeared in German in *Automotive Hanser* in June 2007.

Application Note 3980: www.maxim-ic.com/an3980

More Information

For technical support: www.maxim-ic.com/support

For samples: www.maxim-ic.com/samples

Other questions and comments: www.maxim-ic.com/contact

Automatic Updates

Would you like to be automatically notified when new application notes are published in your areas of interest? [Sign up for EE-Mail™](#).

Related Parts

DS3881: [QuickView](#) -- [Full \(PDF\) Data Sheet](#) -- [Free Samples](#)

MAX16800: [QuickView](#) -- [Full \(PDF\) Data Sheet](#) -- [Free Samples](#)

MAX16805: [QuickView](#) -- [Full \(PDF\) Data Sheet](#) -- [Free Samples](#)

MAX16806: [QuickView](#) -- [Full \(PDF\) Data Sheet](#) -- [Free Samples](#)

MAX6613: [QuickView](#) -- [Full \(PDF\) Data Sheet](#) -- [Free Samples](#)

MAX6818: [QuickView](#) -- [Full \(PDF\) Data Sheet](#) -- [Free Samples](#)

AN3980, AN 3980, APP3980, Appnote3980, Appnote 3980

Copyright © by Maxim Integrated Products

Additional legal notices: www.maxim-ic.com/legal