

High-Voltage, 100mA/200mA Adjustable Linear High-Brightness LED Drivers with PWM Dimming

General Description

The MAX16815/MAX16828 current regulators operate from a 6.5V to 40V input voltage range and deliver up to 100mA (MAX16815) or 200mA (MAX16828) to high-brightness LED (HB LED) loads. The output current is adjusted by using an external current-sense resistor in series with the LEDs. The MAX16815/MAX16828's dimming input allows wide-range "pulsed" PWM operation. An on-board pass element minimizes external components while providing $\pm 3.5\%$ output-current accuracy.

The MAX16815/MAX16828 are available in a thermally enhanced, 3mm x 3mm, 6-pin TDFN package with exposed pad and are specified over the automotive -40°C to +125°C temperature range.

Applications

Automotive Interior: Map, Courtesy, and Cluster Lighting
Automotive Exterior: Rear Combination Lights (RCLs)
Emergency Vehicle Warning Lights
Signage and Indicators
Ambient and Architectural Lighting
LED Bulbs
Display Backlighting

Pin Configuration

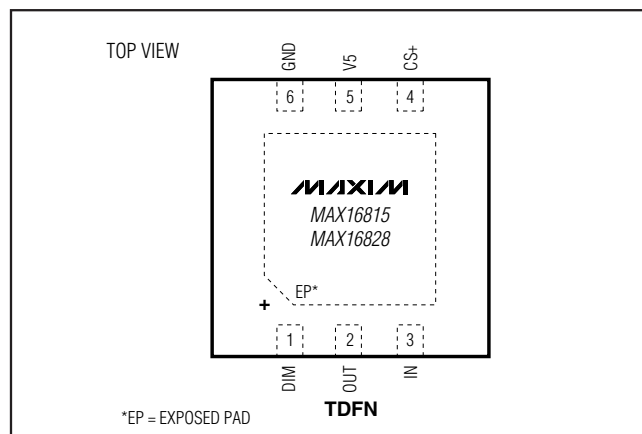

Features

- ◆ 6.5V to 40V Operating Range
- ◆ Adjustable LED Current
 - MAX16815: 35mA to 100mA
 - MAX16828: 35mA to 200mA
- ◆ $\pm 3.5\%$ LED Current Accuracy
- ◆ High-Voltage DIM Input for Dimming Interface
- ◆ Integrated Pass Element with Low-Dropout Voltage (0.4V typ)
- ◆ 5V Regulated Output with 4mA Source Capability
- ◆ Thermal Shutdown
- ◆ Output Short-Circuit Protection
- ◆ Available in Small, Thermally Enhanced, 3mm x 3mm, 6-Pin TDFN Package
- ◆ -40°C to +125°C Operating Temperature Range

Ordering Information

PART	PIN-PACKAGE	PKG CODE	TOP MARK
MAX16815ATT+T	6 TDFN-EP*	T633-2	ATI
MAX16828ATT+T	6 TDFN-EP*	T633-2	ATJ

Note: All devices are specified over the -40°C to +125°C operating temperature range.

+Denotes a lead-free package.

T = Tape and reel.

*EP = Exposed pad.

Simplified Diagram

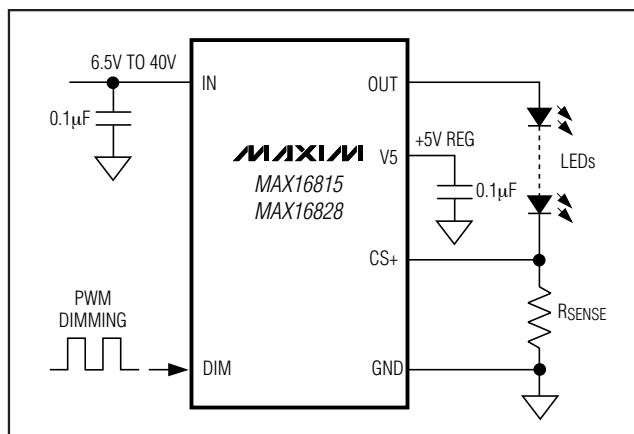

High-Voltage, 100mA/200mA Adjustable Linear High-Brightness LED Drivers with PWM Dimming

ABSOLUTE MAXIMUM RATINGS

IN to GND	-0.3V to +45V
CS+, V5 to GND	-0.3V to +6V
DIM to GND	-0.3V to (V _{IN} + 0.3V)
OUT Short Circuited to GND Duration (at V _{IN} = +16V)	60 minutes
Maximum Current into Any Pin (except IN and OUT).....	±20mA
Continuous Power Dissipation (T _A = +70°C) 6-Pin, 3mm x 3mm TDFN (derate 18.2mW/°C above +70°C).....	1454.5mW

Operating Temperature Range	-40°C to +125°C
Junction Temperature	+150°C
Junction to Case Thermal Resistance (θ _{JC}) (Note 1)	9°C/W
Junction to Ambient Thermal Resistance (θ _{JA}) (Note 1)	42°C/W
Storage Temperature Range	-60°C to +150°C
Lead Temperature (soldering, 10s)	+300°C

Note 1: Package thermal resistances obtained using the method described in JEDEC specification JESD51-7, using a four-layer board. For detailed information on package thermal considerations, see www.maxim-ic.com/thermal-tutorial.

Stresses beyond those listed under "Absolute Maximum Ratings" may cause permanent damage to the device. These are stress ratings only, and functional operation of the device at these or any other conditions beyond those indicated in the operational sections of the specifications is not implied. Exposure to absolute maximum rating conditions for extended periods may affect device reliability.

ELECTRICAL CHARACTERISTICS

(V_{IN} = 12V, C_{V5} = 0.1μF to GND, I_{V5} = 0, V_{DIM} = 4V, connect R_{SENSE} = 2Ω (MAX16815) and R_{SENSE} = 1Ω (MAX16828) between CS+ and GND. T_A = -40°C to +125°C, unless otherwise noted. Typical values are at T_A = +25°C.) (Note 2)

PARAMETER	SYMBOL	CONDITIONS	MIN	TYP	MAX	UNITS
Supply Voltage Range	V _{IN}	(Note 3)	6.5		40.0	V
Ground Current	I _G	I _{LOAD} = 100mA		0.82	2	mA
		I _{LOAD} = 200mA		1	2	
Guaranteed Output Current	I _{OUT}	R _{SENSE} = 2Ω (MAX16815)	100			mA
		R _{SENSE} = 1Ω (MAX16828)	200			
Output Current Accuracy		35mA < I _{OUT} < 100mA (MAX16815)		±3.5		%
		35mA < I _{OUT} < 200mA (MAX16828)		±3.5		
Dropout Voltage	ΔV _{DO}	I _{OUT} = 100mA (current pulsed), 12V < V _{IN} < 40V (MAX16815) (Note 4)		0.1	0.4	V
		I _{OUT} = 100mA (current pulsed), 6.5V < V _{IN} < 12V (MAX16815) (Note 4)		0.1	0.6	
		I _{OUT} = 200mA (current pulsed), 12V < V _{IN} < 40V (MAX16828) (Note 5)		0.27	0.55	
		I _{OUT} = 200mA (current pulsed), 6.5V < V _{IN} < 12V (MAX16828) (Note 5)		0.27	0.7	
Output Current Slew Rate		Current rising		9.7		mA/μs
		Current falling		9.7		
Short-Circuit Current		V _{OUT} = 0V, V _{IN} = 12V, MAX16815	130	200	270	mA
		V _{OUT} = 0V, V _{IN} = 12V, MAX16828	250	300	350	
CURRENT SENSE						
Regulated R _{SENSE} Voltage	V _{RSNS}		193	200	207	mV
DIM Input Current		V _{DIM} = 0V	-2.5	-1.0	-0.2	μA
DIM Input-Voltage High	V _{IH}		2.8			V
DIM Input-Voltage Low	V _{IL}				0.6	V
Turn-On Time	t _{ON}	After V _{DIM} rising to 4V (Note 7)			100	μs
Turn-Off Time	t _{OFF}	After V _{DIM} falling to 0.6V (Note 7)			55	μs

High-Voltage, 100mA/200mA Adjustable Linear High-Brightness LED Drivers with PWM Dimming

MAX16815/MAX16828

ELECTRICAL CHARACTERISTICS (continued)

($V_{IN} = 12V$, $C_{V5} = 0.1\mu F$ to GND, $I_{V5} = 0$, $V_{DIM} = 4V$, connect $R_{SENSE} = 2\Omega$ (MAX16815) and $R_{SENSE} = 1\Omega$ (MAX16828) between CS+ and GND. $T_A = -40^\circ C$ to $+125^\circ C$, unless otherwise noted. Typical values are at $T_A = +25^\circ C$.) (Note 2)

PARAMETER	SYMBOL	CONDITIONS	MIN	TYP	MAX	UNITS
THERMAL OVERLOAD						
Thermal-Shutdown Temperature				+159		$^\circ C$
Thermal-Shutdown Hysteresis				24		$^\circ C$
+5V REGULATOR						
Output-Voltage Load Regulation	V_{V5}	(Note 8)	4.8	5.0	5.2	V
Output Voltage	ΔV_{V5}	$0 < I_{V5} < 4mA$		12	20	mV/mA
V5 Short-Circuit Current		$V_{V5} = 0$ (Note 9)		15		mA

Note 2: All devices are 100% production tested at $T_A = +25^\circ C$. Limits over the operating temperature range are guaranteed by design.

Note 3: Resistors were added from OUT to CS+ to aid with power dissipation.

Note 4: Dropout is measured as follows:

Connect R_O from OUT to CS+. Connect $R_{SENSE} = 2\Omega$ (MAX16815) from CS+ to GND. Set $V_{IN} = 12V$ (record $V_{OUT1} = V_{OUT}$). For $V_{IN} = 40V$, use $R_O = 360\Omega$; for $V_{IN} = 6.5V$, use $R_O = 56\Omega$.

Reduce V_{IN} until $V_{OUT} = 0.97 \times V_{OUT1}$ (record as V_{IN2} and V_{OUT2}). $\Delta V_{DO} = V_{IN2} - V_{OUT2}$.

Note 5: Dropout is measured as follows:

Connect R_O from OUT to CS+. Connect $R_{SENSE} = 1\Omega$ (MAX16828) from CS+ to GND. Set $V_{IN} = 12V$ (record $V_{OUT1} = V_{OUT}$). For $V_{IN} = 40V$, use $R_O = 180\Omega$; for $V_{IN} = 6.5V$, use $R_O = 27\Omega$.

Reduce V_{IN} until $V_{OUT} = 0.97 \times V_{OUT1}$ (record as V_{IN2} and V_{OUT2}). $\Delta V_{DO} = V_{IN2} - V_{OUT2}$.

Note 6: $I_{V5} = 0mA$.

Note 7: t_{ON} time includes the delay and the rise time needed for I_{OUT} to reach 90% of its final value. t_{OFF} time is the time needed for I_{OUT} to drop below 10%. See the *Typical Operating Characteristics*. t_{ON} and t_{OFF} are tested with 100Ω (MAX16815) or 51Ω (MAX16828) from OUT to CS+.

Note 8: Current regulation varies with V5 load (see the *Typical Operating Characteristics*).

Note 9: Thermal shutdown does not function if V5 is shorted to ground.

High-Voltage, 100mA/200mA Adjustable Linear High-Brightness LED Drivers with PWM Dimming

Typical Operating Characteristics

($V_{IN} = 12V$, $T_A = +25^\circ C$, unless otherwise noted.)

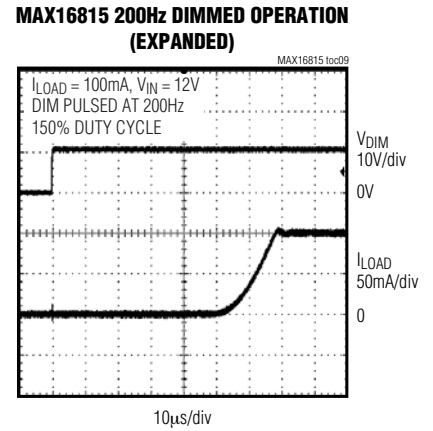
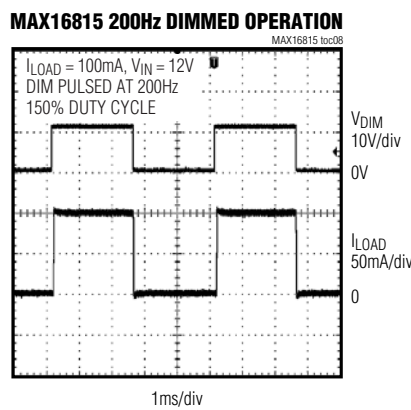
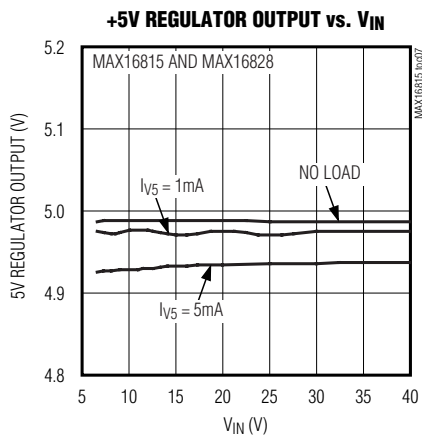
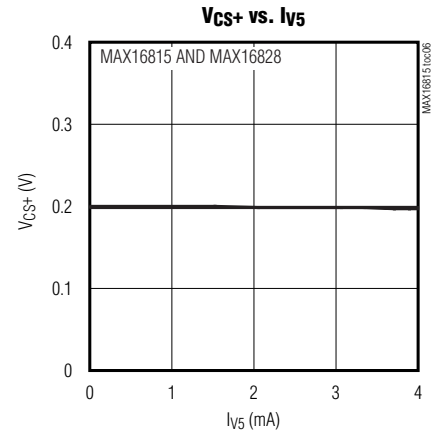
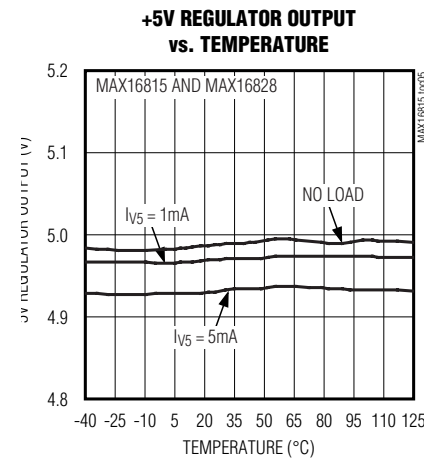
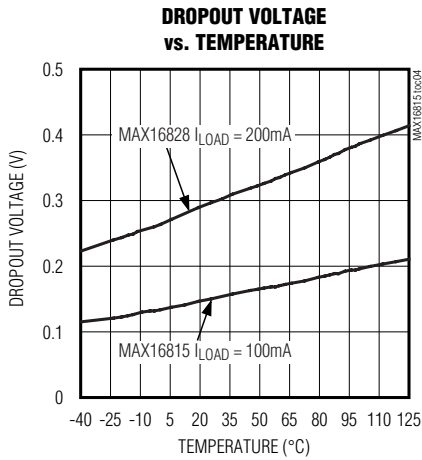
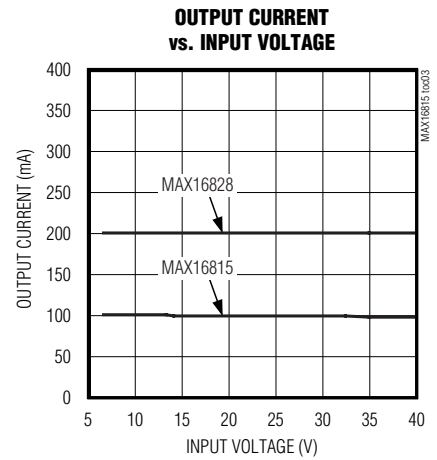
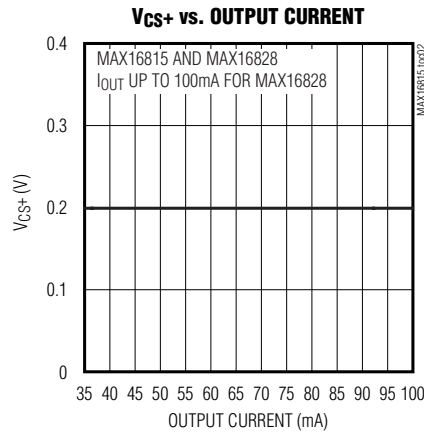
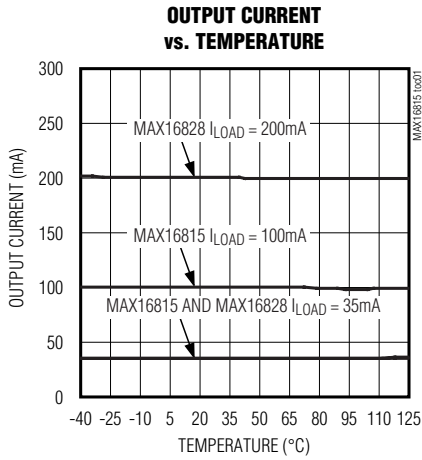

High-Voltage, 100mA/200mA Adjustable Linear High-Brightness LED Drivers with PWM Dimming

Typical Operating Characteristics (continued)

($V_{IN} = 12V$, $T_A = +25^\circ C$, unless otherwise noted.)

MAX16815 200Hz DIMMED OPERATION (EXPANDED)

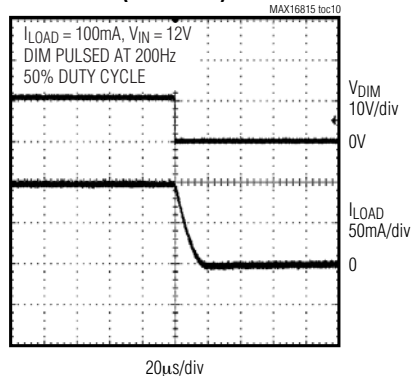

MAX16828 200Hz DIMMED OPERATION

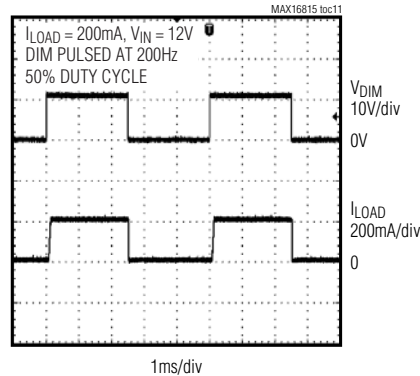

MAX16828 200Hz DIMMED OPERATION (EXPANDED)

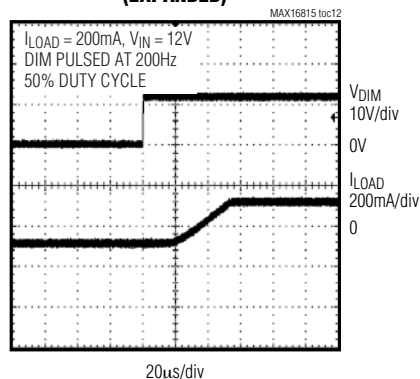

MAX16828 200Hz DIMMED OPERATION (EXPANDED)

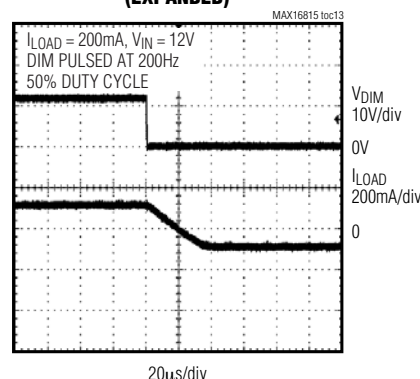

MAX16815/MAX16828

Pin Description

PIN	NAME	FUNCTION
1	DIM	Pulsed Dimming Input. Drive DIM low to turn off output current (LED current). Drive DIM high to turn on the output current (LED current). DIM is pulled high to V_{IN} when left unconnected.
2	OUT	Current-Regulated Output
3	IN	Positive Input Supply. Bypass IN with a 0.1µF (min) capacitor to GND.
4	CS+	LED Current-Sense Amplifier Input
5	V5	+5V Regulated Output. Connect a 0.1µF (min) capacitor from V5 to GND.
6	GND	Ground
—	EP	Exposed Pad. Connect to the ground plane for effective power dissipation. Do not use as the only ground connection.

High-Voltage, 100mA/200mA Adjustable Linear High-Brightness LED Drivers with PWM Dimming

Functional Diagram

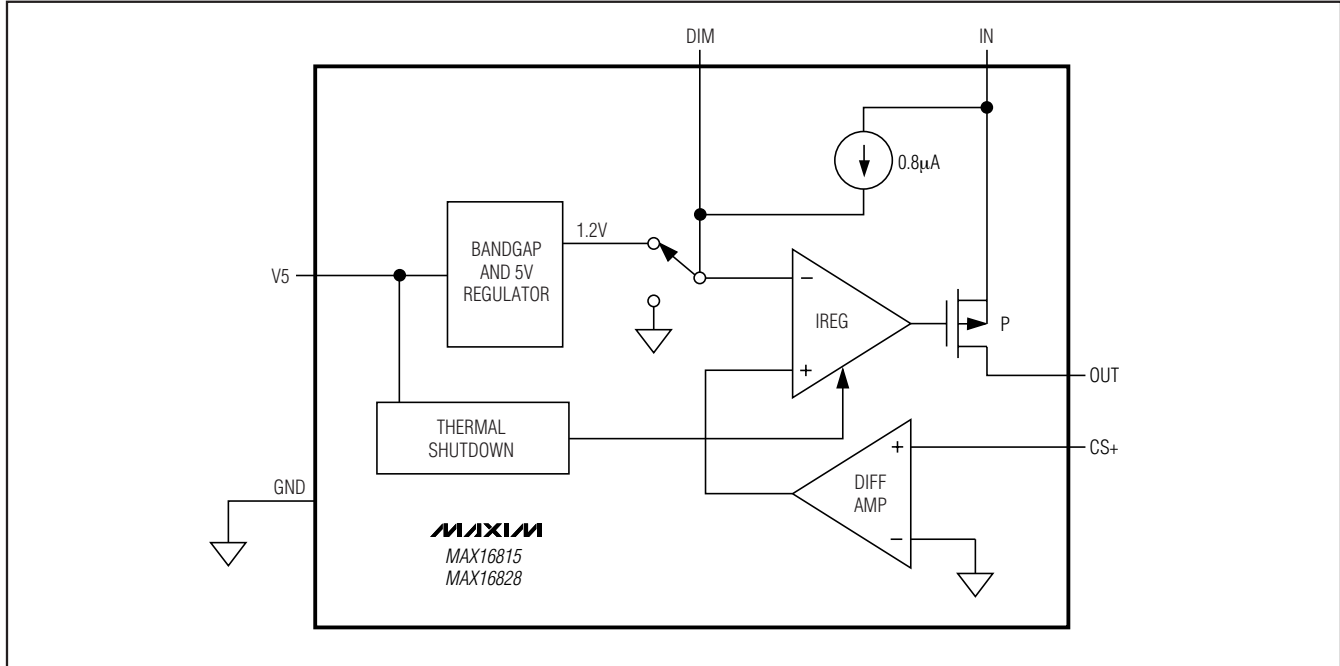

Detailed Description

+5V Regulator

The MAX16815/MAX16828 include a fixed +5V output regulator that delivers up to 4mA of load current throughout the 6.5V to 40V input voltage range. Connect a 0.1µF compensation capacitor from V5 to ground. Shorting V5 to ground disables the thermal shutdown. V5 stays on during PWM dimming.

Thermal Protection

The MAX16815/MAX16828 enter a thermal-shutdown mode in the event of overheating. This typically occurs in overload or output short-circuit conditions. If the junction temperature exceeds $T_J = +159^{\circ}\text{C}$ (typ), the internal thermal-protection circuitry turns off the series pass device. The MAX16815/MAX16828 recover from thermal-shutdown mode once the junction temperature drops by 24°C (typ). The devices therefore protect themselves by thermal cycling in the event of a short-circuit or overload condition. Shorting V5 to ground disables the thermal shutdown.

Applications Information

Programming the LED Current

The MAX16815/MAX16828 use a sense resistor across CS+ and GND to set the LED current. The LED current is given by $I_{LED} = V_{RSNS}/R_{SENSE}$.

Input-Voltage Considerations

For proper operation, the minimum input voltage must always be:

$$V_{IN(MIN)} \geq V_{RSNS(MAX)} + V_{FT(MAX)} + \Delta V_{DO(MAX)}$$

where $V_{FT(MAX)}$ is the total forward voltage of all series connected LEDs. The minimum operating voltage of the device is +6.5V. The device operates below +6.5V; however, output current may not meet the full regulation specification (see the *Typical Operating Characteristics*) and the V5 regulator will drop below 5V.

Low-Frequency PWM Dimming at the Output

Provide a pulse to the dimming input (DIM) of the MAX16815/MAX16828 to produce a PWM output. Alternatively, connect DIM to IN and pulse IN.

High-Voltage, 100mA/200mA Adjustable Linear High-Brightness LED Drivers with PWM Dimming

MAX16815/MAX16828

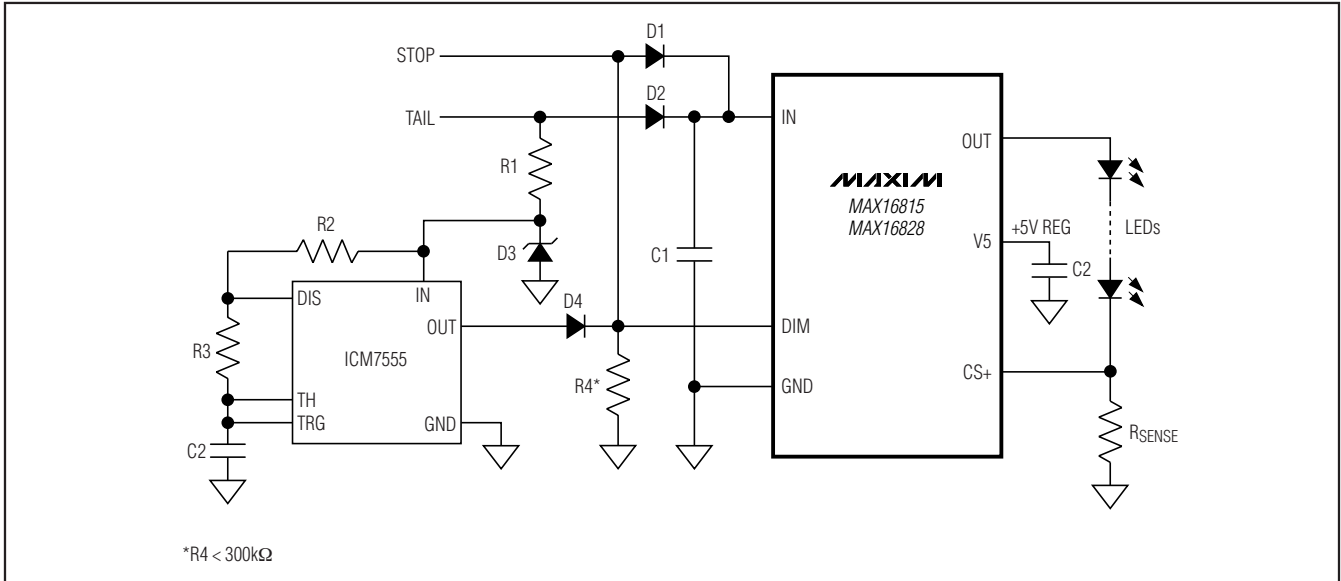

Figure 1. PWM Dimming Operation with ICM7555 Timer

Two Brightness Levels for TAIL/STOP Lights

Figure 1 shows PWM dimming operation for the MAX16815/MAX16828 with an ICM7555 timer. The ICM7555 provides adjustable duty cycle using two external resistors and a capacitor. In TAIL operation, the output of the ICM7555 feeds into DIM and lights up the LEDs. The LED's brightness depends on the duty cycle of the ICM7555. When V_{STOP} is present, DIM is pulled up to V_{STOP} . The PWM dimming operation is disabled and the LEDs light up to full brightness. See the ICM7555 data sheet for formulas to calculate the dimming frequency and the duty cycle.

LED Current Thermal Foldback

With a minimum number of external components, the MAX16815/MAX16828 provide LED current thermal foldback using a negative temperature coefficient (NTC) thermistor. Figure 2 shows a thermistor connected to V5 and the CS+ of the MAX16815/MAX16828. As the temperature increases, the voltage drop across R2 increases, causing the LED current to decrease.

$$I_{LED} = [V_{RSNS} - (R_2 / R_T) (V_{V5} - V_{RSNS})] / R_1$$

Other Applications

The application circuit in Figure 3 implements a two-level brightness current for TAIL/STOP lights. In TAIL operation, Q1 is off and R1 sets the output current. In

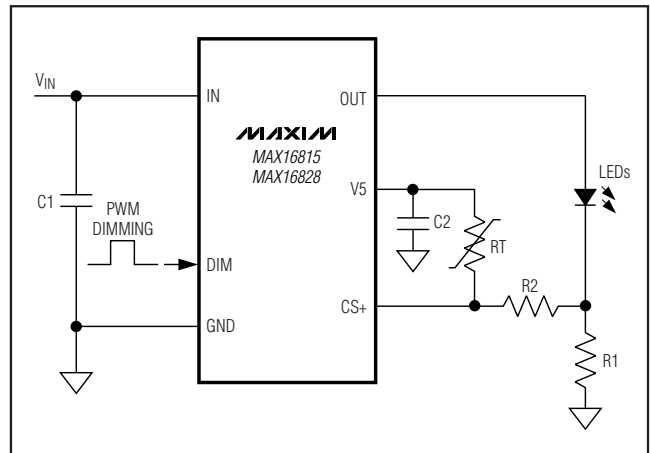

Figure 2. LED Current Thermal Foldback with an NTC Thermistor

STOP operation, Q1 turns on and the output current is set by a parallel combination of R1 and R2. Figure 4 shows an application circuit with the MAX16815/MAX16828 using a single BJT to provide high output current. For proper operation:

$$V_{IN(MIN)} > V_{CESAT(MAX)} + V_{FT(MAX)} + V_{RSNS}$$

where $V_{CESAT(MAX)}$ is the maximum saturation voltage of the external BJT and $V_{FT(MAX)}$ is the total forward voltage of all series connected LEDs.

High-Voltage, 100mA/200mA Adjustable Linear High-Brightness LED Drivers with PWM Dimming

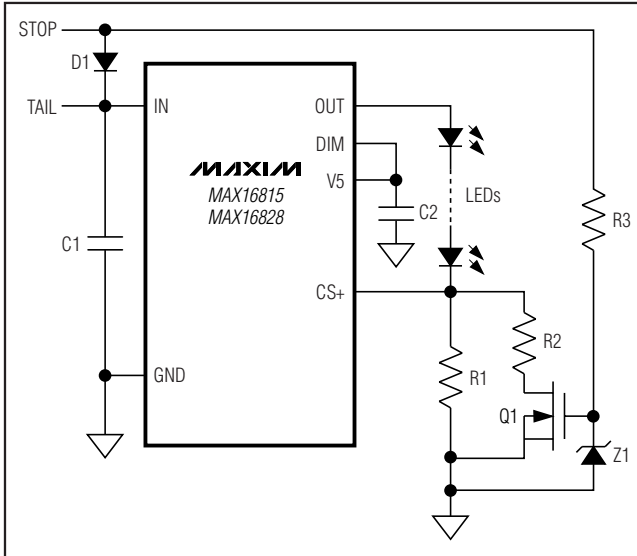

Figure 3. Two-Level Brightness with Current Level Switch for TAIL/STOP Lights

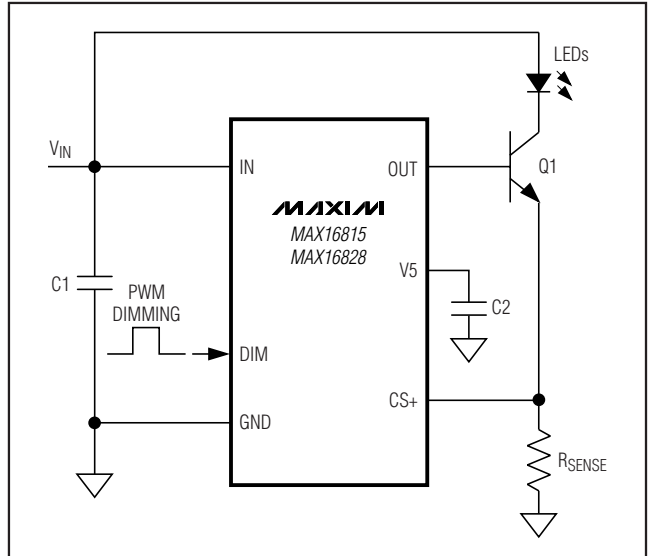

Figure 4. Increased LED Current (Ampere Range) with a Single BJT

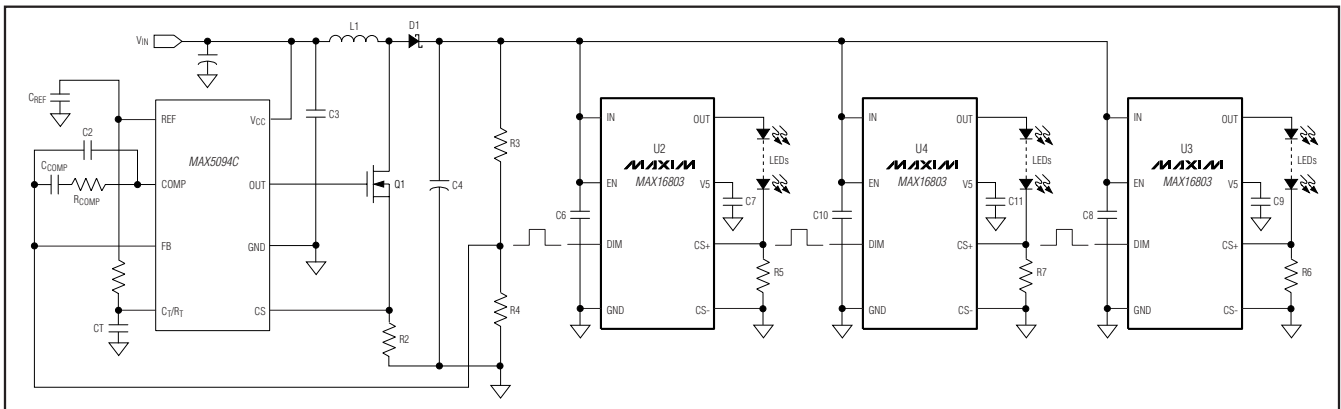
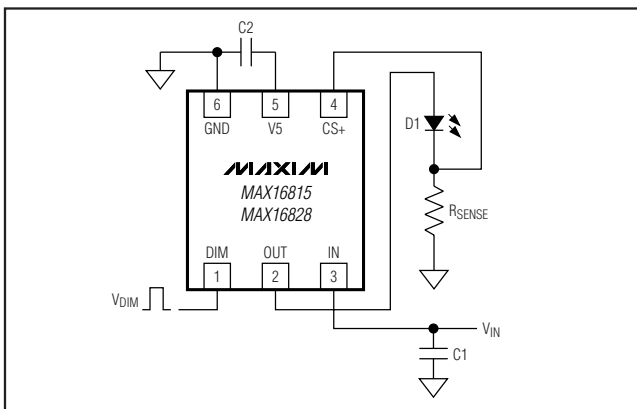

Figure 5. Multichannel HB LED Drivers for LCD Backlight

Typical Operating Circuit



Multichannel HB LED Driver

Figure 5 shows an array of MAX16815/MAX16828s with independent DIM control. The MAX5094C, a current-mode PWM controller, provides the input power to each LED driver preregulated voltage to multiple MAX16815/MAX16828 drivers.

Chip Information

PROCESS: BiCMOS

High-Voltage, 100mA/200mA Adjustable Linear High-Brightness LED Drivers with PWM Dimming

Package Information

(The package drawing(s) in this data sheet may not reflect the most current specifications. For the latest package outline information go to www.maxim-ic.com/packages.)

MAX16815/MAX16828

6, 8, & 10L, DFN THIN.EPS

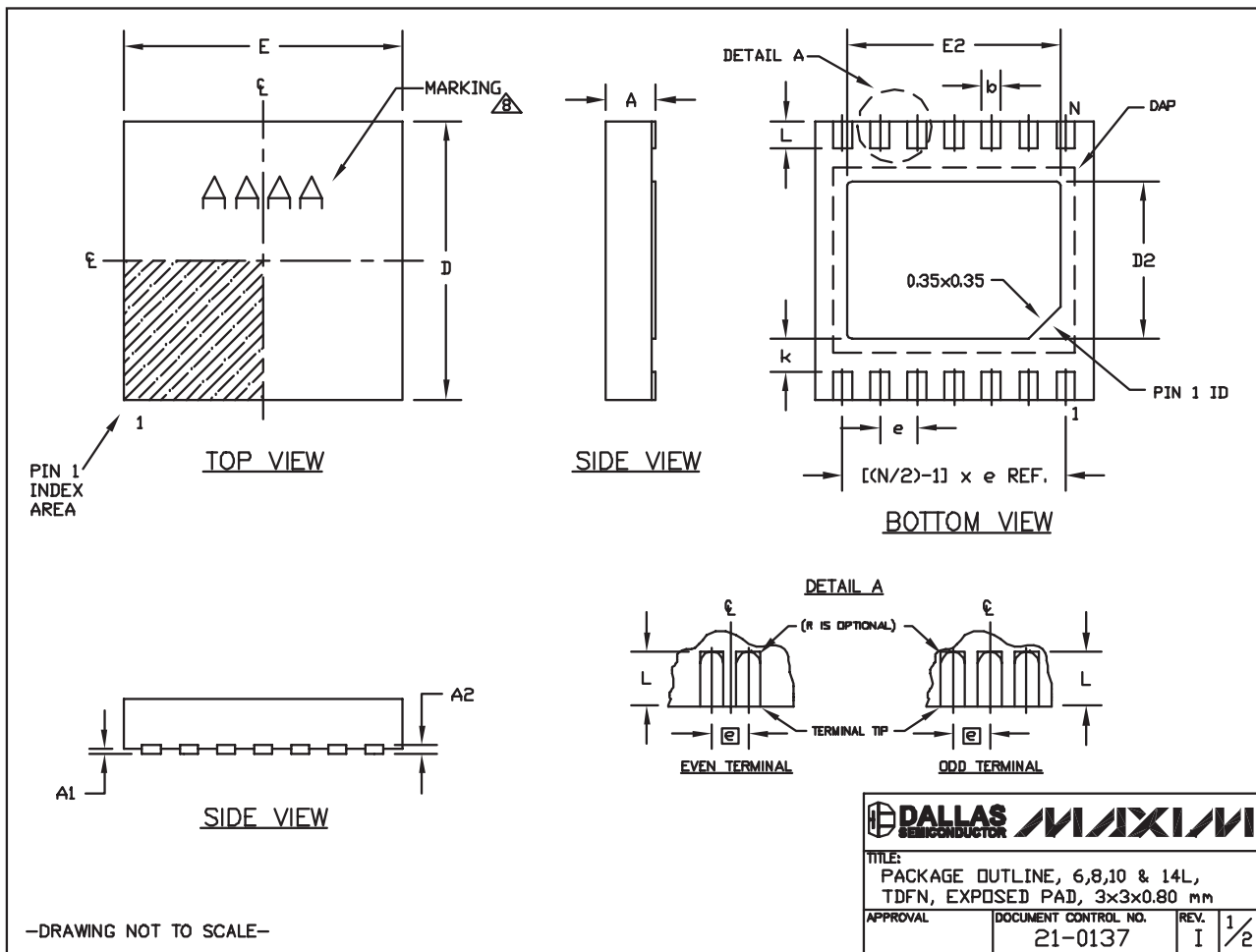

High-Voltage, 100mA/200mA Adjustable Linear High-Brightness LED Drivers with PWM Dimming

Package Information (continued)

(The package drawing(s) in this data sheet may not reflect the most current specifications. For the latest package outline information go to www.maxim-ic.com/packages.)

COMMON DIMENSIONS		
SYMBOL	MIN.	MAX.
A	0.70	0.80
D	2.90	3.10
E	2.90	3.10
A1	0.00	0.05
L	0.20	0.40
k	0.25 MIN.	
A2	0.20 REF.	

PACKAGE VARIATIONS								
PKG. CODE	N	D2	E2	e	JEDEC SPEC	b	[(N/2)-1] x e	
T633-2	6	1.50±0.10	2.30±0.10	0.95 BSC	MO229 / WEEA	0.40±0.05	1.90 REF	
T833-2	8	1.50±0.10	2.30±0.10	0.65 BSC	MO229 / WEEC	0.30±0.05	1.95 REF	
T833-3	8	1.50±0.10	2.30±0.10	0.65 BSC	MO229 / WEEC	0.30±0.05	1.95 REF	
T1033-1	10	1.50±0.10	2.30±0.10	0.50 BSC	MO229 / WEED-3	0.25±0.05	2.00 REF	
T1033-2	10	1.50±0.10	2.30±0.10	0.50 BSC	MO229 / WEED-3	0.25±0.05	2.00 REF	
T1433-1	14	1.70±0.10	2.30±0.10	0.40 BSC	---	0.20±0.05	2.40 REF	
T1433-2	14	1.70±0.10	2.30±0.10	0.40 BSC	---	0.20±0.05	2.40 REF	

NOTES:

1. ALL DIMENSIONS ARE IN mm. ANGLES IN DEGREES.
2. COPLANARITY SHALL NOT EXCEED 0.08 mm.
3. WARPAGE SHALL NOT EXCEED 0.10 mm.
4. PACKAGE LENGTH/PACKAGE WIDTH ARE CONSIDERED AS SPECIAL CHARACTERISTIC(S).
5. DRAWING CONFORMS TO JEDEC MO229, EXCEPT DIMENSIONS "D2" AND "E2", AND T1433-1 & T1433-2.
6. "N" IS THE TOTAL NUMBER OF LEADS.
7. NUMBER OF LEADS SHOWN ARE FOR REFERENCE ONLY.
8. MARKING IS FOR PACKAGE ORIENTATION REFERENCE ONLY.

—DRAWING NOT TO SCALE—

		
TITLE: PACKAGE OUTLINE, 6,8,10 & 14L, TDFN, EXPOSED PAD, 3x3x0.80 mm		
APPROVAL	DOCUMENT CONTROL NO. 21-0137	REV. I 2/2

Maxim cannot assume responsibility for use of any circuitry other than circuitry entirely embodied in a Maxim product. No circuit patent licenses are implied. Maxim reserves the right to change the circuitry and specifications without notice at any time.

10 **Maxim Integrated Products, 120 San Gabriel Drive, Sunnyvale, CA 94086 408-737-7600**