

LED driving

LEDs

A LED (LED = Light Emitting Diode) emits light (photons) when a current flows from P- to N-material. The light is created through recombination of charge carriers in the PN transitions. The emitted light has a quite well defined but in some cases temperature dependent spectrum. Semiconductor materials are mostly substances from group III and V, although some also come from II and IV groups, in the periodic system. These substrates are therefore named III-V or II-IV-materials. The most common materials and their color (light wavelength) is:

- Gallium Arsenide (GaAs) giving infrared to red light (650 nm)
- Gallium Arsenide Phosphide (GaAsP) giving red to yellow light (630-590 nm)
- Gallium Phosphide (GaP) giving green to blue green light (565 nm)
- Gallium Nitride (GaN) giving blue light (430nm)
- Indium Gallium Nitride (InGaN) giving deep blue to ultraviolet light (390 – 360 nm)

LEDs emitting blue – deep blue light are supplied with a half transparent phosphorescent layer, usually yellow phosphorescence to create white LEDs.

Due to the greater insensitivity of blue (GaN) LEDs to temperature variations sometimes red LEDs are created out of blue or ultraviolet LEDs crystals by covering the chip with a non transparent layer of red phosphorescent material.

The LED is activated by applying a forward voltage. The amount of light is determined by controlling the current. The current is almost directly proportional to the number of generated photons.

The forward voltage is about 1.4 – 2V for GaAs, 2 – 2.5 for GaAsP, 3 - 3.5 for GaP and 3.8 – 4.5 for InGaN (blue or white LEDs)

LEDs can also be connected in series on a substrate or in a package; this can give other existing forward voltages for the LEDs as a module component.

Current limiting of the LED using resistor

When the available supply voltage is higher than the forward voltage of the LED and held constant, a resistor can be used to limit the current. For small currents and stable voltages this is one possible biasing method. Typical examples are LEDs as instrumentation lights, indicators and decorative light.

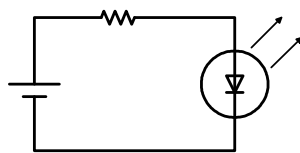

Red, yellow, green and blue LEDs have a very high efficiency (80-90% for red) and give a single colored light without using a color filter as is normal for colored light from incandescent light bulbs. Normal bulbs have an efficiency of about 10%. When you apply a color filter to remove all other color than red wavelengths from the white light, you will get a resulting efficiency of about 1%.

It is about 100 times difference in efficiency for as an example a red LED in a tail light for vehicle in relation to incandescent light bulb in the same application. A 10W Incandescent light bulb in a tail light is comprehensive to a 0.1W red LED. When the forward voltage is about 2.2V it gives $0.1W / 2.2V \approx 0,045A = 45mA$. An electrical system for an automotive vehicle has a nominal voltage of 13.8V and a red LED about 2.2V forward voltage. This

gives a resistance value of $11.6V / 0.045A \approx 258\Omega (\approx 270\Omega / 1W)$ as current limiter. The resistor must handle a loss of $11.6V \times 0.045A \approx 0.52 W$. The total power consumption is $13.8V \times 0.05A = 0.62 W$ and electric efficiency $0.1W/0.62W \approx 0.16$.

Even if 16% is a low efficiency for the electrical conversion when you only use a resistor, the total consumption of 0.6W is over 10 times better than a 10W incandescent light bulb.

You can improve the efficiency by putting the LEDs in series. 3 of 2.2V in series give 6.6V forward voltage, example:

LED current for 0.1W effect; $0.1 / 6.6 \approx 0.015A = 15mA$
 Power loss; $7.2V \times 0.015A \approx 0.11W$
 Resistance; $7.2V / 0.015A \approx 480\Omega (\approx 470\Omega / 0.25W)$
 Electric efficiency; $0.1W / 0.21W \approx 0.48 = 48\%$

Current control of LED using linear regulator

You can not take for granted in many applications and especially in automotive electronics that you will always have a stable and regulated power supply. The operational span for a typical automotive battery is at least 9-16V and shall also accommodate double the supply voltage for at least 5 minutes (27.2V). With a resistor as a current limiter you get quite a large variation of the current.

According to earlier example, 13.8V, 45mA:
 $9V \Rightarrow (9V - 2.2V) / 270\Omega \approx 25mA (-45\%)$
 $16V \Rightarrow (16V - 2.2V) / 270\Omega \approx 51mA (+13\%)$
 $27.2V \Rightarrow (27.2V - 2.2V) / 270\Omega \approx 93mA (+206\%)$

The LED has to survive 93mA and shine with approved strength in the interval 25 – 93 mA. Putting more LEDs in series makes the demand on the LED higher and the result is worse when varying the supply voltage. According to the earlier example, 13.8V, 15mA (three diodes i series):
 $9V \Rightarrow (9V - 6.6) / 470\Omega \approx 0.5mA (-97\%)$, (30 times weaker than intended.)
 $16V \Rightarrow (16V - 6.6V) / 470\Omega \approx 20mA (+33\%)$
 $27.2V \Rightarrow (27.2V - 6.6V) / 470\Omega \approx 44mA (+293\%)$

A solution is to introduce active current limiting according to figure:

D1 should be a Zener diode or a voltage reference. The current is defined by equation: $I_{LED} = V_{D1}/R_{SET}$
 D2 gives simple temperature compensation in relation to the transistor base diode.

However there still remains the problem of energy loss and overheating that will be more severe the brighter the LED you use.

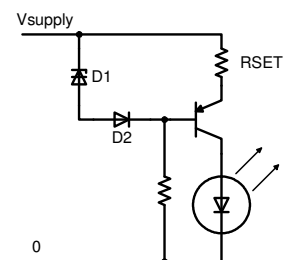

Switch current supply for LEDs

In most cases using a switch regulator will give you a better electrical solution. Efficiency can be better than 80% and most cases better than 90% should be achievable.

Buck regulator

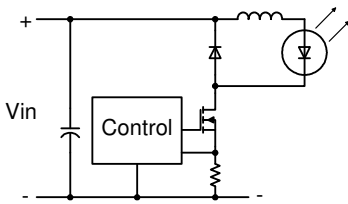

The simplest switch regulator is the buck regulator. It replaces directly the earlier described linear (drop) regulator. Using a control circuit, like the MLX10803 from Melexis, and controlling a transistor on or off. The voltage difference between input voltage and the needed LED voltage is stored in a coil. The more energy stored in the coil the lower will the resistance be from the coil to let current through and the amount of current increases. When the current reaches a defined value it changes the control circuit and the transistor state changes from on to off.

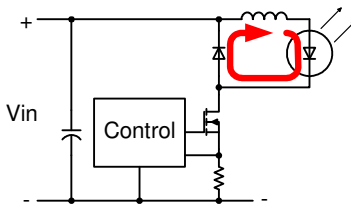

The coil allows discharging during a defined time in form of a current thru the LED. This current starts from the same level as the current that was passing thru the transistor before the change for on to off. The result is an alternating current over the LED. The average value of the current is controlled by the switch regulator circuit. This value can be set by programming the regulator IC or by external components. Melexis uses both methods for their LED drivers. The current is also defined by the selection of a sense resistor on the drain side on the switch NFET.

The resulting current over the LED is continuous but alternating. The current consumption is in contrast discontinuous, see figure

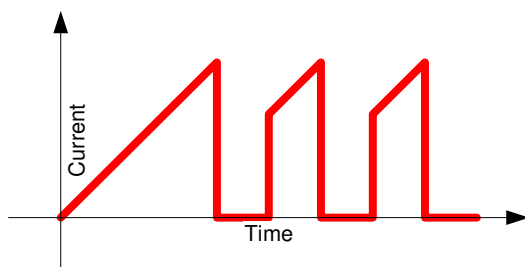

Boost regulator

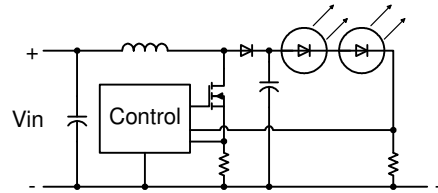

If the supply voltage is lower than the sum of forward voltages for all LEDs in series a Boost regulator is needed. A boost regulator is more complicated when it also needs to control the voltage in addition to controlling current.

This type of boost regulator can not handle the case when the supply voltage is higher than the sum on the forward voltage of all the LEDs in series. The current will then rush uncontrolled as seen in figure below.

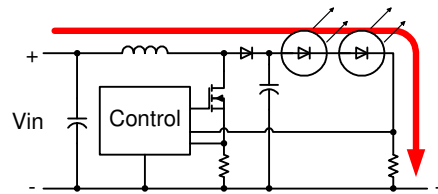

Sepic regulator

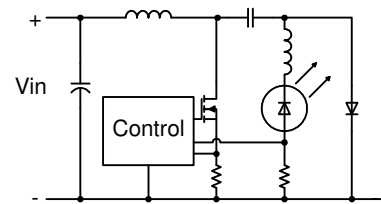

This type of regulator can work as both boost regulator and buck regulator. The weak spot is the capacitance between the coils. That capacitor must handle all the energy that is converted to suitable current and voltage for the LED.

This type of regulator is useful when over voltage can exist on the supply line and you primarily need a boost regulator.

Boost/Buck regulator

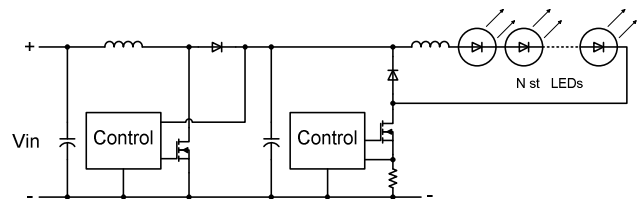

The most stable and safest solution for a good boost LED driver is to combine a boost regulator with a buck regulator by just connecting them in cascade. This creates the minimal problem in optimization and electrical noise. One boost regulator can also preferably deliver the voltage for several buck regulators in parallel.

**The influence of supply voltage
(Buck regulator)**

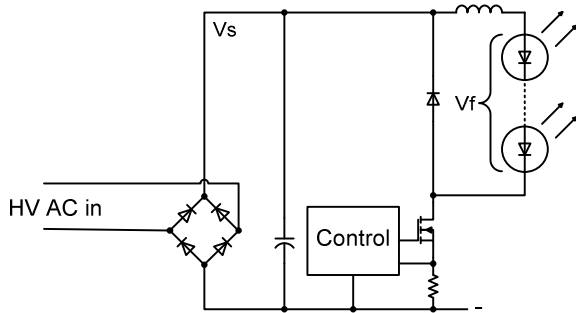

$V_f \approx V_{supply} > V_f$

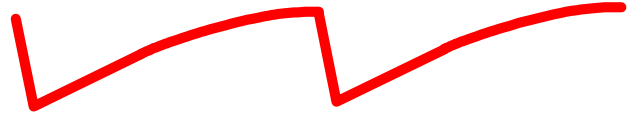

If the supply voltage is low in relation to LED forward voltage there is also a problem, even if the switching frequency will automatically become low.

Most switching LED drivers can come into this state when the resulting LED forward voltage became higher than intended, or the supply voltage lower.

The Melexis LED driver MLX10803 has an elegant solution on this problem.

$V_{supply} \gg V_f$

Having a very high supply voltage and a forward voltage drop (V_f) over the LED 10-20 times lower, a problem arises because of a very fast charge time of the coil in series with the LED. Fast charge (and discharge) events are connected with bad efficiency.

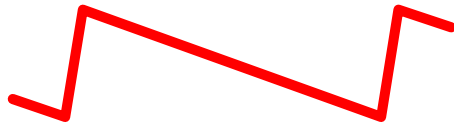

The charge and discharge cycle runs according to the figure and it is simple to see that the rise time is equal to 10 – 20 times higher frequency than the base frequency for the regulation.

A good solution for good efficiency and low level on emitted electrical noise is to select a switch frequency that gives a rise time that equals the frequency of the coil specification. In the case of 10 – 20 times voltage difference you should choose a switching frequency that is 10-20 times lower than the coils maximal efficiency frequency.

V_{supply} isolation

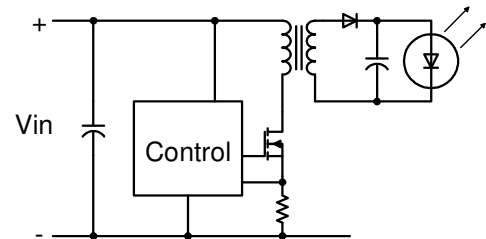

It is also possible to use the coil as a transformer in many different ways. The advantage is that you can have a very large independence with respect to the supply voltage, and high isolation between supply voltages and LED current. A bit more complicated is to also isolate the regulation feedback from the controller circuit.

It is easy using MLX10803 from Melexis to create an optical feedback loop for a stable and constant light for the LED applications.

$V_{supply} \approx 2V_f$

If the supply voltage is double the sum of the LEDs forward voltages in series, you will have the most optimal solution.

The regulated current then has this look:



Electrical noise from switch regulators

All switching regulators generate electrical noise. Common DC/DC voltage regulators working with a voltage level control can often deliver a well filtered supply voltage. This is mostly achieved by a large capacitor on the output and gain improvement by high switching frequency. LED regulators should use current regulation and not voltage regulation. A large capacitor creates then a slow reaction to voltage changes and prevents the regulator from keeping the current independent of the voltage.

A simple and cost efficient current regulator is the earlier mentioned buck regulator, but it can generate strong electrical noise in a LED application if it is poorly dimensioned. Circuit board layout and cables have a vital importance.

Thumb rules for low noise:

- Low switching frequency
- Short cables and a small current loop to the LEDs.
- Fast feedback diode.
- Switching transistor on the center of the circuit board.
- Careful with cable and noise filter on the supply line.

MLX10801 and MLX10803 also employ a pseudo random generator on the switching frequency to minimize electrical noise. For more information about low noise applications contact Melexis (<http://www.melexis.com>).

Simple and robust example

Below is an example of a minimal and inexpensive LED driver from Melexis. The circuit can simply be connected to microcontrollers in several ways.

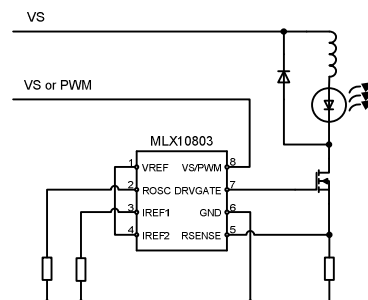

Below, one other example how in a simple way to implement slow up and down dimming effect of the LED(s).

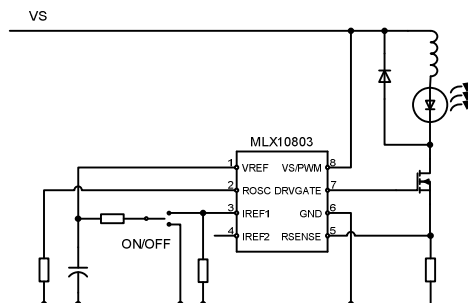

More information about how to drive LEDs and useful IC circuits can be found at: <http://www.melexis.com>

For the latest version of this document, go to our website at www.melexis.com

Or for additional information contact Melexis Direct:

Europe, Africa, Asia:	America:
Phone: +32 1367 0495	Phone: +1 603 223 2362
E-mail: sales_europe@melexis.com	E-mail: sales_usa@melexis.com

ISO/TS 16949 and ISO14001 Certified