

LP3954

Advanced Lighting Management Unit

General Description

LP3954 is an advanced lighting management unit for handheld devices. It drives any phone lights including display backlights, RGB, keypad and camera flash LEDs. The boost DC-DC converter drives high current loads with high efficiency. White LED backlight drivers are high efficiency low voltage structures with excellent matching and automatic fade in/ fade out function. The new stand-alone command based RGB controller is feature rich and easy to configure. Built-in audio synchronization feature allows user to synchronize the color LEDs to audio input. Integrated high current driver can drive camera flash LED or motor/vibra. Internal ADC can be used for ambient light or temperature sensing. The flexible SPI/I²C interface allows easy control of LP3954. Small micro SMD package together with minimum number of external components is a best fit for handheld devices.

Features

- Audio synchronization for color/RGB LEDs
- Command based PWM controlled RGB LED drivers
- High current driver for flash LED with built-in timing.
- 4+2 or 6 low voltage constant current white LED drivers with programmable 8-bit adjustment (0...25mA/LED)
- High efficiency Boost DC-DC converter
- SPI / I²C compatible interface
- Possibility for external PWM dimming control
- Possibility for clock synchronization for RGB timing
- Ambient light and temperature sensing possibility
- Small package – micro SMD or micro SMDxt, 3.0 x 3.0 x 0.6mm

Applications

- Cellular Phones
- PDAs, MP3 players

Typical Applications

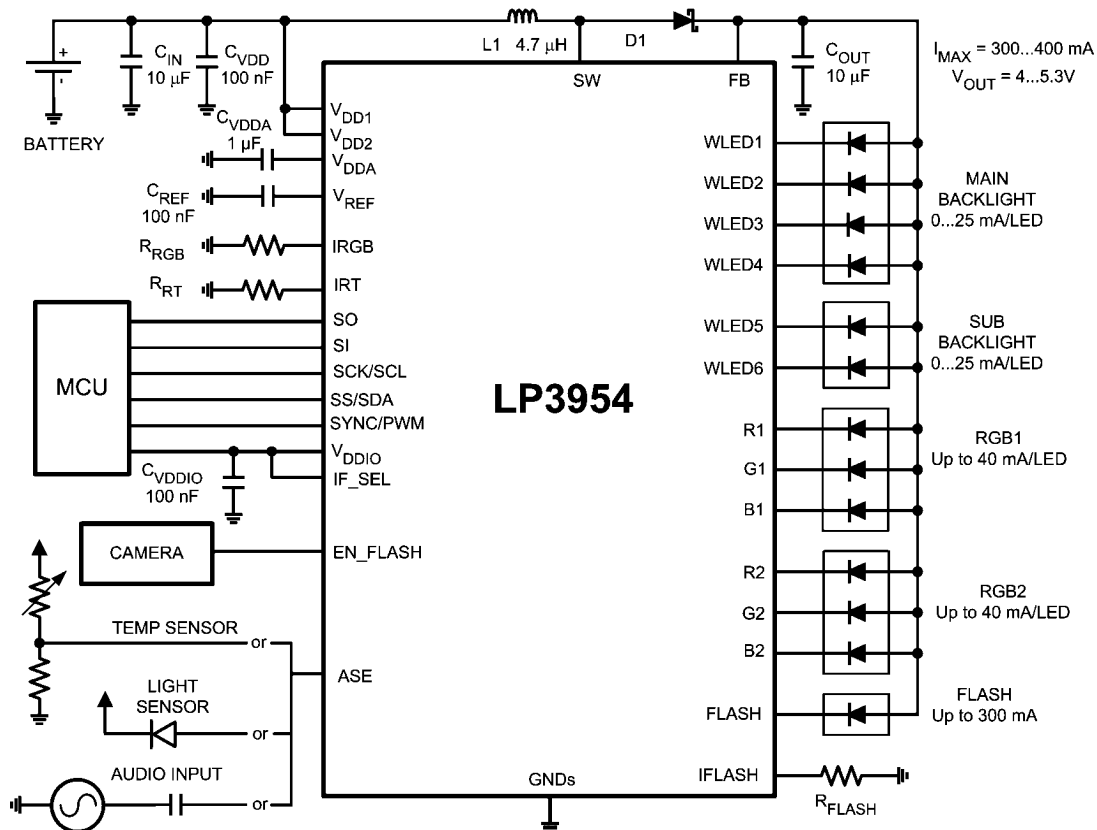

20132260

Connection Diagrams and Package Mark Information

CONNECTION DIAGRAMS

Micro SMD Package, 3.0 x 3.0 x 0.6mm, 0.5mm pitch NS Package Number TLA36AAA or
 Micro SMDxt Package, 3.0 x 3.0 x 0.65mm, 0.5mm pitch NS Package Number RLA36AAA

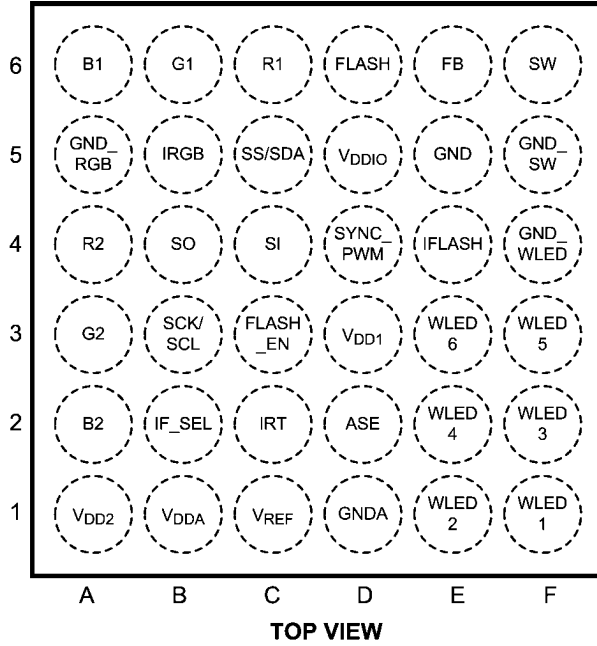

20132203

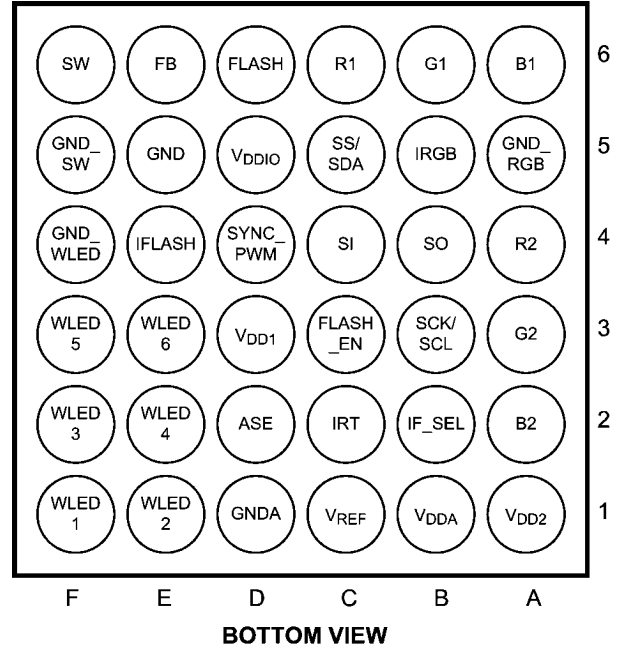

20132204

PACKAGE MARK



XY = 2 Digit Date Code
 TT = Die Traceability
 D49B = Product Identification
 ◊ = Pin 1A

20132205

ORDERING INFORMATION

Order Number	Package Marking	Supplied As	Spec/Flow
LP3954TL	D49B	TNR 250	NoPB
LP3954TLX	D49B	TNR 1000	NoPB
LP3954RL	D49B	TNR 250	NoPB
LP3954RLX	D49B	TNR 1000	NoPB

PIN DESCRIPTIONS

Pin #	Name	Type	Description
6F	SW	Output	Boost Converter Power Switch
6E	FB	Input	Boost Converter Feedback
6D	FLASH	Output	High Current Flash Output
6C	R1	Output	Red LED 1 Output
6B	G1	Output	Green LED 1 Output
6A	B1	Output	Blue LED 1 Output
5F	GND_SW	Ground	Power Switch Ground
5E	GND	Ground	Ground
5D	VDDIO	Power	Supply Voltage for Input/output Buffers and Drivers
5C	SS/SDA	Logic Input/Output	Slave Select (SPI), Serial Data In/Out (I ² C)
5B	IRGB	Input	Bias Current Set Resistor for RGB Drivers
5A	GND_RGB	Ground	Ground for RGB Currents
4F	GND_WLED	Ground	Ground for WLED Currents
4E	IFLASH	Input	High Current Flash Current Set Resistor
4D	SYNC_PWM	Logic Input	External PWM Control for LEDs or External Clock for RGB Sync
4C	SI	Logic Input	Serial Input (SPI), Address Select (I ² C)
4B	SO	Logic Output	Serial Data Out (SPI)
4A	R2	Output	Red LED 2 output
3F	WLED5	Output	White LED 5 output
3E	WLED6	Output	White LED 6 output
3D	VDD1	Power	Supply voltage
3C	EN_FLASH	Logic Input	Enable for High Current Flash
3B	SCK/SCL	Logic Input	Clock (SPI/I ² C)
3A	G2	Output	Green LED 2 Output
2F	WLED3	Output	White LED 3 output
2E	WLED4	Output	White LED 4 output
2D	ASE	Input	Audio Synchronization Input
2C	IRT	Input	Oscillator Frequency Resistor
2B	IF_SEL	Logic Input	Interface (SPI or I ² C compatible) Selection (IF_SEL = 1 for SPI)
2A	B2	Output	Blue LED 2 Output
1F	WLED1	Output	White LED 1 Output
1E	WLED2	Output	White LED 2 Output
1D	GND A	Ground	Ground for Analog Circuitry
1C	VREF	Output	Reference Voltage
1B	VDDA	Power	Internal LDO Output
1A	VDD2	Power	Supply Voltage

Absolute Maximum Ratings (Notes 1, 2)

If Military/Aerospace specified devices are required, please contact the National Semiconductor Sales Office/Distributors for availability and specifications.

V (SW, FB, R1-2, G1-2, B1-2, FLASH, WLED1-6)(Notes 3, 4)	-0.3V to +7.2V
V_{DD1} , V_{DD2} , V_{DD_IO} , V_{DDA}	-0.3V to +6.0V
Voltage on ASE, IRT, IFLASH, IRGB, VREF	-0.3V to $V_{DD1}+0.3V$ with 6.0V max
Voltage on Logic Pins	-0.3V to $V_{DD_IO}+0.3V$ with 6.0V max
V(all other pins): Voltage to GND	-0.3V to 6.0V
$I(V_{REF})$	10 μ A
I(R1, G1, B1, R2, G2, B2)	100mA
I(FLASH)(Note 5)	400mA
Continuous Power Dissipation (Note 6)	Internally Limited
Junction Temperature (T_{J-MAX})	150°C
Storage Temperature Range	-65°C to +150°C
Maximum Lead Temperature (Soldering) (Note 7)	260°C
ESD Rating (Note 8)	
Human Body Model:	2kV

Operating Ratings (Notes 1, 2)

V (SW, FB, WLED1-6, R1-2, G1-2, B1-2, FLASH)	0 to 6.0V
$V_{DD1,2}$ with external LDO	2.7 to 5.5V
$V_{DD1,2}$ with internal LDO	3.0 to 5.5V
V_{DDA}	2.7 to 2.9V
V_{DD_IO}	1.65V to V_{DD1}
Voltage on ASE	0.1V to $V_{DDA}-0.1V$
Recommended Load Current	0mA to 300mA
Junction Temperature (T_J) Range	-30°C to +125°C
Ambient Temperature (T_A) Range (Note 9)	-30°C to +85°C

Thermal Properties

Junction-to-Ambient Thermal Resistance(θ_{JA}), TLA36AAA or RLA36AAA Package (Note 10)	60°C/W
---	--------

Electrical Characteristics (Notes 2, 11)

Limits in standard typeface are for $T_J = 25^\circ\text{C}$. Limits in **boldface** type apply over the operating ambient temperature range ($-30^\circ\text{C} < T_A < +85^\circ\text{C}$). Unless otherwise noted, specifications apply to the LP3954 Block Diagram with: $V_{DD1} = V_{DD2} = 3.6\text{V}$, $V_{DDIO} = 2.8\text{V}$, $C_{VDD} = C_{VDDIO} = 100\text{nF}$, $C_{OUT} = C_{IN} = 10\mu\text{F}$, $C_{VDDA} = 1\mu\text{F}$, $C_{REF} = 100\text{nF}$, $L_1 = 4.7\mu\text{H}$, $R_{FLASH} = 1.2\text{k}$, $R_{RGB} = 5.6\text{k}$ and $R_{RT} = 82\text{k}$ (Note 12).

Symbol	Parameter	Condition	Min	Typ	Max	Units
I_{VDD}	Standby supply current (V_{DD1} , V_{DD2})	NSTBY = L SCK, SS, SI		1	8	μA
	No-boost supply current (V_{DD1} , V_{DD2})	NSTBY = H, EN_BOOST = L SCK, SS, SI Audio sync and LEDs OFF			400	μA
	No-load supply current (V_{DD1} , V_{DD2})	NSTBY = H, EN_BOOST = H SCK, SS, SI Audio sync and LEDs OFF Autoload OFF			1	mA
	RGB drivers (V_{DD1} , V_{DD2})	CC mode at R1, G1, B1 and R2, G2, B2 set to 15mA SW mode		150		μA
	WLED drivers (V_{DD1} , V_{DD2})	4+2 banks I_{OUT}/LED 25mA		500		μA
	Audio synchronization (V_{DD1} , V_{DD2})	Audio sync ON $V_{DD1,2} = 2.8\text{V}$ $V_{DD1,2} = 3.6\text{V}$		390	700	μA
	Flash (V_{DD1} , V_{DD2})	$I(R_{FLASH}) = 1\text{mA}$ Peak current during flash		2		mA
I_{VDDIO}	V_{DDIO} Standby Supply current	NSTBY = L SCK, SS, SI = H			1	μA
	V_{DDIO} supply current	1MHz SCK frequency in SPI mode, $C_L = 50\text{pF}$ at SO pin		20		μA
I_{EXT_LDO}	External LDO output current (V_{DD1} , V_{DD2} , V_{DDA})	7V tolerant application only $I_{BOOST} = 300\text{mA}$			6.5	mA
V_{DDA}	Output voltage of internal LDO for analog parts	(Note 13)	2.72	2.80	2.88	V
			-3		+3	%

Note 1: Absolute Maximum Ratings indicate limits beyond which damage to the component may occur. Operating Ratings are conditions under which operation of the device is guaranteed. Operating Ratings do not imply guaranteed performance limits. For guaranteed performance limits and associated test conditions, see the Electrical Characteristics tables.

Note 2: All voltages are with respect to the potential at the GND pins.

Note 3: Battery/Charger voltage should be above 6V no more than 10% of the operational lifetime.

Note 4: Voltage tolerance of LP3954 above 6.0V relies on fact that V_{DD1} and V_{DD2} (2.8V) are available (ON) at all conditions. If V_{DD1} and V_{DD2} are not available (ON) at all conditions, National Semiconductor does not guarantee any parameters or reliability for this device.

Note 5: The total load current of the boost converter in worst-case conditions should be limited to 300mA (min. input and max. output voltage).

Note 6: Internal thermal shutdown circuitry protects the device from permanent damage. Thermal shutdown engages at $T_J = 160^\circ\text{C}$ (typ.) and disengages at $T_J = 140^\circ\text{C}$ (typ.).

Note 7: For detailed soldering specifications and information, please refer to National Semiconductor Application Note AN1112 : Micro SMD Wafer Level Chip Scale Package or Application Note AN1412 : Micro SMDxt Wafer Level Chip Scale Package.

Note 8: The Human body model is a 100pF capacitor discharged through a 1.5k Ω resistor into each pin. The machine model is a 200pF capacitor discharged directly into each pin. MIL-STD-883 3015.7

Note 9: In applications where high power dissipation and/or poor package thermal resistance is present, the maximum ambient temperature may have to be derated. Maximum ambient temperature (T_{A-MAX}) is dependent on the maximum operating junction temperature ($T_{J-MAX-OP} = 125^\circ\text{C}$), the maximum power dissipation of the device in the application (P_{D-MAX}), and the junction-to ambient thermal resistance of the part/package in the application (θ_{JA}), as given by the following equation: $T_{A-MAX} = T_{J-MAX-OP} - (\theta_{JA} \times P_{D-MAX})$.

Note 10: Junction-to-ambient thermal resistance is highly application and board-layout dependent. In applications where high maximum power dissipation exists, special care must be paid to thermal dissipation issues in board design.

Note 11: Min and Max limits are guaranteed by design, test, or statistical analysis. Typical numbers are not guaranteed, but do represent the most likely norm.

Note 12: Low-ESR Surface-Mount Ceramic Capacitors (MLCCs) used in setting electrical characteristics.

Note 13: V_{DDA} output is not recommended for external use.

Block Diagram

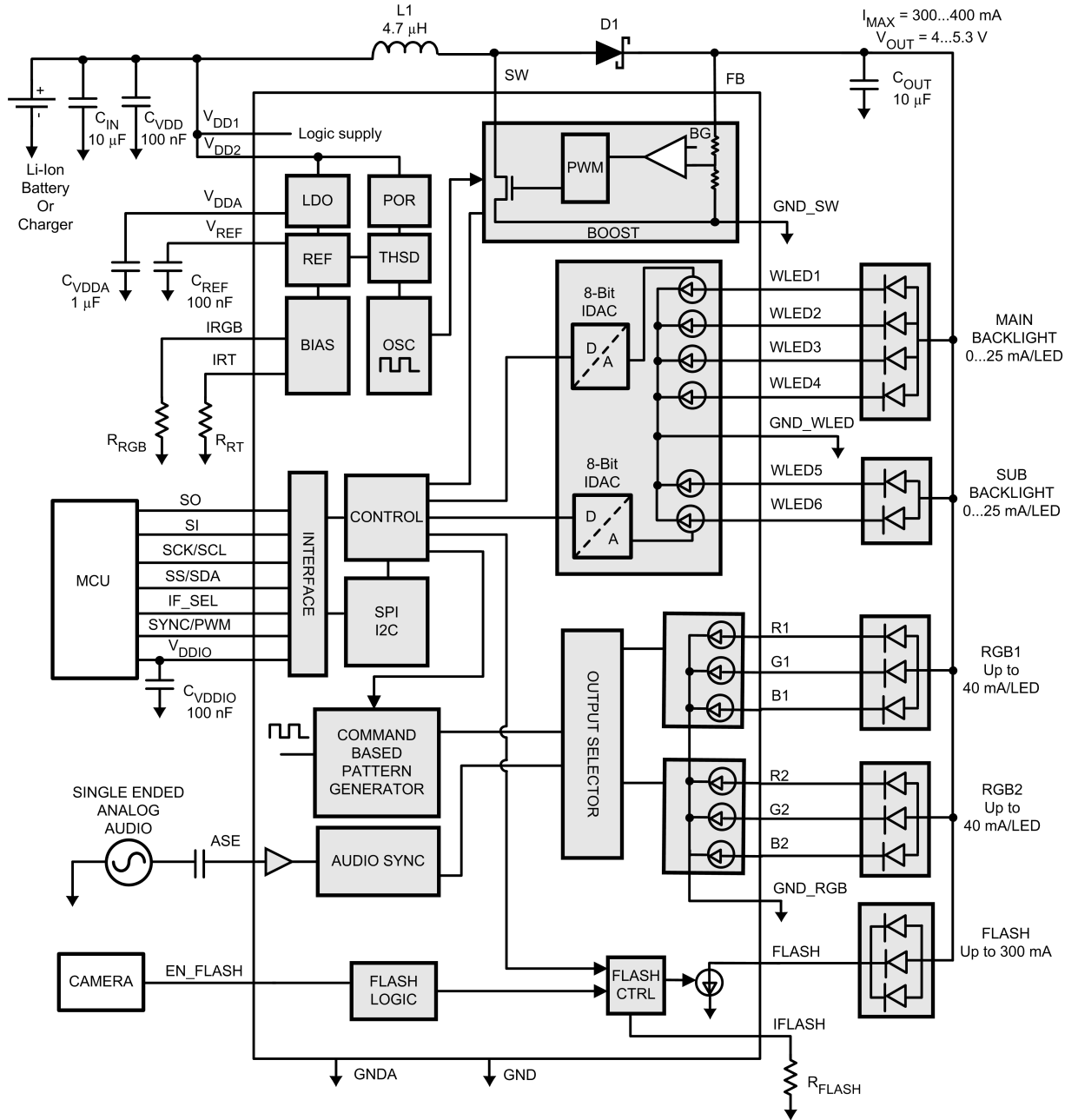

20132206

Modes of Operation

- RESET:** In the RESET mode all the internal registers are reset to the default values and the chip goes to STANDBY mode after reset. NSTBY control bit is low after reset by default. Reset is entered always if Reset Register is written or internal Power On Reset is active. There is no dedicated Reset pin available. LP3954 can be reset by writing any data to Reset Register in address 60H. Power On Reset (POR) will activate during the chip startup or when the supply voltage VDD2 falls below 1.5V. Once VDD2 rises above 1.5V, POR will inactivate and the chip will continue to the STANDBY mode.
- STANDBY:** The STANDBY mode is entered if the register bit NSTBY is LOW. This is the low power consumption mode, when all circuit functions are disabled. Registers can be written in this mode and the control bits are effective immediately after power up.
- STARTUP:** When NSTBY bit is written high, the INTERNAL STARTUP SEQUENCE powers up all the needed internal blocks (Vref, Bias, Oscillator etc..). To ensure the correct oscillator initialization, a 10ms delay is generated by the internal state-machine. If the chip temperature rises too high, the Thermal Shutdown (THSD) disables the chip operation and STARTUP mode is entered until no thermal shutdown event is present.
- BOOST STARTUP:** Soft start for boost output is generated in the BOOST STARTUP mode. The boost output is raised in PFM mode during the 10ms delay generated by the state-machine. The Boost startup is entered from Internal Startup Sequence if EN_BOOST is HIGH or from Normal mode when EN_BOOST is written HIGH. During the 10ms Boost Startup time all LED outputs are switched off to ensure smooth start-up.
- NORMAL:** During NORMAL mode the user controls the chip using the Control Registers. The registers can be written in any sequence and any number of bits can be altered in a register in one write

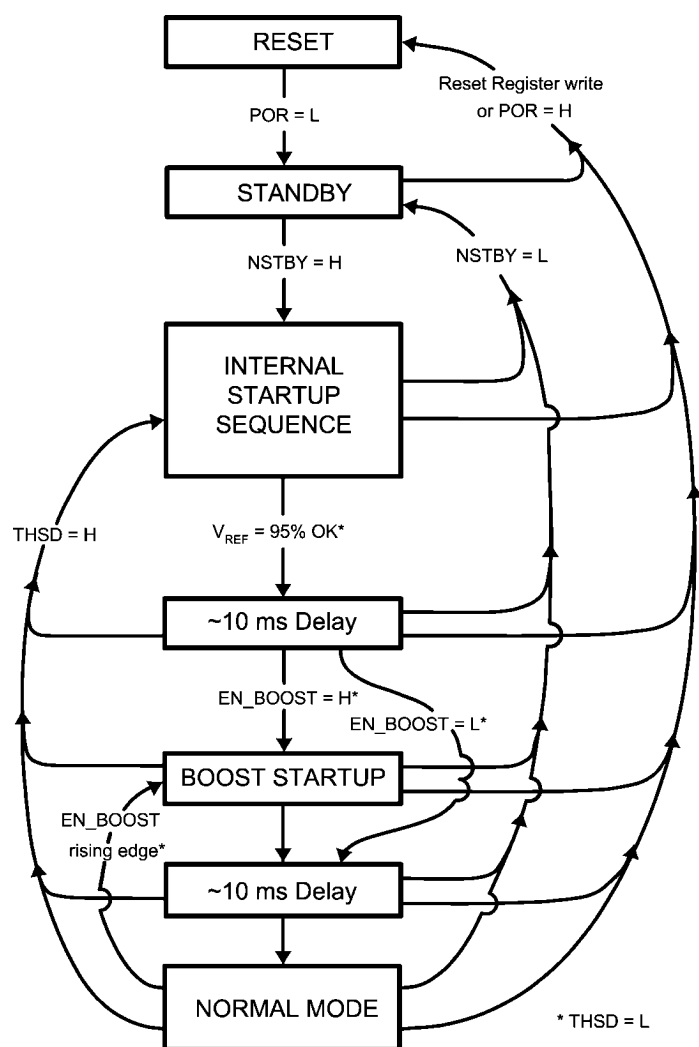

20132207

Magnetic Boost DC/DC Converter

The LP3954 Boost DC/DC Converter generates a 4.0 – 5.3V voltage for the LEDs from single Li-Ion battery (3V...4.5V). The output voltage is controlled with an 8-bit register in 9 steps. The converter is a magnetic switching PWM mode DC/DC converter with a current limit. The converter has three options for switching frequency, 1MHz, 1.67MHz and 2MHz (default), when timing resistor R_T is 82k Ω . Timing resistor defines the internal oscillator frequency and thus directly affects boost frequency and all circuit's internally generated timing (RGB, Flash, WLED fading).

The LP3954 Boost Converter uses pulse-skipping elimination to stabilize the noise spectrum. Even with light load or no load a minimum length current pulse is fed to the inductor. An active load is used to remove the excess charge from the output capacitor at very light loads. At very light load and when input and output voltages are very close to each other, the pulse skipping is not completely eliminated. Output voltage should be at least 0.5V higher than input voltage to avoid pulse skipping. Reducing the switching frequency will also reduce the required voltage difference.

Active load can be disabled with the en_autoload bit. Disabling will increase the efficiency at light loads, but the downside is that pulse skipping will occur. The Boost Converter should be stopped when there is no load to minimise the current consumption.

The topology of the magnetic boost converter is called CPM control, current programmed mode, where the inductor current is measured and controlled with the feedback. The user can program the output voltage of the boost converter. The output voltage control changes the resistor divider in the feedback loop.

The following figure shows the boost topology with the protection circuitry. Four different protection schemes are implemented:

1. Over voltage protection, limits the maximum output voltage
 - Keeps the output below breakdown voltage.
 - Prevents boost operation if battery voltage is much higher than desired output.
2. Over current protection, limits the maximum inductor current
 - Voltage over switching NMOS is monitored; too high voltages turn the switch off.
3. Feedback break protection. Prevents uncontrolled operation if FB pin gets disconnected.
4. Duty cycle limiting, done with digital control.

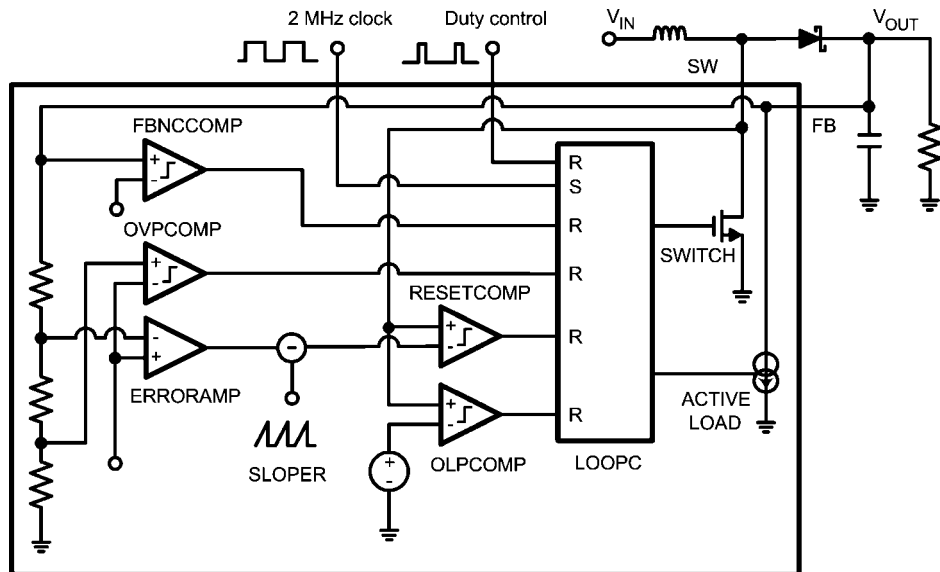

Boost Converter Topology

20132208

MAGNETIC BOOST DC/DC CONVERTER ELECTRICAL CHARACTERISTICS

Symbol	Parameter	Conditions	Min	Typ	Max	Units
I _{LOAD}	Load Current	3.0V ≤ V _{IN} V _{OUT} = 5V	0		300	mA
		3.0V ≤ V _{IN} V _{OUT} = 4V	0		400	
V _{OUT}	Output Voltage Accuracy (FB Pin)	3.0V ≤ V _{IN} ≤ V _{OUT} - 0.5 V _{OUT} = 5.0V	-5		+5	%
	Output Voltage (FB Pin)	1 mA ≤ I _{LOAD} ≤ 300 mA V _{IN} > 5V + V _(SCHOTTKY)		V _{IN} -V _(SCHOTTKY)		V
RDS _{ON}	Switch ON Resistance	V _{DD1,2} = 2.8V, I _{SW} = 0.5A		0.4	0.8	Ω
f _{PWF}	PWM Mode Switching Frequency	RT = 82 kΩ freq_sel[2:0] = 1XX		2		MHz
	Frequency Accuracy	2.7 ≤ VDDA ≤ 2.9 RT = 82 kΩ	-6 -9	±3	+6 +9	%
t _{PULSE}	Switch Pulse Minimum Width	no load		25		ns
t _{STARTUP}	Startup Time	Boost startup from STANDBY		10		ms
I _{SW_MAX}	SW Pin Current Limit		700 550	800	900 950	mA

BOOST STANDBY MODE

User can stop the Boost Converter operation by writing the Enables register bit EN_BOOST low. When EN_BOOST is written high, the converter starts for 10ms in PFM mode and then goes to PWM mode.

BOOST OUTPUT VOLTAGE CONTROL

User can control the boost output voltage by boost output 8-bit register.

Boost Output [7:0] Register 0DH		Boost Output Voltage (typical)
Bin	Hex	
0000 0000	00	4.00
0000 0001	01	4.25
0000 0011	03	4.40
0000 0111	07	4.55
0000 1111	0F	4.70
0001 1111	1F	4.85
0011 1111	3F	5.00 Default
0111 1111	7F	5.15
1111 1111	FF	5.30

Boost Output Voltage Control

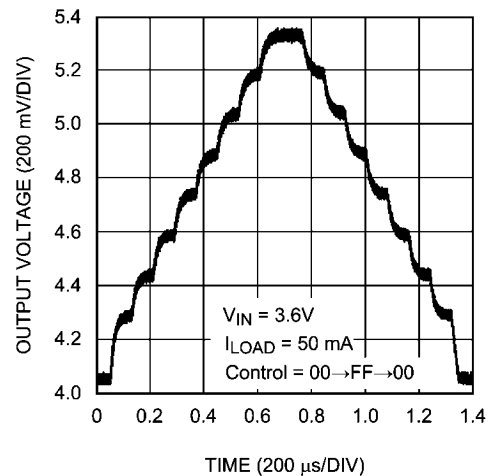

20132209

BOOST FREQUENCY CONTROL

freq_sel[2:0]	frequency
1XX	2.00 MHz
01X	1.67 MHz
001	1.00 MHz

Register 'boost freq' (address 0EH). Register default value after reset is 07H.

Boost Converter Typical Performance Characteristics

$V_{in} = 3.6V$, $V_{out} = 5.0V$ if not otherwise stated

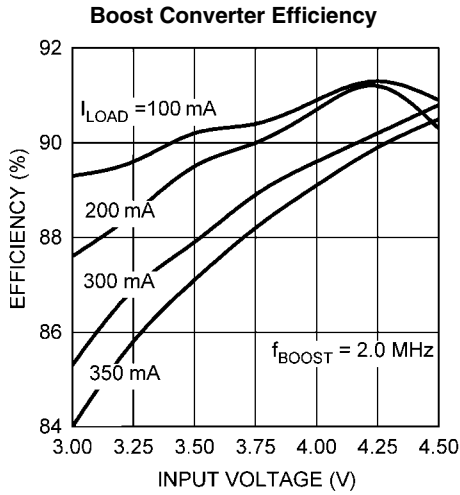

20132210

Boost Typical Waveforms at 100mA Load

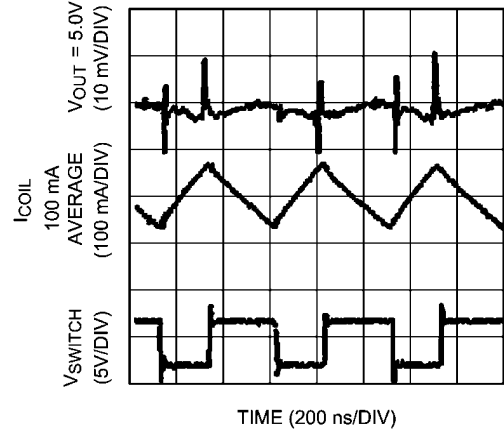

20132211

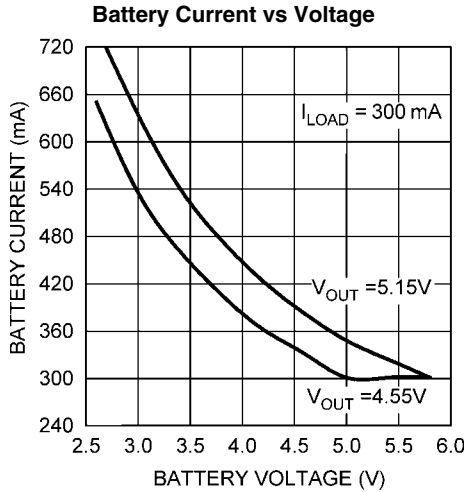

20132212

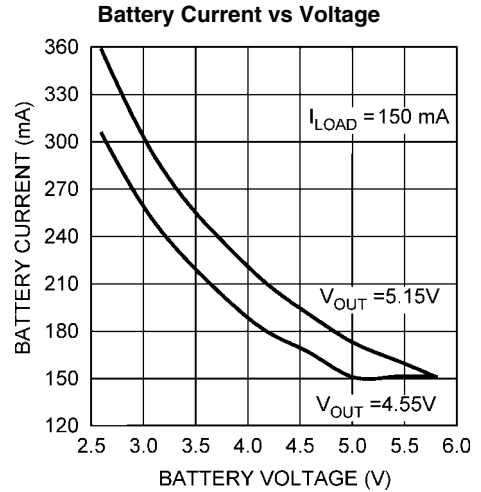

20132213

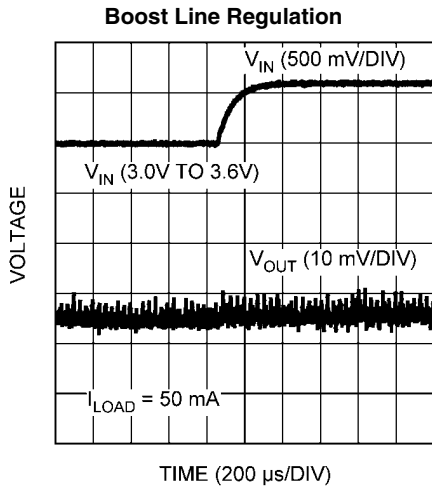

20132214

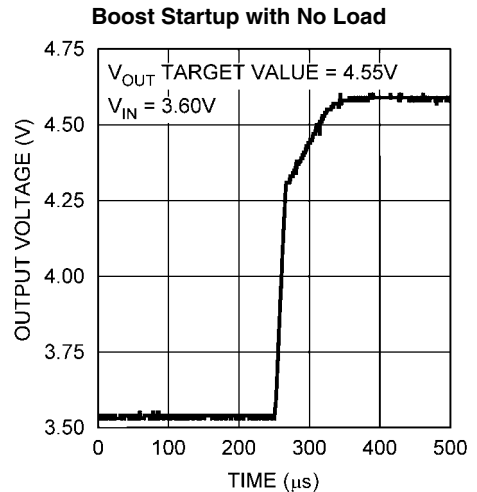

20132215

Boost Load Transient, 50 mA–100 mA

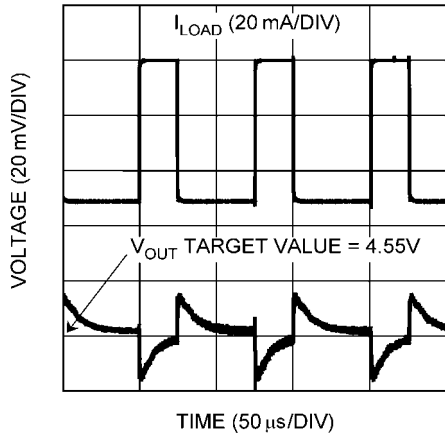

20132216

Boost Switching Frequency

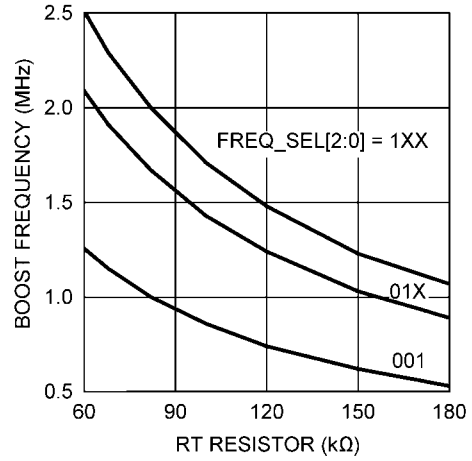

20132217

Output Voltage vs Load Current

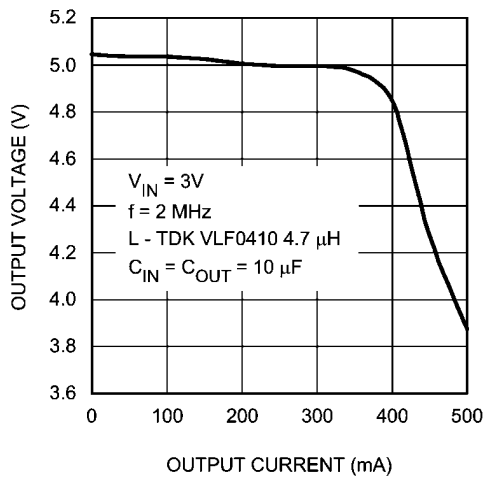

20132261

Efficiency At Low Load vs Autoload

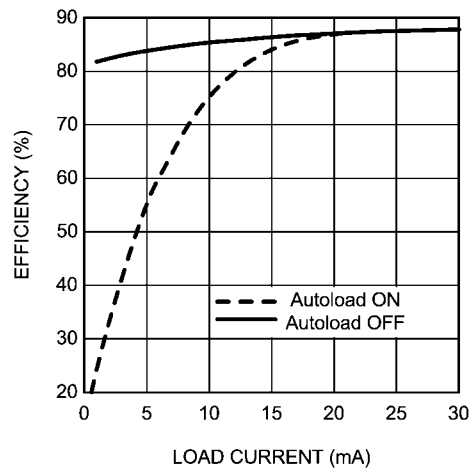

20132262

Functionality of Color LED Outputs (R1, G1, B1; R2, G2, B2)

LP3954 has 2 sets of RGB/color LED outputs. Both sets have 3 outputs and the sets can be controlled in 4 different ways:

1. Command based pattern generator control (internal PWM)
2. Audio synchronization control
3. Direct ON/OFF control
4. External PWM control

By using **command based pattern generator** user can program any kind of color effect patterns. LED intensity, blinking cycles and slopes are independently controlled with 8 16-bit commands. Also real time commands are possible as well as loops and step by step control. If analog audio is available on system, the user can use **audio synchronization** for synchronizing LED blinking to the music. The different modes together with the various sub modes generate very colorful and interesting lighting effects. **Direct ON/OFF** control is mainly for switching on and off LEDs. **External PWM control** is for applications where external PWM signal is available and required to control the color LEDs. PWM signal can be connected to any color LED separately as shown later.

COLOR LED CONTROL MODE SELECTION

The RGB_SEL[1:0] bits in the Enables register (08H) control the output modes for RGB1 (R1, G1, B1) and RGB2 (R2, G2, B2) outputs. The following table shows the RGB_SEL functionality.

RGB_SEL[1:0]	Audio sync connected to	Command based pattern generator connected to
00	none	RGB1 & RGB2
01	RGB1	RGB2
10	RGB2	RGB1
11	RGB1 & RGB2	none

RGB Control register (00H) has control bits for direct on/off control of all color LEDs. Note that the LEDs have to be turned on in order to control them with audio synchronization or pattern generator.

The external PWM signal controls any LED depending on the control register setup. The controls are in the Ext. PWM Control register (address 07H) except the FLASH control in HC_Flash (10H) register as follows:

Ext. PWM Control		
wled1-4_pwm	bit 7	PWM controls WLED 1-4
wled5-6_pwm	bit 6	PWM controls WLED 5-6
r1_pwm	bit 5	PWM controls R1 output
g1_pwm	bit 4	PWM controls G1 output
b1_pwm	bit 3	PWM controls B1 output
r2_pwm	bit 2	PWM controls R2 output
g2_pwm	bit 1	PWM controls G2 output
b2_pwm	bit 0	PWM controls B2 output

HC_Flash		
hc_pwm	bit 5	PWM controls High Current FLASH

Note: If DISPL=1, wled1-4pwm controls WLED1-6

Note: Maximum external PWM frequency is 1kHz. If during the external PWM control the internal PWM is on the result will be product of both functions.

CURRENT CONTROL OF COLOR LED OUTPUTS (R1, R2, G1, G2, B1, B2)

Both RGB output sets can be separately controlled as constant current sinks or as switches. This is done using cc_rgb1/2 bits in the RGB control register. In constant current mode one or both RGB output sets are controlled with constant current sinks (no external ballast resistors required). The maximum output current for both drivers is set by one external resistor R_{RGB}. User can decrease the maximum current for an individual LED driver by programming as shown later.

The maximum current for all RGB drivers is set with R_{RGB}. The equation for calculating the maximum current is

$$I_{MAX} = 100 \times 1.23V / (R_{RGB} + 50\Omega)$$

where

I_{MAX} - maximum RGB current in any RGB output in constant current mode

1.23V - reference voltage

100 - internal current mirror multiplier

R_{RGB} - resistor value in Ohms

50Ω - internal resistor in the I_{RGB} input

For example if 22mA is required for maximum RGB current R_{RGB} equals to

$$R_{RGB} = 100 \times 1.23V / I_{MAX} - 50\Omega = 123V / 0.022A - 50\Omega = 5.54k\Omega$$

Each individual RGB output has a separate maximum current programming. The control bits are in registers **RGB1 max current** and **RGB2 max current** (12H and 13H) and programming is shown in table below. The default value after reset is 00.

IR1[1:0], IG1[1:0], IB1[1:0], IR2[1:0], IG2[1:0], IB2[1:0]	Maximum current/output
00	0.25 × I _{MAX}
01	0.50 × I _{MAX}
10	0.75 × I _{MAX}
11	1.00 × I _{MAX}

SWITCH MODE

The switch mode is used if there is a need to connect parallel LEDs to output or if the RGB output current needs to be increased.

Please note that the switch mode **requires an external ballast resistors** at each output to limit the LED current.

The switch/current mode and on/off controls for RGB are in the RGB_ctrl register (00H) as follows:

RGB_ctrl register (00H)

CC_RGB1	bit7	1	R1, G1 and B1 are switches → limit current with ballast resistor
		0	R1, G1 and B1 are constant current sinks, current limited internally
CC_RGB2	bit6	1	R2, G2 and B2 are switches → limit current with ballast resistor
		0	R2, G2 and B2 are constant current sinks, current limited internally
r1sw	bit5	1	R1 is on
		0	R1 is off
g1sw	bit4	1	G1 is on
		0	G1 is off
b1sw	bit3	1	B1 is on
		0	B1 is off
r2sw	bit2	1	R2 is on
		0	R2 is off
g2sw	bit1	1	G2 is on
		0	G2 is off
b2sw	bit0	1	B2 is on
		0	B2 is off

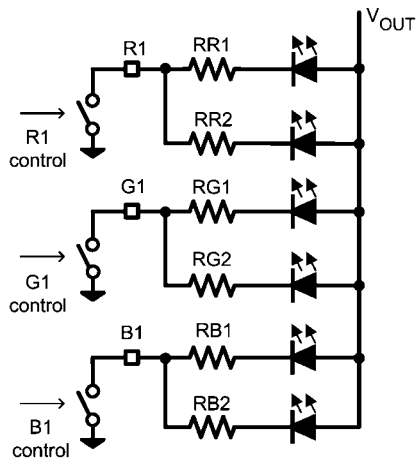

RGB1 output as switch (SW)

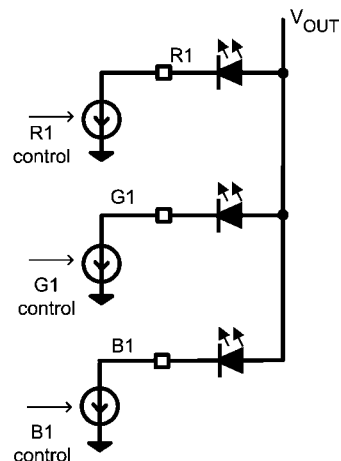

RGB1 output as a constant current sink (CC)

20132218

Command Based Pattern Generator for Color LEDs

The LP3954 has a unique stand-alone command based pattern generator with 8 user controllable 16-bit wide commands. Since write registers are 8-bit long one command requires 2 write cycles. Each command has intensity level for each LED, command execution time (CET) and transition time (TT). The command structure is shown in following two figures.

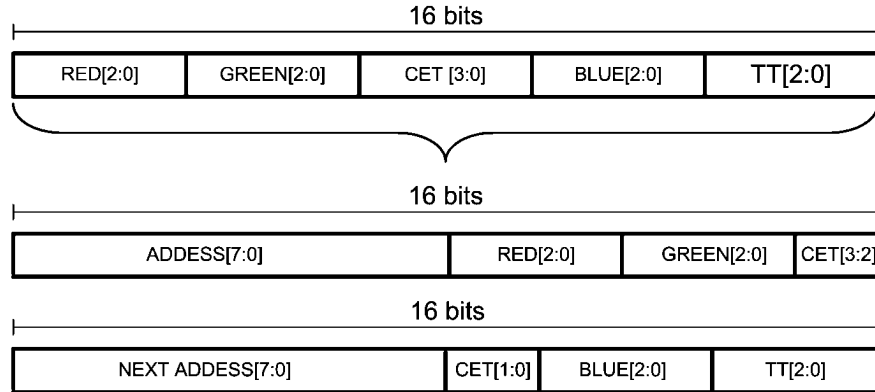

20132219

COMMAND REGISTER WITH 8 COMMANDS

COMMAND 1	ADDRESS 50H	R2	R1	R0	G2	G1	G0	CET3	CET2
	ADDRESS 51H	CET1	CET0	B2	B1	B0	TT2	TT1	TT0
COMMAND 2	ADDRESS 52H	R2	R1	R0	G2	G1	G0	CET3	CET2
	ADDRESS 53H	CET1	CET0	B2	B1	B0	TT2	TT1	TT0
COMMAND 3	ADDRESS 54H	R2	R1	R0	G2	G1	G0	CET3	CET2
	ADDRESS 55H	CET1	CET0	B2	B1	B0	TT2	TT1	TT0
COMMAND 4	ADDRESS 56H	R2	R1	R0	G2	G1	G0	CET3	CET2
	ADDRESS 57H	CET1	CET0	B2	B1	B0	TT2	TT1	TT0
COMMAND 5	ADDRESS 58H	R2	R1	R0	G2	G1	G0	CET3	CET2
	ADDRESS 59H	CET1	CET0	B2	B1	B0	TT2	TT1	TT0
COMMAND 6	ADDRESS 5AH	R2	R1	R0	G2	G1	G0	CET3	CET2
	ADDRESS 5BH	CET1	CET0	B2	B1	B0	TT2	TT1	TT0
COMMAND 7	ADDRESS 5CH	R2	R1	R0	G2	G1	G0	CET3	CET2
	ADDRESS 5DH	CET1	CET0	B2	B1	B0	TT2	TT1	TT0
COMMAND 8	ADDRESS 5EH	R2	R1	R0	G2	G1	G0	CET3	CET2
	ADDRESS 5FH	CET1	CET0	B2	B1	B0	TT2	TT1	TT0

COLOR INTENSITY CONTROL

Each color, Red, Green and Blue, has 3-bit intensity levels. The level control is logarithmic. 2 logarithmic curves are available. The LOG bit in Pattern_gen_ctrl register (11H) defines the curve used. The values for both logarithmic curves are shown in following table.

R[2:0], G[2:0], B[2:0]	CURRENT [% × I _{MAX(COLOR)}]	
	LOG=0	LOG=1
000	0	0
001	7	1
010	14	2
011	21	4
100	32	10
101	46	21
110	71	46
111	100	100

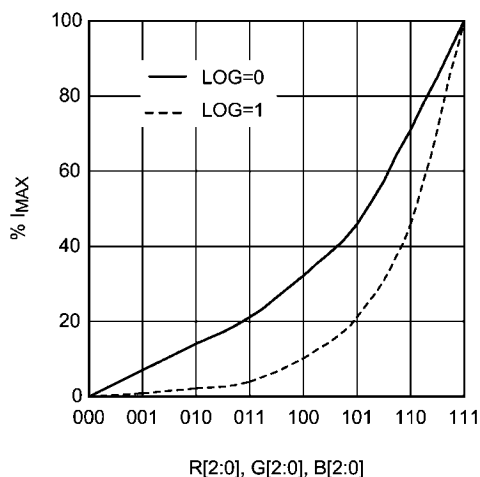

20132220

CET [3:0]	CET duration, ms
0000	197
0001	393
0010	590
0011	786
0100	983
0101	1180
0110	1376
0111	1573
1000	1769
1001	1966
1010	2163
1011	2359
1100	2556
1101	2753
1110	2949
1111	3146

Transition time TT is duration of transition from the previous RGB value to programmed new value. Transition times TT are defined as follows:

TT [2:0]	Transition time, ms
000	0
001	55
010	110
011	221
100	442
101	885
110	1770
111	3539

The figure below shows an example of RGB CET and TT times.

COMMAND EXECUTION TIME (CET) AND TRANSITION TIME (TT)

The command execution CET time is the duration of one single command. Command execution times CET are defined as follows, when R_T=82k:

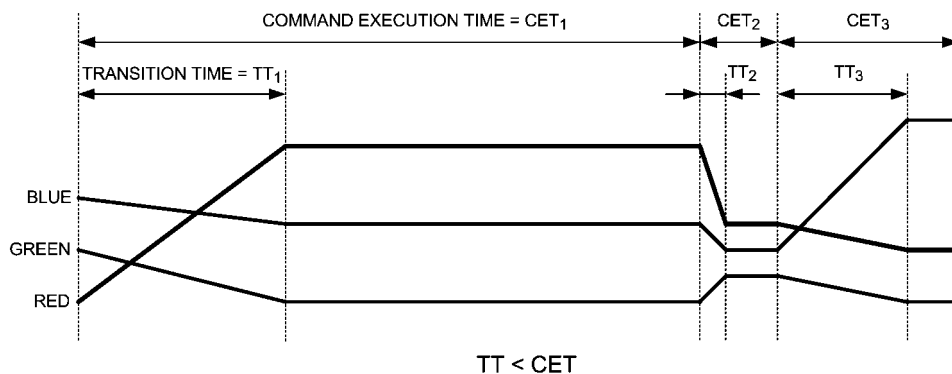

20132221

The command execution time also may be less than the transition time – the figure below illuminates this case.

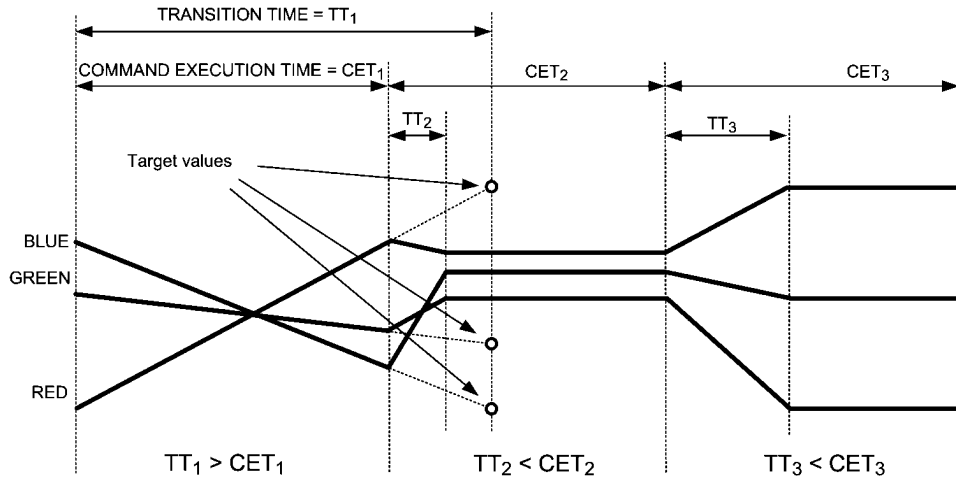

20132222

LOOP CONTROL

Pattern generator commands can be looped using the LOOP bit (D1) in Pattern gen ctrl register (11H). If LOOP=1 the program will be looped from the command 8 register or if there is 0000 0000 and 0000 0000 in one command register. The loop will start from command 1 and continue until stopped by writing rgb_start=0 or loop=0. The example of loop is shown in following figure:

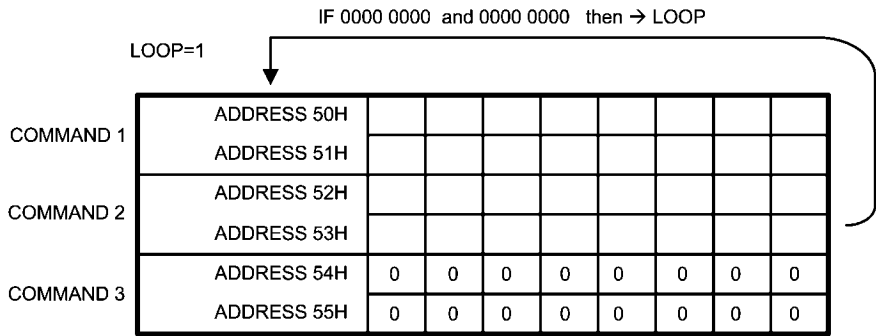

SINGLE PROGRAM

If control bit LOOP=0 the program will start from Command 1 and run to either last command or to empty “0000 0000 / 0000 0000” command.

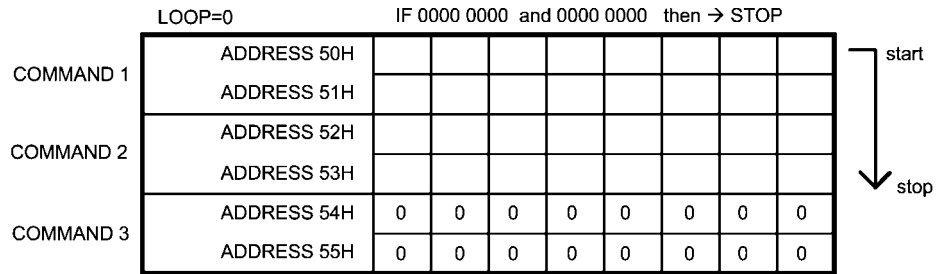

The LEDs maintain the brightness of the last command when the single program stops. Changes in command register will not be effective in this phase. The RGB_START bit has to be toggled off and on to make changes effective.

START BIT

Pattern_gen_ctrl register's RGB_START bit will enable command execution starting from Command 1.

Pattern gen ctrl register (11H)

rgb_start	Bit 2	0 – Pattern generator disabled 1 – execution pattern starting from command 1
loop	Bit 1	0 – pattern generator loop disabled (single pattern) 1 – pattern generator loop enabled (execute until stopped)
log	Bit 0	0 – color intensity mode 0 1 – color intensity mode 1

HARDWARE ON/OFF CONTROL AND DIMMING

PWM_LED input can be used as direct ON/OFF control or PWM dimming control for selected RGB outputs or the WLED groups. PWM_LED control can be enabled with the control bits in the **Ext. PWM Control** register.

Audio Synchronization

The color LEDs connected to RGB outputs can be synchronized to incoming audio with Audio Synchronization feature. Audio Sync has 2 modes. **Amplitude mode** synchronizes color LEDs based on input signal's peak amplitude. In the amplitude mode the user can select between 3 different amplitude mapping modes and 4 different speed configurations. The **frequency mode** synchronizes the color LEDs based on bass, middle and treble amplitudes (= low pass, band pass and high pass filters). User can select between 2 different frequency responses and 4 different speed configurations for best audio-visual user experience. Programmable gain and AGC function are also available for adjustment of input signal amplitude to light response. The Audio Sync functionality is described more closely below.

USING A DIGITAL PWM AUDIO SIGNAL AS AN AUDIO SYNCHRONIZATION SOURCE

If the input signal is a PWM signal, use a first or second order low pass filter to convert the digital PWM audio signal into an analog waveform. There are two parameters that need to be known to get the filter to work successfully: frequency of the PWM signal and the voltage level of the PWM signal. Suggested cut-off frequency (-3dB) should be around 2 kHz to 4 kHz and the stop-band attenuation at sampling frequency should be around -48dB or better. Use a resistor divider to reduce the digital signal amplitude to meet the specification of the analog audio input. Because a low-order low-pass filter attenuates the high-frequency components from audio signal, **MODE_CONTROL=[01]** selection is recommended when frequency synchronization mode is enabled. Application exam-

ple 5 shows an example of a second order RC-filter for 29 kHz PWM signal with 3.3V amplitude. Active filters, such as a Sallen-Key filter, may also be applied. An active filter gives better stop-band attenuation and cut-off frequency can be higher than for a RC-filter.

To make sure that the filter rolls off sufficiently quickly, connect your filter circuit to the audio input(s), turn on the audio synchronization feature, set manual gain to maximum, apply the PWM signal to the filter input and keep an eye on LEDs. If they are blinking without an audio signal (modulation), a sharper roll-off after the cut-off frequency, more stop-band attenuation, or smaller amplitude of the PWM signal is required.

AUDIO SYNCHRONIZATION SIGNAL PATH

LP3954 audio synchronization is mainly done digitally and it consists of the following signal path blocks:

- Input Buffers
- AD Converter
- DC Remover
- Automatic Gain Control (AGC)
- Programmable Gain
- 3 Band Digital Filter
- Peak Detector
- Look-up Tables (LUT)
- Mode Selector
- Integrators
- PWM Generator
- Output Drivers

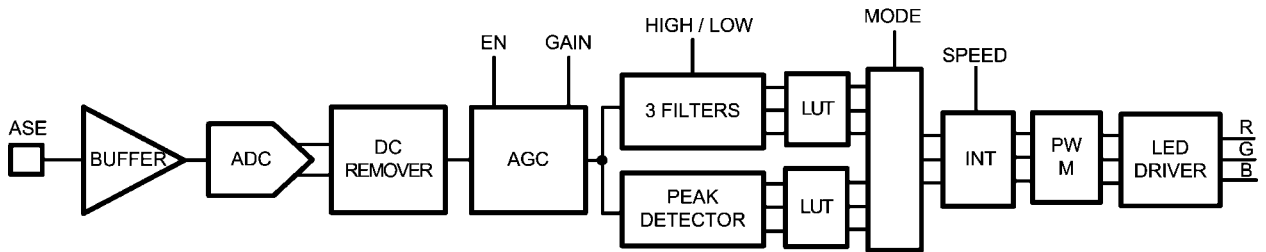

The digitized input signal has DC component that is removed by digital **DC REMOVER** (-3dB @ 400Hz). Since the light response of input audio signal is very much amplitude dependent the AGC adjusts the input signal to suitable range automatically. User can disable **AGC** and the gain can be set manually with **PROGRAMMABLE GAIN**. LP3954 has 2 audio synchronization modes: amplitude and frequency. For amplitude based synchronization the **PEAK DETECTION** method is used. For frequency based synchronization **3 BAND FILTER** separates high pass, low pass and band bass signals. For both modes the predefined LUT is used to optimize the audio visual effect. **MODE SELECTOR** selects the synchronization mode. Different response times to music beat can be selected using **INTEGRATOR** speed variables. Finally **PWM GENERATOR** sets the driver FET duty cycles.

scribed in the Audio Sync table. The buffer is rail-to-rail input operational amplifier connected as a voltage follower. DC level of the input signal is set by a simple resistor divider

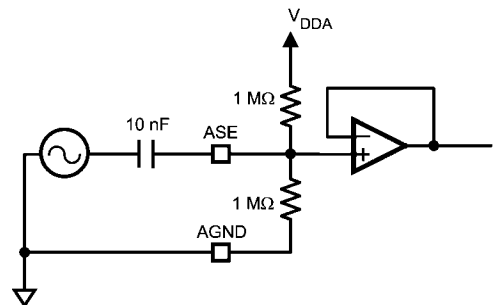

INPUT SIGNAL TYPE AND BUFFERING

LP3954 supports single ended audio input as shown in the figure below. The electric parameters of the buffer are de-

AUDIO SYNC ELECTRICAL PARAMETERS

Symbol	Parameter	Conditions	Min	Typical	Max	Units
Z_{IN}	Input Impedance of ASE		250	500		kOhm
A_{IN}	Audio Input Level Range (peak-to-peak)	Gain = 21dB Gain = 0 dB	0.1		$V_{DDA}-0.1$	V
f_{3dB}	Crossover Frequencies (-3 dB) Narrow Frequency Response Wide Frequency Response	Low Pass Band Pass High Pass Low Pass Band Pass High Pass		0.5 1.0 and 1.5 2.0 1.0 2.0 and 3.0 4.0		kHz

CONTROL OF AUDIO SYNCHRONIZATION

The following table describes the controls required for audio synchronization.

Audio_sync_CTRL1 (2AH)		
GAIN_SEL[2:0]	Bits 7-5	Input signal gain control. Range 0...21 dB, step 3 dB: [000] = 0 dB (default) [011] = 9 dB [110] = 18 dB [001] = 3 dB [100] = 12 dB [111] = 21 dB [010] = 6 dB [101] = 15 dB
SYNC_MODE	Bit 4	Synchronization mode selector. SYNCMODE = 0 → Amplitude Mode (default) SYNCMODE = 1 → Frequency Mode
EN_AGC	Bit 3	Automatic Gain Control enable 1 = enabled 0 = disabled (Gain Select enabled) (default)
EN_SYNC	Bit 2	Audio synchronization enable 1 = Enabled Note : If AGC is enabled, AGC gain starts from current GAIN_SEL gain value. 0 = Disabled (default)
INPUT_SEL[1:0]	Bits 1-0	[00] = Single ended input signal, ASE. [01] = Temperature measurement [10] = Ambient light measurement [11] = No input (default)
Audio_sync_CTRL2 (2BH)		
EN_AVG	Bit 4	0 – average disabled (not applicable in audio synchronization mode) 1 – average enabled (not applicable in audio synchronization mode)
MODE_CTRL[1:0]	Bits 3-2	See below: Mode control
SPEED_CTRL[1:0]	Bits 1-0	Sets the LEDs light response time to audio input. [00] = FASTEST (default) [01] = FAST [10] = MEDIUM [11] = SLOW (For SLOW setting in amplitude mode $f_{MAX}=3.8\text{Hz}$, Frequency mode $f_{MAX}=7.6\text{Hz}$)

MODE CONTROL IN FREQUENCY MODE

Mode control has two setups based on audio synchronization mode select: the frequency mode and the amplitude mode. During the **frequency mode** user can select two filter options by MODE_CTRL as shown below. User can select the filters based on the music type and light effect requirements. In the first mode the frequency range extends to 8 kHz in the second to 4 kHz.

The lowpass filter is used for the red, the bandpass filter for the blue and the hipass filter for the green LED.

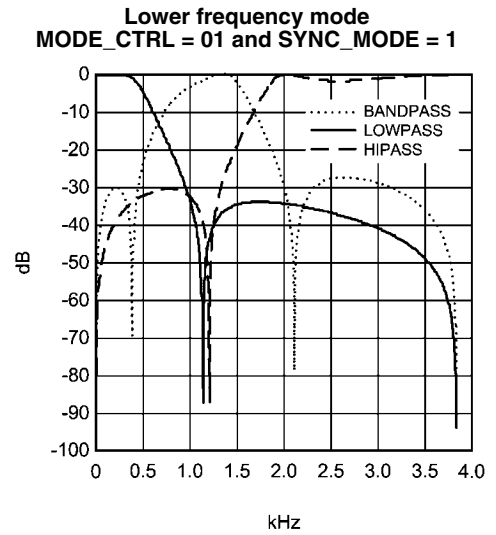
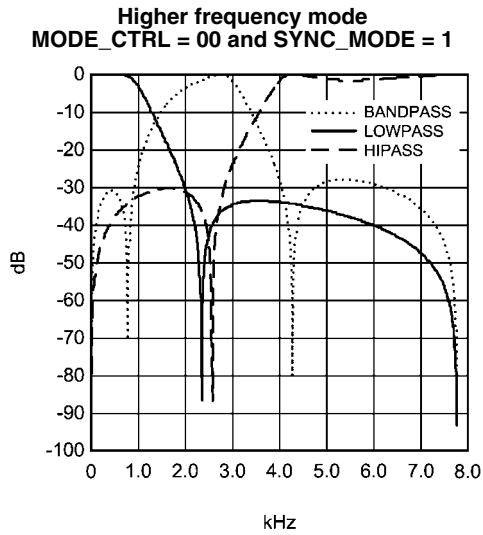

MODE CONTROL IN AMPLITUDE MODE

During the **amplitude synchronization mode** user can select between three different amplitude mappings by using MODE_CTRL select. These three mapping option gives different light response. The modes are shown in the tables below.

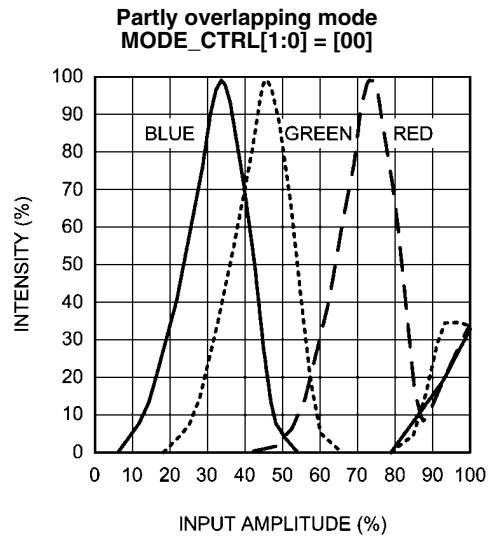
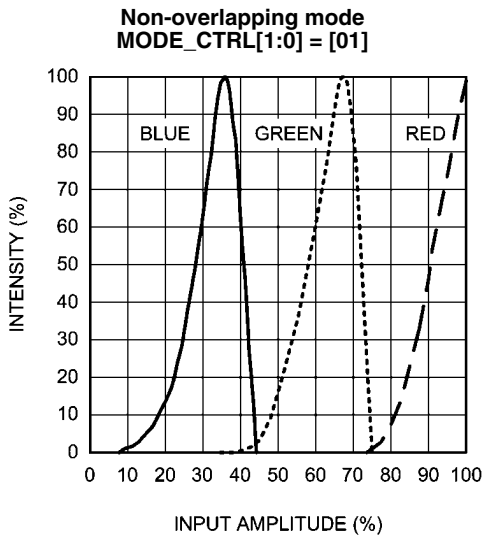

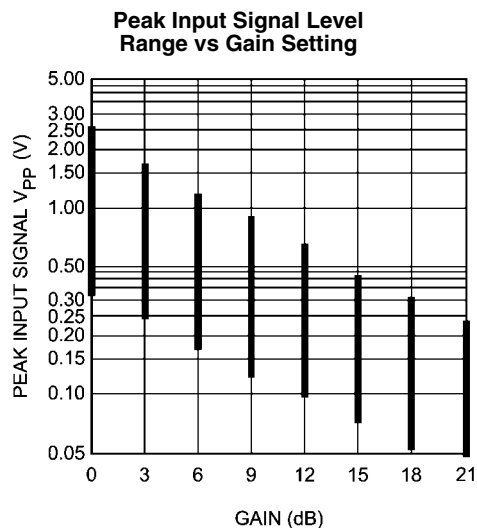
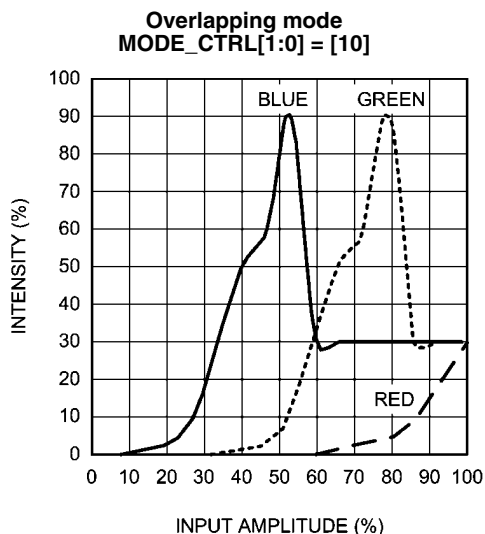

RGB OUTPUT SYNCHRONIZATION TO EXTERNAL CLOCK

The RGB pattern generator and high current flash driver timing can be synchronized to external clock with following configuration.

1. Set PWM_SYNC bit in Enables register to 1
2. Feed PWM_SYNC pin with 5 MHz clock

By this the internal 5 MHz clock is disabled from pattern generator and flash timing circuitry.

The external clock signal frequency will fully determine the timings related to RGB and Flash.

Note: The boost converter will use internal 5 MHz clock even if the external clock is available.

RGB Driver Typical Performance Characteristics

RGB DRIVER ELECTRICAL CHARACTERISTICS (R1, G1, B1, R2, G2, B2 OUTPUTS)

Symbol	Parameter	Condition	Min	Typ	Max	Units
$I_{LEAKAGE}$	R1, G1, B1, R2, G2, B2 pin leakage current			0.1	1	μ A
$I_{MAX(RGB)}$	Maximum recommended sink current	CC mode			40	mA
		SW mode			50	mA
	Accuracy @ 37mA	$R_{RGB}=3.3\text{ k}\Omega \pm 1\%$, CC mode		± 5		%
	Current mirror ratio	CC mode		1:100		
	RGB1 and RGB2 current mismatch	$I_{RGB}=37\text{mA}$, CC mode		± 5		%
R_{SW}	Switch resistance	SW mode		2.5	4	Ω
f_{RGB}	RGB switching frequency	Accuracy proportional to internal clock freq.	18.2	20	21.8	kHz
		If external SYNC 5MHz is in use		20		kHz

Note: RGB current should be limited as follows:

constant current mode – limit by external R_{RGB} resistor;

switch mode – limit by external ballast resistors

Output Current vs Pin Voltage (Current Sink Mode)

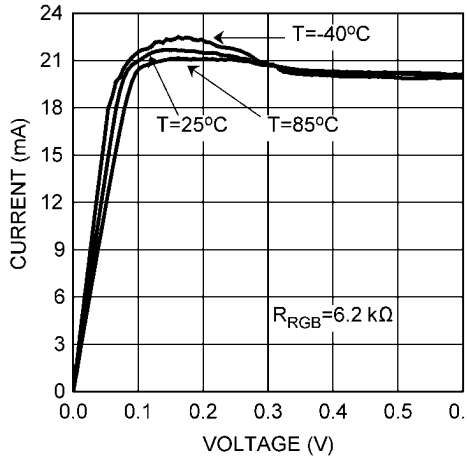

20132266

Pin Voltage vs Output Current (Switch Mode)

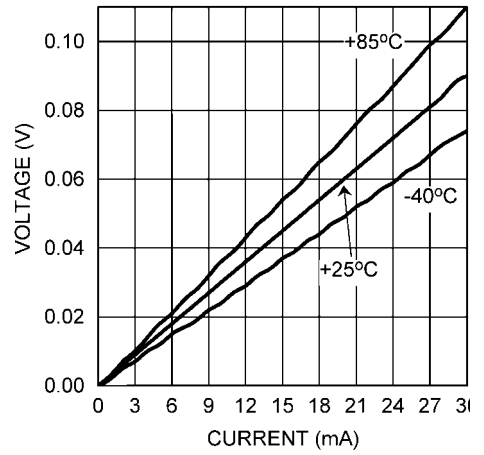

20132268

Output Current vs R_{RGB} (Current Sink Mode)

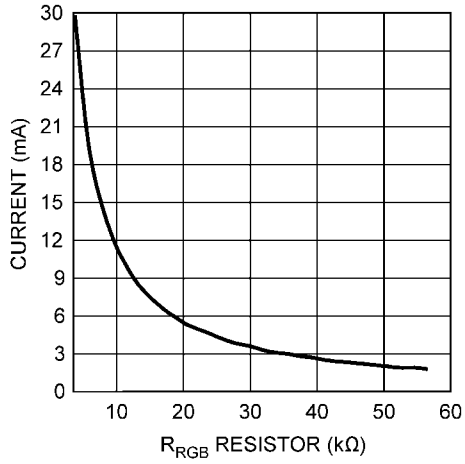

20132267

Single High Current Driver

LP3954 has internal constant current driver that is capable for driving high current mainly targeted for FLASH LED in camera phone applications.

MAXIMUM CURRENT SETUP FOR FLASH

The user sets the maximum current of FLASH with R_{FLASH} resistor based on following equation:

$$I_{MAX} = 300 \times 1.23V / (R_{FLASH} + 50\Omega),$$

where

I_{max} = maximum flash current in Amps (ie. 0.3A)

1.23V = reference voltage

300 = internal current mirror multiplier

R_{FLASH} = Resistor value in Ohms

50Ω = Internal resistor in the I_{FLASH} input

For example if 300mA is required for maximum flash current R_{FLASH} equals to

$$R_{FLASH} = 300 \times 1.23V / I_{MAX} - 50\Omega = 369V / 0.3A - 50\Omega = 1.18k\Omega$$

CURRENT CONTROL FOR FLASH

To minimize the internal current consumption, the flash function has an enable bit $EN_{HCFLASH}$ in the HC_Flash register.

EN_HCFLASH	
0	FLASH disabled, no extra current consumption through R_{FLASH}
1	FLASH enabled, I_{FLASH} set by $HC_SW[1:0]$ (see below)

$HC[1:0]$ bits in the HC_Flash register control the FLASH current as show in following table.

FL_T[1:0]	Flash duration typ	Current during view finder/focusing	Current during FLASH
00	200ms	Set by $HC[1:0]$	$HC[11] = I_{MAX(FLASH)}$
01	400ms	Set by $HC[1:0]$	$HC[11] = I_{MAX(FLASH)}$
10	600ms	Set by $HC[1:0]$	$HC[11] = I_{MAX(FLASH)}$
11	EN_FLASH on duration	Set by $HC[1:0]$	$HC[11] = I_{MAX(FLASH)}$

HC[1:0]	I(FLASH)
00	$0.25 \times I_{MAX(FLASH)}$
01	$0.50 \times I_{MAX(FLASH)}$
10	$0.75 \times I_{MAX(FLASH)}$
11	$1.00 \times I_{MAX(FLASH)}$

The figure below shows the internal structure for the FLASH driver.

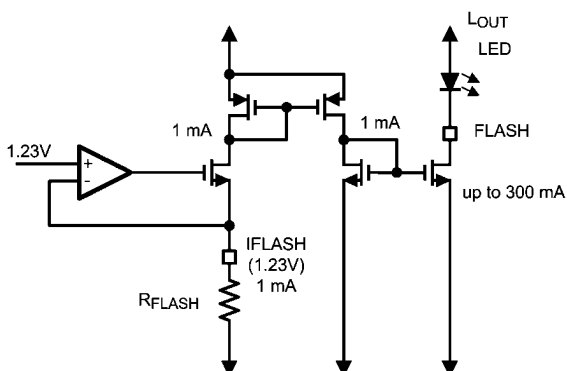

20132233

FLASH TIMING

Flash output is turned on in lower current **View finder** mode when the $EN_{HCFLASH}$ bit is written high. The actual Flash at maximum current starts when the EN_{FLASH} i/o-pin goes high. The Flash length can be selected from 3 pre-defined values or EN_{FLASH} pin pulse length can determine the length. The pulse length is controlled by the $FT_T[1:0]$ bits as show in the table below.

The following figure shows the functionality of the built-in flash

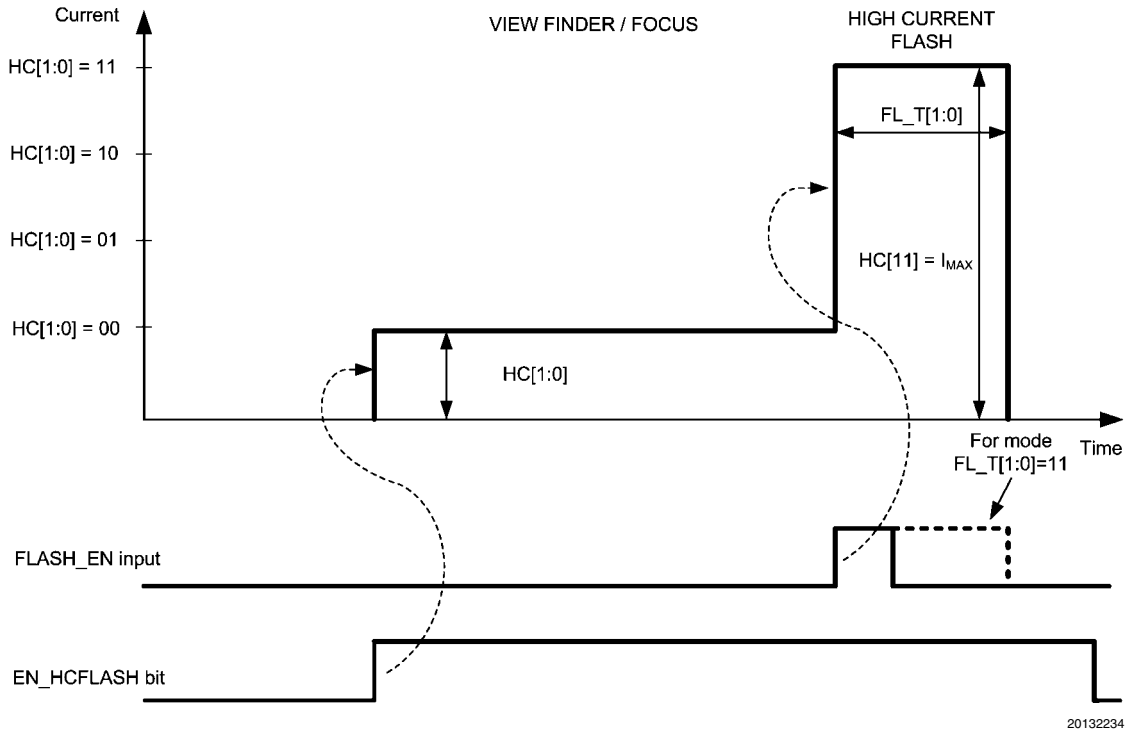

20132234

HIGH CURRENT DRIVER ELECTRICAL CHARACTERISTICS

Symbol	Parameter	Condition	Min	Typ	Max	Units
I _{LEAKAGE}	FLASH pin leakage current			0.1	2	μA
I _{MAX(FLASH)}	Maximum Sink Current				400	mA
	Accuracy @ 300 mA	R _{FLASH} =1.18 kΩ ±1%		±5	±10	%
	Current mirror ratio			1:300		

Backlight Drivers

LP3954 has 2 independent backlight drivers. Both drivers are regulated constant current sinks. LED current for both LED banks (WLED1...4 and WLED5...6) are controlled by 8-bit current mode DACs with 0.1 mA step.

WLED1...4 and WLED5...6 can be also controlled with one DAC for better matching allowing the use of larger displays having up to 6 white LEDs in parallel.

Display configuration is controlled with DISPL bit as shown below.

DISPL	Configuration	Matching
0	Main display up to 4 LEDs Sub display up to 2 LEDs	Good btw WLED1...4 Good btw WLED5...6
1	Large display up to 6 LEDs	Good btw WLED 1...6

Display backlight enables		
EN_W1-4	1	WLED1-4 enabled
	0	WLED1-4 disabled
EN_W5-6	1	WLED5-6 enabled
	0	WLED5-6 disabled

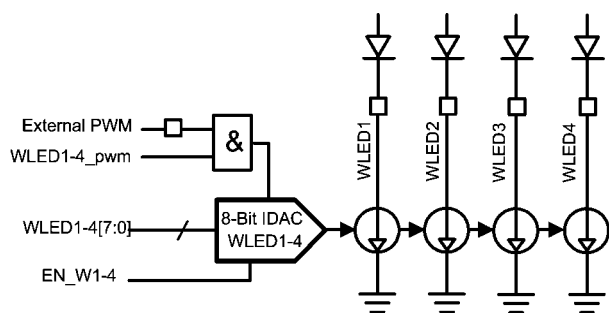

Main display up to 4 LEDs (WLED1...4)

20132235

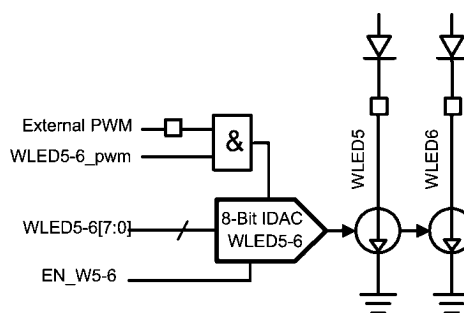

Sub display driver up to 2 LEDs (WLED5...6)

20132236

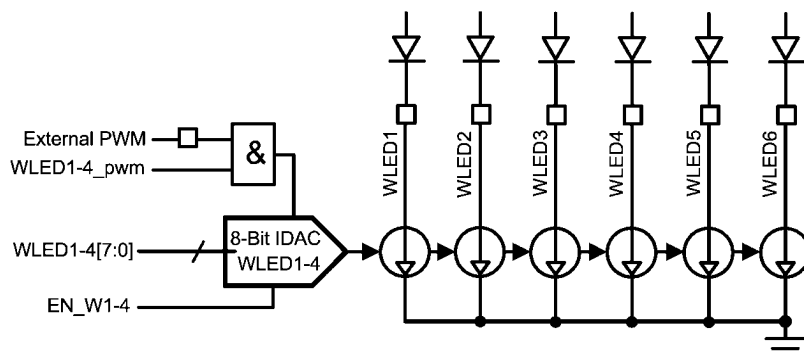

Main display up to 6 LEDs (WLED1...6) (DISPL=1)

20132237

BACKLIGHT DRIVER ELECTRICAL CHARACTERISTICS

Symbol	Parameter	Conditions	Min	Typical	Max	Units
I_{MAX}	Maximum Sink Current		21.3	25.5	29.4	mA
$I_{Leakage}$	Leakage Current	$V_{FB} = 5V$		0.03	1	μA
I_{WLED1}	WLED1 Current tolerance	I_{WLED1} set to 12.8mA (80H)	10.52 -18	12.8	14.78 +16	mA %
$I_{Match1-4}$	Sink Current Matching	$I_{SINK} = 13mA$, Between WLED1...4		0.2		%
$I_{Match5-6}$	Sink Current Matching	$I_{SINK} = 13mA$, Between WLED5...6		0.2		%
$I_{Match1-6}$	Sink Current Matching	$I_{SINK} = 13mA$, Between WLED1...6		0.3		%

Note: Matching is the maximum difference from the average.

ADJUSTMENT

WLED1-4[7:0] WLED5-6[7:0]	Driver current, ma (typical)
0000 0000	0
0000 0001	0.1
0000 0010	0.2
0000 0011	0.3
...	...
...	...
1111 1101	25.3
1111 1110	25.4
1111 1111	25.5

WLED Output Current vs. Voltage

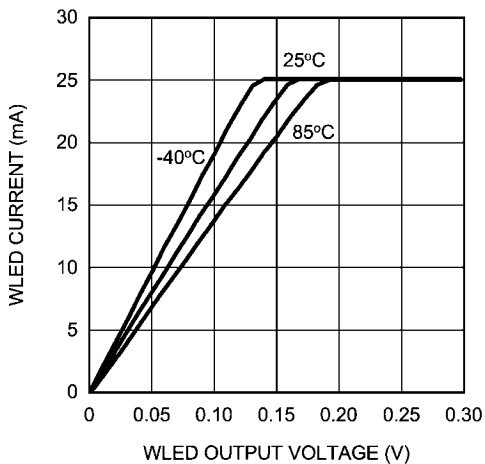

20132238

WLED dimming, SLOPE=0

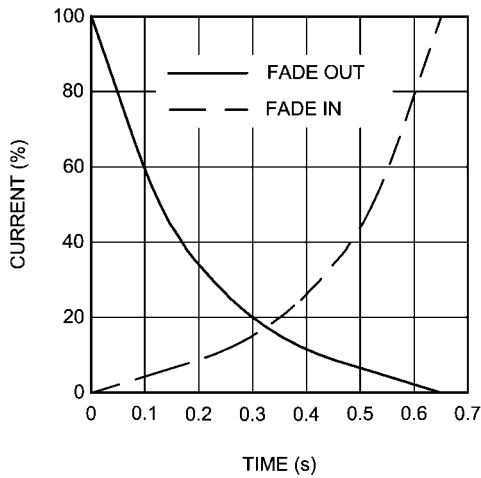

20132239

WLED dimming, SLOPE=1

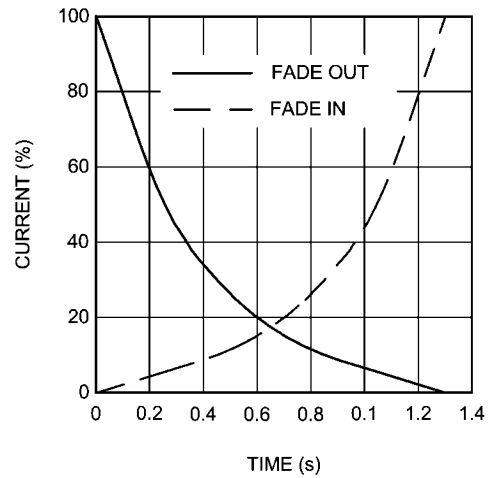

20132240

FADE IN / FADE OUT

LP3954 has an automatic fade in and out for main and sub backlight. The fade function is enabled with EN_FADE bit. The slope of the fade curve is set by the SLOPE bit. Fade control for main and sub display is set by FADE_SEL bit.

EN_FADE	0	Automatic fade disabled
	1	Automatic fade enabled
SLOPE	0	Fade execution time 1.3s
	1	Fade execution time 0.65s
FADE_SEL	0	Fade controls WLED1-4
	1	Fade controls WLED5-6

Note: if DISPL=1 and FADE_SEL=0, Fade effects to WLED1-6
Recommended fading sequence:

1. ASSUMPTION: Current WLED value in register
2. Set SLOPE
3. Set FADE_SEL
4. Set EN_FADE = 1
5. Set target WLED value
6. Fading will be done either within 0.5s or 1s based on Slope selection

Ambient Light and Temperature Measurement with LP3954

The Analog-to-Digital converter (ADC) in the Audio Synchronization block can be also used for ambient light measurement or temperature measurement.

The selection between these modes is controlled with input selector bits INPUT_SEL[1:0] as follows

INPUT_SEL[1:0]	Mode
00	Audio synchronization
01	Temperature measurement (voltage input)
10	Ambient light measurement (current input)
11	No input

AMBIENT LIGHT MEASUREMENT

The ambient light measurement requires only one external component: Ambient light sensor (photo transistor or diode). The ADC reads the current level at ASE pin and converts the result in digital word. User can read the ADC output from the ADC output register. The known ambient light condition allows user to set the backlight current to optimal level thus saving power especially in low light and bright sunlight condition.

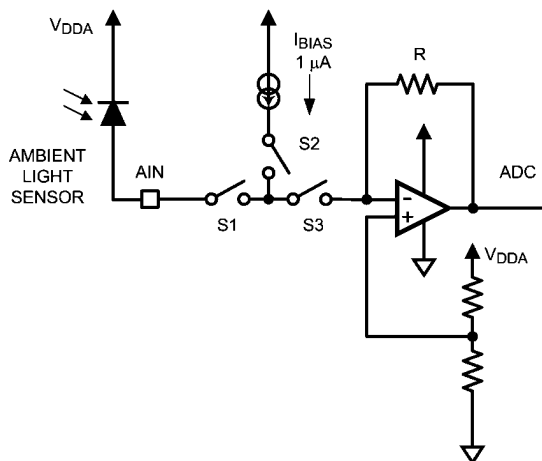

20132241

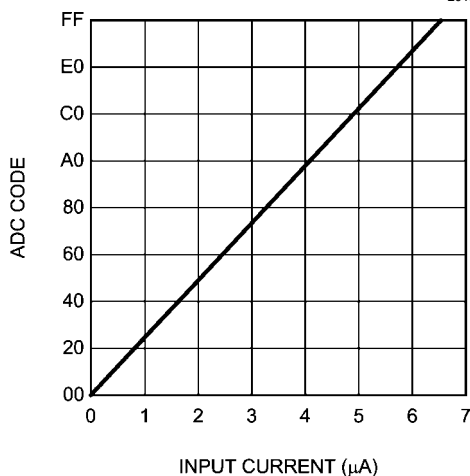

ADC Code vs Input Current in light measurement mode

20132264

TEMPERATURE MEASUREMENT

The temperature measurement requires two external components: resistor and thermistor (resistor that has known temperature vs resistance curve). The ADC reads the voltage level at ASE pin and converts the result in digital word. User can read the ADC output from register. The known temperature allows for example to monitor the temperature inside the display module and decrease the current level of the LEDs if temperature raises too high. This function may increase lifetime of LEDs in some applications.

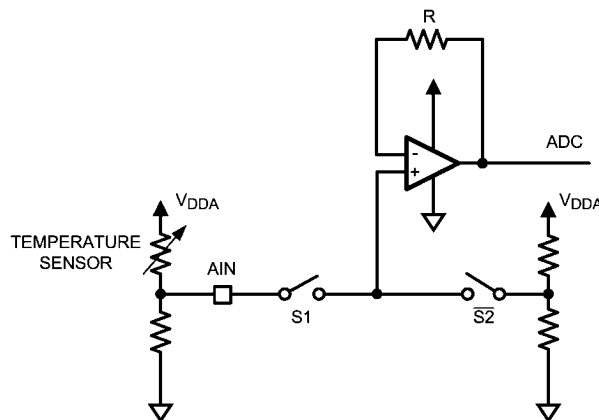

20132242

Temperature sensor connection example

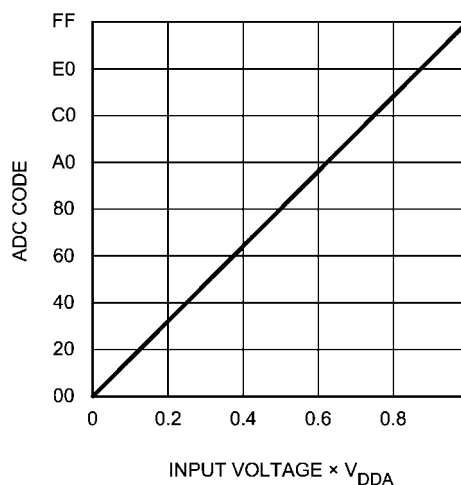

ADC Code vs Input Voltage in temperature measurement mode

20132263

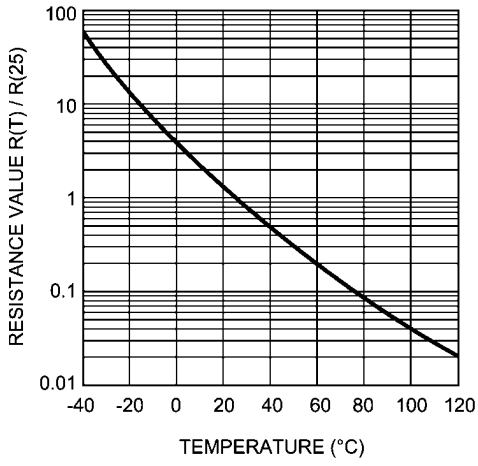

Example curve for thermistor

20132243

EXAMPLE TEMP SENSOR READING AT DIFFERENT TEMPERATURES ($R(25^{\circ}\text{C})=1\text{M}\Omega$)

T(°C)	R(MΩ)	Rt(MΩ)	V(ASE)
-40	1	60	2.7540984
0	1	4	2.24
25	1	1	1.4
60	1	0.2	0.4666667
100	1	0.04	0.1076923

7V Shielding

To shield LP3954 from high input voltages 6...7.2V the use of external 2.8V LDO is required. This 2.8V voltage protects internally the device against high voltage condition. The recommended connection is as shown in the picture below. Internally both logic and analog circuitry works at 2.8V supply voltage. Both supply voltage pins should have separate filtering capacitors.

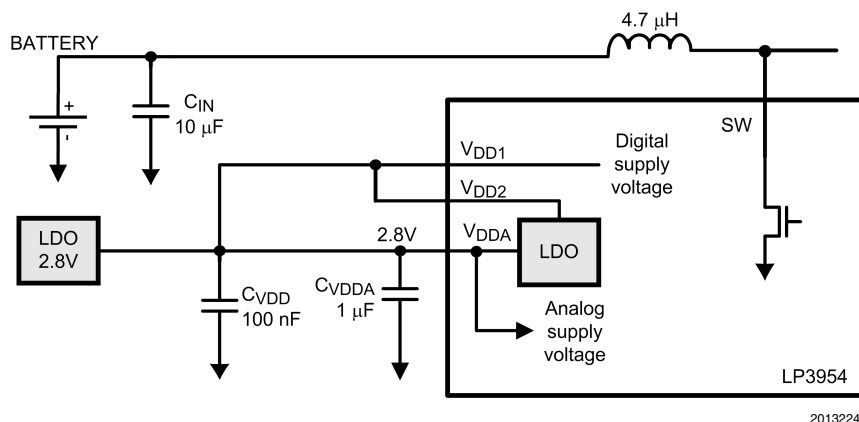

In cases where high voltage is not an issue the connection is as shown below

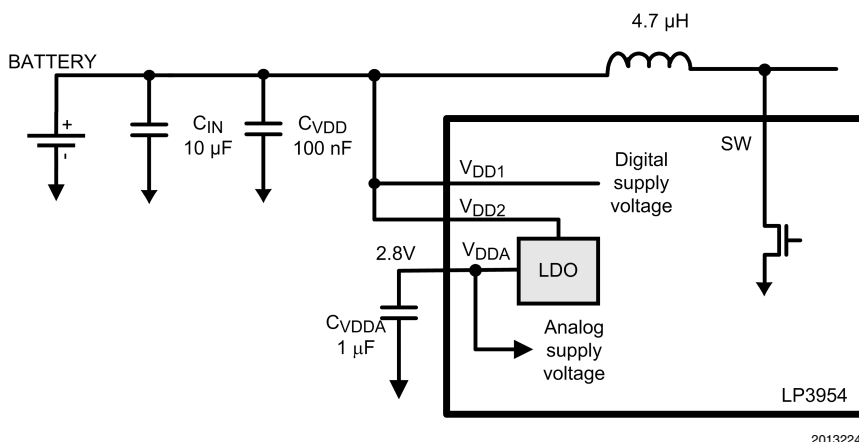

Logic Interface Characteristics

($1.65V \leq V_{DDIO} \leq V_{DD1,2}V$) (Unless otherwise noted).

Symbol	Parameter	Conditions	Min	Typ	Max	Units
LOGIC INPUTS SS, SI, SCK/SCL, SYNC/PWM, IF_SEL, EN_FLASH						
V_{IL}	Input Low Level				$0.2 \times V_{DDIO}$	V
V_{IH}	Input High Level		$0.8 \times V_{DDIO}$			V
I_I	Logic Input Current		-1.0		1.0	μA
f_{SCL}	Clock Frequency	I ² C Mode			400	kHz
		SPI Mode, $V_{DDIO} > 1.8V$			13	MHz
		SPI Mode, $1.65V \leq V_{DDIO} < 1.8V$			5	MHz
LOGIC OUTPUT SO						
V_{OL}	Output Low Level	$I_{SO} = 3\text{ mA}$ $V_{DDIO} > 1.8V$		0.3	0.5	V
		$I_{SO} = 2\text{ mA}$ $1.65V \leq V_{DDIO} < 1.8V$		0.3	0.5	
V_{OH}	Output High Level	$I_{SO} = -3\text{ mA}$ $V_{DDIO} > 1.8V$	$V_{DDIO} - 0.5$	$V_{DDIO} - 0.3$		V
		$I_{SO} = -2\text{ mA}$ $1.65V \leq V_{DDIO} < 1.8V$	$V_{DDIO} - 0.5$	$V_{DDIO} - 0.3$		
I_L	Output Leakage Current	$V_{SO} = 2.8V$			1.0	μA
LOGIC OUTPUT SDA						
V_{OL}	Output Low Level	$I_{SDA} = 3\text{ mA}$		0.3	0.5	V

Control Interface

The LP3954 supports two different interface modes:

User can define the serial interface by IF_SEL pin. IF_SEL=0 selects the I²C mode.

- SPI interface (4 wire, serial)
- I²C compatible interface (2 wire, serial)

SPI INTERFACE

LP3954 is compatible with SPI serial bus specification and it operates as a slave. The transmission consists of 16-bit Write and Read Cycles. One cycle consists of 7 Address bits, 1 Read/Write (RW) bit and 8 Data bits. RW bit high state defines a Write Cycle and low defines a Read Cycle. SO output is normally in high-impedance state and it is active only when Data is sent out during a Read Cycle. A pull-up resistor may be needed in SO line if a floating logic signal can cause unintended current consumption in the input circuits where SO is connected. The Address and Data are transmitted MSB first. The Slave Select signal SS must be low during the Cycle transmission. SS resets the interface when high and it has to be taken high between successive Cycles. Data is clocked in on the rising edge of the SCK clock signal, while data is clocked out on the falling edge of SCK.

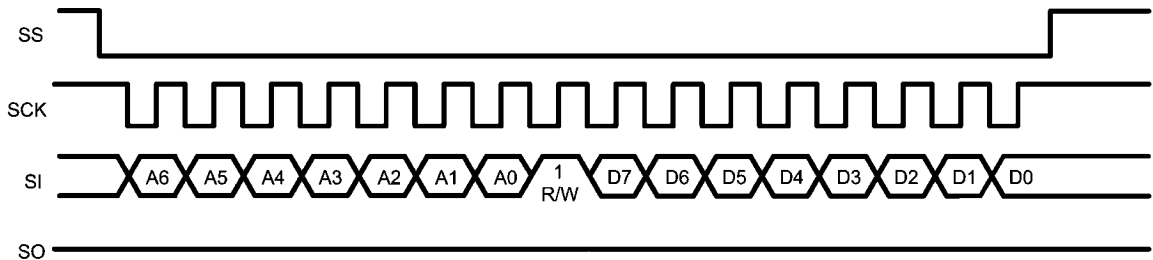

SPI Write Cycle

20132246

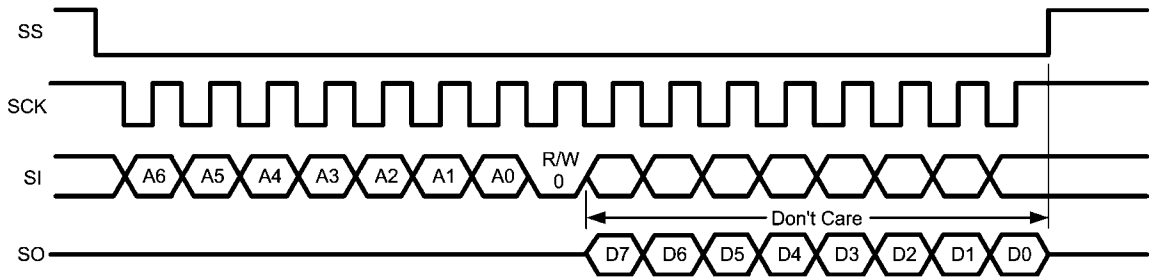

SPI Read Cycle

20132247

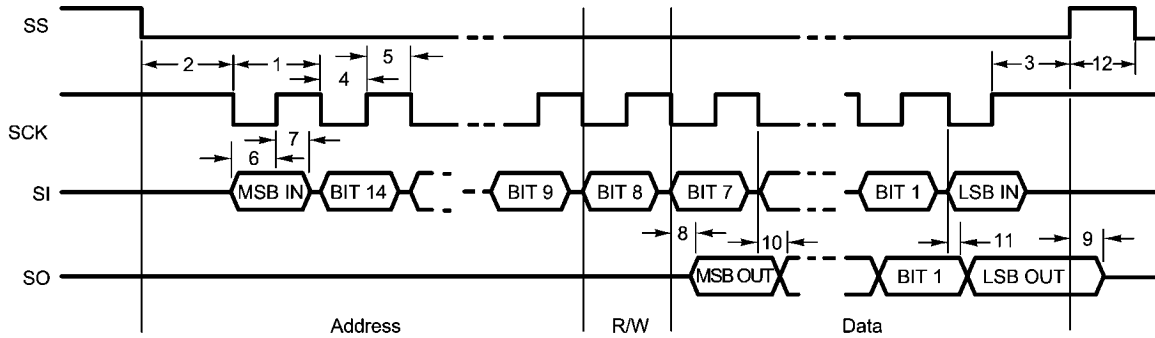

SPI Timing Diagram

20132248

SPI Timing Parameters

$V_{DD} = V_{DD_IO} = 2.775V$

Symbol	Parameter	Limit		Units
		Min	Max	
1	Cycle Time	70		ns
2	Enable Lead Time	35		ns
3	Enable Lag Time	35		ns
4	Clock Low Time	35		ns
5	Clock High Time	35		ns
6	Data Setup Time	20		ns
7	Data Hold Time	0		ns
8	Data Access Time		20	ns
9	Disable Time		10	ns
10	Data Valid		20	ns
11	Data Hold Time	0		ns

Note: Data guaranteed by design.

I²C COMPATIBLE INTERFACE

I²C Signals

In I²C mode the LP3954 pin SCK is used for the I²C clock SCL and the pin SS is used for the I²C data signal SDA. Both these signals need a pull-up resistor according to I²C specification. SI pin is the address select pin. I²C address for LP3954 is 54h when SI = 0 and 55h when SI = 1. Unused pin SO can be left unconnected.

I²C Data Validity

The data on SDA line must be stable during the HIGH period of the clock signal (SCL). In other words, state of the data line can only be changed when CLK is LOW.

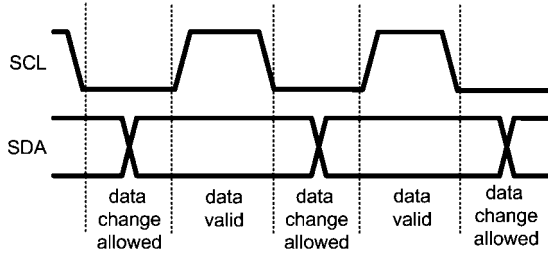

I²C Signals: Data Validity

20132249

I²C Start and Stop Conditions

START and STOP bits classify the beginning and the end of the I²C session. START condition is defined as SDA signal transitioning from HIGH to LOW while SCL line is HIGH. STOP condition is defined as the SDA transitioning from LOW to HIGH while SCL is HIGH. The I²C master always generates START and STOP bits. The I²C bus is considered to be busy after START condition and free after STOP condition. During data transmission, I²C master can generate repeated START conditions. First START and repeated START conditions are equivalent, function-wise.

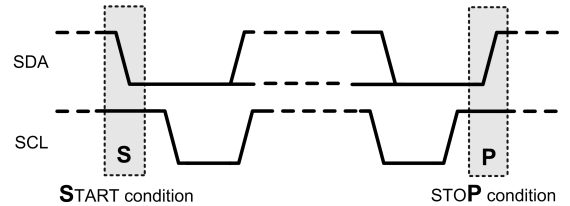

20132250

Transferring Data

Every byte put on the SDA line must be eight bits long, with the most significant bit (MSB) being transferred first. Each byte of data has to be followed by an acknowledge bit. The acknowledge related clock pulse is generated by the master. The transmitter releases the SDA (HIGH) during the acknowledge clock pulse. The receiver must pull down the SDA line during the 9th clock pulse, signifying an acknowledge. A receiver which has been addressed must generate an acknowledge after each byte has been received.

After the START condition, the I²C master sends a chip address. This address is seven bits long followed by an eighth bit which is a data direction bit (R/W). The LP3954 address is 54h or 55H as selected with SI pin. For the eighth bit, a "0" indicates a WRITE and a "1" indicates a READ. The second byte selects the register to which the data will be written. The third byte contains data to write to the selected register.

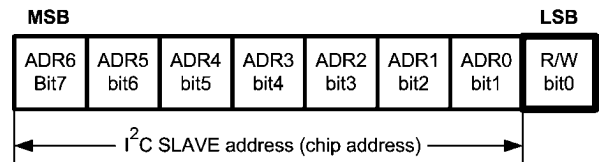

20132251

I²C Chip Address

Register changes take an effect at the SCL rising edge during the last ACK from slave.

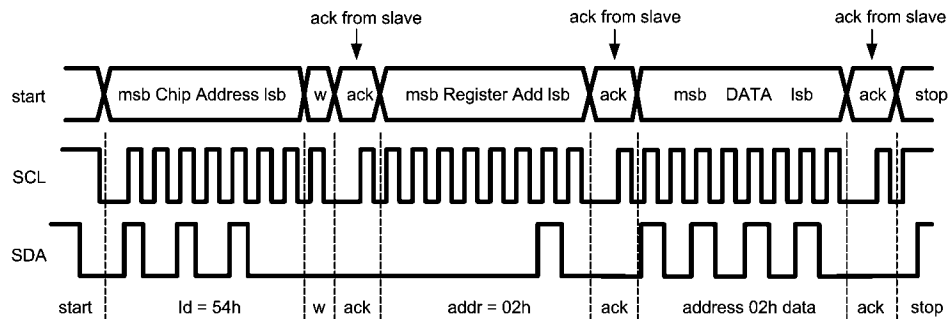

20132252

w = write (SDA = "0")
 r = read (SDA = "1")
 ack = acknowledge (SDA pulled down by either master or slave)
 rs = repeated start
 id = 7-bit chip address, 54h (SI=0) or 55h (SI=1) for LP3954.

I²C Write Cycle

When a READ function is to be accomplished, a WRITE function must precede the READ function, as shown in the Read Cycle waveform.

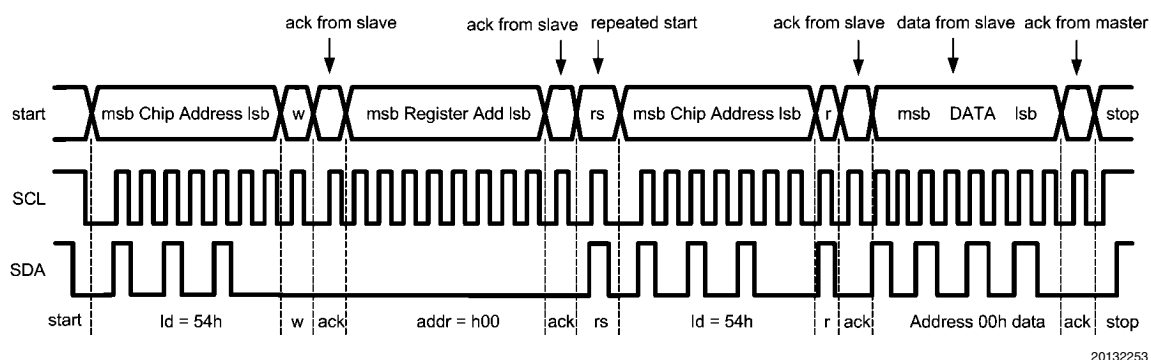

I²C Read Cycle

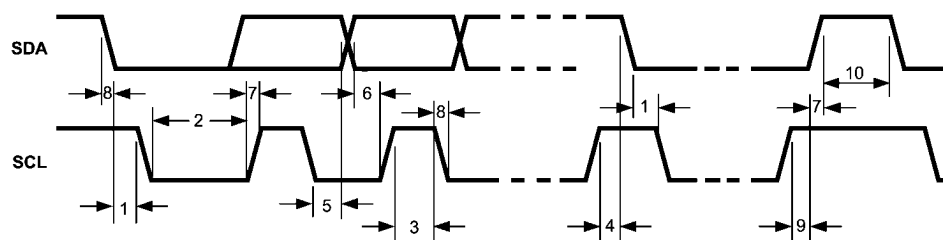

I²C Timing Diagram

I²C Timing Parameters ($V_{DD1,2} = 3.0$ to $4.5V$, $V_{DD_IO} = 1.65V$ to $V_{DD1,2}$)

Symbol	Parameter	Limit		Units
		Min	Max	
1	Hold Time (repeated) START Condition	0.6		μs
2	Clock Low Time	1.3		μs
3	Clock High Time	600		ns
4	Setup Time for a Repeated START Condition	600		ns
5	Data Hold Time (Output direction, delay generated by LP3954)	300	900	ns
5	Data Hold Time (Input direction, delay generated by the Master)	0	900	ns
6	Data Setup Time	100		ns
7	Rise Time of SDA and SCL	$20+0.1C_b$	300	ns
8	Fall Time of SDA and SCL	$15+0.1C_b$	300	ns
9	Set-up Time for STOP condition	600		ns
10	Bus Free Time between a STOP and a START Condition	1.3		μs
C_b	Capacitive Load for Each Bus Line	10	200	pF

NOTE: Data guaranteed by design

Autoincrement mode is available, with this possible read or write few byte with autoincreasing addresses, but LP3954 has holes in address register map, and is recommended to use autoincrement mode only for the pattern command registers.

Recommended External Components

OUTPUT CAPACITOR, C_{OUT}

The output capacitor C_{OUT} directly affects the magnitude of the output ripple voltage. In general, the higher the value of C_{OUT} , the lower the output ripple magnitude. Multilayer ceramic capacitors with low ESR are the best choice. At the lighter loads, the low ESR ceramics offer a much lower V_{out} ripple than the higher ESR tantalums of the same value. At the higher loads, the ceramics offer a slightly lower V_{out} ripple magnitude than the tantalums of the same value. However, the dv/dt of the V_{out} ripple with the ceramics is much lower than the tantalums under all load conditions. Capacitor voltage rating must be sufficient, 10V or greater is recommended.

Some ceramic capacitors, especially those in small packages, exhibit a strong capacitance reduction with the increased applied voltage. The capacitance value can fall to below half of the nominal capacitance. Too low output capacitance will increase the noise and it can make the boost converter unstable.

INPUT CAPACITOR, C_{IN}

The input capacitor C_{IN} directly affects the magnitude of the input ripple voltage and to a lesser degree the V_{OUT} ripple. A higher value C_{IN} will give a lower V_{IN} ripple. Capacitor voltage rating must be sufficient, 10V or greater is recommended.

LIST OF RECOMMENDED EXTERNAL COMPONENTS

Symbol	Symbol explanation	Value	Unit	Type
C_{VDD1}	C between VDD1 and GND	100	nF	Ceramic, X7R / X5R
C_{VDD2}	C between VDD2 and GND	100	nF	Ceramic, X7R / X5R
C_{VDDIO}	C between VDDIO and GND	100	nF	Ceramic, X7R / X5R
C_{VDDA}	C between VDDA and GND	1	μ F	Ceramic, X7R / X5R
C_{OUT}	C between FB and GND	10	μ F	Ceramic, X7R / X5R, 10V
C_{IN}	C between battery voltage and GND	10	μ F	Ceramic, X7R / X5R
L_{BOOST}	L between SW and V_{BAT} at 2 MHz	4.7	μ H	Shielded, low ESR, Isat 1A
C_{VREF}	C between V_{REF} and GND	100	nF	Ceramic, X7R
C_{VDDIO}	C between V_{DDIO} and GND	100	nF	Ceramic, X7R
R_{FLASH}	R between I_{FLASH} and GND	1.2	k Ω	$\pm 1\%$
R_{RBG}	R between I_{RGB} and GND	5.6	k Ω	$\pm 1\%$
R_{RT}	R between I_{RT} and GND	82	k Ω	$\pm 1\%$
D_{OUT}	Rectifying Diode (V_f @ maxload)	0.3	V	Schottky diode
C_{ASE}	C between Audio input and ASE	100	nF	Ceramic, X7R / X5R
LEDs				User defined
D_{LIGHT}	Light Sensor			TDK BSC2015

OUTPUT DIODE, D_{OUT}

A Schottky diode should be used for the output diode. To maintain high efficiency the average current rating of the schottky diode should be larger than the peak inductor current (1A). Schottky diodes with a low forward drop and fast switching speeds are ideal for increasing efficiency in portable applications. Choose a reverse breakdown of the schottky diode larger than the output voltage. Do not use ordinary rectifier diodes, since slow switching speeds and long recovery times cause the efficiency and the load regulation to suffer.

INDUCTOR, L_1

The LP3954's high switching frequency enables the use of the small surface mount inductor. A 4.7 μ H shielded inductor is suggested for 2 MHz operation, 10 μ H should be used at 1 MHz. The inductor should have a saturation current rating higher than the peak current it will experience during circuit operation (1A). Less than 300 m Ω ESR is suggested for high efficiency. Open core inductors cause flux linkage with circuit components and interfere with the normal operation of the circuit. This should be avoided. For high efficiency, choose an inductor with a high frequency core material such as ferrite to reduce the core losses. To minimize radiated noise, use a toroid, pot core or shielded core inductor. The inductor should be connected to the SW pin as close to the IC as possible.

Application Examples

EXAMPLE 1

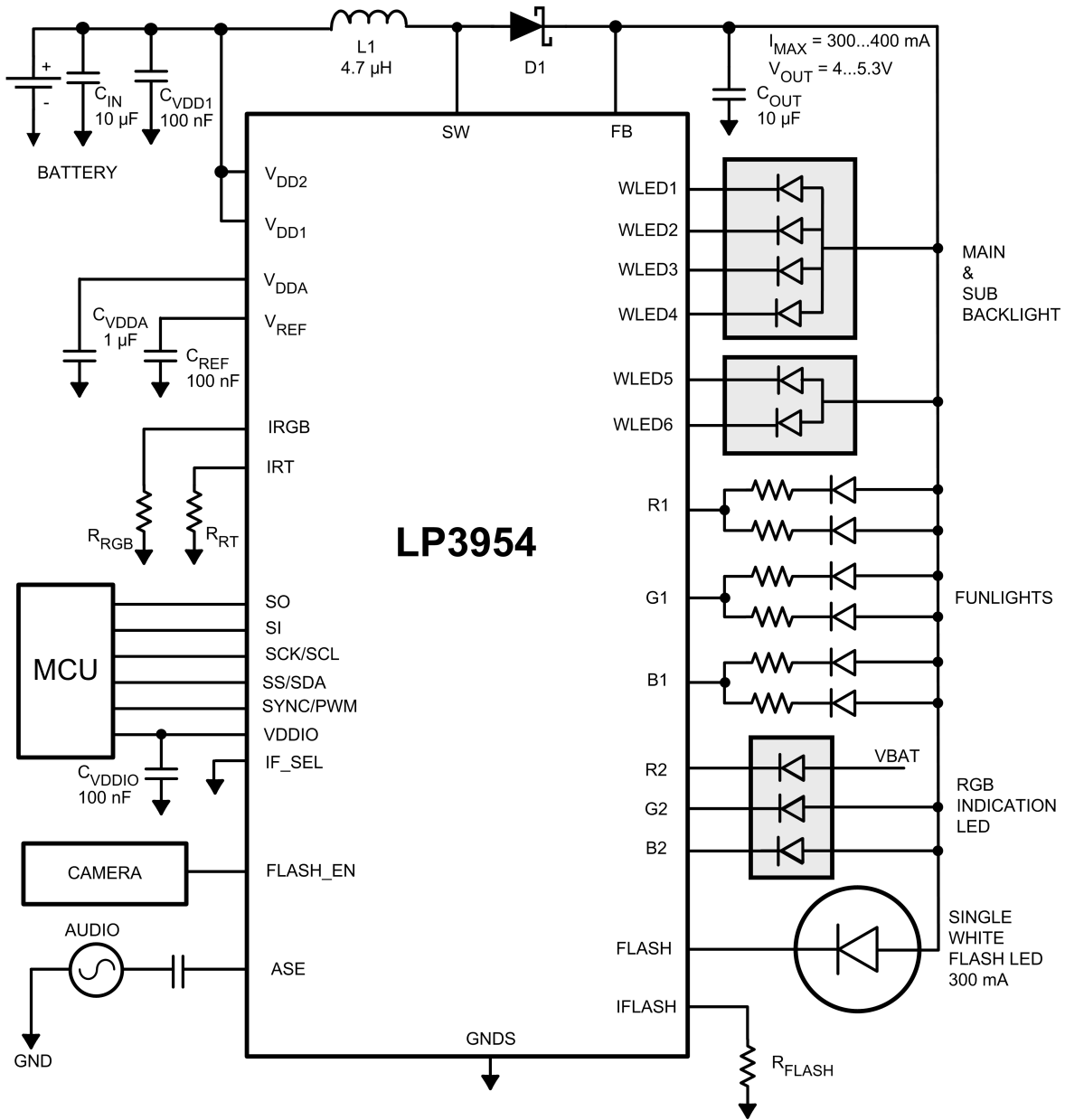

20132255

- MAIN BACKLIGHT
- SUB BACKLIGHT
- AUDIO SYNCHRONIZED FUNLIGHTS
- RGB INDICATION LIGHT
- FLASH LED

FLIP PHONE

EXAMPLE 2

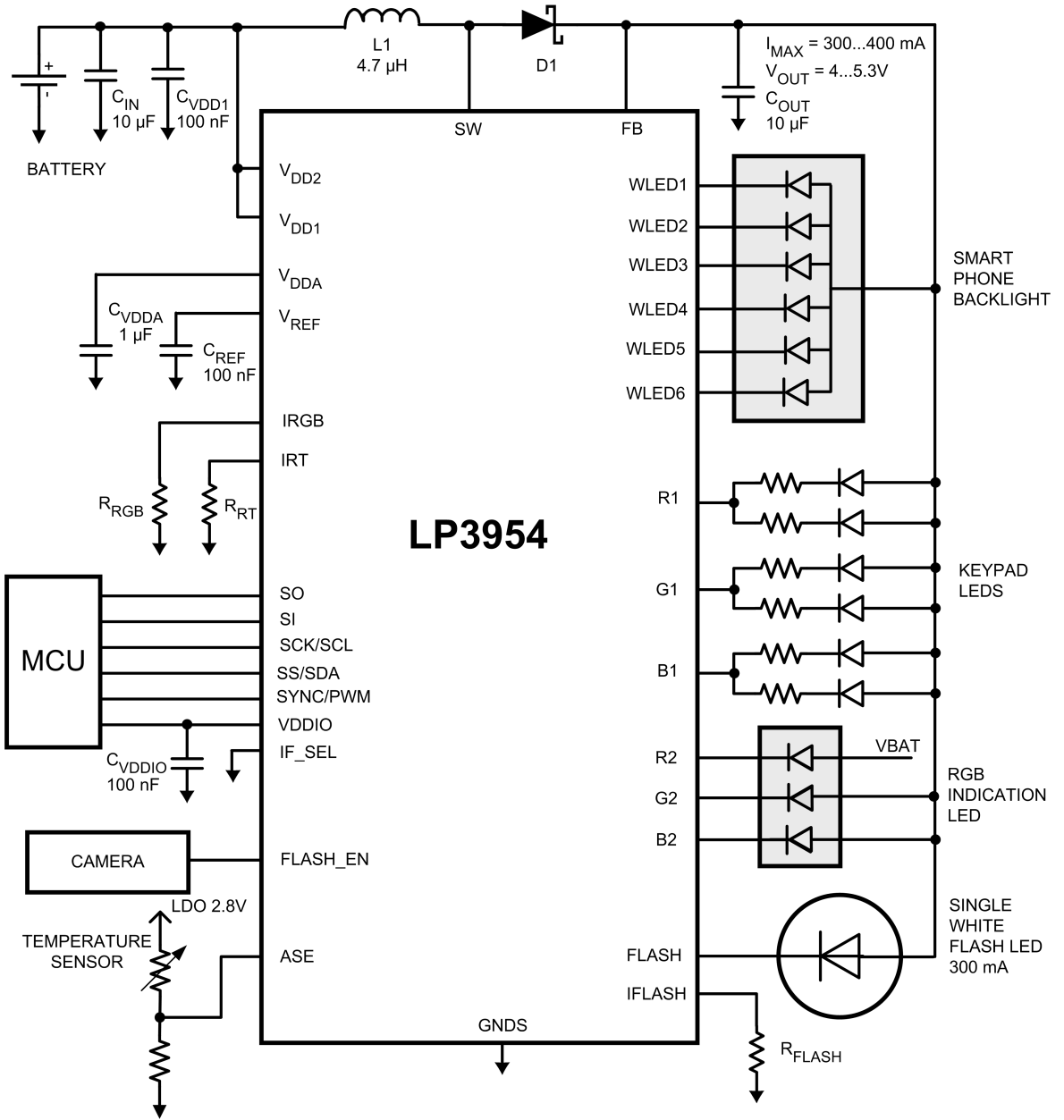

20132256

- 6 WHITE LED BACKLIGHT
- KEY PAD LIGHTS
- RGB INDICATION LED
- WHITE SINGLE LED FLASH
- TEMPERATURE SENSOR

SMART PHONE

EXAMPLE 3

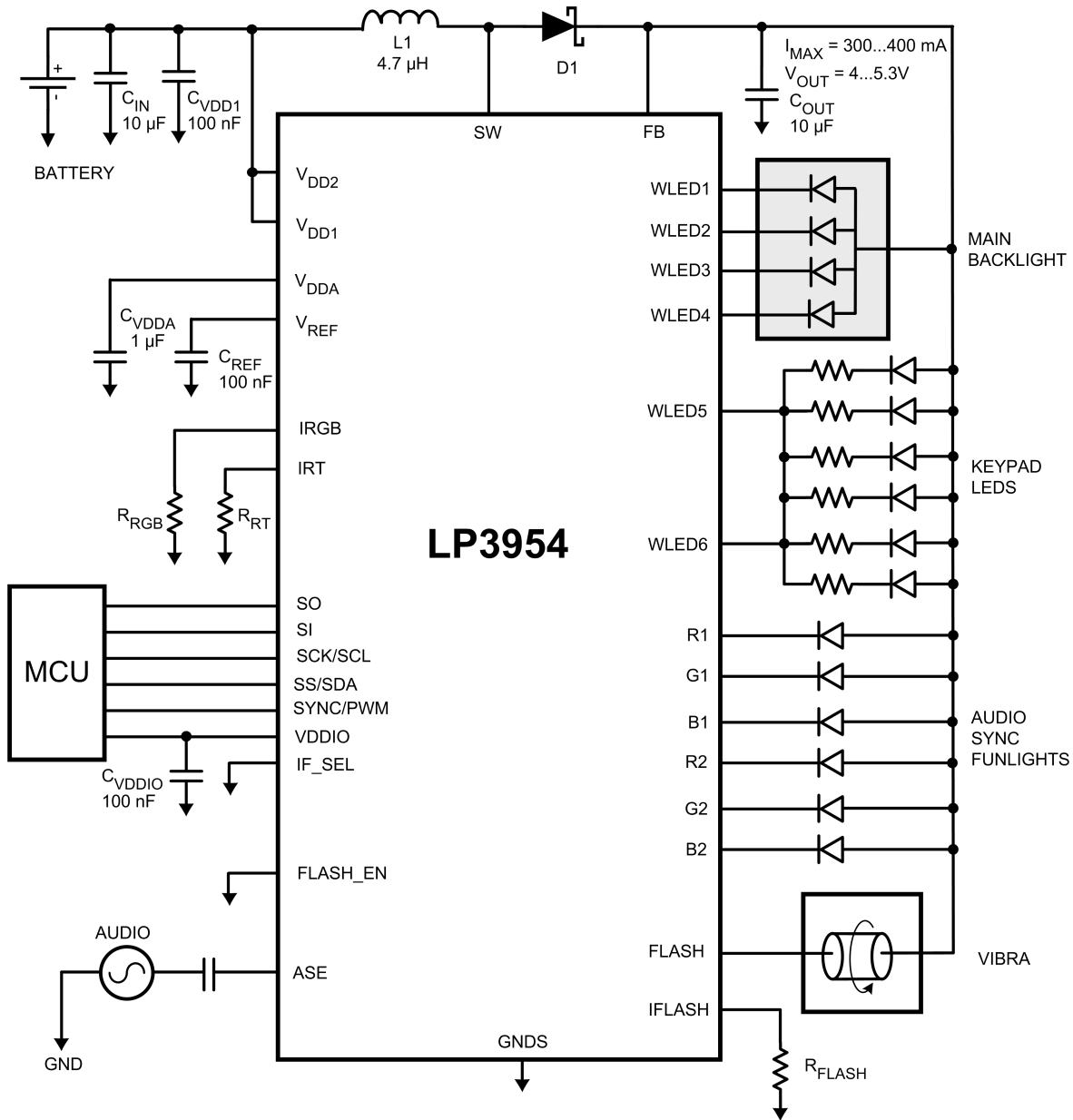

20132257

- MAIN BACKLIGHT
- KEYPAD LIGHTS
- AUDIO SYNCHRONIZED FUNLIGHTS
- VIBRA

CANDYBAR PHONE

EXAMPLE 4

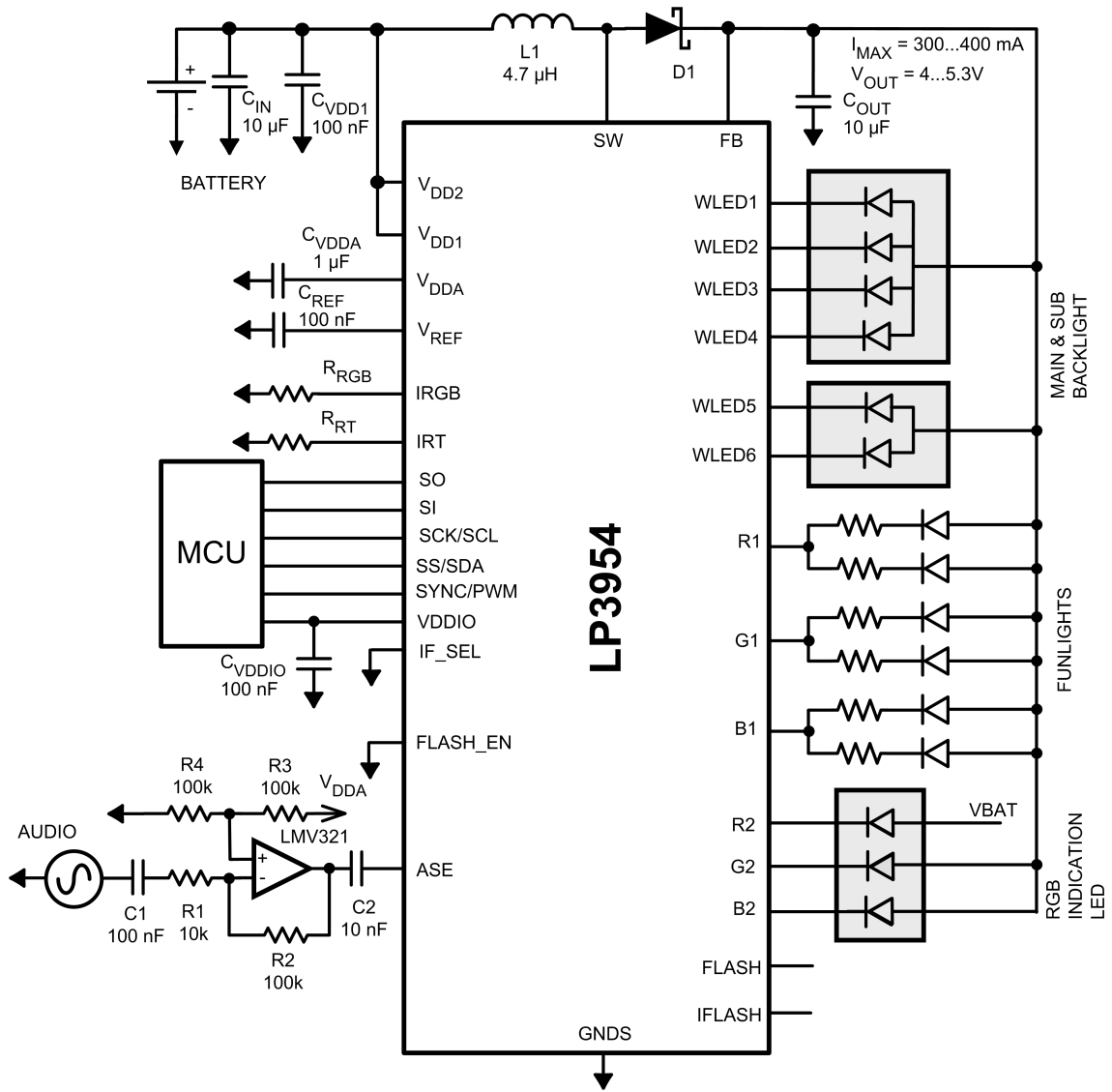

20132265

- MAIN BACKLIGHT
- SUB BACKLIGHT
- AUDIO SYNCHRONIZED FUNLIGHTS
- RGB INDICATION LIGHT

There may be cases where the audio input signal going into the LP3954 is too weak for audio synchronization. This figure presents a single-supply inverting amplifier connected to the ASE input for audio signal amplification. The amplification is +20 dB, which is well enough for 20 mVp-p audio signal. Because the amplifier (LMV321) is operating in single supply voltage, a voltage divider using R3 and R4 is implemented to bias the amplifier so the input signal is within the input common-mode voltage range of the amplifier. The capacitor C1 is placed between the inverting input and resistor R1 to block the DC signal going into the audio signal source. The values of R1 and C1 affect the cutoff frequency, $f_c = 1/(2 \cdot \pi \cdot R1 \cdot C1)$, in this case it is around 160 Hz. As a result, the LMV321 output signal is centered around mid-supply, that is $V_{DDA}/2$. The output can swing to both rails, maximizing the signal-to-noise ratio in a low voltage system

USING EXTRA AMPLIFIER

EXAMPLE 5

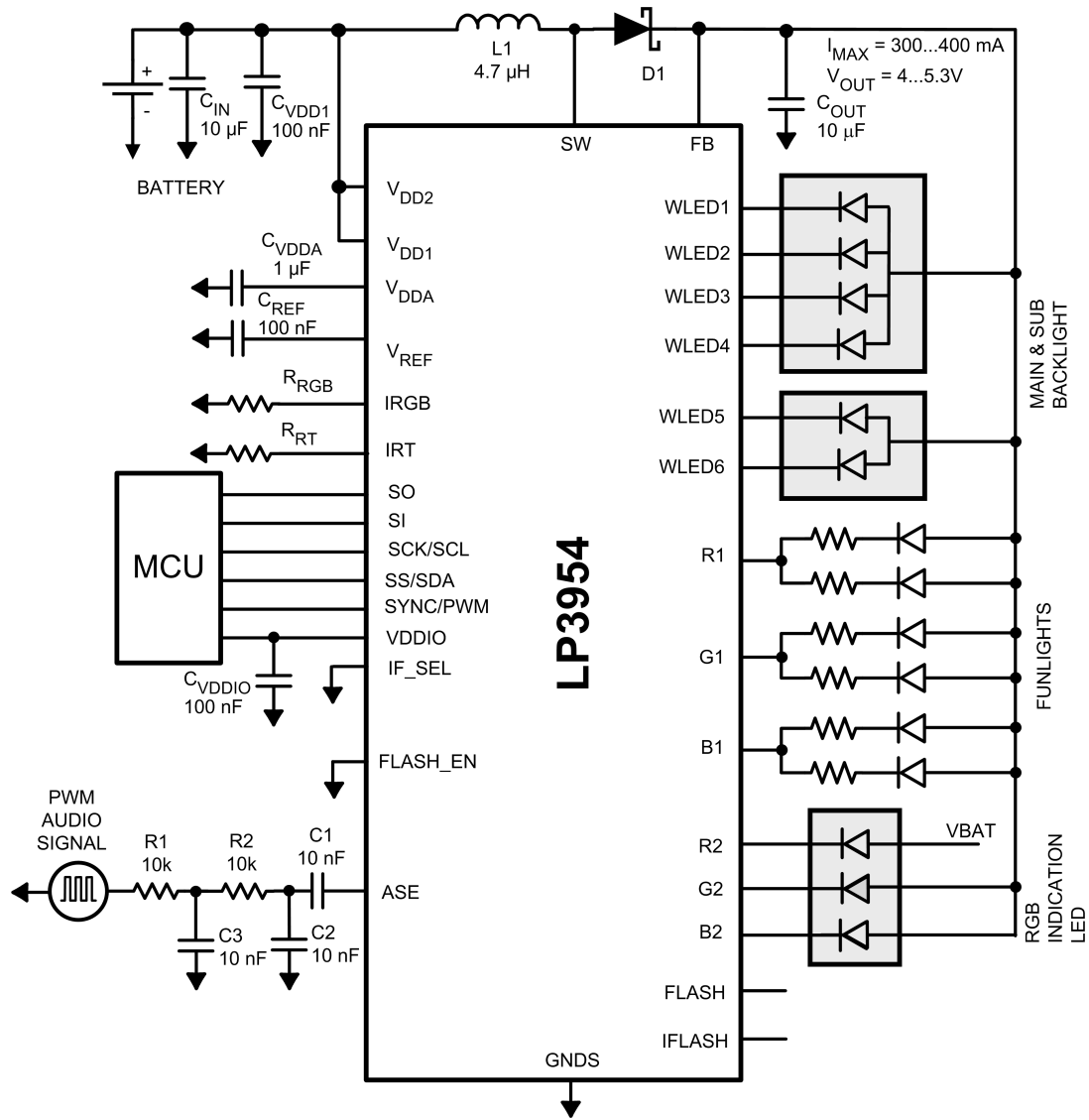

20132269

- MAIN BACKLIGHT
- SUB BACKLIGHT
- AUDIO SYNCHRONIZED FUNLIGHTS
- RGB INDICATION LIGHT

Here, a second order RC-filter is used on the ASE input to convert a PWM signal to an analog waveform.

USING PWM SYGNAL

More application information is available in the document "LP3954 Evaluation Kit".

LP3954 Control Register Names and Default Values

ADDR (HEX)	REGISTER	D7	D6	D5	D4	D3	D2	D1	D0
00	RGB Ctrl	cc_rgb1 1	cc_rgb2 1	r1sw 0	g1sw 0	b1sw 0	r2sw 0	g2sw 0	b2sw 0
07	Ext. PWM control	wled1_4_pwm 0	wled5_6_pwm 0	r1_pwm 0	g1_pwm 0	b1_pwm 0	r2_pwm 0	g2_pwm 0	b2_pwm 0
08	WLED control	slope 0		fade_sel 0	en_fade 0	displ 0	en_w1_4 0	en_w5_6 0	
09	WLED1-4	wled1_4[7:0]							
0A	WLED5-6	wled5_6[7:0]							
0B	Enables	pwm_sync 0	nstby 0	en_boost 0	en_autoload 1	en_rgb_sel[1:0] 0			
0C	ADC output	data[7:0]							
0D	Boost output	boost[7:0]							
0E	Boost_freq	freq_sel[2:0]							
10	HC_Flash	hc_pwm 0	fl_t[1:0] 0	hc[1:0] 1	en_hcflash 1				
11	Pattern gen ctrl	rgb_start 0		loop 0	log 0				
12	RGB1 max current	ir1[1:0] 0		ig1[1:0] 0	ib1[1:0] 0				
13	RGB2 max current	ir2[1:0] 0		ig2[1:0] 0	ib2[1:0] 0				
2A	audio sync CTRL1	gain_sel[2:0] 0		sync_mode 0	en_agc 0	en_sync 0	input_sel[1:0] 1		
2B	audio sync CTRL2	en_avg 0		mode_ctrl[1:0] 0	speed_ctrl[1:0] 0				

ADDR (HEX)	REGISTER	D7	D6	D5	D4	D3	D2	D1	D0
50	Command 1A	r[2:0]		g[2:0]		cet[3:2]			
		0	0	0	0	0	0	0	0
51	Command 1B	cet[1:0]		b[2:0]		tt[2:0]			
		0	0	0	0	0	0	0	0
52	Command 2A	r[2:0]		g[2:0]		cet[3:2]			
		0	0	0	0	0	0	0	0
53	Command 2B	cet[1:0]		b[2:0]		tt[2:0]			
		0	0	0	0	0	0	0	0
54	Command 3A	r[2:0]		g[2:0]		cet[3:2]			
		0	0	0	0	0	0	0	0
55	Command 3B	cet[1:0]		b[2:0]		tt[2:0]			
		0	0	0	0	0	0	0	0
56	Command 4A	r[2:0]		g[2:0]		cet[3:2]			
		0	0	0	0	0	0	0	0
57	Command 4B	cet[1:0]		b[2:0]		tt[2:0]			
		0	0	0	0	0	0	0	0
58	Command 5A	r[2:0]		g[2:0]		cet[3:2]			
		0	0	0	0	0	0	0	0
59	Command 5B	cet[1:0]		b[2:0]		tt[2:0]			
		0	0	0	0	0	0	0	0
5A	Command 6A	r[2:0]		g[2:0]		cet[3:2]			
		0	0	0	0	0	0	0	0
5B	Command 6B	cet[1:0]		b[2:0]		tt[2:0]			
		0	0	0	0	0	0	0	0
5C	Command 7A	r[2:0]		g[2:0]		cet[3:2]			
		0	0	0	0	0	0	0	0
5D	Command 7B	cet[1:0]		b[2:0]		tt[2:0]			
		0	0	0	0	0	0	0	0
5E	Command 8A	r[2:0]		g[2:0]		cet[3:2]			
		0	0	0	0	0	0	0	0
5F	Command 8B	cet[1:0]		b[2:0]		tt[2:0]			
		0	0	0	0	0	0	0	0
60	Reset	Writing any data to Reset Register resets LP3954							

LP3954 Registers

REGISTER BIT EXPLANATIONS

Each register is shown with a key indicating the accessibility of the each individual bit, and the initial condition:

Register Bit Accessibility and Initial Condition

Key	Bit Accessibility
rw	Read/write
r	Read only
-0,-1	Condition after POR

RGB CTRL (00H) – RGB LEDS CONTROL REGISTER

D7	D6	D5	D4	D3	D2	D1	D0
cc_rgb1	cc_rgb2	r1sw	g1sw	b1sw	r2sw	g2sw	b2sw
rw-1	rw-1	rw-0	rw-0	rw-0	rw-0	rw-0	rw-0

cc_rgb1	Bit 7	0 - R1, G1 and B1 are constant current sinks, current limited internally 1 - R1, G1 and B1 are switches, limit current with external ballast resistor
cc_rgb2	Bit 6	0 – R2, G2 and B2 are constant current sinks, current limited internally 1 – R2, G2 and B2 are switches, limit current with external ballast resistor
r1sw	Bit 5	0 – R1 disabled 1 – R1 enabled
g1sw	Bit 4	0 – G1 disabled 1 – G1 enabled
b1sw	Bit 3	0 – B1 disabled 1 – B1 enabled
r2sw	Bit 2	0 – R2 disabled 1 – R2 enabled
g2sw	Bit 1	0 – G2 disabled 1 – G2 enabled
b2sw	Bit 0	0 – B2 disabled 1 – B2 enabled

EXT_PWM_CONTROL (07H) – EXTERNAL PWM CONTROL REGISTER

D7	D6	D5	D4	D3	D2	D1	D0
wled1_4_pwm	wled5_6_pwm	r1_pwm	g1_pwm	b1_pwm	r2_pwm	g2_pwm	b2_pwm
rw-0	rw-0	rw-0	rw-0	rw-0	rw-0	rw-0	rw-0

wled1_4_pwm	Bit 7	0 – WLED1...WLED4 PWM control disabled 1 – WLED1...WLED4 PWM control enabled
wled5_6_pwm	Bit 6	0 – WLED5, WLED6 PWM control disabled 1 – WLED5, WLED6 PWM control enabled
r1_pwm	Bit 5	0 – R1 PWM control disabled 1 – R1 PWM control enabled
g1_pwm	Bit 4	0 – G1 PWM control disabled 1 – G1 PWM control enabled
b1_pwm	Bit 3	0 – RB PWM control disabled 1 – B1 PWM control enabled
r2_pwm	Bit 2	0 – R2 PWM control disabled 1 – R2 PWM control enabled
g2_pwm	Bit 1	0 – G2 PWM control disabled 1 – G2 PWM control enabled
b2_pwm	Bit 0	0 – B2 PWM control disabled 1 – B2 PWM control enabled

WLED CONTROL (08H) – WLED CONTROL REGISTER

D7	D6	D5	D4	D3	D2	D1	D0
		slope	fade_sel	en_fade	displ	en_w1_4	en_w5_6
r-0	r-0	rw-0	rw-0	rw-0	rw-0	rw-0	rw-0

slope	Bit 5	0 – fade execution time 1.3 sec 1 – fade execution time 0.65 sec
fade_sel	Bit 4	0 – fade control for WLED1... WLED4 1 – fade control for WLED5, WLED6
en_fade	Bit 3	0 – automatic fade disabled 1 – automatic fade enabled
displ	Bit 2	0 – WLED1-4 and WLED5-6 are controlled separately 1 – WLED1-4 and WLED5-6 are controlled with WLED1-4 controls
en_w1_4	Bit 1	0 – WLED1...WLED4 disabled 1 – WLED1...WLED4 enabled
en_w5_6	Bit 0	0 – WLED5,WLED6 disabled 1 – WLED5,WLED6 enabled

WLED1-4 (09H) – WLED1...WLED4 BRIGHTNESS CONTROL REGISTER

D7	D6	D5	D4	D3	D2	D1	D0
wled1_4[7:0]							
rw-0	rw-0	rw-0	rw-0	rw-0	rw-0	rw-0	rw-0

		Adjustment	
		wled1_4[7:0]	Typical driver current (ma)
wled1_4[7:0]	Bits 7-0	0000 0000	0
		0000 0001	0.1
		0000 0010	0.2
		0000 0011	0.3
		0000 0100	0.4
	
		1111 1101	25.3
		1111 1110	25.4
		1111 1111	25.5

WLED5-6 (0AH) – WLED5, WLED6 BRIGHTNESS CONTROL REGISTER

D7	D6	D5	D4	D3	D2	D1	D0
wled5_5[7:0]							
rw-0	rw-0	rw-0	rw-0	rw-0	rw-0	rw-0	rw-0

		Adjustment	
		wled5_6[7:0]	Typical driver current (ma)
wled5_6[7:0]	Bits 7-0	0000 0000	0
		0000 0001	0.1
		0000 0010	0.2
		0000 0011	0.3
		0000 0100	0.4
	
		1111 1101	25.3
		1111 1110	25.4
		1111 1111	25.5

ENABLES (0BH) – ENABLES REGISTER

D7	D6	D5	D4	D3	D2	D1	D0
pwm_sync	nstby	en_boost			en_autoload	rgb_sel[1:0]	
rw-0	rw-0	rw-0	r-0	r-0	rw-1	rw-0	rw-0

pwm_sync	Bit 7	0 – synchronization to external clock disabled 1 – synchronization to external clock enabled		
nstby	Bit 6	0 – LP3954 standby mode 1 – LP3954 active mode		
en_boost	Bit 5	0 – boost converter disabled 1 – boost converter enabled		
en_autoload	Bit 2	0 – internal boost converter active load off 1 – internal boost converter active load on		
rgb_sel[1:0]	Bits 1-0	Color LED control mode selection		
		rgb_sel[1:0]	Audio sync connected to	Pattern generator connected to
		00	none	RGB1 & RGB2
		01	RGB1	RGB2
		10	RGB2	RGB1
		11	RGB1 & RGB2	none

ADC_OUTPUT (0CH) – ADC DATA REGISTER

D7	D6	D5	D4	D3	D2	D1	D0
data[7:0]							
r-0	r-0	r-0	r-0	r-0	r-0	r-0	r-0

data[7:0]	Bits 7-0	Data register ADC (Audio input, light or temperature sensors)
------------------	----------	---

BOOST_OUTPUT (0DH) – BOOST OUTPUT VOLTAGE CONTROL REGISTER

D7	D6	D5	D4	D3	D2	D1	D0
Boost[7:0]							
rw-0	rw-0	rw-1	rw-1	rw-1	rw-1	rw-1	rw-1

Boost[7:0]	Bits 7-0	Adjustment	
		Boost[7:0]	Typical boost output (V)
		0000 0000	4.00
		0000 0001	4.25
		0000 0011	4.40
		0000 0111	4.55
		0000 1111	4.70
		0001 1111	4.85
		0011 1111	5.00 (default)
		0111 1111	5.15
		1111 1111	5.30

BOOST_FRQ (0EH) – BOOST FREQUENCY CONTROL REGISTER

D7	D6	D5	D4	D3	D2	D1	D0
					freq_sel[2:0]		
r-0	r-0	r-0	r-0	r-0	rw-1	rw-1	rw-1

freq_sel[2:0]	Bits 7-0	Adjustment	
		freq_sel[2:0]	Frequency
		1xx	2.00 MHz
		01x	1.67 MHz
		00x	1.00 MHz

HC_FLASH (10H) – HIGH CURRENT FLASH DRIVER CONTROL REGISTER

D7	D6	D5	D4	D3	D2	D1	D0
		hc_pwm	fl_t[1:0]		hc[1:0]		en_hcflash
r-0	r-0	rw-0	rw-0	rw-0	rw-0	rw-0	rw-0

hc_pwm	Bit 5	0 – PWM for high current flash driver disabled 1 – PWM for high current flash driver enabled	
fl_t[1:0]	Bits 4-3	Flash duration for high current driver	
		fl_t[1:0]	Typical flash duration
		00	200 ms
		01	400 ms
		10	600 ms
		11 – According EN_FLASH pin on duration	
hc[1:0]	Bits 2-1	Current control for high current flash driver	
		hc[1:0]	current
		00	$0.25 \times I_{MAX(FLASH)}$
		01	$0.50 \times I_{MAX(FLASH)}$
		10	$0.75 \times I_{MAX(FLASH)}$
		11 – $1.00 \times I_{MAX(FLASH)}$	
en_hcflash	Bit 0	0 – high current flash driver disabled 1 – high current flash driver enabled	

PATTERN_GEN_CTRL (11H) – PATTERN GENERATOR CONTROL REGISTER

D7	D6	D5	D4	D3	D2	D1	D0
					rgb_start	loop	log
r-0	r-0	r-0	r-0	r-0	rw-0	rw-0	rw-0

rgb_start	Bit 2	0 – Pattern generator disabled 1 – execution pattern starting from command 1
loop	Bit 1	0 – pattern generator loop disabled (single patter) 1 – pattern generator loop enabled (execute until stopped)
log	Bit 0	0 – color intensity mode 0 1 – color intensity mode 1

RGB1_MAX_CURRENT (12H) – RGB1 DRIVER INDIVIDUAL MAXIMUM CURRENT CONTROL REGISTER

D7	D6	D5	D4	D3	D2	D1	D0
		ir1[1:0]		ig1[1:0]		ib1[1:0]	
r-0	r-0	rw-0	rw-0	rw-0	rw-0	rw-0	rw-0

ir1[1:0]	Bits 5-4	Maximum current for R1 driver	
		ir1[2:0]	Maximum output current
		00	$0.25 \times I_{MAX}$
		01	$0.50 \times I_{MAX}$
		10	$0.75 \times I_{MAX}$
ig1[1:0]	Bits 3-2	Maximum current for G1 driver	
		ig2[1:0]	Maximum output current
		00	$0.25 \times I_{MAX}$
		01	$0.50 \times I_{MAX}$
		10	$0.75 \times I_{MAX}$
ib1[1:0]	Bits 1-0	Maximum current for B1 driver	
		ib1[1:0]	Maximum output current
		00	$0.25 \times I_{MAX}$
		01	$0.50 \times I_{MAX}$
		10	$0.75 \times I_{MAX}$
		11	$1.00 \times I_{MAX}$

RGB2_MAX_CURRENT (13H) – RGB2 DRIVER INDIVIDUAL MAXIMUM CURRENT CONTROL REGISTER

D7	D6	D5	D4	D3	D2	D1	D0
		ir2[1:0]		ig2[1:0]		ib2[1:0]	
rw-0	rw-0	rw-0	rw-0	rw-0	rw-0	rw-0	rw-0

		Maximum current for R2 driver	
ir2[1:0]	Bits 5-4	ir2[2:0]	Maximum output current
		00	$0.25 \times I_{MAX}$
		01	$0.50 \times I_{MAX}$
		10	$0.75 \times I_{MAX}$
		11	$1.00 \times I_{MAX}$
		Maximum current for G2 driver	
ig2[1:0]	Bits 3-2	ig2[1:0]	Maximum output current
		00	$0.25 \times I_{MAX}$
		01	$0.50 \times I_{MAX}$
		10	$0.75 \times I_{MAX}$
		11	$1.00 \times I_{MAX}$
		Maximum current for B2 driver	
ib2[1:0]	Bits 1-0	ib2[1:0]	Maximum output current
		00	$0.25 \times I_{MAX}$
		01	$0.50 \times I_{MAX}$
		10	$0.75 \times I_{MAX}$
		11	$1.00 \times I_{MAX}$

AUDIO_SYNC_CTRL1 (2AH) – AUDIO SYNCHRONIZATION AND ADC CONTROL REGISTER 1

D7	D6	D5	D4	D3	D2	D1	D0
gain_sel[2:0]			sync_mode	en_agc	en_sync	input_sel[1:0]	
rw-0	rw-0	rw-0	rw-0	rw-0	rw-0	rw-1	rw-1

gain_sel[2:0]	Bits 7-5	Input signal gain control	
		gain_sel[2:0]	gain, db
		000	0 (default)
		001	3
		010	6
		011	9
		100	12
		101	15
		110	18
		111	21
sync_mode	Bit 4	Input filter mode control 0 – Amplitude mode 1 – Frequency mode	
en_agc	Bit 3	0 – automatic gain control disabled 1 – automatic gain control enabled	
en_sync	Bit 2	0 – audio synchronization disabled 1 – audio synchronization enabled	
input_sel[1:0]	Bits 1-0	ADC input selector	
		input_sel[1:0]	Input
		00	Single ended input signal (ASE)
		01	Temperature measurement
		10	Ambient light measurement
		11	No input (default)

AUDIO_SYNC_CTRL2 (2BH) – AUDIO SYNCHRONIZATION AND ADC CONTROL REGISTER 2

D7	D6	D5	D4	D3	D2	D1	D0
			en_avg	mode_ctrl[1:0]		speed_ctrl[1:0]	
r-0	r-0	r-0	rw-0	rw-0	rw-0	rw-0	rw-0

en_avg	Bit 4	0 – averaging disabled 1 – averaging enabled	
mode_ctrl[1:0]	Bits 3-2	Filtering mode control	
speed_ctrl[1:0]	Bits 1-0	LEDs light response time to audio input	
		speed_ctrl[1:0]	Response
		00	FASTEST (default)
		01	FAST
		10	MEDIUM
		11	SLOW

PATTERN CONTROL REGISTERS

Command_[1:8]A – Pattern Control Register A							
D7	D6	D5	D4	D3	D2	D1	D0
r[2:0]			g[2:0]			cet[3:2]	
rw-0	rw-0	rw-0	rw-0	rw-0	rw-0	rw-0	rw-0

Command_[1:8]B – Pattern Control Register B							
D7	D6	D5	D4	D3	D2	D1	D0
cet[1:0]		b[2:0]			tt[2:0]		
rw-0	rw-0	rw-0	rw-0	rw-0	rw-0	rw-0	rw-0

r[2:0]	Bits 7-5A	Red color intensity		
		r[2:0]	current, %	
			log=0	log=1
		000	0xI _{MAX}	0xI _{MAX}
001	7%xI _{MAX}	1%xI _{MAX}		
010	14%xI _{MAX}	2%xI _{MAX}		
011	21%xI _{MAX}	4%xI _{MAX}		
100	32%xI _{MAX}	10%xI _{MAX}		
101	46%xI _{MAX}	21%xI _{MAX}		
110	71%xI _{MAX}	46%xI _{MAX}		
111	100%xI _{MAX}	100%xI _{MAX}		
* log bit is in pattern_gen_ctrl register				
g[2:0]	Bits 4-2A	Green color intensity		
		g[2:0]	current, %	
			log=0	log=1
		000	0xI _{MAX}	0xI _{MAX}
001	7%xI _{MAX}	1%xI _{MAX}		
010	14%xI _{MAX}	2%xI _{MAX}		
011	21%xI _{MAX}	4%xI _{MAX}		
100	32%xI _{MAX}	10%xI _{MAX}		
101	46%xI _{MAX}	21%xI _{MAX}		
110	71%xI _{MAX}	46%xI _{MAX}		
111	100%xI _{MAX}	100%xI _{MAX}		
* log bit is in pattern_gen_ctrl register				

cet[3:0]	Bits 1-0A 7-6B	Command execution time	
		cet[3:0]	CET duration, ms
		0000	197
		0001	393
		0010	590
		0011	786
		0100	983
		0101	1180
		0110	1376
		0111	1573
		1000	1769
		1001	1966
		1010	2163
		1011	2359
		1100	2556
		1101	2753
		1110	2949
		1111	3146

b[2:0]	Bits 5-3B	Blue color intensity		
		b[2:0]	current, %	
			log=0	log=1
		000	0×I _{MAX}	0×I _{MAX}
		001	7%×I _{MAX}	1%×I _{MAX}
		010	14%×I _{MAX}	2%×I _{MAX}
		011	21%×I _{MAX}	4%×I _{MAX}
		100	32%×I _{MAX}	10%×I _{MAX}
		101	46%×I _{MAX}	21%×I _{MAX}
		110	71%×I _{MAX}	46%×I _{MAX}
		111	100%×I _{MAX}	100%×I _{MAX}

* log bit is in pattern_gen_ctrl register

tt[2:0]	Bits 2-0B	Transition time	
		tt[2:0]	Transition time, ms
		000	0
		001	55
		010	110
		011	221
		100	442
		101	885
		110	1770
		111	3539

RESET (60H) - RESET REGISTER

D7	D6	D5	D4	D3	D2	D1	D0
Writing any data to Reset Register in address 60H can reset LP3954							
r-0	r-0	r-0	r-0	r-0	r-0	r-0	r-0

Physical Dimensions inches (millimeters) unless otherwise noted

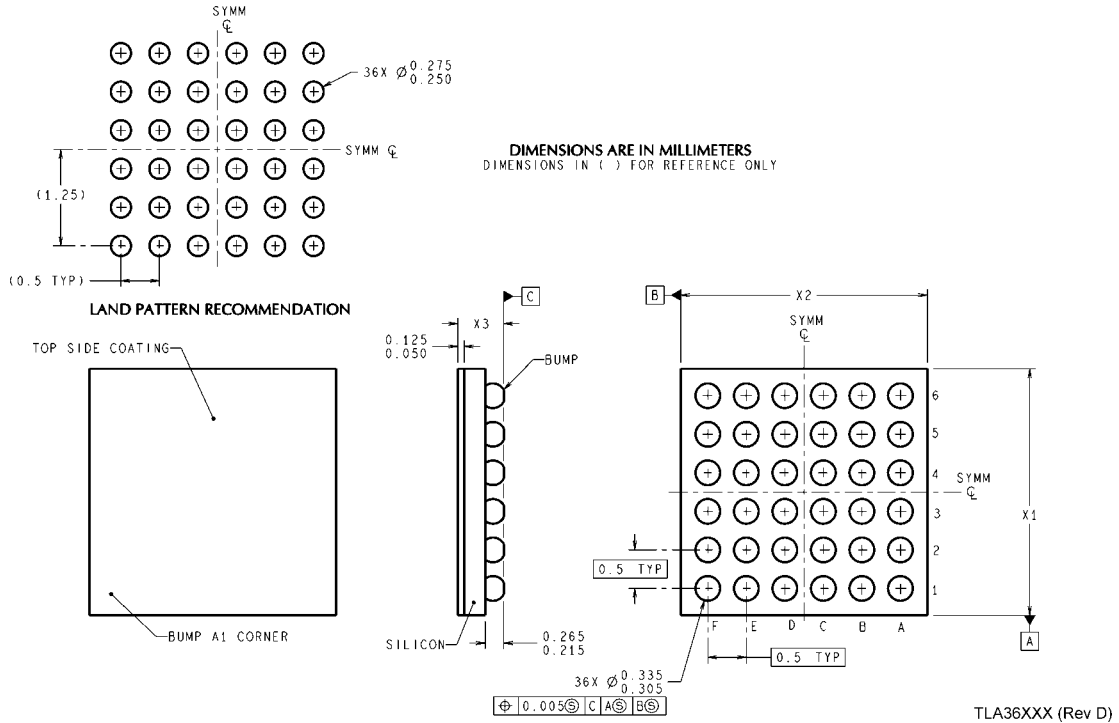

The dimension for X1 ,X2 and X3 are as given:

- X1=3.00mm ±0.03mm
- X2=3.00mm ±0.03mm
- X3=0.60mm ±0.075mm

36-bump micro SMD Package, 3 x 3 x 0.6mm, 0.5mm pitch
NS Package Number TLA36AAA

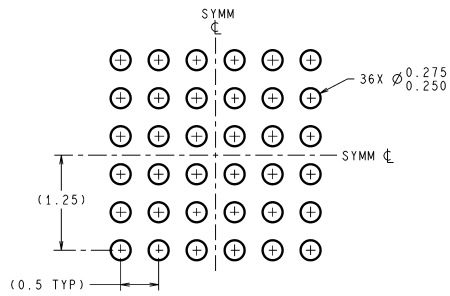

LAND PATTERN RECOMMENDATION

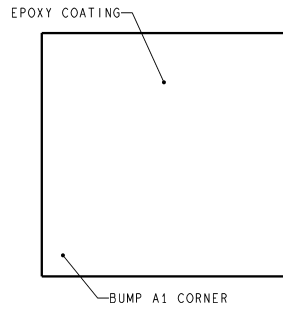

DIMENSIONS ARE IN MILLIMETERS
DIMENSIONS IN () FOR REFERENCE ONLY

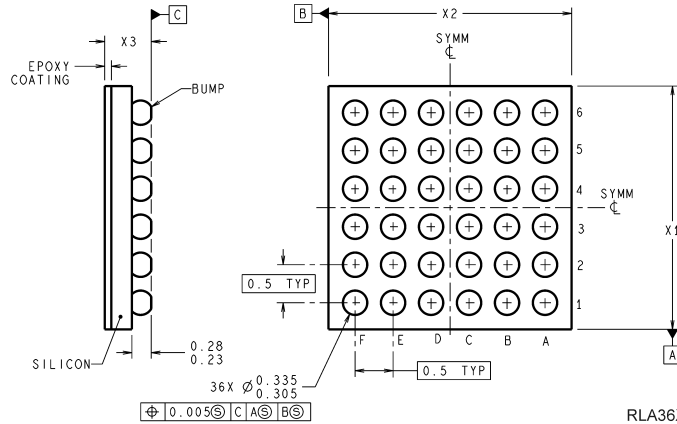

RLA36XXX (Rev A)

The dimension for X1 ,X2 and X3 are as given:

- X1=3.00mm ±0.03mm
- X2=3.00mm ±0.03mm
- X3=0.65mm ±0.075mm

36-bump micro SMDxt Package, 3 x 3 x 0.65mm, 0.5mm pitch
NS Package Number RLA36AAA

See Application note AN1112 for micro SMD and AN1412 for micro SMDxt PCB design and assembly instructions.

Notes

Notes

THE CONTENTS OF THIS DOCUMENT ARE PROVIDED IN CONNECTION WITH NATIONAL SEMICONDUCTOR CORPORATION ("NATIONAL") PRODUCTS. NATIONAL MAKES NO REPRESENTATIONS OR WARRANTIES WITH RESPECT TO THE ACCURACY OR COMPLETENESS OF THE CONTENTS OF THIS PUBLICATION AND RESERVES THE RIGHT TO MAKE CHANGES TO SPECIFICATIONS AND PRODUCT DESCRIPTIONS AT ANY TIME WITHOUT NOTICE. NO LICENSE, WHETHER EXPRESS, IMPLIED, ARISING BY ESTOPPEL OR OTHERWISE, TO ANY INTELLECTUAL PROPERTY RIGHTS IS GRANTED BY THIS DOCUMENT.

TESTING AND OTHER QUALITY CONTROLS ARE USED TO THE EXTENT NATIONAL DEEMS NECESSARY TO SUPPORT NATIONAL'S PRODUCT WARRANTY. EXCEPT WHERE MANDATED BY GOVERNMENT REQUIREMENTS, TESTING OF ALL PARAMETERS OF EACH PRODUCT IS NOT NECESSARILY PERFORMED. NATIONAL ASSUMES NO LIABILITY FOR APPLICATIONS ASSISTANCE OR BUYER PRODUCT DESIGN. BUYERS ARE RESPONSIBLE FOR THEIR PRODUCTS AND APPLICATIONS USING NATIONAL COMPONENTS. PRIOR TO USING OR DISTRIBUTING ANY PRODUCTS THAT INCLUDE NATIONAL COMPONENTS, BUYERS SHOULD PROVIDE ADEQUATE DESIGN, TESTING AND OPERATING SAFEGUARDS.

EXCEPT AS PROVIDED IN NATIONAL'S TERMS AND CONDITIONS OF SALE FOR SUCH PRODUCTS, NATIONAL ASSUMES NO LIABILITY WHATSOEVER, AND NATIONAL DISCLAIMS ANY EXPRESS OR IMPLIED WARRANTY RELATING TO THE SALE AND/OR USE OF NATIONAL PRODUCTS INCLUDING LIABILITY OR WARRANTIES RELATING TO FITNESS FOR A PARTICULAR PURPOSE, MERCHANTABILITY, OR INFRINGEMENT OF ANY PATENT, COPYRIGHT OR OTHER INTELLECTUAL PROPERTY RIGHT.

LIFE SUPPORT POLICY

NATIONAL'S PRODUCTS ARE NOT AUTHORIZED FOR USE AS CRITICAL COMPONENTS IN LIFE SUPPORT DEVICES OR SYSTEMS WITHOUT THE EXPRESS PRIOR WRITTEN APPROVAL OF THE CHIEF EXECUTIVE OFFICER AND GENERAL COUNSEL OF NATIONAL SEMICONDUCTOR CORPORATION. As used herein:

Life support devices or systems are devices which (a) are intended for surgical implant into the body, or (b) support or sustain life and whose failure to perform when properly used in accordance with instructions for use provided in the labeling can be reasonably expected to result in a significant injury to the user. A critical component is any component in a life support device or system whose failure to perform can be reasonably expected to cause the failure of the life support device or system or to affect its safety or effectiveness.

National Semiconductor and the National Semiconductor logo are registered trademarks of National Semiconductor Corporation. All other brand or product names may be trademarks or registered trademarks of their respective holders.

Copyright© 2007 National Semiconductor Corporation

For the most current product information visit us at www.national.com



**National Semiconductor
Americas Customer
Support Center**
Email:
new.feedback@nsc.com
Tel: 1-800-272-9959

**National Semiconductor Europe
Customer Support Center**
Fax: +49 (0) 180-530-85-86
Email: europe.support@nsc.com
Deutsch Tel: +49 (0) 69 9508 6208
English Tel: +49 (0) 870 24 0 2171
Français Tel: +33 (0) 1 41 91 8790

**National Semiconductor Asia
Pacific Customer Support Center**
Email: ap.support@nsc.com

**National Semiconductor Japan
Customer Support Center**
Fax: 81-3-5639-7507
Email: jpn.feedback@nsc.com
Tel: 81-3-5639-7560