

Proximity Sensor SFH 7741

Application note

1. Introduction

The SFH 7741 is a very small reflective optical sensor for short distances with digital output. With dimensions of only $3.7 \times 3.7 \times 1 \text{ mm}^3$, and surface-mount solder contacts, the device may be integrated in applications where reflective sensors have previously not been considered. A photograph of the part is shown in figure 1.

This device was conceived to operate as a short- to medium-distance proximity sensor. The typical operating range is around 30 mm for a diffusely reflecting target with high reflection coefficient (for example, white non-glossy paper). Based on the low mean current consumption ($45 \mu\text{A}$) the target applications include especially mobile devices with touch-screens (e.g. cell phones, PDAs, portable entertainment devices) that must be turned off if placed near the user's face. It could also be used in other proximity applications such as contactless switches (as in Figure 2 for example).

This application note is structured as follows:

- General description of the part's design and operating principle
- Application circuit recommendations
- Customization to account for optical properties of the application
- General application comments



Figure 1: Photo of the SFH 7741. Contact pads are on the bottom side of the package

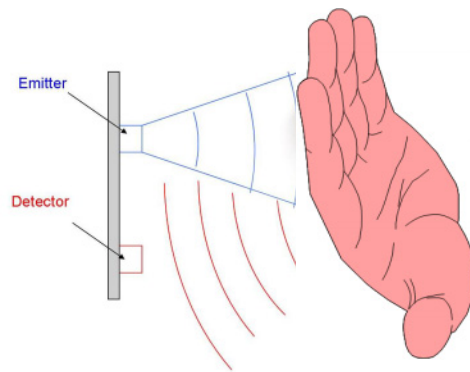

Figure 2: The SFH 7741 may be used to implement a contactless or proximity switch. The presence of a hand or finger (the target) is detected by the reflection of light from the target.

2. Design and Operating Principle

The part consists of an infrared light emitting diode (LED) with a wavelength of 850nm, a phototransistor, and an ASIC. A block schematic diagram is shown in Figure 3. For low current consumption (45 μ A average at $V_{dd}=3V$, $R_{prog}=470\Omega$) the ASIC performs a measurement every 90ms and the result is latched at the output and held until the next measurement result is present. When a measurement is performed, the emitter is driven with current I_f for 44 μ s. The phototransistor current I_p is measured twice: immediately prior to the emitter pulse, and just before the end of the emitter pulse respectively. The difference between the two measurements is compared with an internal threshold setting, and the output is set to the appropriate digital level (indicating presence, high "H", or absence, low "L", of reflected light).

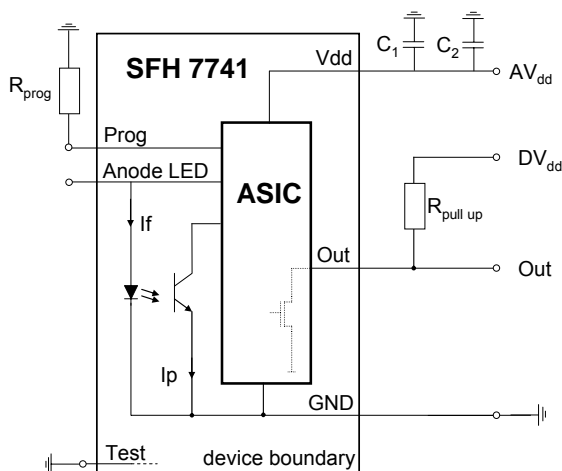

Figure 3: SFH 7741 block diagram, also showing recommended external discrete components.

Since the difference in photocurrent is measured, the device is insensitive to ambient light conditions to a wide extent. If the device is used indoors (e.g. fluorescent lamps, light bulbs up to 1000 lx), the device functions as described above. For light sources with very high infrared content (e.g.

light bulb >1000lx, direct sunlight > 10000lx), the amplifier in the ASIC may be pushed beyond its design dynamic range, in which case the output will switch to H. A solution will be discussed in section 3.

The ASIC decision circuit includes a hysteresis to avoid a situation where the output would toggle between subsequent measurements for a given sensor-target distance (i.e. the proximity signal is effectively debounced). This is shown schematically in Figure 4.

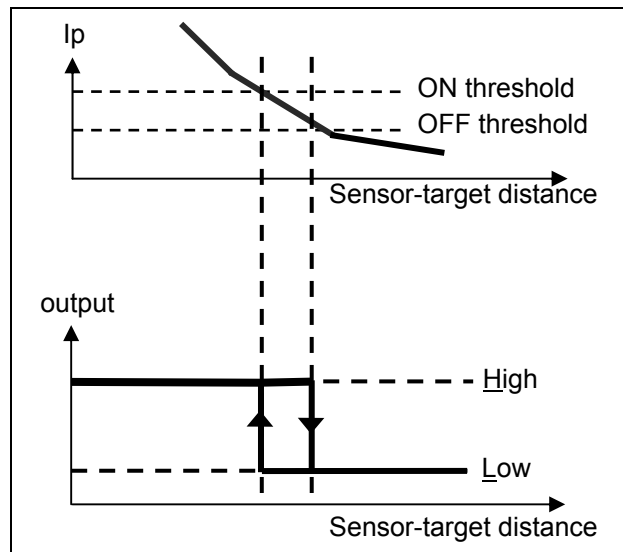

Figure 4: SFH 7741 output as a function of the photocurrent I_p , illustrating the decision circuit hysteresis.

The device has an internal preset emitter drive current I_f of 10 mA. Depending on the desired operating range and target reflectivity, this current may be insufficient to achieve the desired performance. In this case, the emitter drive current I_f can be increased up to 60mA by using an additional external resistor (see section 4).

3. Application Circuit

The electrical set-up and the proposed external components are shown in Figure 3.

An external **pull-up resistor** is required at the output. A value of 100kΩ is recommended, but up to 1MΩ can be used to keep the current consumption low. In this case the circuit will be more sensitive to noise.

The power supply **bypass capacitor C₁** is necessary to reduce high frequency noise – 10-100nF is recommended.

A further (larger) **bypass capacitor C₂** may be necessary to stabilize V_{dd} during the “on-time” (44μs) of the IR-emitter. The voltage drop of the supply voltage during this time must be < 200mV, otherwise the sensor will not function reliably. This is particularly important when the conductive path to the V_{dd} pins has a high resistance or is switched by a series transistor. In combination with higher emitter drive currents the resistance will lead to a drop of the supply voltage V_{dd} at the device. For a V_{dd} series resistance R_s between 1Ω - 10Ω a C_2 capacitor of 47μF is recommended. This will lead to a sensitivity decrease (compared to a perfectly flat supply voltage) of less than 10% (emitter drive current $I_f = 50\text{mA}$). For R_s between 0.5Ω - 1Ω a C_2 capacitor of 10μF is necessary. Smaller R_s can be compensated with a 1μF capacitor.

The emitter drive current may be increased by adding a resistor R_{prog} , which should be placed close to the device. The choice of the resistor value is discussed in section 4.

The **Test** pin should be connected directly to GND in the application. Connecting this pin to V_{dd} activates the ASIC test mode, used in the final factory functionality test. The part in principle functions properly also in this mode, but with significantly higher power consumption than in normal operating mode.

The part is not qualified or warranted to run in test mode for any significant period of time.

The **anode** of the emitter is provided for testing purposes at OSRAM. This contact must not be connected in the application.

As discussed in section 2, the ambient light suppression of the SFH 7741 may not function correctly in very bright conditions. For applications with a high level of ambient light, the SFH 7741 can be used in combination with an ambient light sensor. A sensor such as SFH 5711 or SFH 3710 is recommended. For ambient light levels higher than the limit of 1000 lx, the output of the proximity sensor should be ignored. This procedure does not influence the proximity sensing functionality for most of the applications, if the sensor is exposed to bright light. As soon as an object (e.g. hand, head) appears in the sensing range of the sensor, it will partly cover the ambient light sensor and the SFH 7741, resulting in an acceptable level of effective ambient light, which allows proper functionality of the proximity sensor. It is important that the ambient light sensor and the SFH 7741 are positioned close to each other, so that the shade covers both, the proximity sensor as well as the ambient light sensor.

4. Optical design

4.1 Calculation of R_{prog}

The ASIC determines target proximity by looking at the amount of phototransistor current I_p . The amount of light reflected back to the detector, and hence magnitude of I_p , depends on the following factors:

- Emitter drive current I_f
(higher I_f -> more light -> higher I_p)
- Reflectivity and size of the object
(higher reflectivity -> higher I_p)
- Distance between sensor and object
(larger distance -> lower I_p)

A full discussion of these relationships is presented in the Application Note “[Proximity Sensors - Part 1: Optics and Mechanics](#)” (please contact your sales representative for a copy). As a point of reference, **OSRAM OS** is using a standard target with 90% reflectivity (KODAK neutral white paper—may be ordered from KODAK, Cat. No. E 152 7799, Publication R-270).

The typical switching distance as a function of the emitter current I_f is shown in Figure 5 for 90% reference KODAK white paper and for a 50% (typical human skin) reflector. Such reflectors, like a hand or cheek, have an area larger than 50 x 50 mm². This does not significantly change the result in Figure 5, as the majority of reflected light intensity comes from an area of 50x50 mm². For smaller reflectors, the typical switching distance can differ from the values shown in Figure 5 (i.e. it may be shorter, as the

effective target reflectivity scales with the target area). The typical switching distance of a human finger for example is 17 mm compared to 30mm with KODAK white paper (50x50mm², $I_f = 50\text{mA}$).

Based on the necessary I_f (taken from Figure 5 for a desired operating range), the R_{prog} can be calculated using the following formula:

$$R_{prog} = \frac{V_{dd} * 6}{I_f - 10\text{mA}}$$

Where

- 10 mA is the ASIC preset I_f current
- the factor of 6 is based on ASIC properties

The maximum allowed forward current I_f is 60mA.

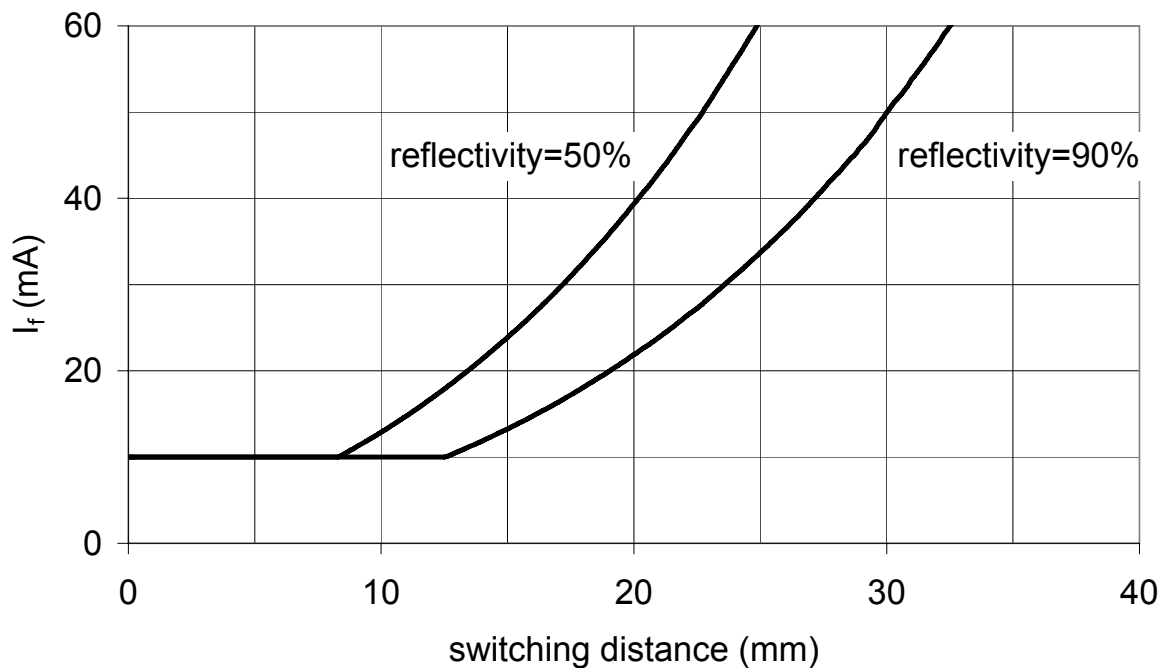

Figure 5: SFH 7741, required emitter current I_f for achieving typical switching distance. (Diffuse reflector 50x50mm²)

Depending on the V_{dd} and R_{prog} the typical current draw I_{dd} can be seen in Figure 6.

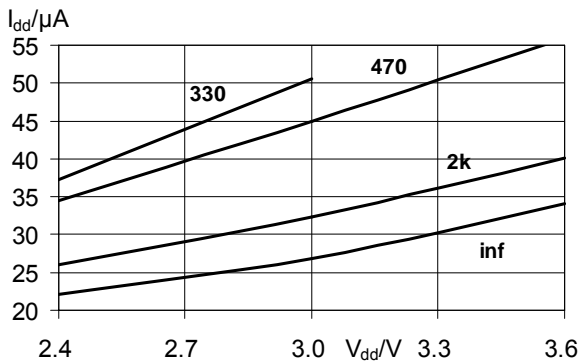

Figure 6: SFH 7741; current consumption as a function of V_{dd} for different R_{prog} parameter.

4.2 Interference

In any reflective optical sensor, the detector receives light not only from the desired target. Ambient light, as well as reflections from other objects such as frames or covers, contribute to the detector signal.

Figure 7 shows the set up of a proximity sensor inside a device. In most applications the sensor may be placed behind an IR-transparent window. The detector signal comprises signal portions from

- light reflected by the detected object,
- ambient light,
- crosstalk due to cover window, frames or other objects in the vicinity

Ambient light suppression has already been discussed. For proper application of the sensor, the effect of crosstalk signal must be considered.

The SFH 7741 cannot separate between IRED-light reflected from the object to be detected and IRED-light which is reflected from the cover (see Figure 7). Therefore it is necessary to place a separator between emitter and detector to minimize this effect. The separator blocks the relevant beams, allowing the sensor to detect only target reflections, but has the side effect of reducing the sensor sensitivity. For a full

discussion of these issues, it is strongly recommended to consult the Application Note “Proximity sensors / Part 3: Crosstalk due to sensor packaging” (please contact your sales representative for a copy).

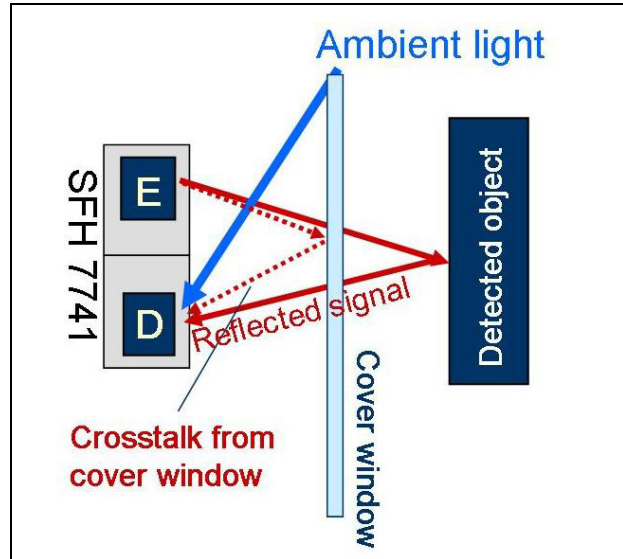

Figure 7: SFH 7741 proximity sensing set-up

For a given drive current, the operating range will always be smaller with a cover and separator than without one. This must be taken into account when choosing the appropriate I_f .

5. General Comments

5.1 Internal timing

In order to keep the current consumption as low as possible, a special timing sequence of the sensor is implemented in the IC (Figure 8, Table 1). Every $\sim 90ms$ the device starts a new measurement cycle. During this cycle, the on-time for the IRED is kept as short as possible. Figure 8 shows the time sequence of the device.

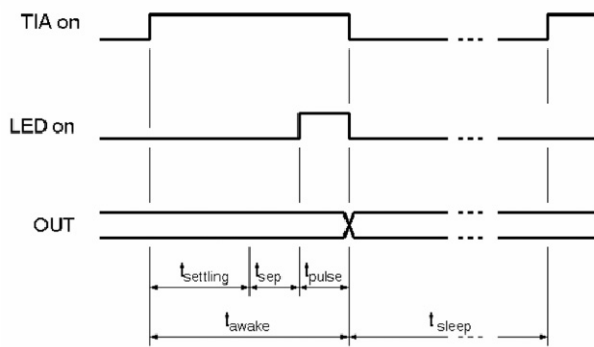

Figure 8: SFH 7741 time sequence

The measurement cycle t_{awake} starts after 90ms sleep time, beginning with the reference measurement for the ambient light level (1), which is saved inside the IC. Afterwards the LED is switched “On” and the reflected signal including the ambient light is measured (2). The IC calculates the level of the reflected light based on measurement (1) and (2) and switches the output.

t_{pulse} (typ.)	44 μ s
t_{awake} (typ.)	176 μ s
t_{sleep} (typ.)	90 ms

Table 1: SFH 7741 time management

5.2 Use of regulated power supplies

The IRED is driven with a current between 10mA to 60mA in pulsed mode. Therefore any series resistor connected to the V_{dd} pin causes a voltage drop on the power line during the IRED pulse. The power drop at V_{dd} must not be greater than 200mV during operation. A capacitor in the range of few μ F may help to overcome this issue, as mentioned in section 3.

When operating the SFH 7741 in a laboratory environment, regulated voltage

supplies should be avoided. Since the IR emitter pulse is much higher than the ASIC current draw (i.e. a high, low-duty cycle supply pulse), it can influence the stability of the supply voltage. This instability will influence the functioning of the SFH 7741. This effect is not observed to occur during normal operation of the sensor with batteries, storage batteries, or stabilized voltage supplies

5.3 Device handling

In order to protect the semiconductor chips from environmental influences such as moisture, an encapsulant based on silicone resin is used. Since this encapsulant is very elastic and soft, mechanical stress or damage to the silicone should be avoided during processing/assembly (see also the application note "[Handling of Silicone Resin LEDs / Part: Handling instructions](#)").

Excessive force applied to the cover can lead to a spontaneous failure of the IRED (damage to the contacts). To prevent damaging or puncturing the encapsulant, the use of all types of sharp objects should be avoided both in the laboratory and factory environments.

The package outline and the pin configuration are shown in figure 9 and table 2. For detailed technical data, please refer to the [datasheet](#).

5.4 Eye safety

The SFH 7741 sensor is eye safe by design under normal operating conditions defined in the product datasheet and according to IEC 62471 (exempt group).

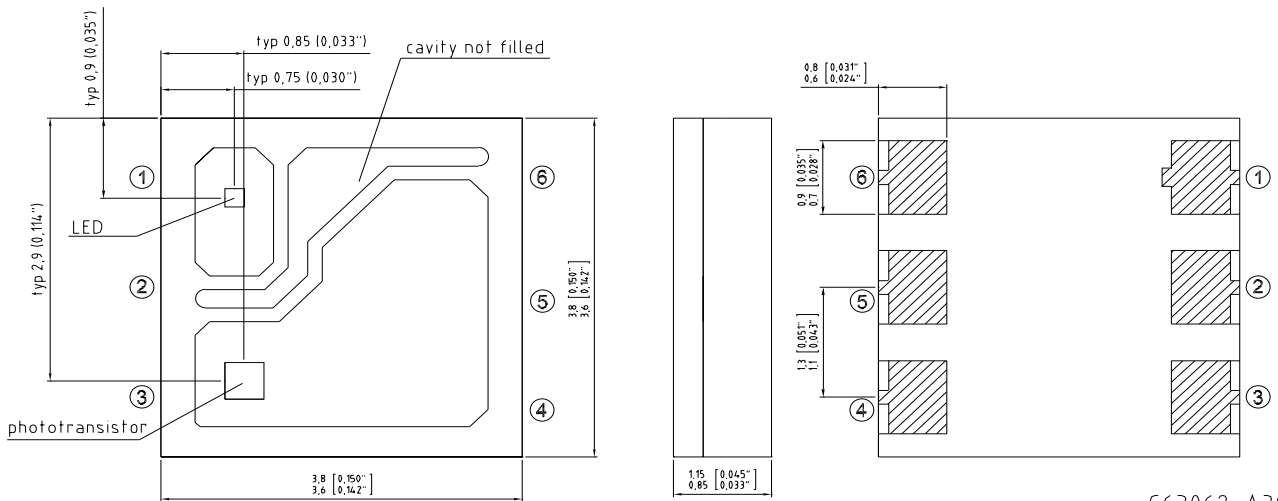

C63062-A3981-A2 -51

Figure 9: Package drawing and pin configuration of the SFH 7741

Pin	Description
1	Anode LED (must not be connected)
2	GND
3	Out
4	Test (must be connected to GND)
5	Vcc
6	Prog

Table 2: Pin configuration of the SFH 7741

Authors: Dirk Sossenheimer, Jürgen Gärtner

About Osram Opto Semiconductors

Osram Opto Semiconductors GmbH, Regensburg, is a wholly owned subsidiary of Osram GmbH, one of the world's three largest lamp manufacturers, and offers its customers a range of solutions based on semiconductor technology for lighting, sensor and visualisation applications. The company operates facilities in Regensburg (Germany), Santa Clara (USA) and Penang (Malaysia). Further information is available at www.osram-os.com.

All information contained in this document has been checked with the greatest care. OSRAM Opto Semiconductors GmbH can however, not be made liable for any damage that occurs in connection with the use of these contents.