

# General Application Note for SFH511X IR Remote Control Receivers

Figure 1. IR Remote Control Receiver



## A. Introduction

The IR remote control receiver components SFH5110 and SFH5111 are fully integrated parts for IR remote controls as well as for long distance interrupters. Fully integrated means: photodiode and electronics are integrated into one chip. No external components are required. This integration leads to a miniaturized package with high precision optics.

The SFH511X requires a power supply of  $5\text{ V} \pm 10\%$ . RC filtering is recommended to suppress power supply disturbances. The output of the device (power transistor with an internal pull up resistor) can be connected directly to the electronics in the application. The high ("H") and low ("L") level signals of the output are TTL and CMOS compatible. The electrical output signal is active low.

## B. Applications:

### Consumer Electronic Remote Control Systems

Nearly all consumer electronic products (audio, video or set top boxes) are using IR remote controls for controlling basic functions of the equipment like power on/off. An IR emitter (peak wavelength  $\approx 950\text{ nm}$ ) which is integrated in the control unit transmits a carrier based optical burst signal (carrier frequency  $f_o = 30, 33, 36, 38, \text{ or } 40\text{ kHz}$ ). Each data bit is modulated with the carrier resulting in many single pulses per data bit. The period of each pulse is  $T_o = 1/f_o$  (see fig. 2). The remote control receiver detects the signal and gives the information to the electronics of the equipment.

A typical data format contains start, system address and data or command bits. The optimum gain of the opto IC will be set using the start bits. The receiver is now ready to detect the address and data bits of the optically transmitted command. The SFH511X then converts this optical signal to an electrical output. This electrical output goes to the microcontroller, which in turn decodes it and executes the command (e.g., turn up the volume on a TV).

The address byte contains information about the equipment to be controlled. Example: A specific address byte will make sure that a TV is turned on and not the CD player which may be beside it. The data bit contains information about the required command e.g. power on/off, volume and channel select.

Details of data transmission, such as, RC5 is addressed in Appendix A.

## Low Frequency Free Air Data Transmission

The SFH511X product family is ideal for use in low frequency long distance free air data transmission. Data rates of up to 4 kbit/s (10 pulses with  $25\text{ }\mu\text{s/pulse} = 250\text{ }\mu\text{s}$  (4 kHz)) can be transmitted.

Additionally, the SFH511X product family can be used as a receiver in light curtains or long distance interrupters. For those applications "high sensitivity" (long transmission distance) and enhanced immunity from ambient light sources (e.g. natural sunlight and fluorescent lamps).

## C. Description (see fig. 3)

### The SFH511X product family contains:

- Photodiode with preamplifier
- Automatic gain control (AGC)
- Band pass filter (center frequency,  $f_o = 30, 33, 36, 38, 40\text{ kHz}$ )
- Demodulator
- Output driver (internal pull-up resistor  $23\text{ k}\Omega$ )

### Photodiode with preamplifier

The infrared light detected by the photodiode is converted into an electrical current which is amplified by the preamplifier. To minimize the influence of electromagnetic fields which are common e.g. inside TV sets the photodiode and also the integrated circuit are electrically shielded.

### Automatic gain control (AGC)

The AGC adapts the gain of the amplifier. The highest gain resp. the longest transmission distance will be achieved in the dark. Light sources like incandescent or fluorescent lamps or like the sun will reduce the gain and thus the sensitivity of the device. This gain control is necessary to avoid saturation of the circuit with increasing ambient light level resp. to minimize the effects of light interference (noise).

### Band pass filter (center frequency, $f_o = 30, 33, 36, 38, 40\text{ kHz}$ )

The band pass filter improves the SNR (signal to noise ratio) of the part by rejecting frequencies that are not within its pre defined range. This range can be selected by the customer specifying a center frequency range (e.g. 30, 33, 36, 38, 40 kHz). The center frequency of the band pass filter will be trimmed for each chip during the production process to guarantee the accuracy of the filter. A filter bandwidth (50% sensitivity) of 4 kHz is designed for the SFH511X series. To improve the SNR further the filter has a certain time constant. This will make sure, that only light bursts with more than 4 pulses/bit are being detected.

**Figure 2. Basic concept of data transmission**

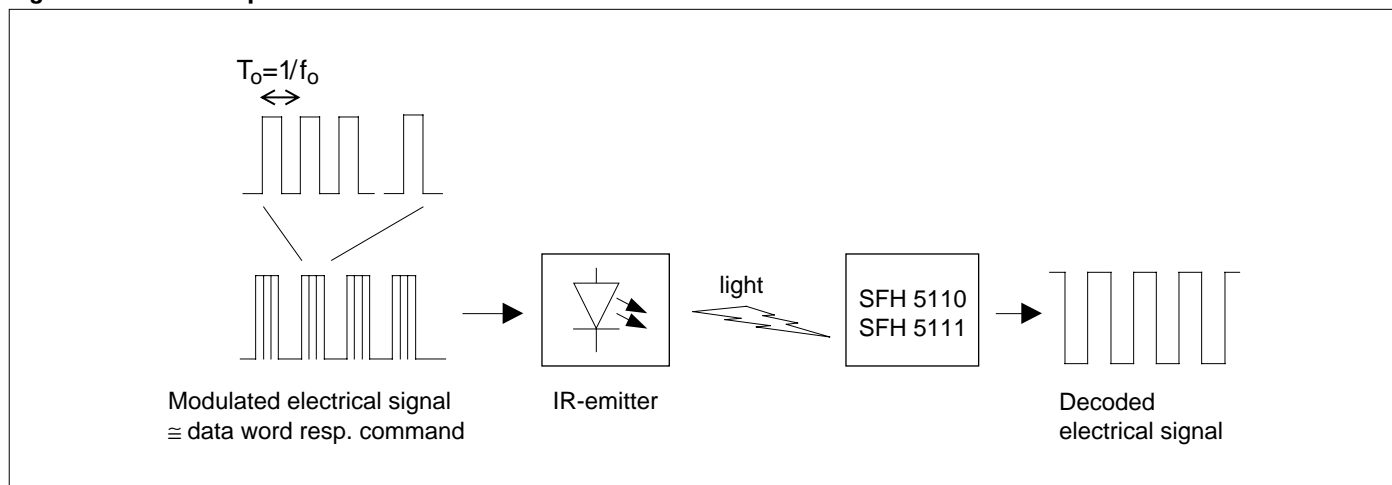

**Figure 3. Block diagram of SFH5110/5111**

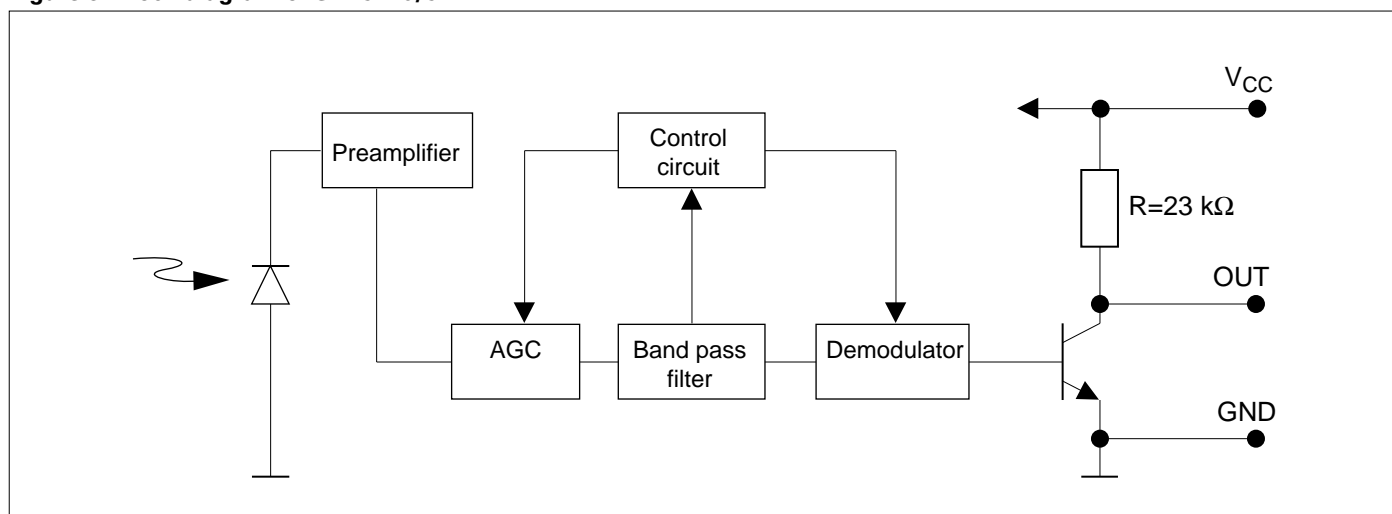

**Demodulator**

The demodulator decodes the data signal from the received signal using an integrator and a Schmitt Trigger. Pulse distortion between input and output signal is kept to a minimum by the proper design of the IC. The necessary time to change the output of the Schmitt Trigger is at least 4 cycles of the carrier frequency.

**Optical Day light suppression filter**

To suppress optical noise like ambient light the part is molded using a special black compound. The compound suppresses the visible part of the radiation. This reduces the optical sensitivity at wavelengths below 830 nm by a factor of > 10. The transmission of the filter is optimized for 950 nm IRED's (GaAs). Using 880 nm IRED's (GaAlAs) the signal will be reduced by 35%. See Table 1 for a comparison between sensitivity and transmission distance as a function of the optical wavelength.

**Output driver (internal pull-up resistor 23 kΩ)**

The output of the device (power transistor with an internal pull up resistor of 23 kΩ) can be connected directly to the electronics in the application.

**Table 1. Comparison of transmission distance at different optical wavelengths**

	Sensitivity at $E_{ambient}=0$ (dark)	typ. transmission distance at $I_e=500mW/sr$ and $E_{ambient}=0$
950 nm emitter	0.35 mW/m <sup>2</sup>	38 m
880 nm emitter	0.5 mW/m <sup>2</sup>	32 m
830 nm emitter	3.5 mW/m <sup>2</sup>	12 m

**Figure 4. Typical application circuit of SFH511X**

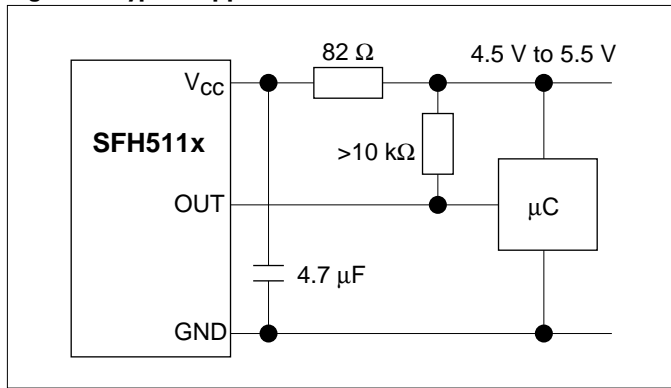

In the event it is necessary to drive the input circuit of the application with more current, an external pull-up resistor can be added in parallel to the internal. This external resistor has to be higher than 10 kΩ (see Figure 3). Using a resistor with less than 10 kΩ results in a higher load current on the output transistor. Hence the output “low level” may increase to the point where the input circuit of the application can no longer detect a active “low”. Also an external resistor with a value lower than 10 kΩ can damage the internal output driver of the SFH511X.

**Power Supply Noise:  
(Common problems)**

The SFH511X family requires a “clean” power supply, otherwise the AGC may reduce the amplification of the circuit due to noise, thus leading to less sensitivity.

Equipment interference: Televisions use an x-voltage of the tube of 15.625 kHz. The first harmonic is at 31.25 kHz, which is in the frequency range of the IR receiver circuit. If this 31.25 kHz noise is on the supply voltage, it can interfere with the IR receiver resulting in less sensitivity.

Switched mode power supplies.

The center frequency of the SFH511X should not be the same as the frequency of any switched mode power supply that is being used to power the application. *Otherwise the amplification of the circuit may be reduced due to noise, thus leading to less sensitivity.*

Common problems solutions.

Such problems can be overcome by adding an external RC-filter close to the SFH511X power supply lead.  $R_s(=R_1)=82 \Omega$  and  $C=4.7 \mu F$  (see Figure 4) have been found to be a good compromise between cost and performance. In certain applications a special designed low pass filter might be necessary.

See Appendix B.

Please note:

The voltage at the  $V_{CC}$  pin should not go below 4.5 V, the SFH511X may not function properly. E.g. using a series resistor of  $R_s=330 \Omega$  results in a supply voltage at the  $V_{CC}$  pin of only 4.4 V, although 5 V has been applied externally ( $V_{SFH511X}=V_{CC}-I_{CC} \cdot R_s=5 V-1.7 mA \cdot 330 \Omega=4.4 V$ ).

**D. Sensitivity/transmission distance**

The operation of an IR remote control is influenced by the following:

- sensitivity of the IR receiver
- optical power and wavelength of the IR emitter
- distance between emitter and receiver
- ambient conditions (optical noise, ambient light, temperature, obstacles in the optical path).

To calculate the transmission distance apply the Inverse Square Law. Irradiance  $E_e$ , radiant intensity  $I_e$  and the distance  $d$  are according to the formula below:

$$E_e = \frac{I_e}{d^2}$$

This means  $E_e$  is becoming less by the inverse of the squared distance.

Using the minimum specified irradiance of the IR remote control receiver (see data sheet  $E_{e\min}$ ) and the radiant intensity of any IR emitter  $I_e$  the following chart has been calculated.

**Figure 5. Transmission distance of the SFH511X**

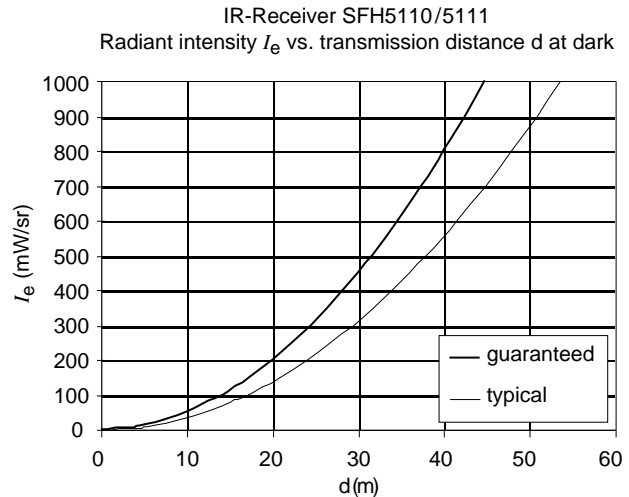

Using an OSRAM high power 950 nm emitter SFH 4515, the radiant intensity at 1A pulse current is typically 500 mW/sr. According to Figure 5, the minimum transmission distance is 30 m using the SFH511X. This distance is only valid, if there is no obstacle in the optical path between emitter and receiver and the emitter is geometrically adjusted to the detector.

**Burst/transmission codes**

The typical sensitivity of the SFH511X family is specified for burst lengths of 600 µs. Using a carrier frequency of 38 kHz, this corresponds to 23 single pulses (600 µs = 23 pulses \* 1/ 38 kHz).

Reducing the numbers of pulses/burst to <10 reduces the sensitivity of the receiver circuit, (i.e., the transmission distance is reduced).

At 6 pulses/burst the sensitivity is at 50% of it’s original value which corresponds to a 30% reduction of transmission distance.

Burst length of 2 or 3 pulses per burst will not be detected by the SFH511X. Those pulses are assumed by the internal circuitry to be optical noise and are suppressed.

Figure 6 provides an overview of the receive sensitivity performance based on Burst length—number of pulses per burst.

**Figure 6. Receive sensitivity vs. number of pulses**

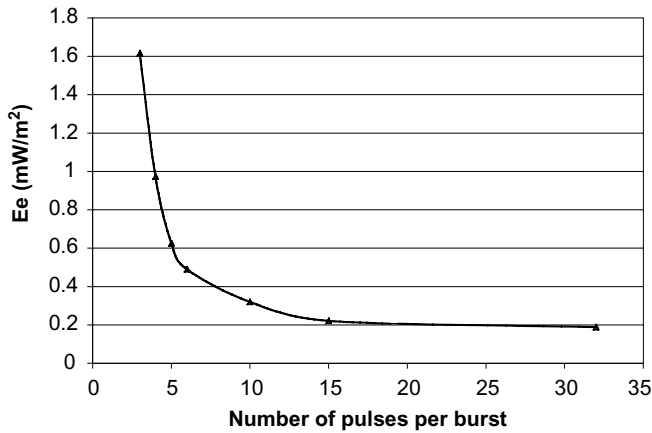

Table 2 is an overview of codes available on the market and the compatibility of the SFH511X to such codes.

**Table 2. Applicable codes for IR remote control receivers**

Transmission Code	Carrier frequency	Burst width	Use of SFH 5110/5111
RC-5	$f_o=36$ kHz	15-32 pulses	optimum use
RECS80	free/not specified	6 pulses	reduced transmission distance due to only 6 pulses/burst
NEC	$f_o=38$ kHz	22 pulses	optimum use

**Ambient light/optical noise**

Depending on ambient light conditions the transmission distance of the SFH511X may be reduced. Sunlight, incandescent lamps or filament lamps can reduce the sensitivity of the circuit. All light sources with an emission between 830 nm and 1100 nm generate optical noise for an IR remote control receiver. A 1000 lux noise (100W filament lamp at a distance of 0.5 m) reduces the transmission distance by 50%. European standards for office illumination call for a minimum illumination of 600 lux. But even under such harsh operating conditions, the SFH511X can still detect and decode data signals at a level of 1/5000 of the noise.

**Temperature dependency**

Depending on ambient temperature, the receive sensitivity or transmission distance of the SFH511X may be reduced. Figure 7 shows the effect of ambient temperature to the receiver sensitivity of the device

**Figure 7. SFH 5110 Threshold**

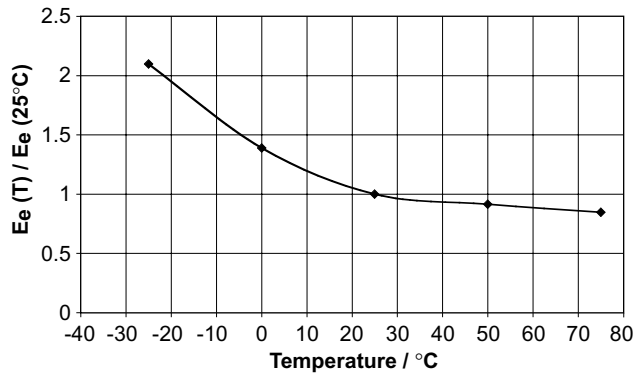

**Directional characteristics**

The elliptical lens of the SFH511X (see Figure 8) results in two different half angles. In x-direction (horizontal, landscape) the half angle is bigger, even at 55° the transmission distance is still at 70% of it's on axis figure. The y-direction (vertical, portrait) has been designed to be narrower (half angle 35°) to reduce the influence of ceiling lamps.

**Figure 8. Package/packing**

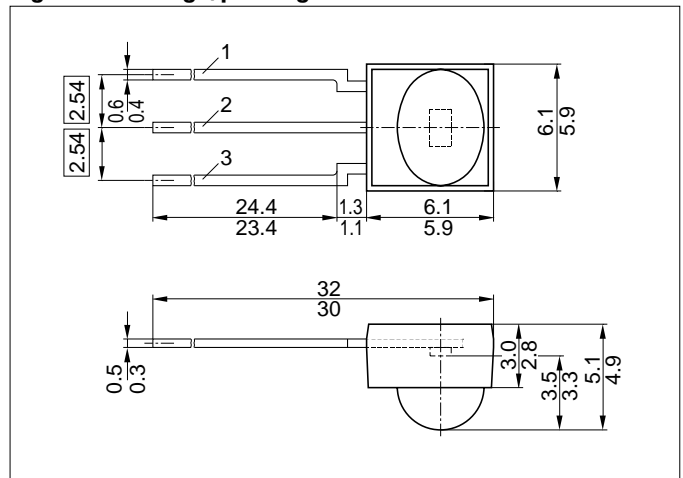

The IR remote control receiver is available with two different pin configurations. Table 3 shows the differences between SFH5110 and SFH 5111.

**Table 3. Pin connections of the SFH511X**

	1	2	3
SFH5110	OUT	GND	V <sub>CC</sub>
SFH5111	OUT	V <sub>CC</sub>	GND

The SFH511X is shipped in bulk form (packing unit 1000 pieces/box). As an option you can order ammpack (packing unit 2000 pieces/box). The ordering code for this option is E9416 e.g., SFH5110-38 E9416 for a SFH5110 with a center frequency of 38 kHz and ammpack. Other options are available on request.

Ordering information and additional technical information is available at our web site: <http://www.infineon.com/products/37/3746.htm>.

**Appendix A for Set-top Box/VCR/TV set application**

The SFH5110/SFH5111 are IR remote control receivers. They consist of a detector photodiode and an IC containing automatic gain control circuitry (AGC).

The SFH5110 has an inverted logic at its outputs. When a burst of IR is sensed from the IR remote control, the SFH5110 will drive its output to low level, meaning logic level = 1 on the transmitter.

See Figure 9 for reference of the transmit pulses from the remote control, and output pulses from SFH5110.

There are many ways to drive the SFH5110 with a different combination of bits to code the transmitted data to avoid interference.

As an illustrative material, this application note will show a general usage of SFH5110-36 with the carrier frequency of 36 KHz. In this case the burst consists of several pulses with a period of  $T_0=1/f_0=27.8 \mu\text{s}$  (nominal pulses). At 50% duty cycle its pulse width is 13.9  $\mu\text{s}$ .

On the transmit signal from the remote control, the RC-5 code, a bi-phase coding is used as an demonstration.

The transmitter protocol from the remote control utilizes a fix length bit word for "Logic 1" and "Logic 0" pulses. Each bit word is sliced in two halves, the left and right half with opposed levels (see figure 9):

Logic 1 pulse = carrier is OFF for 889  $\mu\text{sec}$  (equivalent to the time for 32 nominal pulses), followed by carrier is ON for 889  $\mu\text{sec}$  (32 nominal pulses).  
 Logic 0 pulse = ON for 889  $\mu\text{sec}$  (32 nominal pulses), followed by OFF for 889  $\mu\text{sec}$  (32 nominal pulses).

It means that if a bit "0" is transmitted, it will send 32 square pulses of 27.8  $\mu\text{second}$  duration of each pulse, then 889  $\mu\text{s}$  of no light. The bit "1" is the opposite, 889  $\mu\text{s}$  of no light followed by 32 square pulses of 27.8  $\mu\text{s}$ .

Figure 10 shows the typical data format for a complete command.

The two Start bits, # 0 and #1, are called AGC calibration. They serve to calibrate the IR Receivers Auto Gain Control during the initial burst of pulses.

The toggle bit, # 2, changes its value from "0" to "1" or vice versa at each key operation. Its main purpose is to differentiate an interruption of the transmission link from a multiple key operation.

The next 5 bits, # 3, 4, 5, 6, and 7 are used for SYSTEM ADDRESS, or to identify which kind of device should execute the COMMAND bits. For example, the manufacturer can set TV set uses ADDRESS # 0, VCR uses ADDRESS # 1, and Command bits are for adjusting the volume, channels, mute, or ON / OFF, etc.

**Figure 9. Transmit Pulses.**

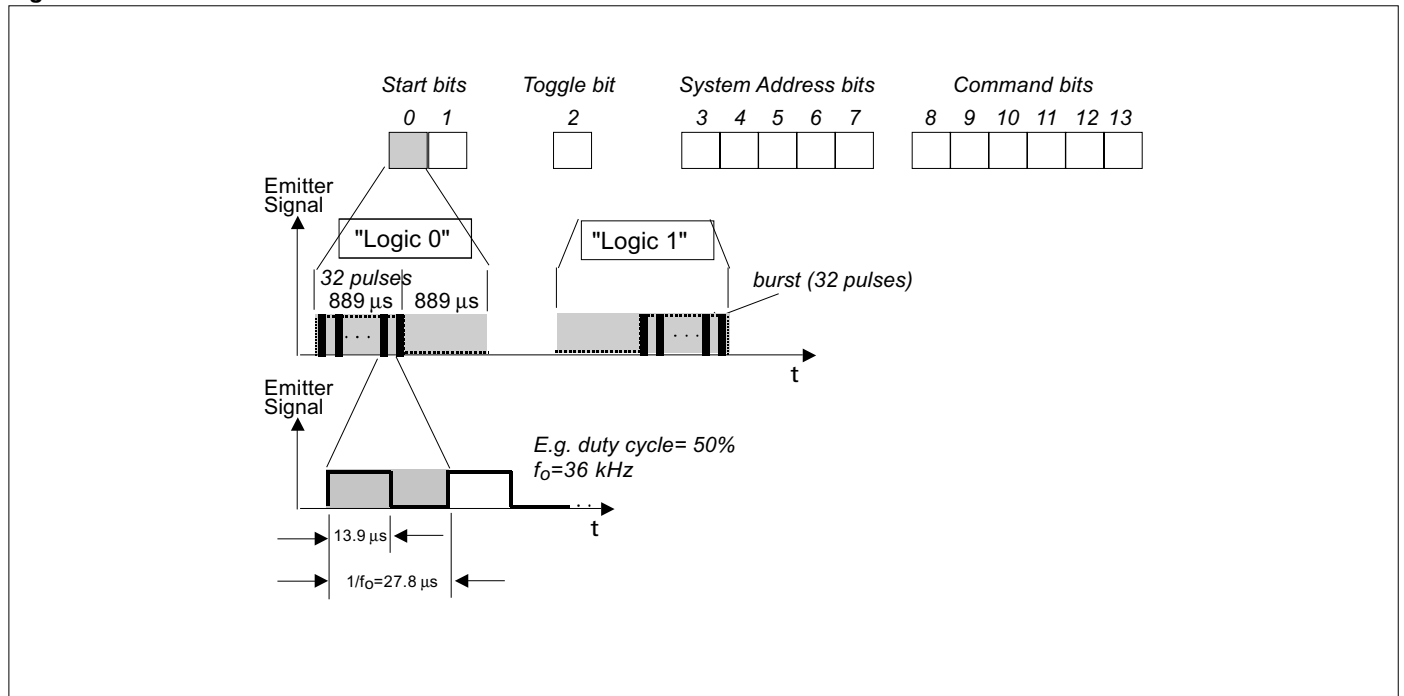

Table 4 and 5 show some examples to set the system address and command bits:

**Table 4. System Address Bits**

System Address (bit 3, 4, 5, 6, and 7)	Equipment
0	TV set
1	VCR
2	Set-top box
3	Remote control video A-B switch
Etc.	Etc.

**Table 5. Command Bits**

Command bits (8, 9,10, 11, 12, and 13)	Function description
0-9	Numeric key 0 -9
11	Standby mode
12	Mute
13	Volume up
14	Volume down
15	Brightness +
16	Brightness -
17	On
18	Off
19	Fast Rewind
20	Fast Forward
Etc.	Etc.

**Decoding with a Microcontroller**

To receive the transmit signal, a SFH5110 is used, and it inverts the bit signal, low level means bit ON.

During inactivity (no Infrared present) the output of the Infrared receiver stays high, high level means bit OFF.

The IR receiver output can be connected to any input port pin or interrupt pin of microcontroller, and keep polling it or prepare the interrupt routine to trigger the reading after the first low level sensed by either sampling the incoming pulses at fixed time intervals or measuring the pulse widths of the incoming pulses to determine if the pulse is valid before processing the incoming signals.

**Figure 10. Typical Data Formats**

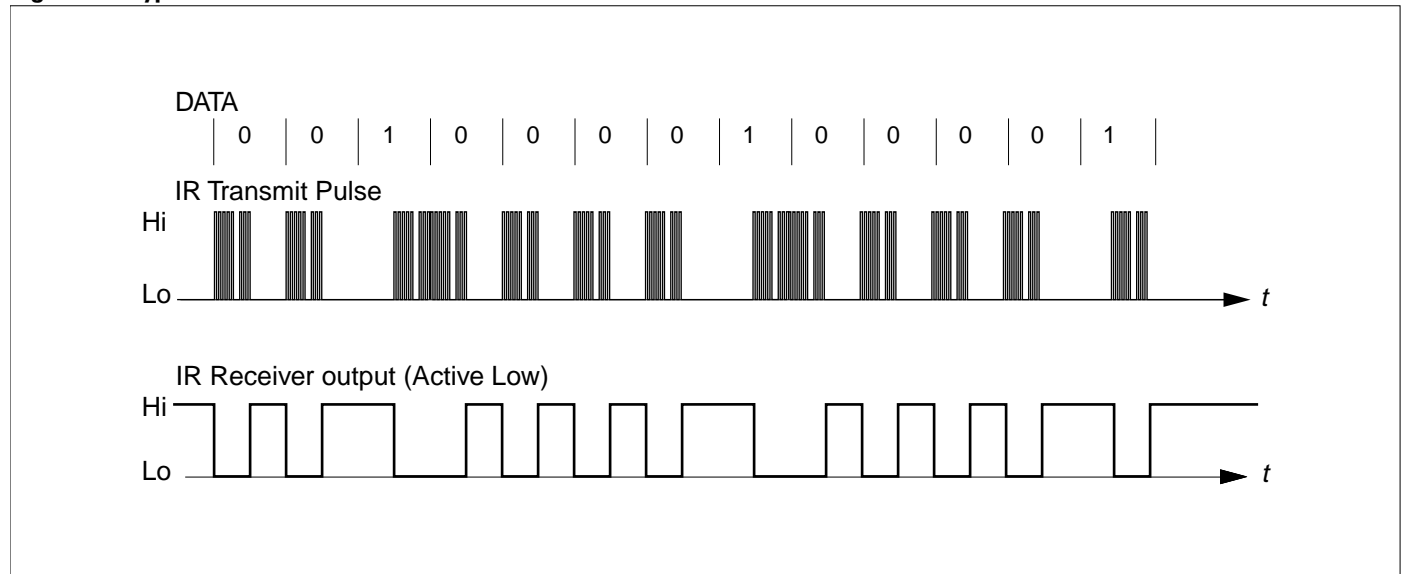

## Appendix B

### The Evaluation Board for SFH5110

The SFH5110 evaluation board is a simple two-layer printed circuit board that includes a 5.0 V regulator (LM340).

This 3-terminal positive voltage regulator provides a fixed voltage output. It eliminates noise and the power supply distribution problem from the test bench during the design and development phase.

The capacitors C1, C2, and C3 are there to filter out noise from the power supply and provide a stable voltage source to the SFH5110. Further, a low pass filter formed by R1 (68  $\Omega$ ) and C4 (10  $\mu$ f) is provided if the trace from the voltage regulator is far from the V<sub>CC</sub> of SFH5110. All these precautions are taken to attenuate noise interference and ensure frequency stability of the SFH5110 during the evaluation.

The jumper J1 is included in the board, so the user has the option to connect the output of SFH5110 to another 5.0 V power supply source independent of the 5.0 V regulator provided on the evaluation board.

Table 6 summarizes the parts list for reference.

**Table 6. Parts list**

Item 1	Qty	Part/ID number	Description	Ref. Des.
1	1	LM340	5.0 V regulator	VR1
2	1	0.33 $\mu$ f	Tantalum cap	C1
3	1	0.10 $\mu$ f	Tantalum cap	C2*
4	2	10 $\mu$ f	Tantalum cap	C3 & C4
5	1	68 $\Omega$	Resistor 1/10 W	R1
6	1	10 k $\Omega$ or higher	Resistor 1/10 W	R2
7	—	—	Shorting jumper	—
8	1	—	Straight pin, male, single row	J1
9	3	—	Socket, straight row, female	—

**Note:**

SFH5110 hole size: 0.036" +/- 0.003"

\*Preferably a ceramic cap

**Figure 11. Evaluation Board**

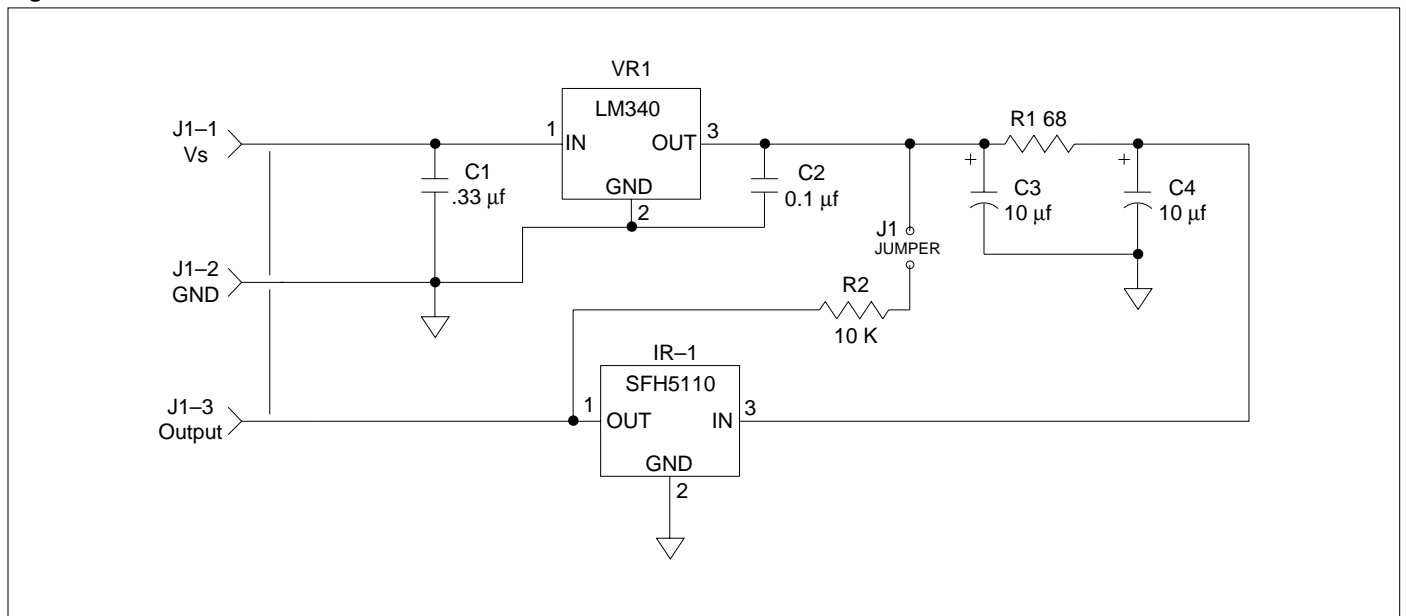

**Figure 12. SFH5110 Demo Assembly Board Lay-out**

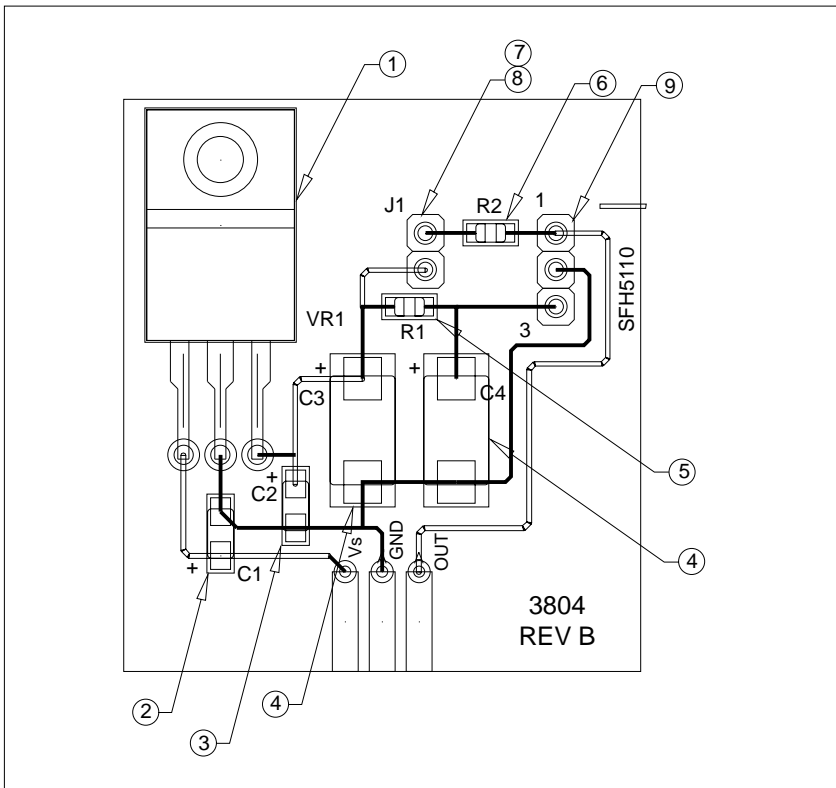

**Figure 13. SFH5110 Demo PCB Fab. Drawing**

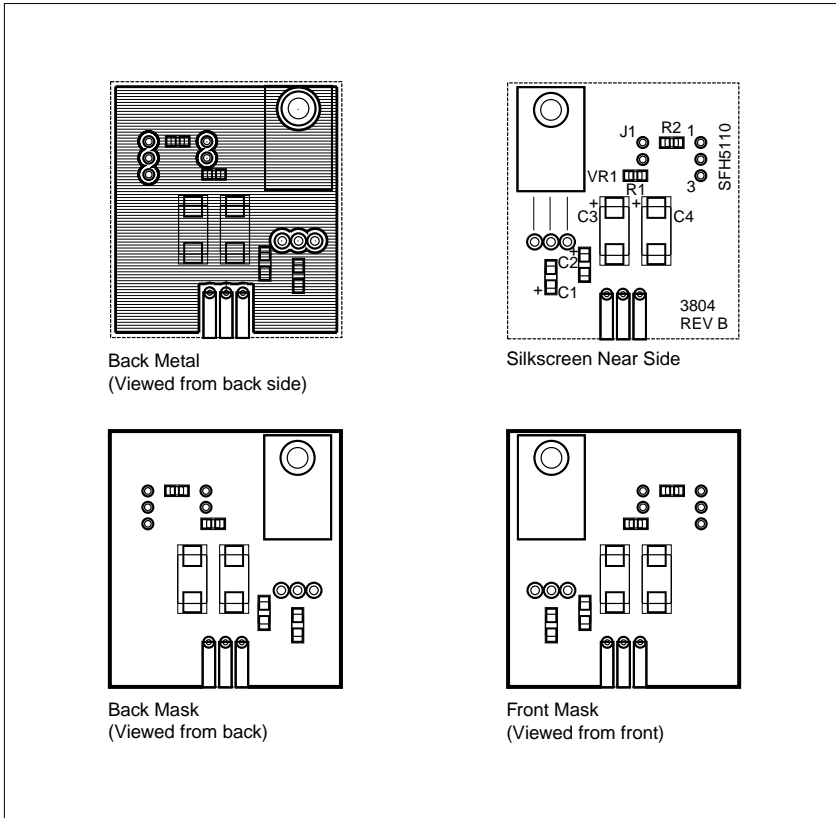

**Note:**

To reduce EMI, a large area of ground plane on the opposite side of the PCB is placed. It acts as an electrostatic shield for some of the RF energy radiated.