

# DI-136 Design Idea

## TOPSwitch-GX

### 75 W Output, High Efficiency, Single Stage Flyback Power Supply With PFC for LED Ballasts

Application	Device	Power Output	Input Voltage	Output Voltage	Topology
LED Ballast	TOP250YN	75 W	208 – 277 VAC	24 V	Flyback

#### Design Highlights

- Single stage PFC-based CV/CC power supply
- Meets harmonic content limits as specified in IEC 61000-3-2 for Class C Equipment (see Figure 2)
- Meets minimum PF requirement of 0.9 for industrial environments (>0.97 worst case at 277 VAC, see Figure 3)
- High efficiency (>85%) across entire input range
- Meets EN55015 B conducted EMI limits with >10 dB $\mu$ V margin (see Figure 4)
- Auto-restart provides indefinite output short circuit protection

#### Operation

A flyback converter with no input capacitance operating in discontinuous conduction mode inherently provides a high power factor. The schematic shown in Figure 1 takes this approach and adds an output current limit to form a high power LED driver. The circuit description below highlights the key circuit differences between this and a standard flyback converter.

To prevent large voltage transients due to AC line inductance or surges, a clamp circuit consisting of C4, D5 and R3 limits the DC bus voltage to a safe value. Once in steady state, the capacitor is effectively decoupled from the circuit by D5 so as to not impact Power Factor (PF). Resistor R3 provides a discharge path for C4.

Diode D6 prevents reverse currents through U1 that would occur when the AC input voltage is less than the reflected output

voltage. In a standard flyback converter, this condition is prevented by the DC voltage on the input bulk capacitor.

Resistors R11, R12, R13, Q2, Q3, Q4 and their associated circuitry together with the LED in U2, form the low drop CC sense circuit and program the average output current to 3.1 A ( $\pm 10\%$ ). Without a load, the output voltage is limited to about 28 V (max) by R16 and VR2.

The phototransistor (U2B) drives the emitter follower Q1 and the PFC loop compensation capacitor C10. Capacitor C10 and resistor R6 set the dominant pole for the PFC at around 0.02 Hz while R7 provides loop compensation.

Over the period of one line cycle, the current into the control pin of U1 is constant, giving a constant duty cycle and thereby providing a PFC input current waveshape.

The CONTROL pin capacitor C5 sets the startup time with D8, isolating U1 from the rest of the feedback components before regulation is reached.

An optional soft-start circuit is formed by D12, C15, R18, R19, R20, C16 and Q5. This charges C10 before the output has reached regulation and prevents output overshoot.

Diodes D10 and D11 rectify the secondary winding voltage. To distribute dissipation and improve efficiency, parallel secondary windings and diodes are used.

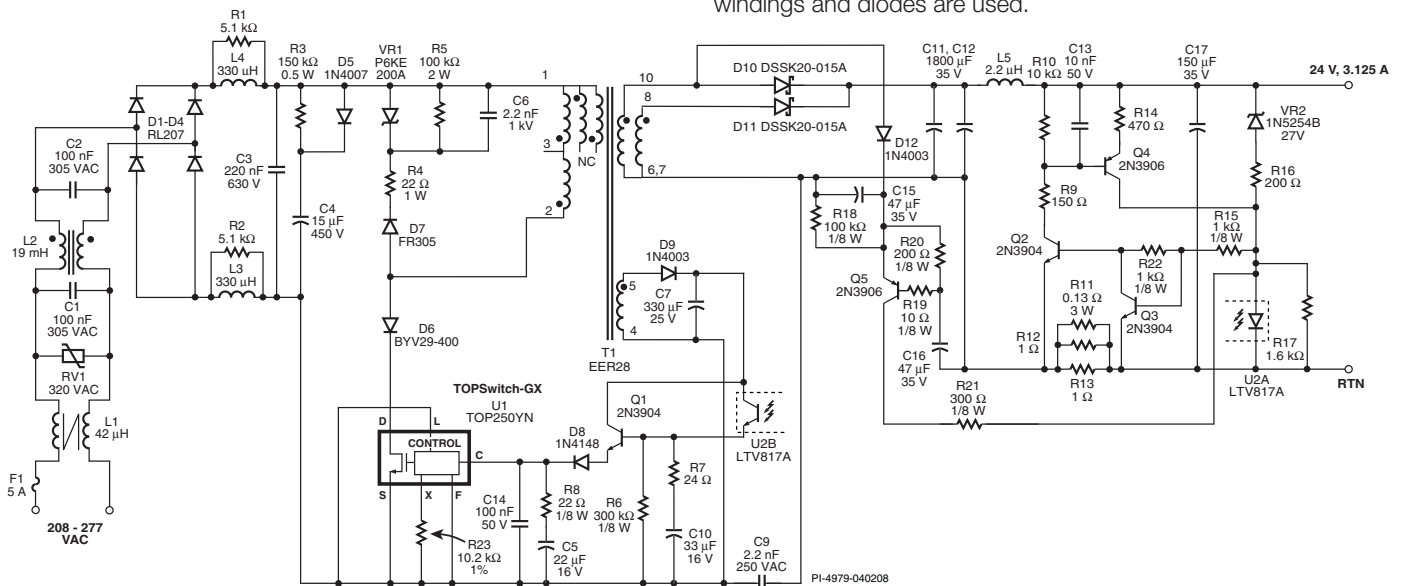

Figure 1. 75 W Single Stage LED Driver Power Supply With PFC, Using a TOP250YN Device.

## Key Design Points

- Use PI Xls spreadsheet to design the transformer. To determine the value of primary inductance, enter a peak power of 106 W, which corresponds to an average power of 75 W ( $106 / \sqrt{2}$ ). Directly enter into the spreadsheet a minimum DC voltage equal to the peak of the minimum input AC voltage.
- Set the value of KP to 1.0 to ensure critically discontinuous mode at the peak of minimum AC input voltage. Ensure that the converter operates in discontinuous mode (during steady state operation) at all times to give high power factor.
- Discontinuous mode operation increases the primary RMS currents. This impacts the size of both the transformer and the TOPSwitch-GX device.
- Select the transformer size based on thermal evaluation. This may require selecting a larger core than needed for power delivery to allow for increased wire size.

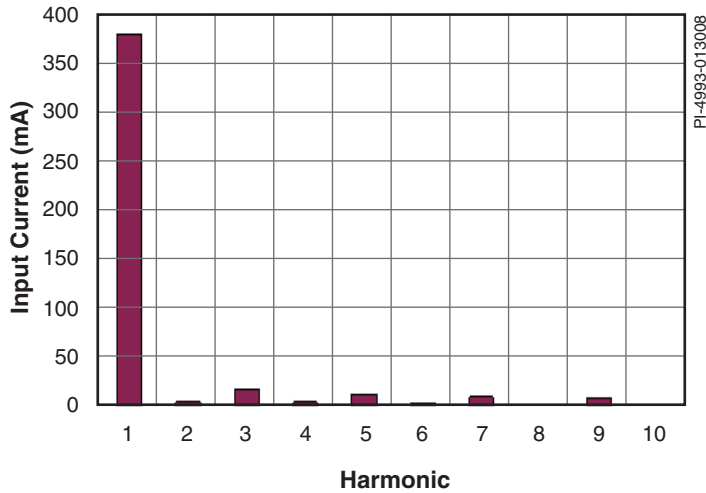

Figure 2. Harmonic Content Measured at 208 VAC.

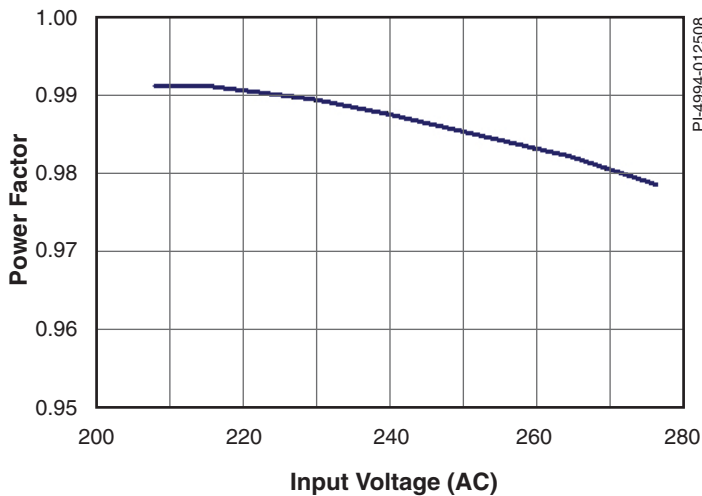

Figure 3. Power Factor (PF) Plotted Against Input Line Voltage (VAC).

- Select the TOPSwitch-GX based on acceptable efficiency and temperature rise using the X pin to program to appropriate current limit from the design spreadsheet.
- More effective thermal management through the use of thermally conductive potting compound to spread the heat from the transformer, MOSFET and diode to surrounding areas may allow a design with reduced size of heat-sink, transformer and TOPSwitch-GX.

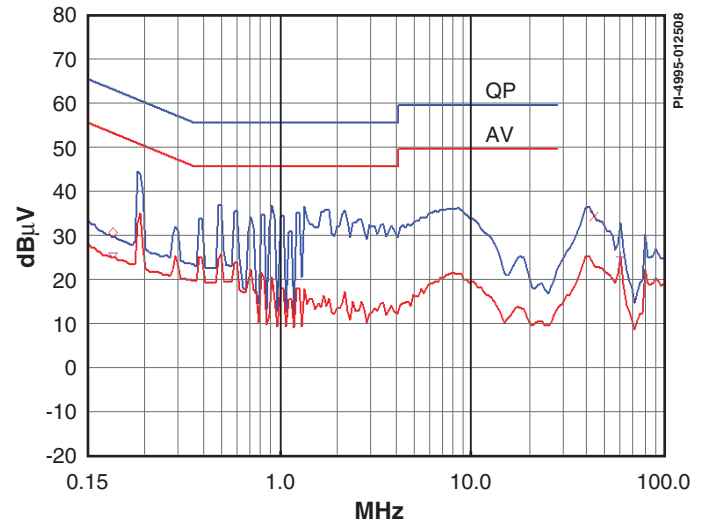

Figure 4. Worst Case Conducted EMI (230 VAC With Output Grounded) Measured Against EN55015 Limits.

## Transformer Parameters

<b>Core Material</b>	EER28 PC40 / PC44 or equivalent, gapped for ALG of 248 nH/t <sup>2</sup>
<b>Bobbin</b>	EER28, 10 pin, vertical
<b>Winding Details</b>	Shield: 9T × 3, AWG 26, tape Primary: 13T × 2, AWG 25, tape Bias: 3T × 4, AWG 28, tape Shield: 1T Foil 2 mils thick, tape (reverse wound) 24 V: 6T × 4, AWG 28 (TIW), tape Shield: 1T Foil 2 mils thick, tape Primary: 13T × 2, AWG 25, 2 layers tape
<b>Winding Order</b>	Shield (1-NC), Primary (2-3), Bias (5-4), Shield (1-NC), +12 V (8,9,10-6,7), Shield (NC-1)
<b>Primary Inductance</b>	180 µH, ±5%
<b>Primary Resonant Frequency</b>	1.2 MHz (minimum)
<b>Leakage Inductance</b>	3 µH (maximum)

Table 1. Transformer Parameters.

(AWG = American Wire Gauge, TIW = Triple Insulated Wire, NC = No Connection, )

Power Integrations  
5245 Hellyer Avenue  
San Jose, CA 95138, USA.  
Main: +1 408-414-9200  
Customer Service  
Phone: +1-408-414-9665  
Fax: +1-408-414-9765  
Email: usasales@powerint.com

On the Web  
www.powerint.com

Power Integrations reserves the right to make changes to its products at any time to improve reliability or manufacturability. Power Integrations does not assume any liability arising from the use of any device or circuit described herein. POWER INTEGRATIONS MAKES NO WARRANTY HEREIN AND SPECIFICALLY DISCLAIMS ALL WARRANTIES INCLUDING, WITHOUT LIMITATION, THE IMPLIED WARRANTIES OF MERCHANTABILITY, FITNESS FOR A PARTICULAR PURPOSE, AND NON-INFRINGEMENT OF THIRD PARTY RIGHTS. The products and applications illustrated herein (transformer construction and circuits external to the products) may be covered by one or more U.S. and foreign patents or potentially by pending U.S. and foreign patent applications assigned to Power Integrations. A complete list of Power Integrations' patents may be found at [www.powerint.com](http://www.powerint.com). Power Integrations grants its customers a license under certain patent rights as set forth at <http://www.powerint.com/ip.htm>.

The PI logo, TOPSwitch, TinySwitch, LinkSwitch, DPA-Switch, PeakSwitch, EcoSmart, Clampless, E-Shield, Filterfuse, StackFET, PI Expert and PI FACTS are trademarks of Power Integrations, Inc. Other trademarks are property of their respective companies. ©2008, Power Integrations, Inc.