

# DI-184 Design Idea

## LinkSwitch-II

### High Efficiency 7.6 V, 700 mA Isolated LED Driver

Application	Device	Power Output	Input Voltage	Output Voltage	Topology
LED Driver	LNK606PG	5.3 W	85 – 265 VAC	7.6 V	Flyback

#### Design Highlights

- Accurate primary side constant voltage, constant current (CV/CC) controller eliminates optocoupler and all secondary side CV/CC control circuitry
  - No current-sense resistors for maximized efficiency
  - Low part-count solution for lower cost
- Auto-restart protection feature reduces power delivered to the output by 95% under output short circuit or open-loop conditions
- Hysteretic thermal shutdown protects power supply from damage
- CEC and ENERGY STAR 2.0 regulations:
  - ON/OFF control provides constant efficiency to very light loads
  - No-load consumption <250 mW at 265 VAC
  - Ultra-low leakage current: <5  $\mu$ A at 265 VAC input (no Y capacitor required)
  - Meets EN55015 and CISPR-22 Class B EMI
- Green package: halogen free and RoHS compliant

The LNK606PG (U1) combines a power switching device, oscillator, CV/CC control engine, and startup and protection functions in one IC.

Diodes D1 through D4 rectify the AC input. Capacitors C1 and C2 filter the rectified AC. In combination with inductors L1 and L2, these capacitors also attenuate conducted differential-mode EMI noise. Resistors R1 and R2 dampen any resulting resonant ringing between capacitors and inductors. This configuration, along with Power Integrations' transformer E-Shield™ technology, ensures meeting EMI standard EN55015 class B with >10 dB margin, using no Y capacitor. Fusible resistor RF1 limits inrush current at startup, and fuses if any component fails from excess input current.

This power supply design uses the inherent CC feature of U1 to drive LED loads and can operate at maximum power output in CC mode. IC U1's CV mode provides output overvoltage protection if an LED should have an open-circuit failure.

#### Operation

Figure 1 shows the schematic for a universal input, 7.6 V, 700 mA CV/CC power supply for LED driver applications, using the LinkSwitch-II product LNK606PG in a flyback configuration.

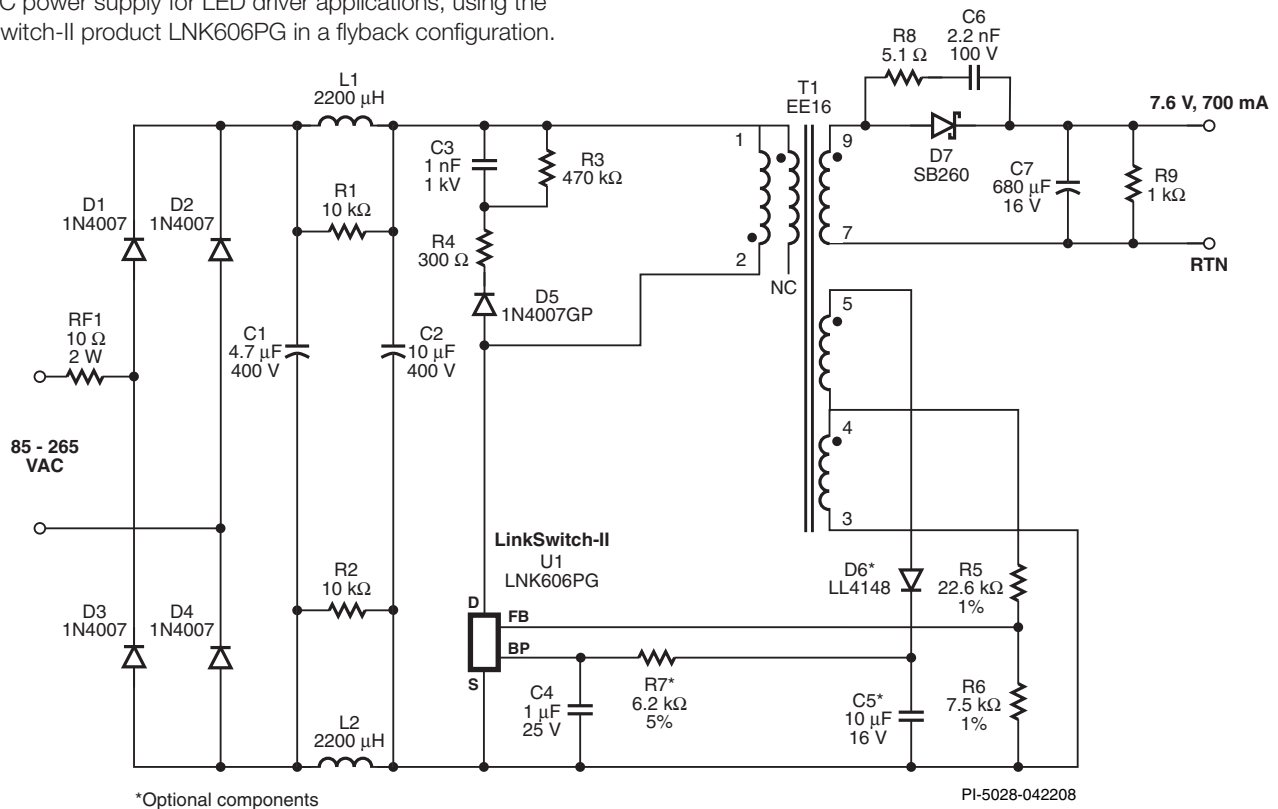

\*Optional components

PI-5028-042208

Figure 1. Schematic of a Universal Input, 7.6 V, 700 mA Isolated LED Driver.

When operating in the CC region, U1 regulates the output current by changing the MOSFET's switching frequency. As the output voltage increases, U1 increases its switching frequency. The output voltage is determined by the number of LEDs in the load. The values of resistors R5 and R6 determine the maximum switching frequency and output voltage. The transformer inductance ensures the driver always operates at maximum power.

If an output fault condition occurs, the supply operates in CV mode and uses ON/OFF control to regulate the output voltage. This provides inherent output fault protection and reduces power consumption in such situations. IC U1's auto-restart feature provides protection against output short-circuit conditions.

IC U1 is completely self-powered from the BP (BYPASS) pin and decoupling capacitor C4, which also provides high frequency decoupling. U1 uses the energy stored in C4 when the internal MOSFET is on, and the internal 6 V regulator draws current from the DRAIN pin when the MOSFET is off. This eliminates the need for an external bias winding. Adding an external bias winding further reduces the no-load power consumption.

The rectified and filtered input voltage is applied to one side of the primary winding of T1. The other side of the transformer's primary winding is driven by U1's integrated MOSFET. An RCD-R clamp consisting of D5, R3, R4, and C3 limits any drain voltage spikes caused by leakage inductance.

IC U1 automatically compensates for tolerance differences in the primary magnetizing inductance. Output power is directly proportional to the set primary inductance and changes to the output

power are sensed at the FB pin. Output changes cause adjustments to the switching frequency, compensating for inductance fluctuations.

Diode D7 (Schottky barrier, for high efficiency) rectifies the transformer's secondary output and C7 filters it. Resistor R8 and capacitor C6 remove high-frequency conducted and radiated EMI. Pre-load resistor R9 acts as a bleeder to C7 when there is no load attached.

### Key Design Points

- Extended creepage distance between high and low voltage pins on U1 prevents arcing and further improves reliability – an asset in very humid or polluted environments.
- Capacitor C7 has a low ESR to reduce output voltage ripple and eliminate the need for an LC post filter.
- Feedback resistors R5 and R6 have 1% tolerances to center both the nominal output voltage and the CC regulation threshold tightly.
- Using an optional bias winding lowers no-load power consumption even more.
- Place the BYPASS pin capacitor physically close to U1 on the PCB.
- Minimize clamp and output diode loop areas to reduce EMI.
- Space the AC input away from switching nodes to minimize noise coupling that may bypass input filtering.
- Verify the peak Drain voltage at U1's D pin is below 650 V. If not, reduce R3 to make it so.

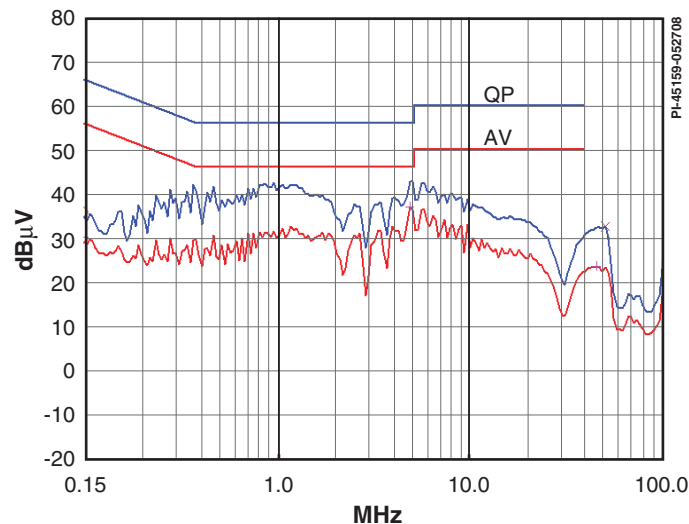

Figure 2. Conducted EMI, 230 VAC Input, EN55015 B Limits, Output RTN Connected to PE.

### Transformer Parameters

<b>Core Material</b>	PC44, gapped for AL of 110 nH/t <sup>2</sup>
<b>Bobbin</b>	Horizontal 10 pin, EE16
<b>Winding Details</b>	Shield: 16T × 2, 32 AWG Primary: 96T, 32 AWG Feedback: 9T × 2, 27 AWG Secondary: 10T, 25 TIW
<b>Winding Order</b>	Shield (1-NC), Primary (2-1), Feedback (4-3), Secondary (9-7)
<b>Primary Inductance</b>	1.13 mH, ±10%
<b>Primary Resonant Frequency</b>	700 kHz (minimum)
<b>Leakage Inductance</b>	80 µH (maximum)

Table 1. Transformer Parameters. (AWG = American Wire Gauge, TIW = Triple Insulated Wire, NC = No Connection)

Power Integrations  
5245 Hellyer Avenue  
San Jose, CA 95138, USA.  
Main: +1 408-414-9200  
Customer Service  
Phone: +1-408-414-9665  
Fax: +1-408-414-9765  
Email: [usasales@powerint.com](mailto:usasales@powerint.com)

On the Web  
[www.powerint.com](http://www.powerint.com)

Power Integrations reserves the right to make changes to its products at any time to improve reliability or manufacturability. Power Integrations does not assume any liability arising from the use of any device or circuit described herein. POWER INTEGRATIONS MAKES NO WARRANTY HEREIN AND SPECIFICALLY DISCLAIMS ALL WARRANTIES INCLUDING, WITHOUT LIMITATION, THE IMPLIED WARRANTIES OF MERCHANTABILITY, FITNESS FOR A PARTICULAR PURPOSE, AND NON-INFRINGEMENT OF THIRD PARTY RIGHTS. The products and applications illustrated herein (transformer construction and circuits external to the products) may be covered by one or more U.S. and foreign patents or potentially by pending U.S. and foreign patent applications assigned to Power Integrations. A complete list of Power Integrations' patents may be found at [www.powerint.com](http://www.powerint.com). Power Integrations grants its customers a license under certain patent rights as set forth at <http://www.powerint.com/ip.htm>.

The PI logo, TOPSwitch, TinySwitch, LinkSwitch, DPA-Switch, PeakSwitch, EcoSmart, Clampless, E-Shield, Filterfuse, StackFET, PI Expert and PI FACTS are trademarks of Power Integrations, Inc. Other trademarks are property of their respective companies. ©2008, Power Integrations, Inc.