

Linear, Fixed, 100mA Constant Current LED Driver

Features

- ▶ 100mA \pm 5% constant current drive
- ▶ Built-in reverse polarity protection
- ▶ Dimmable via PWM supply
- ▶ Overtemperature protection
- ▶ Tab ground allows direct heatsinking to chassis
- ▶ 90V max rating for transient immunity

Applications

- ▶ Flashlights
- ▶ Specialty lighting
- ▶ Low voltage signage
- ▶ Low voltage lighting
- ▶ *This device is not rated for automotive applications*

General Description

The CL6 is a fixed, linear current regulator designed for driving high brightness LEDs at 100mA from nominal 12V, 24V, or 48V supplies. With a maximum rating of 90V, it is able to withstand transients without the need for additional transient protection circuitry.

The CL6 is offered in both TO-252 (D-PAK) and TO-220 packages. The tab on the TO-220 is ground, allowing heatsinking directly to a chassis without the need for electrically insulating spacers.

Overtemperature protection shuts off the LED current when the die temperature rises above 135°C (nominal). Full LED current resumes when the die temperature falls below 105°C (nominal).

Typical Application Circuit

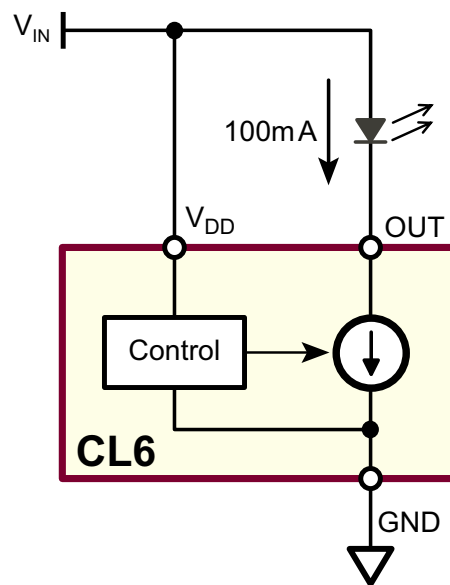

Ordering Information

Device	Package Options	
	TO-252 (D-PAK)	3-Lead TO-220
CL6	CL6K4-G	CL6N5-G

-G indicates package is RoHS compliant ('Green')



Pin Configurations



TO-252 (D-PAK) (K4)

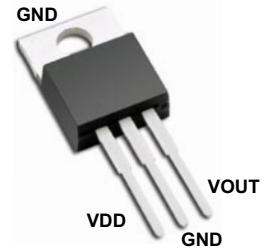

TO-220 (N5)

Pin Designation

Pin	Name	Description
VDD	VDD	Supply voltage for the CL6
OUT	Output	Connect the LED between this pin and the supply voltage
GND	Ground	Circuit common

Absolute Maximum Ratings

Parameter	Value
Supply voltage, V_{DD}	-25V to +100V
Output voltage, V_{OUT}	-25V to +100V
Operating junction temperature*	-40°C
Storage temperature	-65°C to +150°C

Absolute Maximum Ratings are those values beyond which damage to the device may occur. Functional operation under these conditions is not implied. Continuous operation of the device at the absolute rating level may affect device reliability. All voltages are referenced to device ground.

* Maximum junction temperature internally limited.

Product Marking

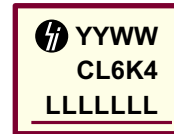

YY = Year Sealed
 WW = Week Sealed
 L = Lot Number
 _____ = "Green" Packaging

3-Lead TO-252 (D-PAK) (K4)

I_{OUT} vs Temperature

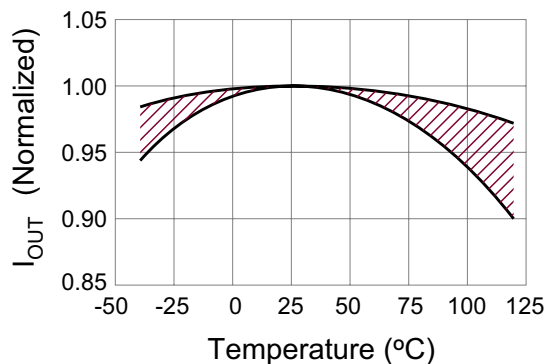

Thermal Characteristics

Guaranteed by design – not production tested

Sym	Parameter	Min	Typ	Max	Units	Conditions
θ_{JC}	Thermal resistance, junction to case	TO-220	-	2.5	-	°C/W
		D-PAK	-	1.3	-	
θ_{JA}	Thermal resistance, junction to ambient	TO-220	-	62	-	°C/W
		D-PAK	-	40	-	
T_{LIM}	Overtemperature limit	120	135	150	°C	---
T_{HYS}	Overtemperature hysteresis	-	30	-	°C	---

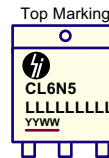

L = Lot Number
 YY = Year Sealed
 WW = Week Sealed
 _____ = "Green" Packaging

3-Lead TO-220 (N5)

Recommended Operating Conditions

(all voltages with respect to GND pin)

Sym	Parameter	Min	Typ	Max	Units	Conditions
V_{DD}	Supply voltage	Normal Extended	6.5 6.5	- 28 90	V	---
V_{OUT}	Voltage at OUT pin ¹	Normal Extended	4.0 4.0	- 28 90	V	---
T_j	Junction temperature ²	-40	-	119	°C	---

Note:

1. Continuous operation at high V_{OUT} voltages may result in activation of overtemperature protection. Use appropriate heatsinking.
2. Maximum junction temperature internally limited.

Electrical Characteristics

(Over normal recommended operating conditions unless otherwise specified. All voltages with respect to GND pin. Production tested @ 25°C.)

Sym	Parameter	Min	Typ	Max	Units	Conditions
I_{DD}	Current into V_{DD} pin	3.0	5.0	10	mA	--
I_{OUT}	Current into OUT pin ⁽³⁾	95 90 50	100 100 -	105 110 120	mA	Normal conditions, 25°C Normal conditions, full temp ⁽⁴⁾ Extended conditions
$I_{OUT(OFF)}$	Current into OUT pin with V_{DD} pin open	-	-	10	µA	V_{DD} = open
V_{OFF}	Voltage at V_{DD} to shut off LED current	-	-	1.0	V	$I_{OUT} < 10\mu A$
t_{ON}	V_{DD} applied on delay	-	-	100	µs	---
t_{OFF}	V_{DD} removed off delay	-	-	100	µs	---

Note:

3. Thermal considerations may limit current to lower values. Use appropriate heat sinking.
4. Guaranteed by design – not production tested.

Application Circuits

Low Current On/Off Control

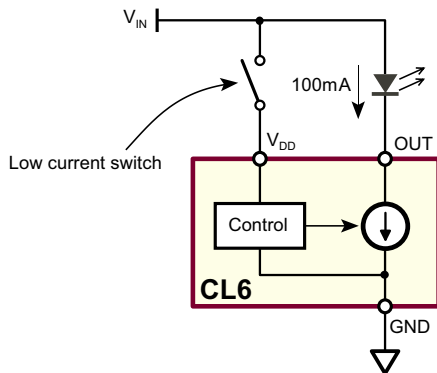

2-Terminal Operation

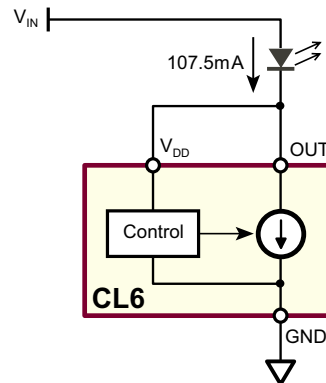

Minimum V_{IN} is increased by LED drop.
 I_{LED} is increased by I_{DD}

3-Lead TO-252 D-PAK Package Outline (K4)

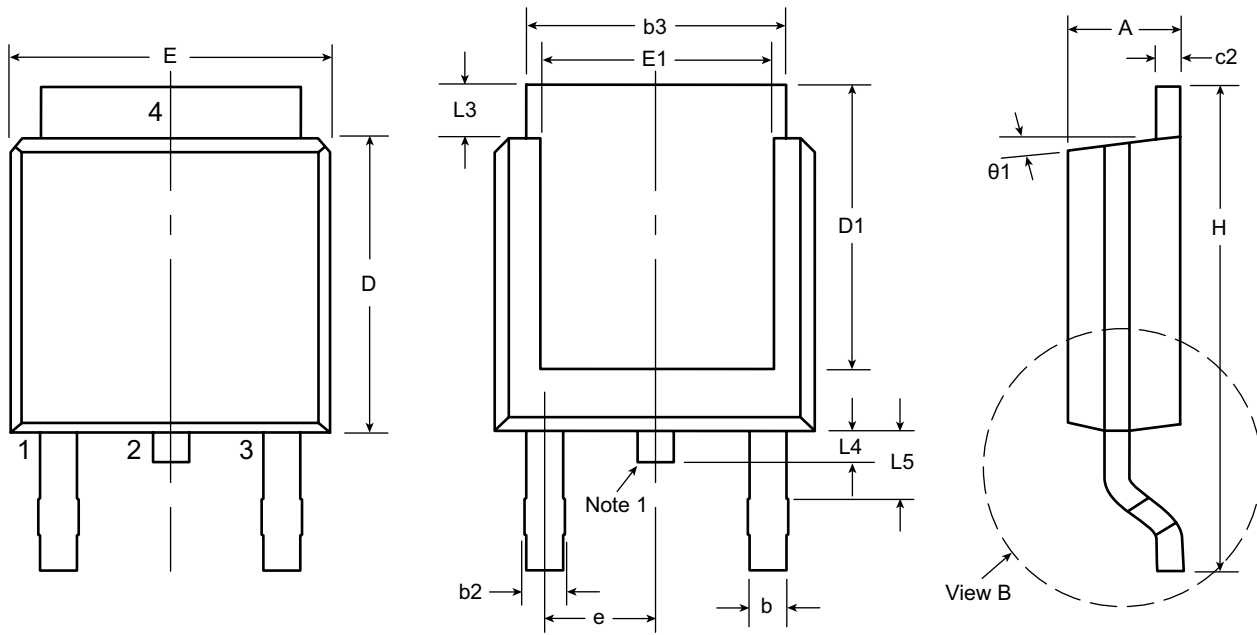

Front View

Rear View

Side View

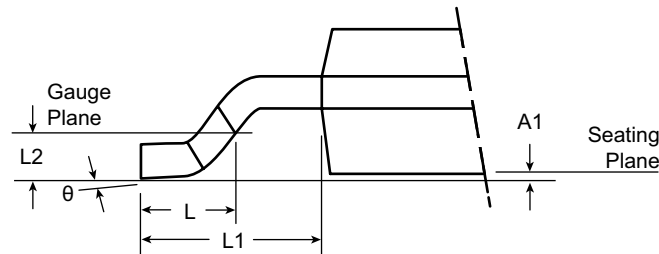

View B

Note:

1. Although 4 terminal locations are shown, only 3 are functional. Lead number 2 was removed.

Symbol	A	A1	b	b2	b3	c2	D	D1	E	E1	e	H	L	L1	L2	L3	L4	L5	θ	θ_1			
Dimension (inches)	MIN	.086	-	.025	.030	.195	.018	.235	.205	.250	.170	.090 BSC	.370	.055	.108 REF	.020 BSC	.035	-	.045	0°	0°		
	NOM	-	-	-	-	-	.240	-	-	-	-		-	.060			-	-	-	-	-	-	-
	MAX	.094	.005	.035	.045	.215	.035	.245	-	.265	-		.410	.070			-	-	.050	.040	.060	10°	15°

JEDEC Registration TO-252, Variation AA, Issue E, June 2004.

Drawings not to scale.

Supertex Doc. #: DSPD-3TO252K4, Version D070308.

3-Lead TO-220 Package Outline (N5)

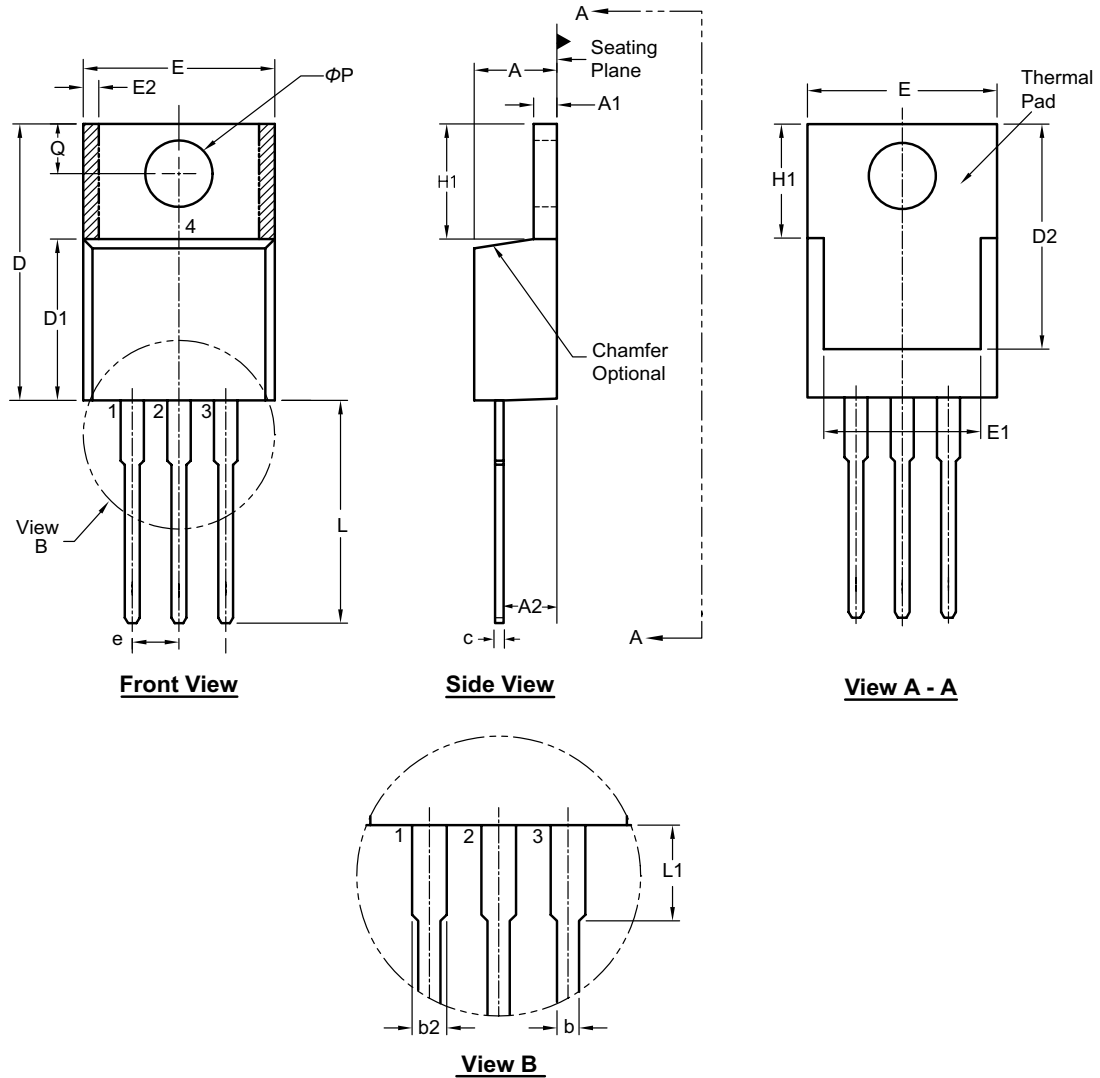

Symbol	A	A1	A2	b	b2	c	D	D1	D2	E	E1	E2	e	H1	L	L1	Q	ϕP
Dimension (inches)	MIN	.140	.020	.080	.015	.045	.014	.560	.330	.480	.380	.270	-	.230	.500	-	.100	.139
	NOM	-	-	-	.027	.057	-	-	-	-	-	-	.100	-	-	-	-	-
	MAX	.190	.055	.115	.040	.070	.024	.650	.355	.507	.420	.350	.030	.270	.580	.250	.135	.161

JEDEC Registration TO-220, Variation AB, Issue K, April 2002.

Drawings not to scale.

Supertex Doc. #: DSPD-3TO220N5, Version B070808.

(The package drawing(s) in this data sheet may not reflect the most current specifications. For the latest package outline information go to <http://www.supertex.com/packaging.html>.)

Supertex inc. does not recommend the use of its products in life support applications, and will not knowingly sell them for use in such applications unless it receives an adequate "product liability indemnification insurance agreement." Supertex inc. does not assume responsibility for use of devices described, and limits its liability to the replacement of the devices determined defective due to workmanship. No responsibility is assumed for possible omissions and inaccuracies. Circuitry and specifications are subject to change without notice. For the latest product specifications refer to the Supertex inc. website: <http://www.supertex.com>.