

Simplicity at its best with FINN[®] LED testing

We are all looking for ways to improve our products, and a big part of that means having a great Quality Control process. If you have LEDs on your PCBs and you want to guarantee the right one is in the right place, our FINN[®] products can help.

Early detection is the key to avoiding costly rework and repairs. Utilizing the FINN[®] to test your LEDs is the solution. Whether you are testing one LED or hundreds, our FINN[®] products can provide you with fast, accurate and repeatable LED color verification in any test environment.

The FINN[®] is a compact and durable LED sensor that fits just about anywhere. Test Coach has several configurations to accommodate your every need, including right angle and vertical styles, as well as a FINN[®] without probes.

The FINN[®] does not require power and is so simple to use. When placed in front of an illuminated LED of the corresponding color, the FINN[®] sends a signal through the probe to your test equipment, indicating color and brightness. Your LED test using the FINN[®] is simple to maintain because you control the limits of your Go/No-Go test.



The FINN[®]

- Provides color-specific LED testing for red, green, blue, clear, UV or IR LEDs
- Is a low-cost tool with big QC rewards
- Provides quick, reliable measurements
- Is consistent and accurate to three decimal points
- Offers simplicity of use—no calibration, no additional hardware and no fiber-optic connections required
- Is simple to mount and easy to implement

The FINN[®] is adaptable to any test platform and is great for both functional and ICT fixtures.

Make light work of testing LEDs. Use the FINN[®].

FINN®

PRINCIPLE OF OPERATION

The FINN® is a combination of a photo-sensitive semiconductor and an optical filter. The filter is designed to pass light from the target wavelength (color) and block the light of wavelengths outside that target color. The sensor produces current when excited by the target wavelength of light and creates a voltage across the bias resistor which is then measured by the target test system.

FEATURES

- Output range is 0.0–0.6 volts depending on color and brightness
- No power is necessary
- Small sensor may be easily mounted in fixture near the LEDs
- Readings are taken at a distance of 0.1–0.15 inches from the lens of the LED
- Two wires for the first sensor and one wire for each additional sensor, using a common return
- No need for optical cables and no potentiometers to adjust
- Special infrared FINN® available to detect infrared LEDs or light sources
- Fully automated; no operator action required
- USB data acquisition

PROPERTIES

- Clearance for sensor dimensions—0.25" x 0.40" x 0.15"
- Sockets—Sensor may be mounted using two industry standard 100 mil (2, 54 mm) sockets

SELECTING THE RIGHT FINN®

The FINN® is color-specific. *Example:* Order a red FINN® (TC3001) for a red LED.

LED Color	FINN	Part Number
Red	Red FINN	TC3001xx
Orange	Red FINN	TC3001xx
Yellow	Green FINN	TC2901xx
Green	Green FINN	TC2901xx
Blue	Blue FINN	TC2801xx
Clear	Clear FINN	TC8704xx
Ultraviolet	Clear FINN	TC8704xx
Infrared	IR FINN	TC8708xx

Readings range from 0–600mV, depending on the LED color and intensity. Although the FINN® can be used for yellow and amber LEDs, we recommend using Smart FINN® for these colors.

ORDERING INFORMATION

All FINN® parts are available in right angle (RP), vertical (VP), and probeless (P) configurations. Add the style letters to the end of the part number below to order the correct configuration. *Example:* For a green right angle FINN® to test a surface-mount LED, use part number TC2901RP.

Part Number	Description
TC2901xx	Green
TC3001xx	Red
TC2801xx	Blue
TC8704xx	Clear*
TC8708xx	Infrared

*This part may also be used to test ultraviolet LEDs.

Additional documentation is available for download from our web site.

U.S. Patent No. 6,490,037; international patent pending





TEST COACH CORPORATION

FINN[®]

Manual of Specifications

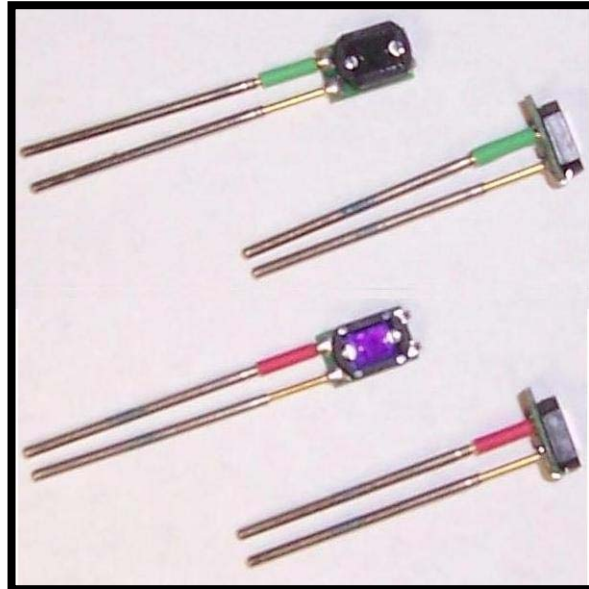

*This file documents the Test Coach Corp. FINN[®] color sensor product.
US patent # US 6,490,037 B1*

Materials and Information Provided for the FINN[®]

1. HP parts description library file (separate file*).
2. HP, GR, or Z1800 sensor tests (separate files*).
3. Instructions for development, integration, adjustment, and fixture construction.

Separate files are available online @

http://www.testcoach.com/finnProducts/FinnGeneral/finn_downloads.htm

Table of Contents

Table of Contents 2

1. Principle of Operation 3

2. Expected Wavelengths 3

3. Typical Readings 4

 3.1 *Reading Distance* 4

 3.2 *High Readings* 4

 3.3 *Options for Bright LEDs* 5

 3.4 *Ambient Light* 5

 3.5 *Important Note for Green / Yellow Distinction* 5

 3.6 *Low Readings* 5

4. Fixture Considerations 5

 4.1 *Sockets* 5

 4.2 *Applications* 6

 4.3 *LEDs emitting light to the side of the PCB – Vertical FINN* 6

 4.4 *HP Programming for Vertical FINN* 6

 4.5 *SMT LEDs emitting light perpendicular to the PCB – Right Angle FINN* 7

 4.6 *HP Programming for the Right Angle FINN* 7

5. Drawings 8

 5.1 *TC2901VP*..... 8

 5.2 *TC2901RP*..... 8

 5.3 *Sensor Detail*..... 9

 5.4 *Probe Detail*..... 9

6. Test Coach Corporation Contact Information 9

1. Principle of Operation

The FINN[®] sensor is a low cost solution for detecting the color of light emitting diodes (LEDs). It is a combination of a photosensitive semiconductor and an optical filter. The filter allows light of a target wavelength (color) to pass through and blocks light of wavelengths outside the target color wavelength. The sensor produces current when excited by the target wavelength of light. The current creates a voltage across the bias resistor, which is measured by the target test system.

The test is easy to adjust and maintain because it uses the tester resources that the test engineer is already familiar with. There are no potentiometers to adjust. Adjusting upper and lower limits in an analog test statement is all that is needed to support most applications.

The sensor is also very small allowing it to be easily mounted in the fixture near the LEDs. There is usually no need for optical cables in the fixture. The sensor does not require power so only two wires are needed per sensor. A common return may be used with high LED count applications to reduce the wire resources to one per sensor plus one for the common return.

2. Expected Wavelengths

LED Color	Nominal Wavelength	FINN [®]	Sensor Peak Sensitivity
			Wavelength / 50% bandwidth
Red	655-700nm	Red -TC3001	660nm - 615-705nm
Orange	605nm	Red - TC3001	660nm - 615-705nm
Yellow	585nm	Green - TC2901	540nm - 505-575nm
Green	560nm	Green - TC2901	540nm - 505-575nm
Blue	450-500nm	Blue - TC2801	460nm - 415-505nm
Any/Clear*	N/A	Clear - TC8704*	560nm – 400-680nm
Infrared	700 – 1100nm	Infrared – TC8708	960nm – 500–1050nm

* TC8704 (Clear FINN[®]) provides intensity readings for all color LEDs, but is not used to distinguish colors.

To understand the above chart only a few terms need to be defined. These definitions are suitable for this discussion, but oversimplified for optical physics. The Nominal Wavelength column gives typical wavelengths emitted by standard LEDs. The Sensor Peak Sensitivity Wavelength is the wavelength at which the sensor generates the most current per light striking the sensors active region. The 50% bandwidth entry is similar to a 3db point of an electronic filter. So, the light of a wavelength on the edge of the 50% bandwidth would produce half the current as the same amount of light at the Peak Sensitivity wavelength.

Example: A red LED may produce enough light on the active region of the red sensor for a voltage of 450mV to be developed across the sensor. A yellow LED with the same light intensity might produce about 120mV and a green or blue LED even less. Setting the test limit at 300mV would guarantee a red LED with a minimum working intensity is installed in the circuit card assembly (CCA).

From the above chart, you can see that it is difficult to detect the difference between green and yellow LEDs. We recommend using a green sensor. All the variables must be optimized and fault insertion must be used to set the limits. Variations from lot to lot may require additional tweaking of the test.

A clear sensor can be used to detect both elements of a bi-color LED turning on. Another way to check a red-green bi-color LED is to use 2 sensors at a 90 degree angle to each other, one sensor green and one sensor red, then position these in front of the LED like a book. We have a specialized variation of the FINN[®] called the Butterfly FINN[®] (TC2930BV or TC2930BR) with a green and red sensor mounted to just 2 probes. The photosensitive areas of the sensors face each other but open like a V. The reading is positive for red and negative for green. These FINN's are currently available for SMT LEDs emitting light perpendicular to the surface of the PCB. If you choose this method for side emitting LEDs it will require a little more fixture setup.

3. Typical Readings

LED Color	Nominal Readings		
	Red FINN [®]	Green FINN [®]	Blue FINN [®]
Red	400mV	Less than 50mV	Less than 50mV
Orange	300mV	Less than 50mV	Less than 50mV
Yellow	200mV	200mV	Less than 50mV
Green	Less than 50mV	300mV	Less than 50mV
Blue/White	N/A	N/A	400mV
Readings are for new FINN [®] resistor values	330k bias	510k bias	1.2Meg bias

Please note that the typical readings listed here are for the new release of the FINNs with sensitivity enhancements. These readings will be slightly different from FINNs purchased prior to January 2002.

3.1 Typical readings are taken at a distance of 0.1 - 0.15 inches from the lens of the LED.

3.2 High Readings

If readings for the target LED color are higher, then the sensor may be close to saturation and effectiveness of the sensor is diminished. In this situation, if possible, adjust the intensity of the LED until the FINN reads the target voltage in the chart.

LED Color	FINN [®] Saturation Voltage	Test Voltage Target	FINN [®] Suggested Limits
Red	550mV	400mV	450 - 350mV
Orange	Using red FINN [®]	300mV	350 - 250mV
Yellow	Using green FINN [®]	200mV	250 - 150mV
Green	390mV	300mV	350 - 270mV
Blue/White	550mV	400mV	450 - 350mV

3.3 *Options for use with bright LEDs:*

1. ***Reduce the intensity of the LED by reducing the drive current.****
2. Cover part of the active area of the sensor to reduce the amount of light entering.
3. Move the FINN[®] away from the LED.
4. Add resistance across the FINN.[®]
5. Adjust the upper and lower limits in the test program.

***This option is preferred. Try this first.**

3.4 *Ambient Light*

With an unlit LED, ambient light should not produce more than a 50mV reading.

If the ambient reading is higher, try reducing the ambient light by shading the test area or by moving the FINN[®] closer to the LED. Ambient light is not usually a problem in in-circuit test fixtures with over-clamps.

3.5 *Important Note for Green / Yellow Distinction*

If you are trying to detect the difference between *green* and *yellow* there must be **no** ambient light.

3.6 *Low Readings*

If readings for the target LED color are lower, then

1. The LED may not be illuminated properly
2. The sensor is not properly placed in front of the LED
3. The voltmeter may not have a high enough input impedance (greater than 5meg ohm).

4. **Fixture Considerations**

4.1 *Sockets*

The sensor is mounted using two 100mil sockets. Industry standard 100mil sockets:

QA part number 100-SDN250W*

ECT part number SPR-25W-2

IDI part number R25W

* For longer set heights QA 100-SDN251W may be useful.

The placement of the pair of sockets is as follows:

- Distance center to center (sockets): 0.125” nominal +/- 0.01”
- Distance from front tip of LED lens to FINN lens: 0.10” nom.
- Distance from tip of LED lens to probes midpoint: 0.21” nom. vertical

The face of the sensor must always be placed to maximize the light from the LED hitting the center of the active region of the sensor.

It is desirable to reduce the ambient light coming in from above the fixture. This may easily be accomplished if there is a hold down gate. Material can be mounted directly on the hold down gate, or if there is a solid lexan plate, then black electrical tape can be used to block the light. The test method is tolerant of small changes of ambient light. However, if the ambient light is close to the intensity of the light from the LEDs then the test will not be reliable.

4.2 Applications

The two most common applications for FINNs are with LEDs on the edge of the board and SMT LEDs, which lay flat on the PCB. Following is a description of each case. For other physical configurations, the sensor can be ordered without probes and the fixture vendor may install short travel probes or 0.025" square wire wrap posts.

4.3 LEDs emitting light to the side of the PCB "Use Part # TCxxxxVP" – Vertical FINN

Recommended distances:

- Sensor lens to lens of LED:
Minimum: 0.10" *Maximum:* 0.15" or more*
 *Depending on strength of light source and ambient light.
- Recommended clearance/ milling:
 - 0.25" minimum (side to side)
 - 0.15" minimum (front to back)
 - 0.50" minimum (leads to top/end)
- Sensor setup:
 - Align the center of the sensor's active region with center of the LED lens.
 - There will be no compression of the probe.

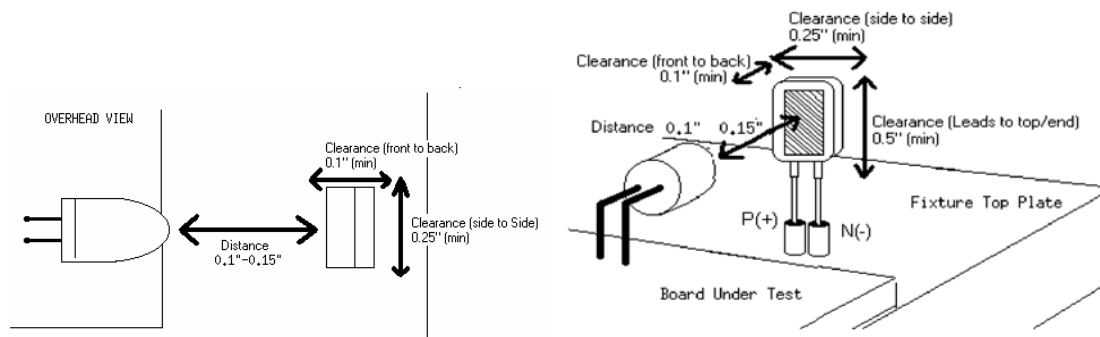

4.4 HP Programming for Vertical FINN®

For the HP programmer only, the following outlines how to set up the part directly in the HP board file and board_xy file.

- ◆ Make the LED a pin library. Then add 2 pins to the device. Name the 2 new pins func_p and func_n. The node names for the 2 pins should be easily identifiable (such as fix_FINN_func_n, fix_led1_func_p). Use a separate node name for each sensor positive pin.
- ◆ Give the part the appropriate part number (i.e. the pde file name: led_grn, led_red ...)
- ◆ Note: The pde file includes a diode test for the LED, self-test for the FINN®, and the actual color sensing test.
- ◆ Calculate the pin x,y locations as below.
- ◆ Find edge of emitting lens or edge of the board. Add 0.1" in the direction away from the PCB for clearance.
- ◆ Find the center of the beam. Add +/-0.0625" perpendicular to the light beam. If the sockets are to be installed in the probe plate then the p-side will be clockwise. If the sockets are to be installed in the over-clamp, the p-side will be counterclockwise.

- ◆ Note: You may need to extend the outline of the board to encompass the probes.

4.5 SMT LEDs emitting light perpendicular to the surface of the PCB “Use Part # TCxxxxRP” – Right Angle FINN®

Recommended distances

- Sensor lens to top of LED:
Minimum: 0.10” *Maximum:* 0.15” or more*
*Depending on strength of light source and ambient light.
- Sensor setup:
 - Seat topside probes so that a 0.250 stroke probe sits above the board 0.15 “ when engaged
 - Probe offsets from center of LED light source
 1. +0.0625” one direction (p or n side probes)
 2. -0.0625” one direction (p or n side probes)

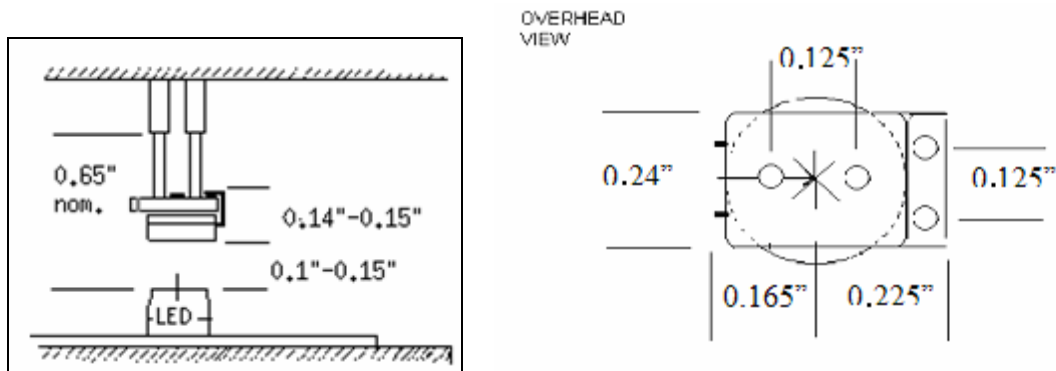

4.6 HP Programming for Right Angle FINN®

For HP programmer only, this is how to set up the part directly in HP board file and board_xy file.

- ◆ Make the LED a pin library. Then add 2 pins to the device. Name the 2 new pins func_p and func_n. The node names for the 2 pins should be easily identifiable (such as fix_FINN_func_n, fix_led1_func_p). Use separate node name for each sensor positive pin.
- ◆ Give the part the appropriate part number (i.e. the pde file name: led_grn, led_red ...)
- ◆ Note: The pde file includes a diode test for the LED, self-test for the FINN, and the actual color sensing test.
- ◆ Calculate the pin x,y locations from drawings above or use the FINN_Calculation basic program provided with the starter kit.

5. Drawings

5.1 TC2901VP – Vertical FINN®

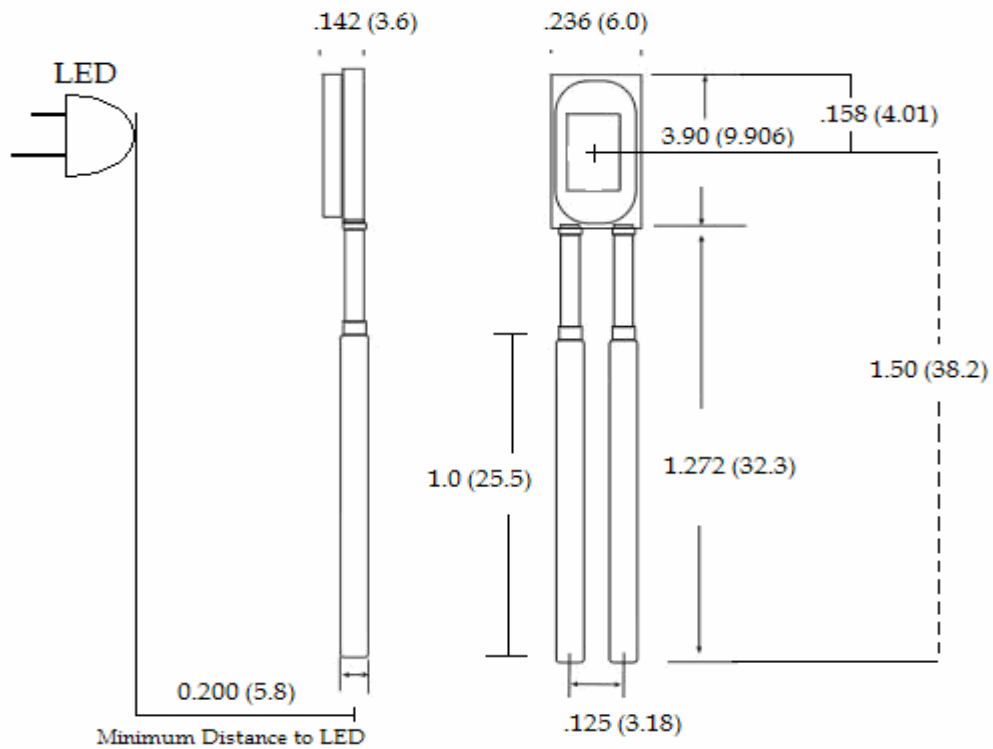

5.2 TC2901RP – Right Angle FINN®

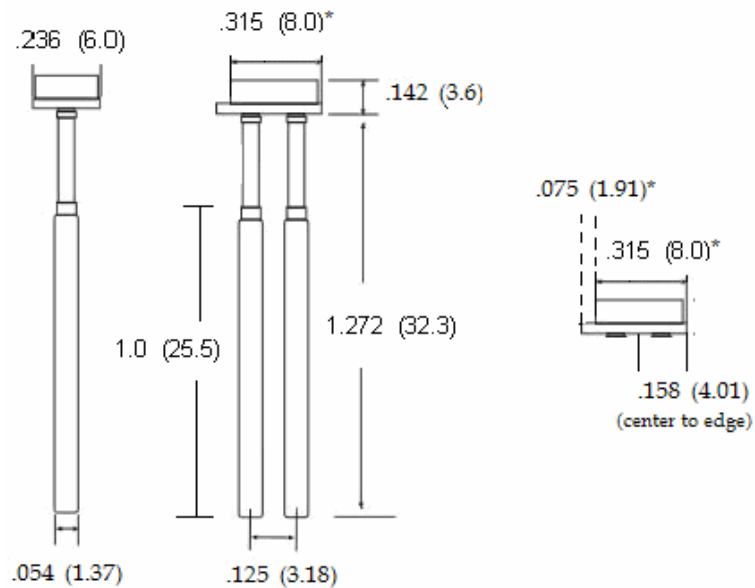

*Length of sensor is .315 (8.0).
 Length from edge of sensor to end of PCB is .075 (1.91).
 Unused length .075 (1.91) may be shaved to accommodate
 space requirements.

Inch (mm)



5.3 Sensor Detail

Sensor dimensions provided are equivalent for both vertical and right angle styles as well as all color options

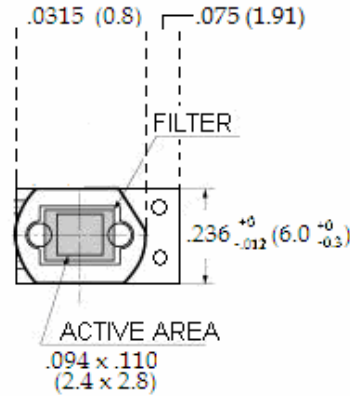

Tolerance unless otherwise noted: + 0.15 (3.81)

Inch (mm)

5.4 Probe Detail

Our FINN[®] sensors use QA Technologies 025-26 series probes. To obtain the appropriate sockets please contact any of the following companies.

<u>Company</u>	<u>Part Number</u>
QA Technologies	100-SDN250W
Everett Charles Technologies	SPR 25W2
INGUN	KS 925 47 G
IDI	R100WW

6. Test Coach Corporation Contact Information

Test Coach Corporation
 2400 W. Hassell Road Suite 310
 Hoffman Estates, IL 60195
 (847)885-4880
<http://www.testcoachcorp.com>
corinnew@testcoachcorp.com

