

SPECIFICATIONS FOR UPEC FLUX TYPE BLUE LED

MODEL: UE-FR300NB0-1TJ

Features

- High intensity
- General purpose leads
- Reliable and rugged

Package Dimensions

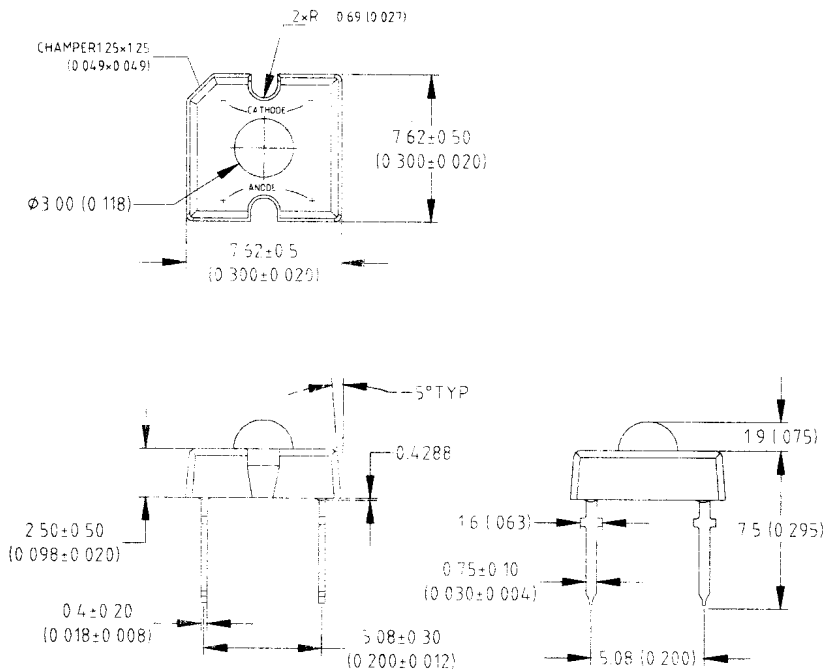

Part NO.	Chip Material	Lens Color	Source Color
UE-FR300NB0-1TJ	InGaN	Water Clear	Blue

Notes

- All dimensions are in millimeters (inches).
- Tolerance is ± 0.25 mm ($.010$ ") unless otherwise noted.
- Protruded resin under flange is 1.0mm ($.04$ ") max.
- Lead spacing is measured where the leads emerge from the package.
- Specifications are subject to change without notice.
- Precautions for ESD:
STATIC SHIELD Electricity and surge damages the LED. It is recommended to use a wrist band or anti-electrostatic glove when handling the LED. All devices, equipment and machinery must be properly grounded.
- This data-sheet only valid for six months.

			Approved	Checked	Symbol	UPEC LED
			Justin 06/11/2004	Tsai 6/11	Name	UE-FR300NB0-1TJ
A	JUN/07/04	Drawing No			WIENDS 123	
Mark	Date	Description			Approv.	

Absolute Maximum Ratings at Ta=25°C

Parameter	Symbol	Max	Unit
Power Dissipation	PD	120	mW
Pulse Forward Current	IPF	100	mA
Forward Current	IF	30	mA
Reverse Voltage	VR	5	V
Operating Temperature Range	Topr	- 40 to + 80	°C
Storage Temperature Range	Tstg	- 40 to + 80	°C
Lead Soldering Temperature [1.6mm (0.063inch) From Body] 260 °C For 5 Seconds			

Electrical / Optical Characteristics at Ta=25°C

Parameter	Symbol	Min.	Typ.	Max.	Unit	Test Condition
Luminous Intensity	Iv	140	450	900	mcd	I _f =20mA (Note 1)
Viewing Angle	2θ _{1/2}	---	55	---	Deg	(Note 2)
Dominant Wavelength	λ _d	---	470	---	nm	I _f =20mA (Note 3)
Forward Voltage	V _F	---	3.5	4.0	V	I _f = 20mA
Reverse Current	I _R	---	---	100	μA	V _R = 5V

BIN	LK	LL	LM	LN	LO	---
Range	140-210	210-310	310-460	460-690	690-1000	---

Measurement Uncertainty of the Luminous Intensity: ± 15%

Notes

- Luminous intensity is measured with a light sensor and filter combination that approximates the CIE eye-response curve.
- θ_{1/2} is the off-axis angle at which the luminous intensity is half the axial luminous intensity.
- The dominant wavelength (λ_d) is derived from the CIE chromaticity diagram and represents the single wavelength which defines the color of the device.

			Approved	Checked	Symbol	UPEC LED
			Justin	Tsai	Name	UE-FR300NB0-1TJ
A	JUN/07/04	Description Appr. O.			Drawing No	WIENDS123
Mark	Date					

Typical Electrical / Optical Characteristics Curves

Spectrum Distribution

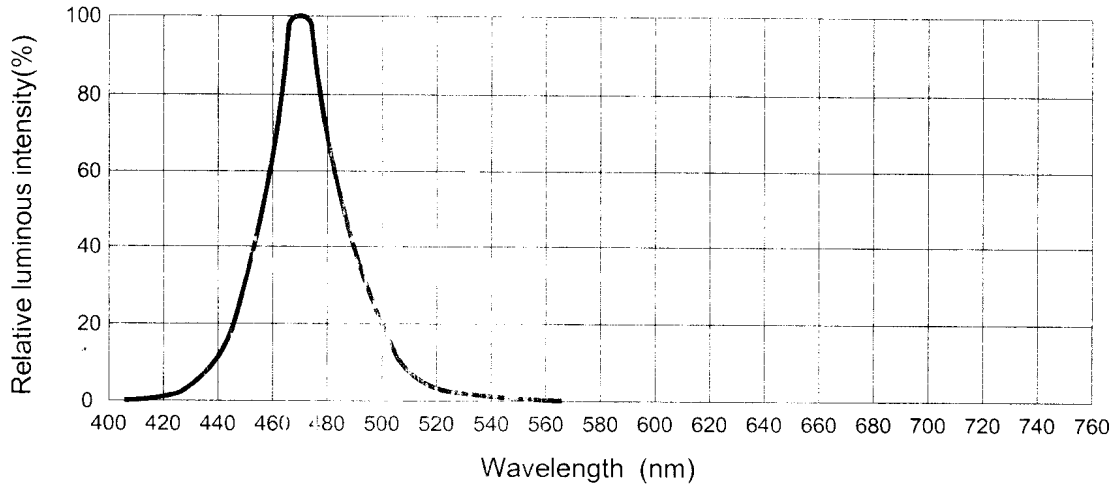

Forward Current VS. Forward Voltage

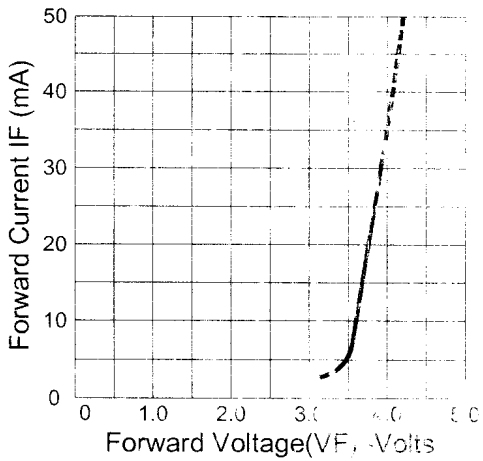

Luminous Intensity VS. Forward Current

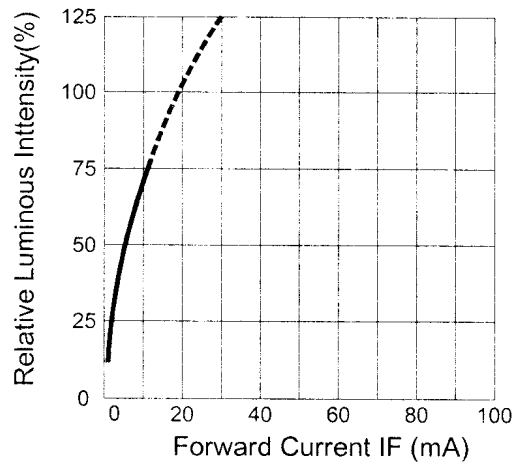

Forward Current VS. Ambient Temperature

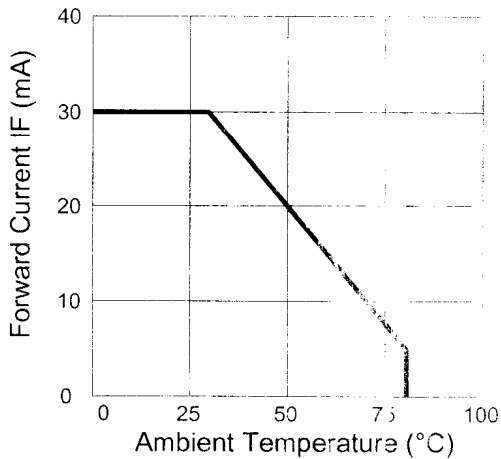

Radiation Diagram

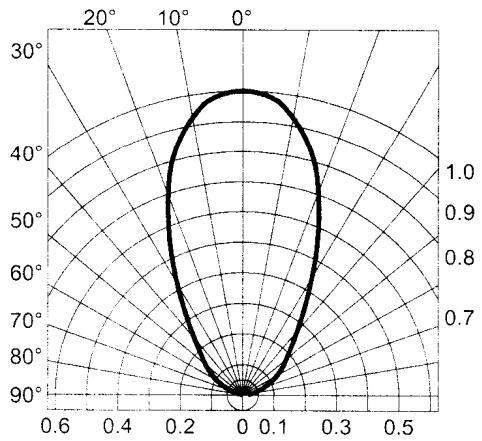

			Approved	Checked	Symbol	UPEC LED
					Name	UE-FR300NB0-1TJ
A	JUN/07/04		Justin	Tsai	Drawing No	WIENDS123
Mark	Date	Description	Appro.			

Reliability Test Items and Conditions

No.	Item	Test Conditions	Test Hours/Cycle	Sample Q'ty	Ac/Re
1	Solder Heat	TEMP : 260°C±5°C	5 sec	22 pcs	0/1
2	Temperature Cycle	H : +85°C 30min. § 5min. L : -35°C 30min.	50 cycle	22 pcs	0/1
3	Thermal Shock	H : +85°C § 5min. L : -35°C 5min.	50 cycle	22 pcs	0/1
4	High Temperature Storage	TEMP : 85°C	1000 hrs	22 pcs	0/1
5	Low Temperature Storage	TEMP : -35°C	1000 hrs	22 pcs	0/1
6	DC Operating Life	I _f = 20mA	1000 hrs	22 pcs	0/1
7	High Temperature/High Humidity	65°C/85~90%R.H.	1000 hrs	22 pcs	0/1

Judgment Criteria

Forward Voltage Vf	Vf _{max} Increase <1.2x
Reverse Current Ir	Ir _{max} Increase <2x
Luminous Intensity Iv	Iv Decay < 50%

Note : Measurement shall be taken after the tested samples have been returned to normal ambient conditions (generally after two hours)

			Approved	Checked	Symbol	UPEC LED
					Name	UE-FR300NB0-1TJ
A	JUN/07/04		Justin	Tsai	Drawing No	WIENDS123
Mark	Date	Description	Appro.			