

SPECIFICATIONS FOR UPEC LAMP TYPE YELLOW LED

MODEL: UE-LR500NY0-1XB

Features

- High Luminous intensity
- Standard T-1 3/4 diameter package
- General purpose leads
- Reliable and rugged

Package Dimensions

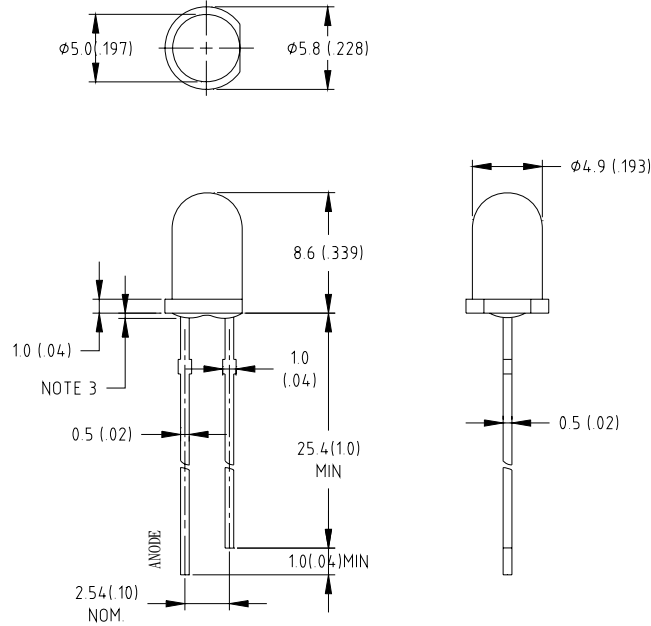

Part NO.	Chip Material	Lens Color	Source Color
UE-LR500NY0-1XB	AlGaInP	Water Clear	Yellow

Notes

1. All dimensions are in millimeters (inches).
2. Tolerance is $\pm 0.25\text{mm}$ (.010") unless otherwise noted.
3. Protruded resin under flange is 1.5mm (.06") max.
4. Lead spacing is measured where the leads emerge from the package.

			Approved	Checked	Symbol	UPEC LED
			Ryan	Afra	Name	UE-LR500NY0-1XB
A	JUL/13/06	内容修改				
-	APR/18/05	新制定				
Mark	Date	Description Approve.			Drawing No	

Absolute Maximum Ratings at Ta=25°C

Parameter	Symbol	Max	Unit
Power Dissipation	PD	90	mW
Pulse Forward Current	IPF	100	mA
Forward Current	IF	35	mA
Reverse Voltage	VR	5	V
Operating Temperature Range	Topr	- 30 to + 80	°C
Storage Temperature Range	Tstg	- 40 to + 100	°C
Lead Soldering Temperature [1.6mm (0.063inch) From Body] 260 °C For 5 Seconds			

Electrical / Optical Characteristics at Ta=25°C

Parameter	Symbol	Min.	Typ.	Max.	Unit	Test Condition
Luminous Intensity	Iv	7300	18000	---	mcd	IF = 20mA
Viewing Angle	2θ _{1/2}	---	15	---	Deg	IF = 20mA
Dominant Wavelength	λ _d	---	591	---	nm	IF = 20mA
Forward Voltage	V _F	---	2.1	2.5	V	IF = 20mA
Reverse Current	I _R	---	---	50	μA	VR = 5V

BIN	LU	LV	LW	---	---	---
Range	7300-11000	11000-16500	16500-25000	---	---	---

Measurement Uncertainty of the Luminous Intensity: ± 15%

Measurement Uncertainty of the Dominant Wavelength: ±1nm

Measurement Uncertainty of the Forward Voltage: ±0.1V

Notes

- Luminous intensity is measured with a light sensor and filter combination that approximates the CIE eye-response curve.
- θ_{1/2} is the off-axis angle at which the luminous intensity is half the axial luminous intensity.
- The dominant wavelength (λ_d) is derived from the CIE chromaticity diagram and represents the single wavelength which defines the color of the device.

			Approved	Checked	Symbol	UPEC LED
			Ryan	Afra	Name	UE-LR500NY0-1XB
A	JUL/13/06	内容修改				
-	APR/18/05	新制定				
Mark	Date	Description Approve.			Drawing No	

Typical Electrical / Optical Characteristics Curves

Spectrum Distribution

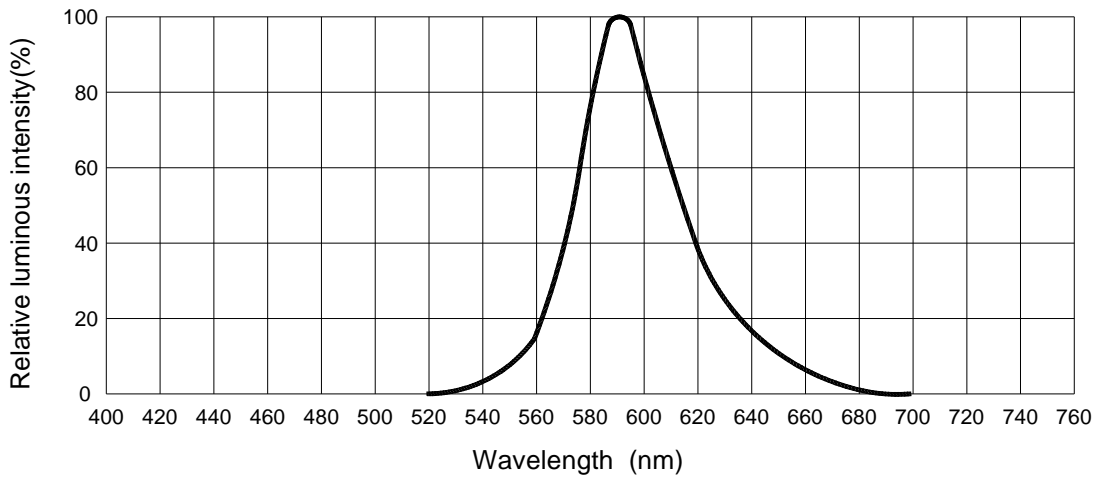

Forward Current VS. Forward Voltage

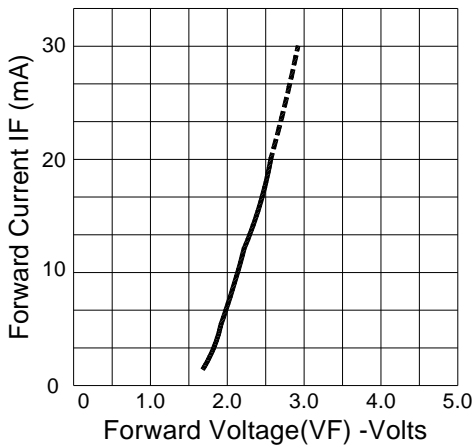

Luminous Intensity VS. Forward Current

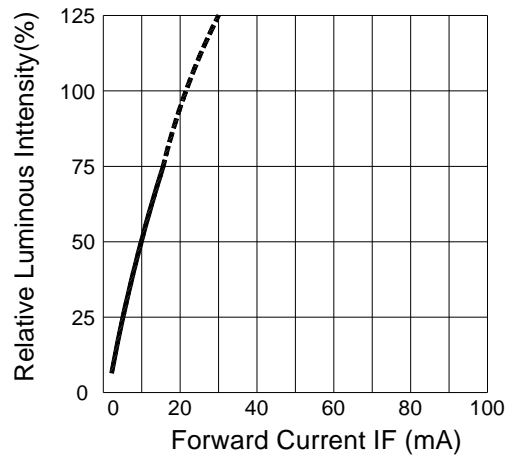

Forward Current VS. Ambient Temperature

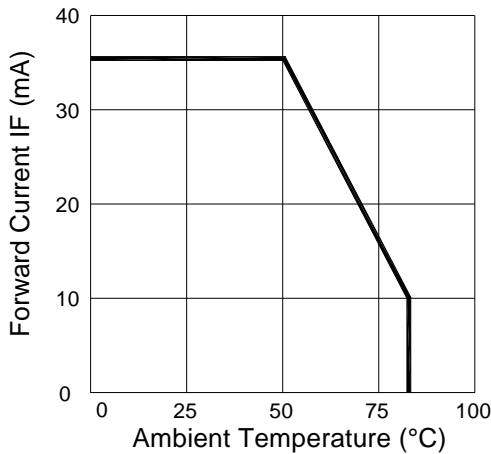

Radiation Diagram

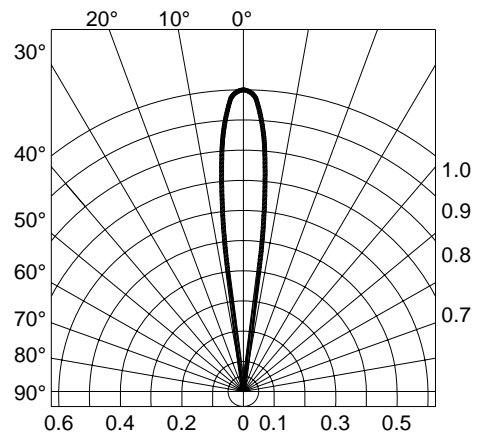

			Approved	Checked	Symbol	UPEC LED
			Ryan	Afra	Name	UE-LR500NY0-1XB
A	JUL/13/06	内容修改			Drawing No	
-	APR/18/05	新制定				
Mark	Date	Description Approve.				

Reliability Test Items and Conditions

No.	Item	Test Conditions	Test Hours / Cycle	Sample Q'ty	Ac/Re
1	Solder Heat	TEMP : 260°C±5°C	5 sec	22 pcs	0/1
2	Temperature Cycle	H : +85°C 30min. ∫ 5min. L : -35°C 30min.	50 cycle	22 pcs	0/1
3	Thermal Shock	H : +85°C ∫ 5min. L : -35°C 5min.	50 cycle	22 pcs	0/1
4	High Temperature Storage	TEMP : 85°C	1000 hrs	22 pcs	0/1
5	Low Temperature Storage	TEMP : -35°C	1000 hrs	22 pcs	0/1
6	DC Operating Life	I _F = 20mA	1000 hrs	22 pcs	0/1
7	High Temperature / High Humidity	65°C/85~90%R.H.	1000 hrs	22 pcs	0/1

Judgment Criteria

Forward Voltage Vf	V _{fmax} Increase <1.2x
Reverse Current Ir	I _{rmax} Increase <2x
Luminous Intensity Iv	Iv Decay < 50%

Note : Measurement shall be taken after the tested samples have been returned to normal ambient conditions (generally after two hours)

			Approved	Checked	Symbol	UPEC LED
			Ryan	Afra	Name	UE-LR500NY0-1XB
A	JUL/13/06	内容修改				
-	APR/18/05	新制定				
Mark	Date	Description Approve.			Drawing No	