

SPECIFICATIONS FOR UPEC LAMP TYPE ORANGE LED

MODEL: UE-LR300NO0-1XI

CONFIDENTIAL

Features

- High Luminous intensity
- General purpose leads
- Reliable and rugged

Package Dimensions

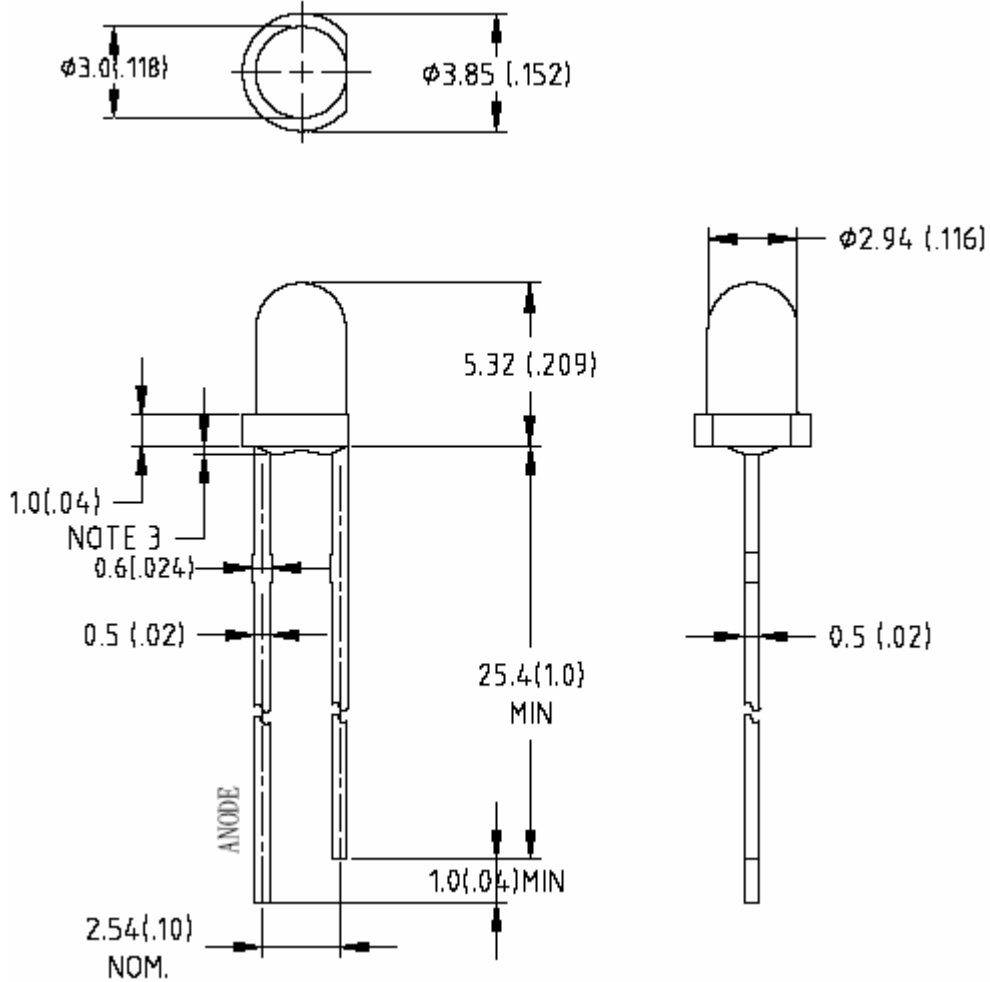

Part NO.	Chip Material	Lens Color	Source Color
UE-LR300NO0-1XI	AlGaInP	Water Clear	Orange

Notes

- All dimensions are in millimeters (inches).
- Tolerance is $\pm 0.25\text{mm}$ (.010") unless otherwise noted.
- Protruded resin under flange is 1.5mm (.06") max.
- Lead spacing is measured where the leads emerge from the package.

			Approved	Checked	Symbol	UPECLEd
			FERRE	AFRA	Name	UE-LR300NO0-1XI
-	Sep/26/06	New			Drawing No	
Mark	Date	Description Approve				

Absolute Maximum Ratings at Ta=25°C

Parameter	Symbol	Max	Unit
Power Dissipation	PD	90	mW
Pulse Forward Current	IPF	100	mA
Forward Current	IF	35	mA
Reverse Voltage	VR	5	V
Operating Temperature Range	Topr	- 40 to + 80	°C
Storage Temperature Range	Tstg	- 40 to + 80	°C
Lead Soldering Temperature [1.6mm (0.063inch) From Body] 260 °C For 5 Seconds			

Electrical / Optical Characteristics at Ta=25°C

Parameter	Symbol	Min.	Typ.	Max.	Unit	Test Condition
Luminous Intensity	Iv	220	380	850	mcd	IF = 20mA
Dominant Wavelength	λd	600	605	610	nm	IF = 20mA
Viewing Angle	$2\theta_{1/2}$	50	60	70	Deg	IF = 20mA
Forward Voltage	VF	1.6	1.9	2.5	V	IF = 20mA
Reverse Current	IR	---	---	100	µA	VR = 5V

BIN	LL	LM	LO	LP	---	---
Range	210-310	310-460	460-690	690-1000	---	---

Measurement Uncertainty of the Luminous Intensity: $\pm 15\%$

Measurement Uncertainty of the Forward Voltage: $\pm 0.1V$

Notes

- Luminous intensity is measured with a light sensor and filter combination that approximates the CIE eye-response curve.
- $\theta_{1/2}$ is the off-axis angle at which the luminous intensity is half the axial luminous intensity.

			Approved	Checked	Symbol	UPECLD
			FERRE	AFRA	Name	UE-LR300NO0-1XI
					Drawing No	
-	Sep/26/06	New				
Mark	Date	Description Approve				

Typical Electrical / Optical Characteristics Curves

Spectrum Distribution

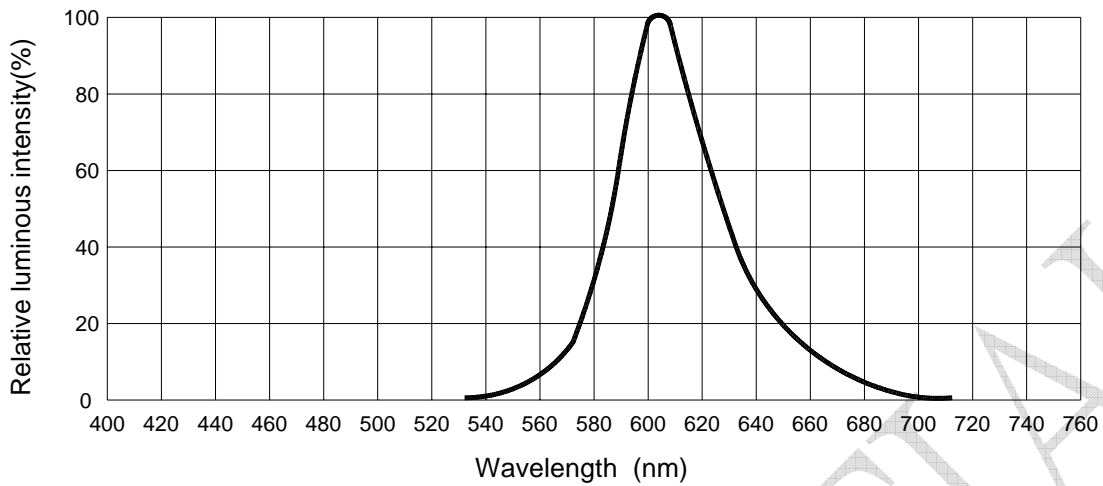

Forward Current VS. Forward Voltage

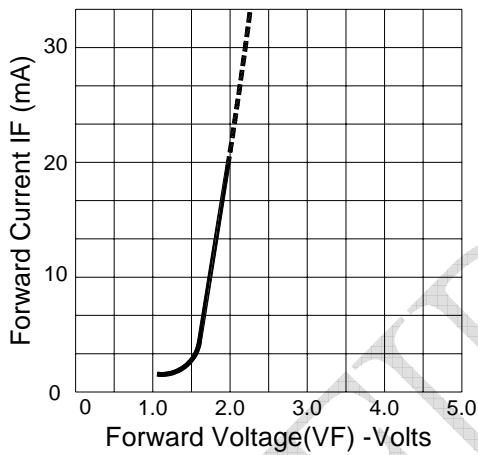

Luminous Intensity VS. Forward Current

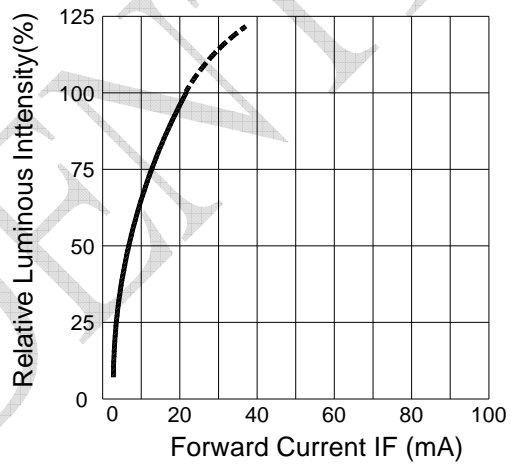

Forward Current VS. Ambient Temperature

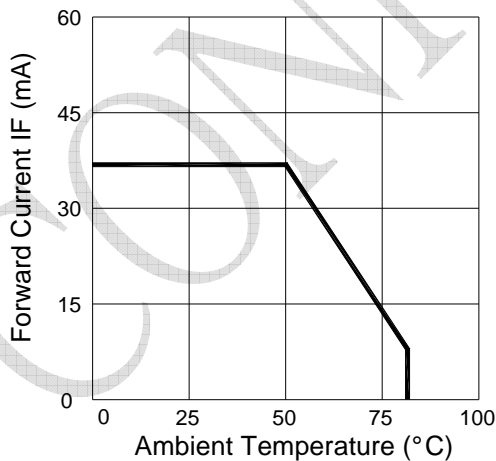

Radiation Diagram

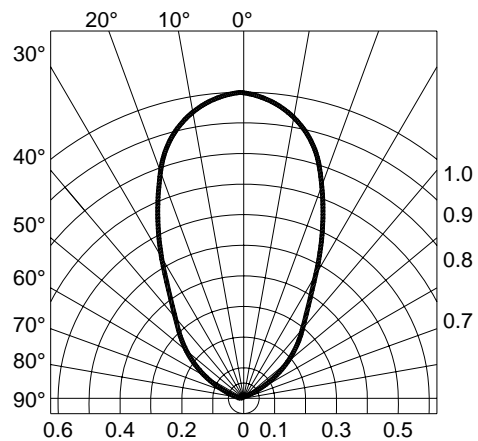

			Approved	Checked	Symbol	UPECLD
			FERRE	AFRA	Name	UE-LR300N00-1XI
-	Sep/26/06	New			Drawing No	
Mark	Date	Description Approve				

Reliability Test Items and Condition

No.	Item	Test Conditions	Test Hours / Cycle	Sample Q'ty	Ac/Re
1	Solder Heat	TEMP : 260°C±5°C	5 sec	30 pcs	0/1
2	Temperature Cycle	H : +85°C 30min. ∫ 5min. L : -35°C 30min.	50 cycle	30 pcs	0/1
3	Thermal Shock	H : +85°C ∫ 5min. L : -35°C 5min.	50 cycle	30 pcs	0/1
4	DC Operating Life	I _F = 20mA	1000 hrs	30 pcs	0/1
5	High Temperature / High Humidity	65°C/85~90%R.H.	1000 hrs	30 pcs	0/1

Judgment Criteria

Forward Voltage Vf	Vf _{max} Increase <1.2x
Reverse Current Ir	Ir _{max} Increase <2x
Luminous Intensity Iv	Iv Decay < 50%

Note : Measurement shall be taken after the tested samples have been returned to normal ambient conditions (generally after two hours)

			Approved	Checked	Symbol	UPECLD
			FERRE	AFRA	Name	UE-LR300NO0-1XI
-	Sep/26/06	New			Drawing No	
Mark	Date	Description Approve				