

It's hard to keep track of how many running text displays you run across nowadays. You can find them used as decorations in shop windows, as programmable signboards and as simple eye-catchers. If you buy one ready-made, however, it's fairly expensive, and they are usually too complex for DIY construction. The running text display project in this article combines a simple and inexpensive design with repeatable construction and ease of use.

Design by K. Wohlrabe

# running text display

controlled by a COP-8 microcontroller

## Technical specifications

Stored text:	508 characters maximum
Displayed text:	6 characters visible using 5 x 7 matrix elements
Transmitter range:	approximately 10 m
Operating voltage:	12 V (transmitter and receiver)



The objective of the running text display project was to develop a simple, inexpensive design that would not be too difficult to build and would be easy to use. We intentionally decided not to make the display as large as possible or to implement a lot of different display modes, since these would require a powerful microcontroller or a single-board computer. The result is a circuit that is controlled by an inexpensive National Semiconductor microcontroller with 4 kB of ROM, and which can be built using readily obtainable components.

Conventional running text displays normally have keyboards that are directly cabled to the display units. These keyboards are usually not laid out the same as standard keyboards, so programming is awkward and time consuming. The keyboard matrix also requires a relatively large printed circuit board with expensive keys, which makes it unsuitable for a DIY project. The basic idea of this project is to use a standard PC keyboard with an infrared data link to the display unit. The running text can then be conveniently programmed, with all the advantages of using a standardised PC keyboard — and this can be done up to 10 metres away from the display.

The transmitter, with its attached keyboard, can also be employed as a general-purpose unit for other (future) projects, in order to simplify the con-

## COMPONENTS LIST (transmitter)

### Resistors:

R1 = 10 $\Omega$   
R2 = 100k $\Omega$   
R3 = 470 $\Omega$   
R4 = 1M $\Omega$

### Capacitors:

C1, C2 = 33pF  
C3 = 100nF  
C4 = 220 $\mu$ F 16V

### Semiconductors:

D1 = TSUB8201  
T1 = ZTX603  
IC1 = COP8782 (order code 996527-1)  
IC2 = 7805  
IC3 = ZSM560

### Miscellaneous:

K1 = 5-way DIN socket 180° or PS2-socket  
X1 = 10MHz quartz crystal

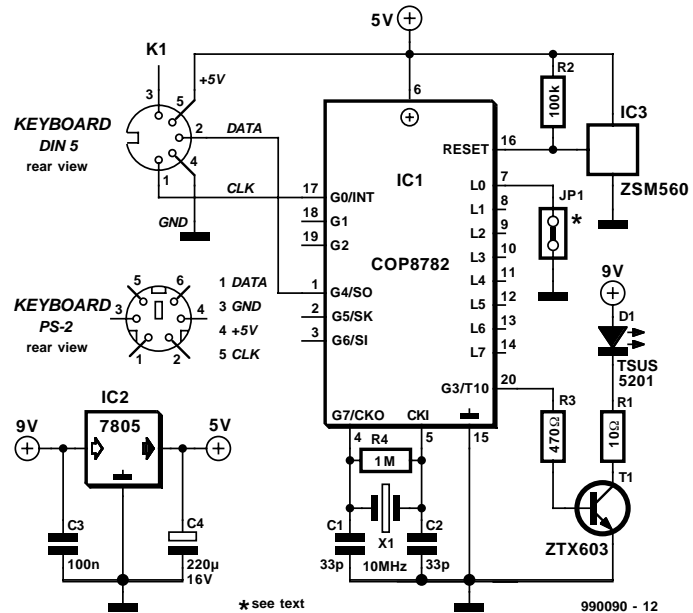

Figure 1. The input data transmitter contains only a COP-8 microcontroller and an infrared transmitter module.

struction and operation of the equipment. Only one port pin of the microcontroller on the receiver side is needed for decoding the information from up to 128 keys.

## The transmitter

The microcontroller in the transmitter unit, whose schematic diagram is shown in **Figure 1**, receives the serial digital signals from the PC keyboard and converts them into a protocol that is sent to the display unit via infrared light. The decoding of PC keyboard signals is described in another article, elsewhere in this issue. The microcontroller in the transmitter unit selects scan code set 3 after it has been reset, switches on the Scroll LED of the keyboard as an indication that it is active, suppresses the Break code for the upper-case (shifted) keys and transfers key codes to the display unit. The data transfer employs a modulated 36 kHz carrier, in order to provide noise immu-

## The microcontroller

The same type of microcontroller is used in the transmitter and the receiver. The specifications of this National Semiconductor IC make it an outstanding choice for this project:

- ◆ 4096 x 8 OTP EPROM
- ◆ 128 bytes of RAM
- ◆ 1  $\mu$ s cycle time at 10 MHz
- ◆ 16-bit timer with the following operating modes:
  - ◆ auto reload
  - ◆ external event counter
  - ◆ timer with capture function
- ◆ 16 I/O leads, of which 14 can individually be programmed as inputs or outputs
  - ◆ selectable pin configuration: tri-state, push-pull or pull-up
- ◆ Microwire interface
- ◆ interrupt sources: external with selectable edge, timer or software

The COP8782 microcontroller now has a successor, with the type designation COP8SAC7. This has improved characteristics, but it is essentially pin-compatible and functionally compatible with the older version. There is a starter kit available, which unfortunately does not allow real-time emulation, but which does allow OTP devices to be programmed. It also provides comprehensive insight into the possibilities of this inexpensive and technically interesting microcontroller family. For somewhat more demanding projects that require the real-time behaviour of the microcontroller to be tested, you have no other choice than to buy an emulator if you do not want your projects to turn into endless trial-and-error sessions.

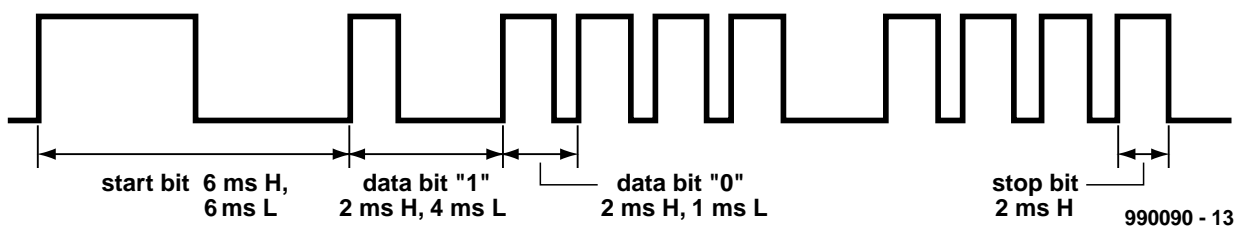

Figure 2. Timing diagram of the transmitter signal that modulates the 36-kHz carrier (this example is for the code 88<sub>H</sub>).

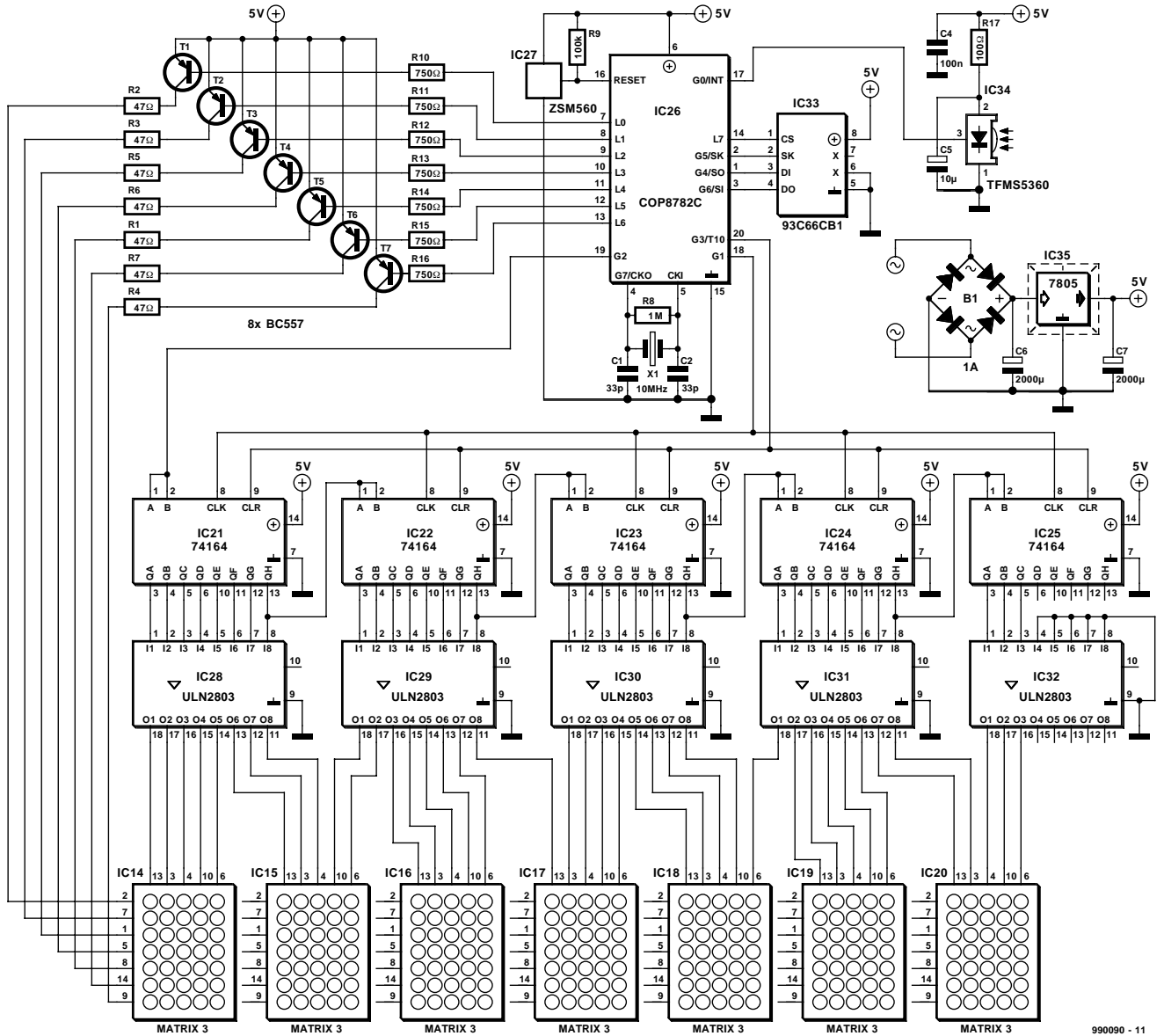

Figure 3. Circuit diagram of the receiver and seven-position LED display matrix.

nity. One start bit, eight data bits, one parity bit and one stop bit are transmitted. The microcontroller is clocked at the relatively high rate of 10 MHz. This enables it to correctly decode the serial data stream from the keyboard, and to generate the 36 kHz carrier frequency for the infrared diode, using only software.

Figure 2 shows the timing diagram of a sample character (with the code 88<sub>H</sub>) before modulation. The infrared diode D1 is driven by the Darlington transistor T1. In order to give the transmitter a wide range, the value of the current-limiting resistor R1 is intentionally chosen to be on the low side, and a high-efficiency LED is used. However, in principle any type of infrared LED can be used.

The short data packets, and the

resulting short 'on' times, prevent the transistor from becoming overheated. The reset IC (IC3) ensures that the microcontroller always starts up properly. The current consumption of the transmitter, including the connected keyboard, is around 110mA. Since it is used only infrequently, it can be powered from a 9 V battery, although a mains adapter can also be used.

### The receiver

The transmitted information is demodulated by the infrared receiver IC4, shown in Figure 3. This very sensitive IC, which is specially tuned to work at the 36 kHz carrier frequency, contains a photodiode, an amplifier stage, a filter and a demodulator. Resistor R17 and capacitor C5 form a supplementary

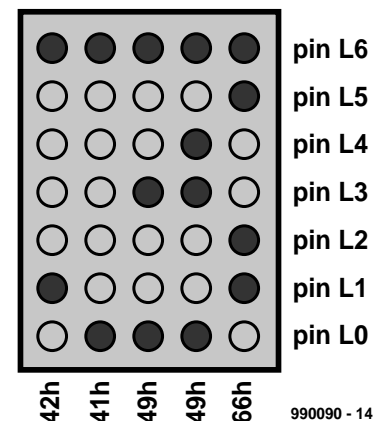

Figure 4. How the numeral '3' is represented on a 5 x 7 matrix display element.

## COMPONENTS LIST

(receiver)

### Resistors:

R1-R7 = 47Ω

R8 = 1MΩ

R9 = 100kΩ

R10-R16 = 750Ω

R17 = 100Ω

### Capacitors:

C1,C2 = 33pF

C4 = 100nF

C5 = 10μF 16V

C6 = 2000μF 25V (or 2200μF 25V)

C7 = 2000μF 16 V (or 2200μF 16V)

### Semiconductors:

B1 = bridge rectifier B80C1000 (80V piv, 1A)

T1-T7 = BC557

IC14-IC20 = see text

IC21-IC25 = 74164

IC26 = COP8782C

(order code 996527-2)

IC27 = ZSM560

IC28-IC32 = ULN2803 (Sprague)

IC33 = 93C66CB1 (ST-Microelectronics)

IC34 = TFMS5360

IC35 = 7805

### Miscellaneous:

Mains adaptor socket

Small heatsink for IC35

X1 = 10MHz quartz crystal

Disk. source code file, order code

996032-1

low-pass filter, which guarantees error-free reception. The microcontroller (IC26) samples the signal every 400 μs. Any transient interference that might be present is suppressed by a special software algorithm, which evaluates the lengths of both the pulses and the intervening gaps and compares them to reference values. Finally, the software computes the parity of the received data and compares this to the state of the received parity bit.

LED matrix display devices with a 5×7 matrix are used for representing the characters. Although a LED matrix display costs marginally more than a set of 35 separate LEDs, it is significantly easier to handle. Since not all of the matrix diodes can be driven at the same time, they must be switched on sequentially using a multiplexing process, which is not noticeable to the user. Seven LEDs at most in one matrix column, are illuminated at any one time. Since the eye cannot respond as fast as the individual segments are switched on and off, it sees an image consisting of 245 points (7×35).

Each display cycle starts with a high level on the data input of the first shift register (IC21). This high level lasts for one clock period. The five cascaded shift registers are clocked simultaneously every 400 μs under interrupt control, so that the active column moves stepwise from QA of IC21 through to QH of IC25. IC28 through IC32 are simple driver ICs, which provide sufficient current for the matrices. Every column of the matrix is assigned to a RAM location in the microcontroller. The information to be displayed appears for 400 μs on the microcontroller outputs L0 through L6, according to which column is being driven. Transistors T1 through T7 are used here as drivers. Due to the use of multiplexing, the LEDs must be driven at higher than usual current levels in order to make them bright enough to be seen in daylight. To obtain sufficient brightness, you should use matrix displays with an optical efficiency of at least 3 mcd at 20 mA.

The information for the running text display is stored in a non-volatile 512-byte serial EEPROM (IC33). In order to allow the data to be quickly recalled, the EEPROM is addressed via the Microwire interface of the microcontroller at a clock frequency of 500kHz. The PC keyboard delivers the scan code of each key via the infrared interface, for example the code 26<sub>H</sub> for the numeral '3'. In order to display this numeral on a 5×7 matrix, as shown in Figure 4, the scan code is converted using a look-up table, which in this case yields the values 42<sub>H</sub>, 41<sub>H</sub>, 49<sub>H</sub>, 59<sub>H</sub> and 66<sub>H</sub>. These are applied to each column in turn to display a '3'. IC36 is a ZSM560, which produces the power-on reset pulse for the microcontroller. The same type of IC is used in the transmitter circuit.

The current consumption of the receiver is around 25 mA when all displays are dark, and around 100 mA (average) to 200 mA (peak) when the display is operating. Here the use of a small battery is not such a good idea. A 12-V mains adaptor is a suitable

power source, or a small 12-V sealed lead-acid battery (or a car battery) can be used if the display must be independent of the mains.

## Operation

When the power is switched on, the running text that was last entered is automatically displayed. If no text has yet been programmed, 'ELEKTOR' appears on the display. Connect the transmitter to a PC keyboard and then apply power to it. If the transmitter is working properly, the Scroll LED should be illuminated on the keyboard. Press the F2 key to clear the display and cause a cursor to appear. You can now enter the desired text. Press the Shift key briefly to switch between lower-case and upper-case characters. This will cause the appearance of the cursor to change. Incorrectly entered characters can be deleted using the Backspace key, up to the first character entered. It is not possible to erase previously entered characters; if this is necessary, press the Esc key to end the current entry session and then press F2 to start anew. Press Enter when you have finished entering the text. After this, the running text display will start automatically.

After each text display cycle, the time of day is automatically displayed for about 15 seconds. The time can be set using the F1 key. If you do not want this alternating display mode, you can use the F3 and F4 keys to select a different mode. The meanings of the keyboard keys are explained in the 'Keyboard Input' box. Since the microcontroller does not have a real-time clock with a separate 32-kHz crystal, the clock keeps relatively poor time, due to the high clock frequency and the tolerance of the crystal. A small trimmer capacitor in place of C1 can help to improve the situation.

(990090-1)

Design editing: K. Walraven

## Keyboard input

Esc:	Cancel input
F1:	Enter the time of day
F2:	Enter the running text
F3:	Running text only (on/off)
F4:	Time of day only (on/off)
Shift:	Switch between upper and lower case
Return:	End the entry session and start the running text display
Delete:	Erase the character in the input window