

COMPAL CONFIDENTIAL
 MODEL NAME : ATR11 LA-1391
 REV: 1.0

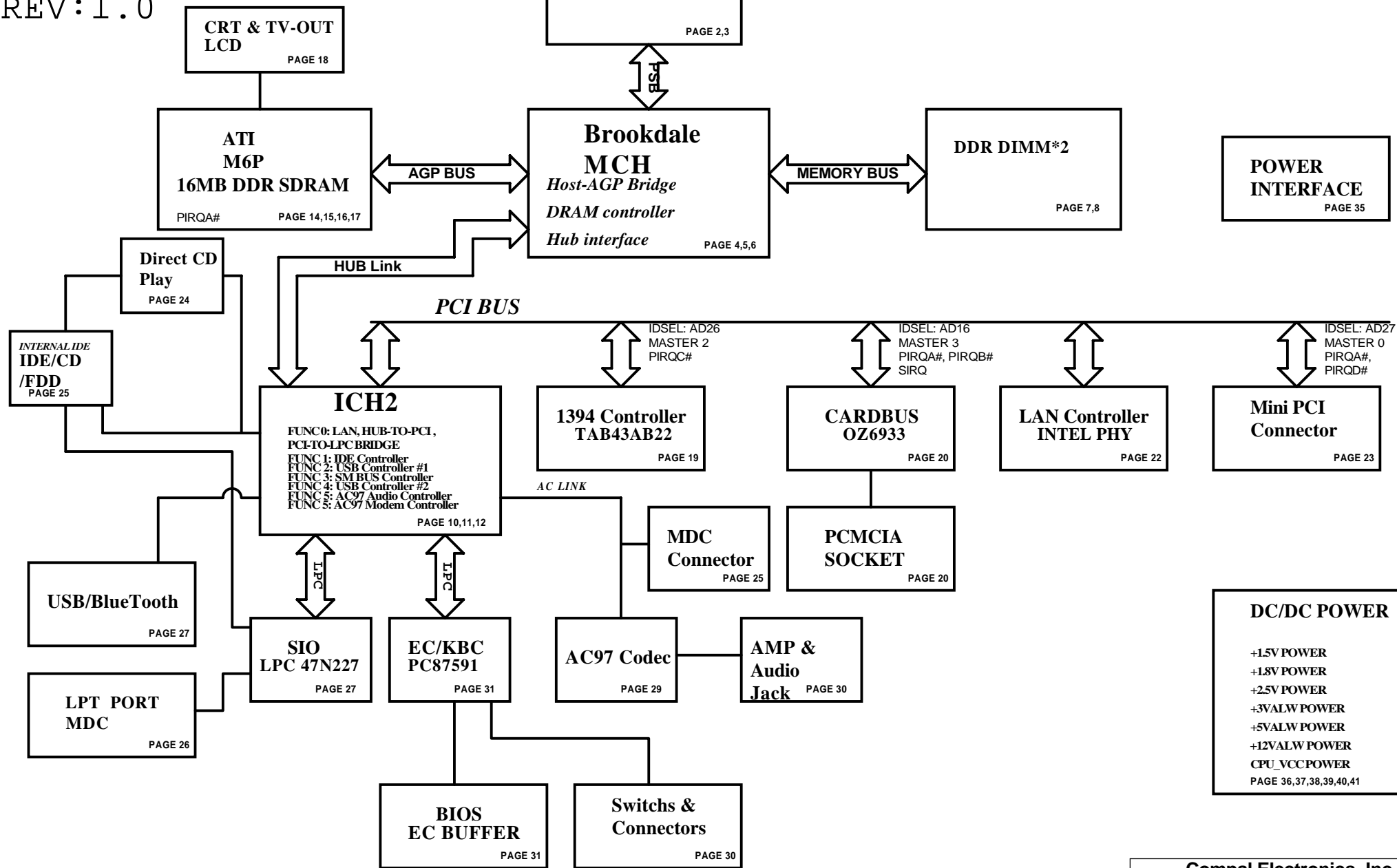

PROPRIETARY NOTE THIS SHEET OF ENGINEERING DRAWING IS THE PROPRIETARY PROPERTY OF COMPAL ELECTRONICS, INC. AND CONTAINS CONFIDENTIAL AND TRADE SECRET INFORMATION. THIS SHEET MAY NOT BE TRANSFERRED FROM THE CUSTODY OF THE COMPETENT DIVISION OF R&D DEPARTMENT EXCEPT AS AUTHORIZED BY COMPAL ELECTRONICS, INC. NEITHER THIS SHEET NOR THE INFORMATION IT CONTAINS MAY BE USED BY OR DISCLOSED TO ANY THIRD PARTY WITHOUT PRIOR WRITTEN CONSENT OF COMPAL ELECTRONICS, INC.

Compal Electronics, Inc.		
Title	SCHEMATIC, M/B LA-1391	
Size	Document Number	Rev
B	401211	1B
Date:	-P 期二、十一月 26, 2002	Sheet 1 of 44

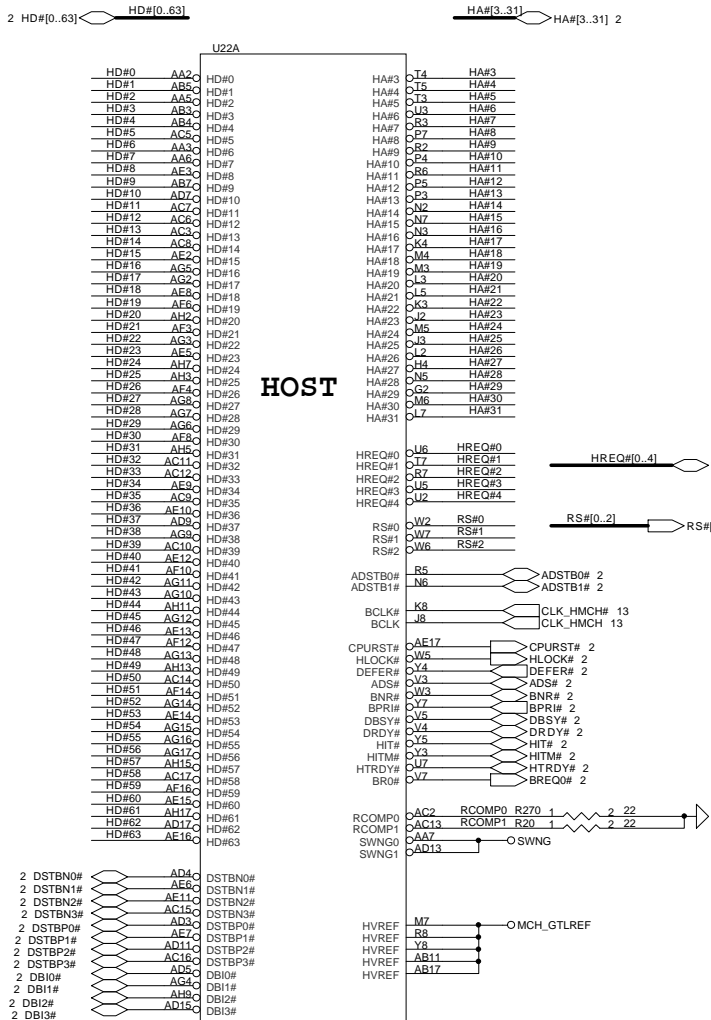

HOST

AGP

HUB

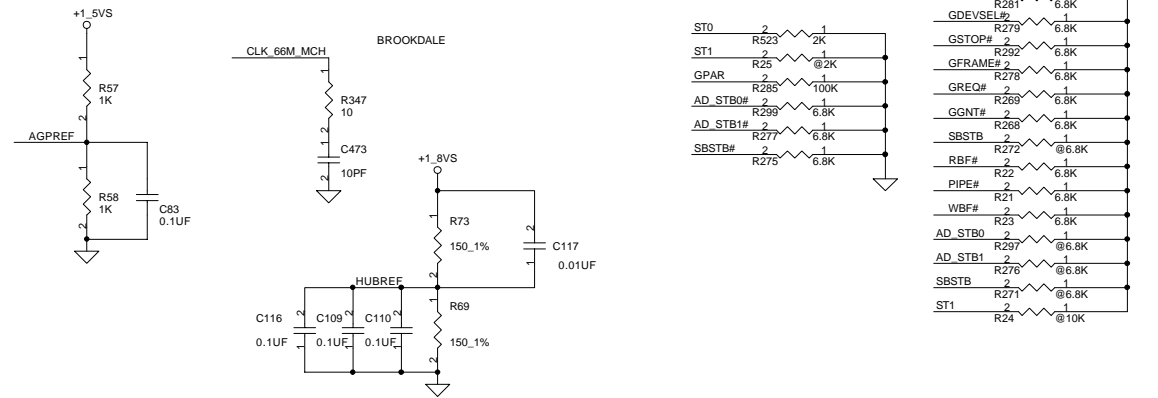
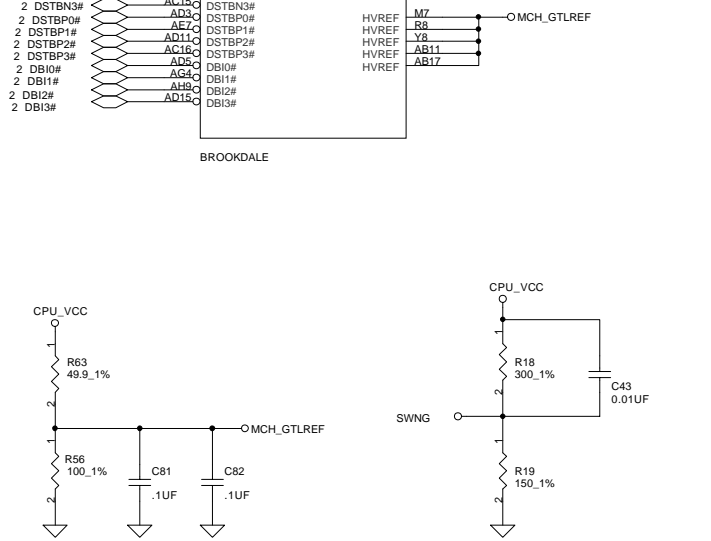

THIS SHEET OF ENGINEERING DRAWING IS THE PROPRIETARY PROPERTY OF COMPAL ELECTRONICS, INC. AND CONTAINS CONFIDENTIAL AND TRADE SECRET INFORMATION. THIS SHEET MAY NOT BE TRANSFERRED FROM THE CUSTODY OF THE COMPETENT DIVISION OF R&D DEPARTMENT EXCEPT AS AUTHORIZED BY COMPAL ELECTRONICS, INC. NEITHER THIS SHEET NOR THE INFORMATION IT CONTAINS MAY BE USED BY OR DISCLOSED TO ANY THIRD PARTY WITHOUT PRIOR WRITTEN CONSENT OF COMPAL ELECTRONICS, INC.

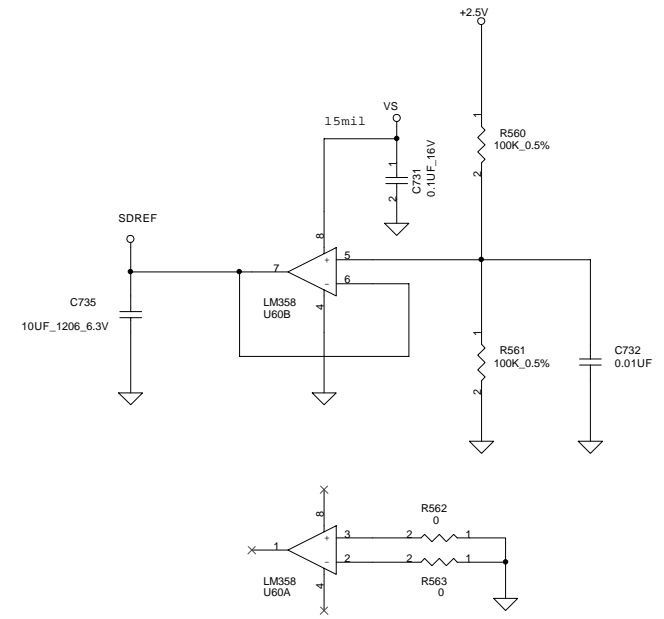
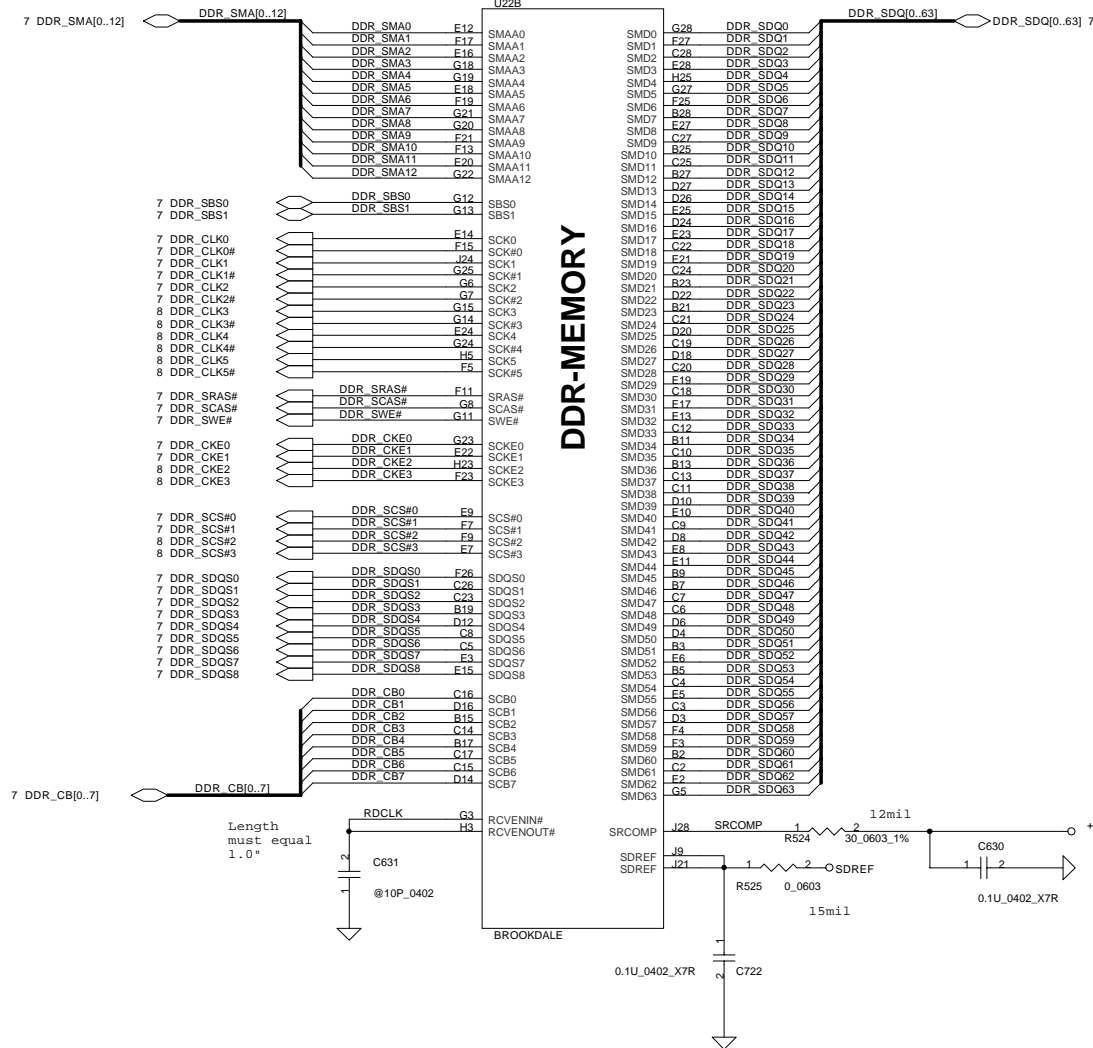

Compal Electronics, Inc.		
Title	SCHEMATIC, M/B LA-1391	
Size B	Document Number	Rev 1B
	401211	
Date:	星期二, 十一月 26, 2002	Sheet 5 of 44

THIS SHEET OF ENGINEERING DRAWING IS THE PROPRIETARY PROPERTY OF COMPAL ELECTRONICS, INC. AND CONTAINS CONFIDENTIAL AND TRADE SECRET INFORMATION. THIS SHEET MAY NOT BE TRANSFERRED FROM THE CUSTODY OF THE COMPETENT DIVISION OF R&D DEPARTMENT EXCEPT AS AUTHORIZED BY COMPAL ELECTRONICS, INC. NEITHER THIS SHEET NOR THE INFORMATION IT CONTAINS MAY BE USED BY OR DISCLOSED TO ANY THIRD PARTY WITHOUT PRIOR WRITTEN CONSENT OF COMPAL ELECTRONICS, INC.

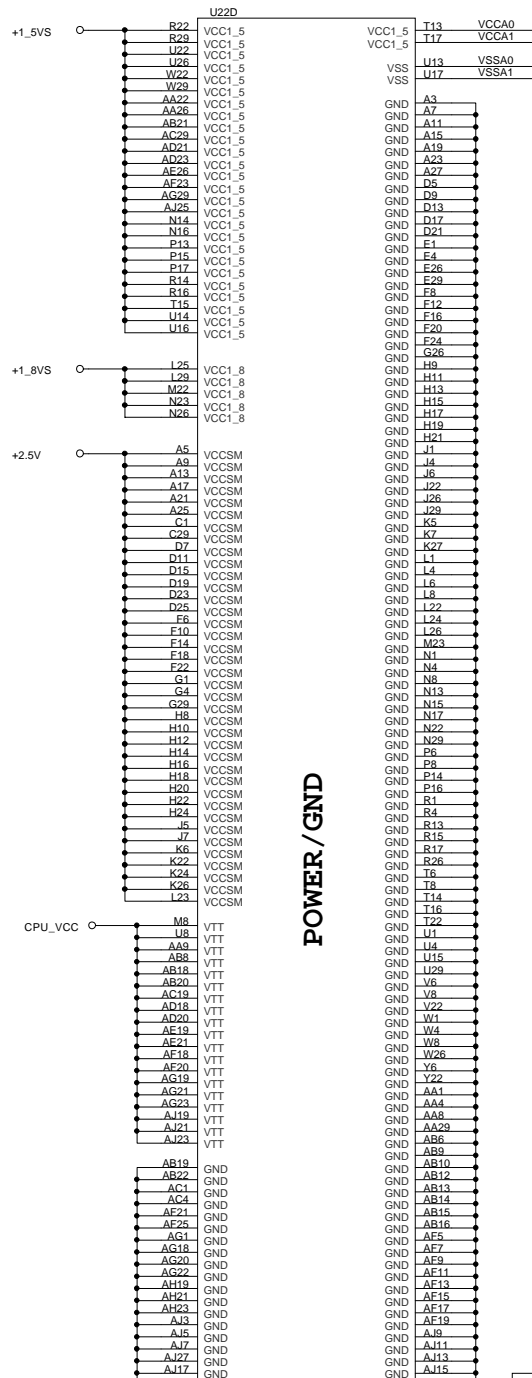

POWER / GND

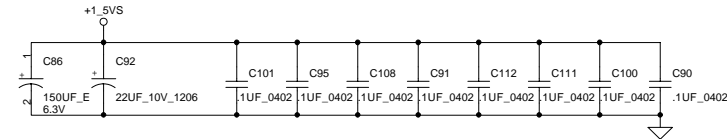
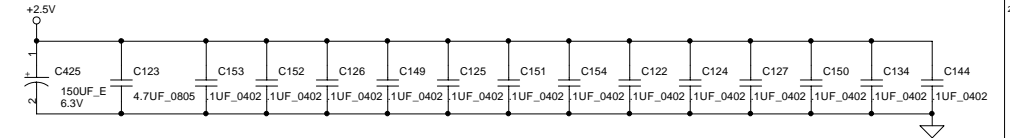
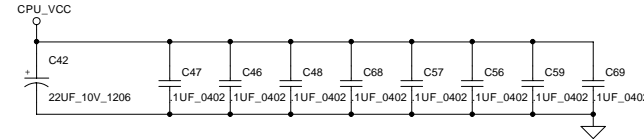
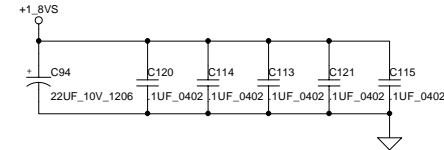
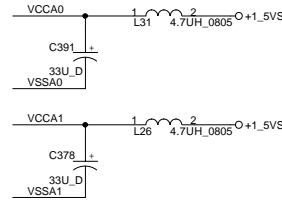

THIS SHEET OF ENGINEERING DRAWING IS THE PROPRIETARY PROPERTY OF COMPAL ELECTRONICS, INC. AND CONTAINS CONFIDENTIAL AND TRADE SECRET INFORMATION. THIS SHEET MAY NOT BE TRANSFERRED FROM THE CUSTODY OF THE COMPETENT DIVISION OF R&D DEPARTMENT EXCEPT AS AUTHORIZED BY COMPAL ELECTRONICS, INC. NEITHER THIS SHEET NOR THE INFORMATION IT CONTAINS MAY BE USED BY OR DISCLOSED TO ANY THIRD PARTY WITHOUT PRIOR WRITTEN CONSENT OF COMPAL ELECTRONICS, INC.

Compal Electronics, Inc.		
Title	SCHEMATIC, M/B LA-1391	
Size	Document Number	Rev
B	401211	B
Date:	星期二, 十一月 26, 2002	Sheet 6 of 44

Layout note

Place these resistor closely DIMMO, all trace length<750mil

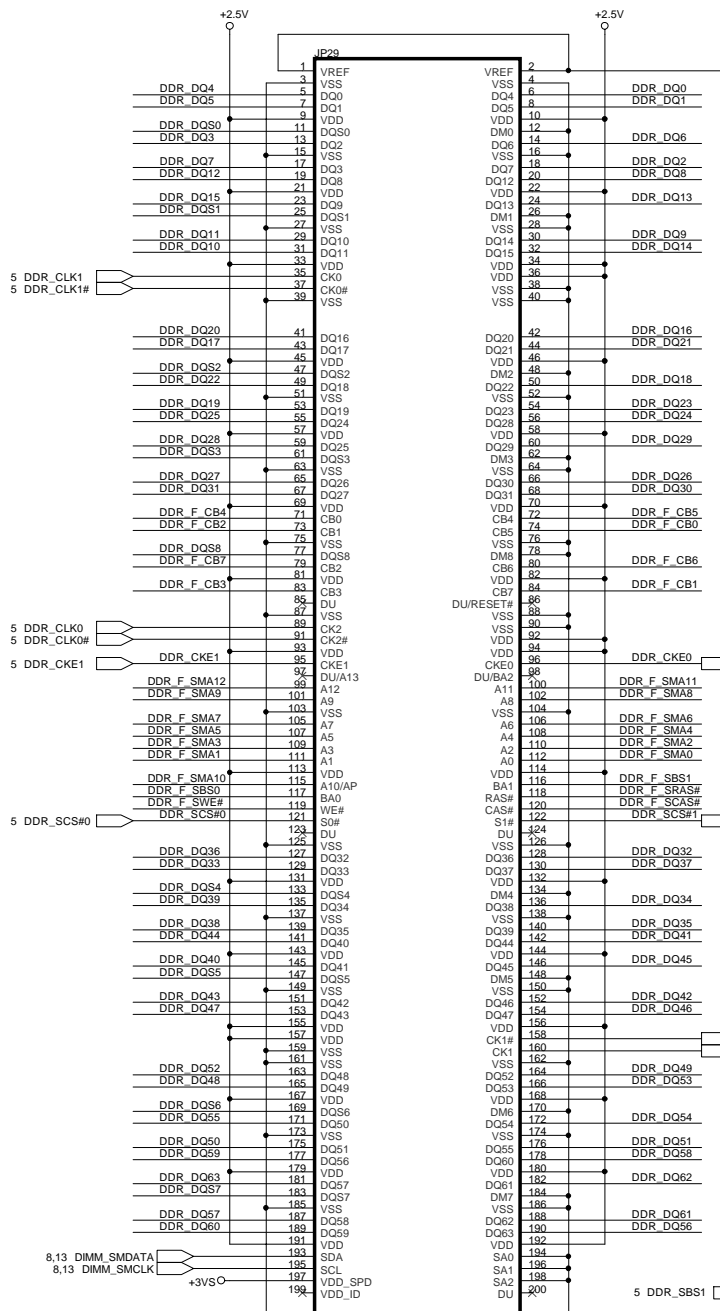
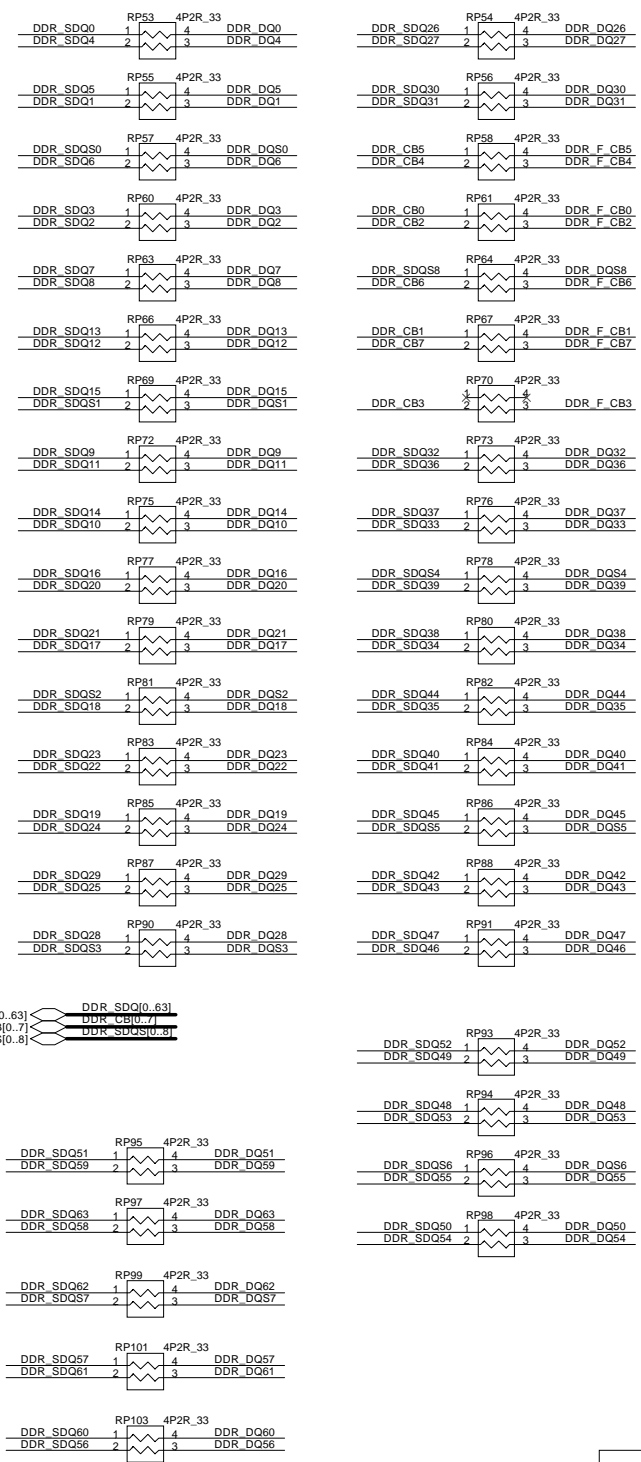

DIMMO (STD)
 Top side

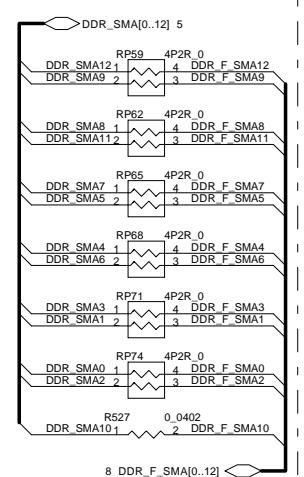

Layout note
 Place these resistor closely DIMMO, all trace length<=750mil

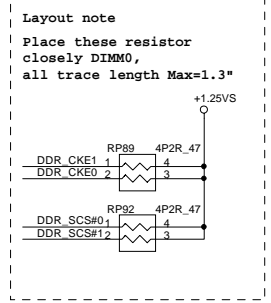

Layout note
 Place these resistor closely DIMMO, all trace length<=750mil

Compal Electronics, Inc.

SCHEMATIC, M/B LA-1391

Title	SCHEMATIC, M/B LA-1391		Rev	1B
Size	Document Number	401211		
Date	日期	21- 726, 2002	Sheet	7 of 44

THIS SHEET OF ENGINEERING DRAWING IS THE PROPRIETARY PROPERTY OF COMPAL ELECTRONICS, INC. AND CONTAINS CONFIDENTIAL AND TRADE SECRET INFORMATION. THIS SHEET MAY NOT BE TRANSFERRED FROM THE CUSTODY OF THE COMPETENT DIVISION OF R&D DEPARTMENT EXCEPT AS AUTHORIZED BY COMPAL ELECTRONICS, INC. NEITHER THIS SHEET NOR THE INFORMATION IT CONTAINS MAY BE USED BY OR DISCLOSED TO ANY THIRD PARTY WITHOUT PRIOR WRITTEN CONSENT OF COMPAL ELECTRONICS, INC.

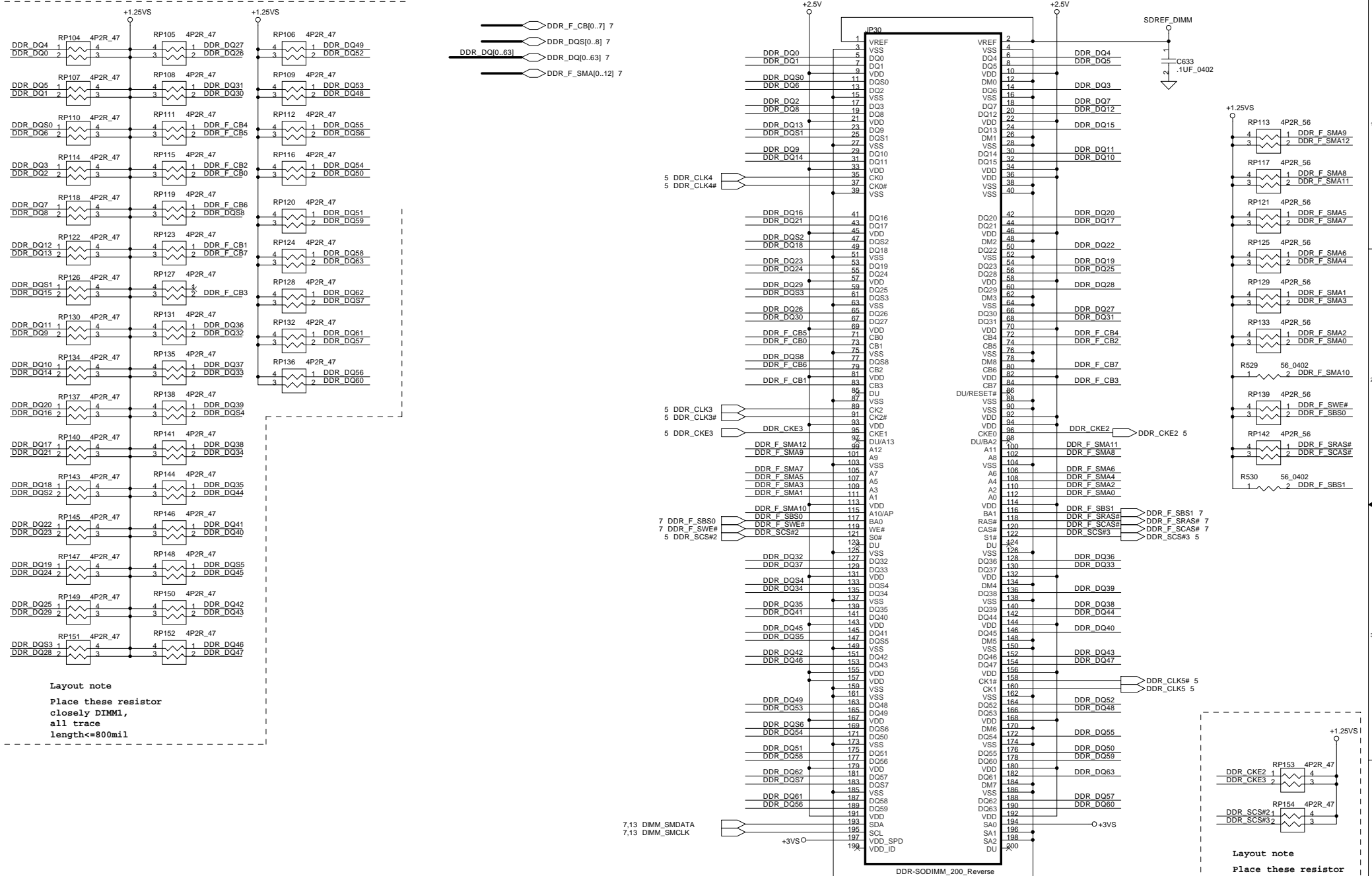

Layout note
Place these resistor closely DIMM1, all trace length<=800mil

Layout note
Place these resistor closely DIMM1, all trace length Max=1.3"

DIMM1 (REV)
Bottom side

Title			Compal Electronics, Inc.	
Size			SCHEMATIC, M/B LA-1391	
Date			401211	
Date			Rev 1B	

PROPRIETARY INFORMATION. THIS SHEET MAY NOT BE TRANSFERRED FROM THE CUSTODY OF THE COMPETENT DIVISION OF R&D DEPARTMENT EXCEPT AS AUTHORIZED BY COMPAL ELECTRONICS, INC. NEITHER THIS SHEET NOR THE INFORMATION IT CONTAINS MAY BE USED BY OR DISCLOSED TO ANY THIRD PARTY WITHOUT PRIOR WRITTEN CONSENT OF COMPAL ELECTRONICS, INC.

Layout note :
Distribute as close as possible to DDR-SODIMM.

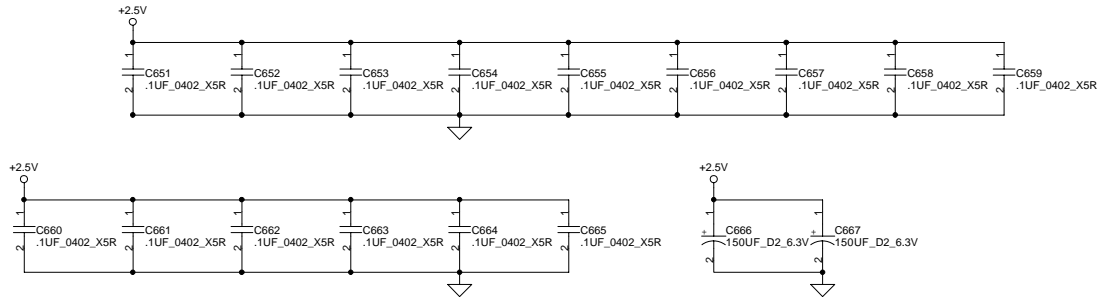

Layout note :
Place one cap close to every 2 pull up resistors termination to +1.25V

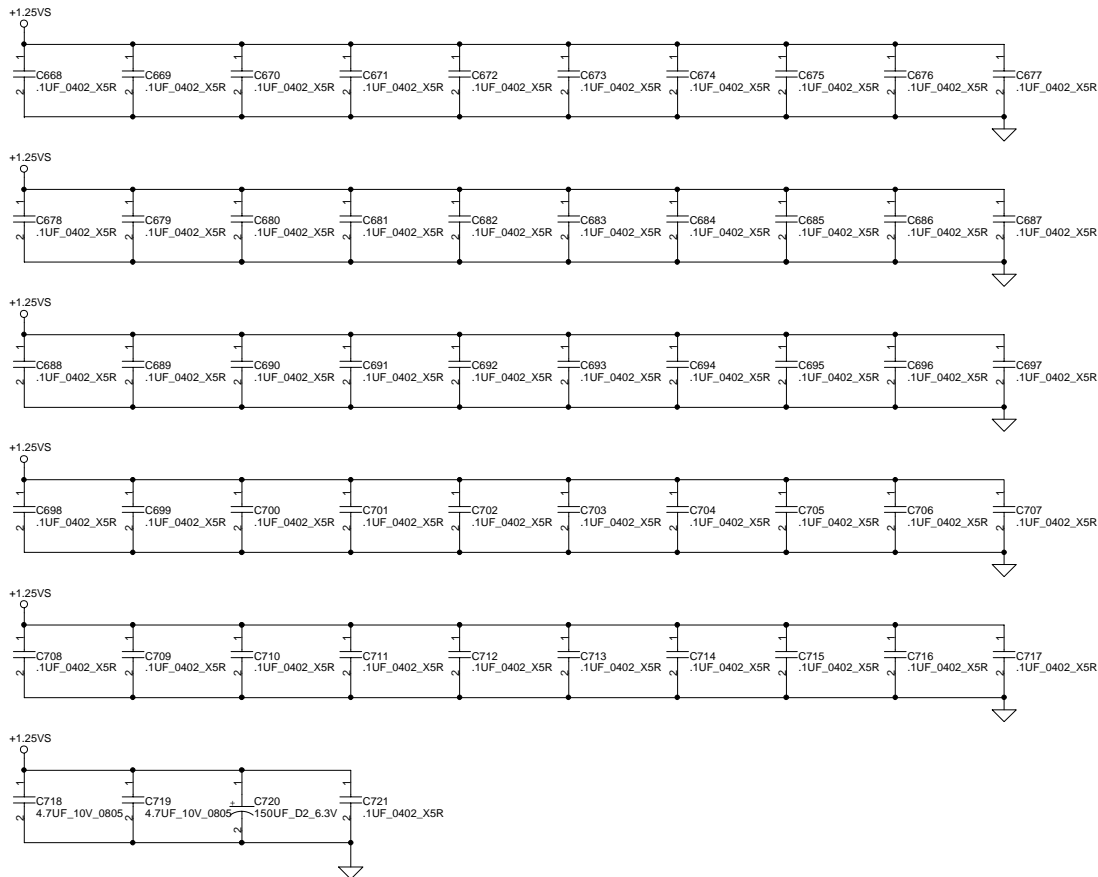

THIS SHEET OF ENGINEERING DRAWING IS THE PROPRIETARY PROPERTY OF COMPAL ELECTRONICS, INC. AND CONTAINS CONFIDENTIAL AND PROPRIETARY NOTE TRADE SECRET INFORMATION. THIS SHEET MAY NOT BE TRANSFERRED FROM THE CUSTODY OF THE COMPETENT DIVISION OF R&D DEPARTMENT EXCEPT AS AUTHORIZED BY COMPAL ELECTRONICS, INC. NEITHER THIS SHEET NOR THE INFORMATION IT CONTAINS MAY BE USED BY OR DISCLOSED TO ANY THIRD PARTY WITHOUT PRIOR WRITTEN CONSENT OF COMPAL ELECTRONICS, INC.

Compal Electronics, Inc.		
Title		
SCHEMATIC, M/B LA-1391		
Size	Document Number	Rev
	401211	1B
Date:	星期二, 十一月 22, 2002	Sheet 9 of 44

ICH-2

(FW82801BA)

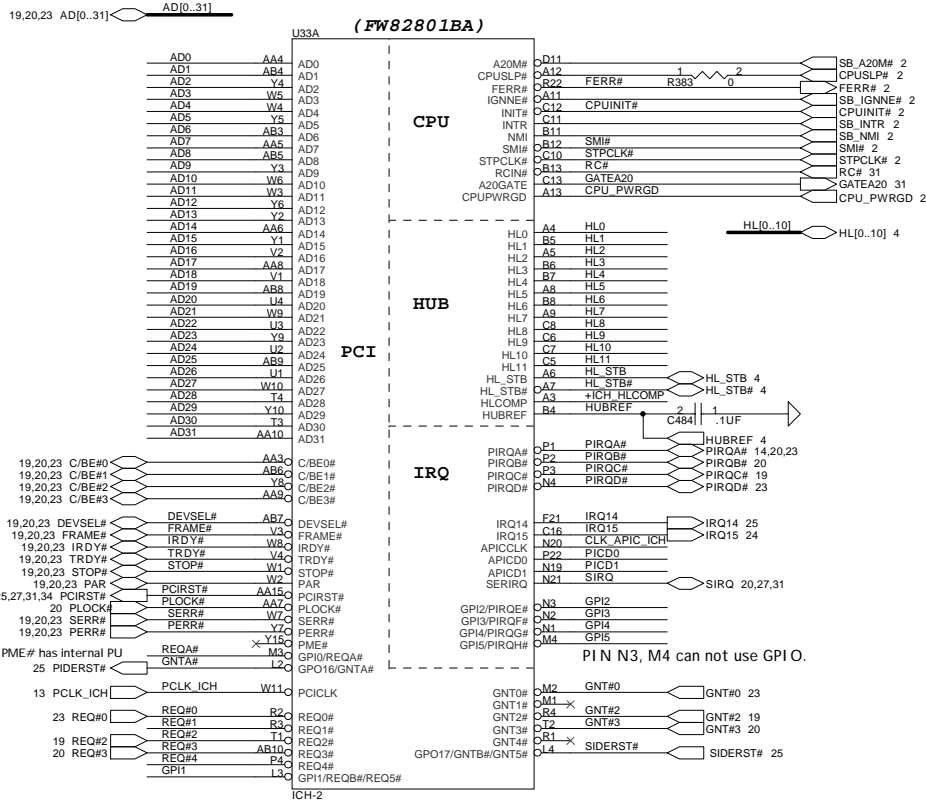

PCI Pullups

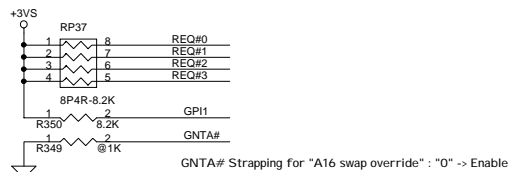
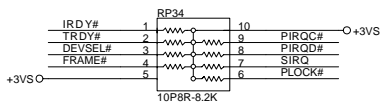
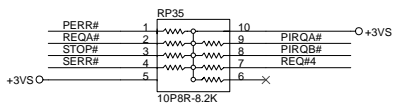

REQ#	Assignment
REQ#0	WLAN
REQ#1	NC
REQ#2	1394
REQ#3	PCMCIA CONTROLLER
REQ#4	NC

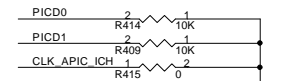
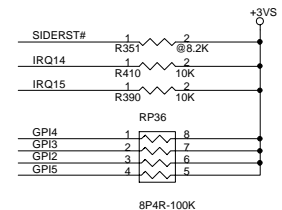
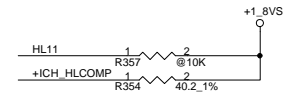
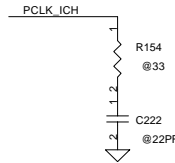

Compal Electronics, Inc.

SCHEMATIC, M/B LA-1391

Size B	Document Number 401211	Rev 1B
Date: 星期二, 十一月 26, 2002	Sheet 10 of 44	

THIS SHEET OF ENGINEERING DRAWING IS THE PROPRIETARY PROPERTY OF COMPAL ELECTRONICS, INC. AND CONTAINS CONFIDENTIAL AND TRADE SECRET INFORMATION. THIS SHEET MAY NOT BE TRANSFERRED FROM THE CUSTODY OF THE COMPETENT DIVISION OF R&D DEPARTMENT EXCEPT AS AUTHORIZED BY COMPAL ELECTRONICS, INC. NEITHER THIS SHEET NOR THE INFORMATION IT CONTAINS MAY BE USED BY OR DISCLOSED TO ANY THIRD PARTY WITHOUT PRIOR WRITTEN CONSENT OF COMPAL ELECTRONICS, INC.

ICH2-B(IDE,LPC,GPIO)

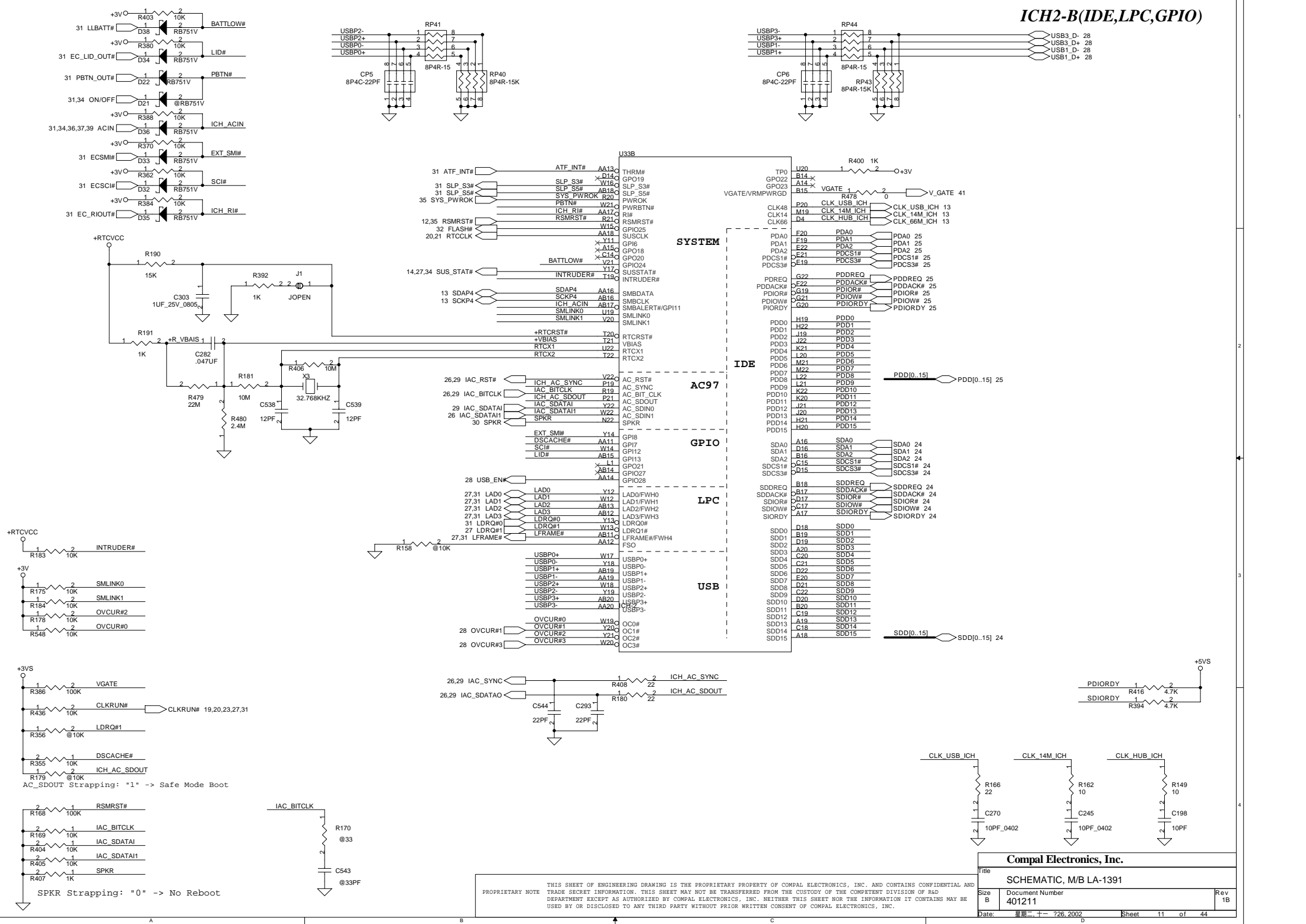

Compal Electronics, Inc.		
Title SCHEMATIC, M/B LA-1391		
Size B	Document Number 401211	Rev 1B
Date: 星期二, 十一月 26, 2002	Sheet	11 of 44

PROPRIETARY NOTE: THIS SHEET OF ENGINEERING DRAWING IS THE PROPRIETARY PROPERTY OF COMPAL ELECTRONICS, INC. AND CONTAINS CONFIDENTIAL AND TRADE SECRET INFORMATION. THIS SHEET MAY NOT BE TRANSFERRED FROM THE CUSTODY OF THE COMPETENT DIVISION OF R&D DEPARTMENT EXCEPT AS AUTHORIZED BY COMPAL ELECTRONICS, INC. NEITHER THIS SHEET NOR THE INFORMATION IT CONTAINS MAY BE USED BY OR DISCLOSED TO ANY THIRD PARTY WITHOUT PRIOR WRITTEN CONSENT OF COMPAL ELECTRONICS, INC.

SEL2	SEL1	SEL0	CPUCLK0[0..2]	CPUCLK1[0..2]
0	0	0	56.57	56.57
0	0	1	100.00	100.00
0	1	0	200.00	200.00
0	1	1	133.33	133.33

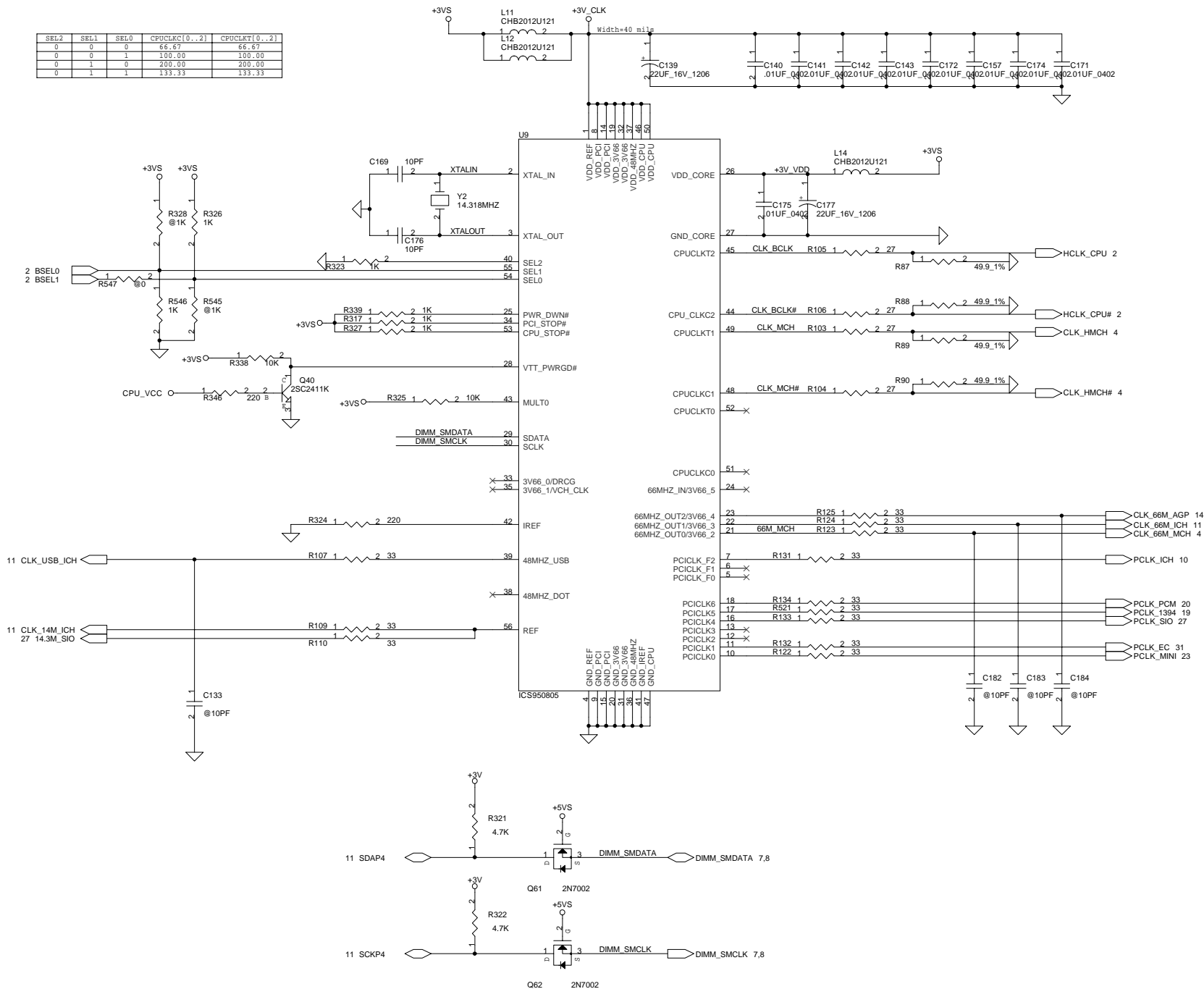

THIS SHEET OF ENGINEERING DRAWING IS THE PROPRIETARY PROPERTY OF COMPAL ELECTRONICS, INC. AND CONTAINS CONFIDENTIAL AND TRADE SECRET INFORMATION. THIS SHEET MAY NOT BE TRANSFERRED FROM THE CUSTODY OF THE COMPETENT DIVISION OF R&D DEPARTMENT EXCEPT AS AUTHORIZED BY COMPAL ELECTRONICS, INC. NEITHER THIS SHEET NOR THE INFORMATION IT CONTAINS MAY BE USED BY OR DISCLOSED TO ANY THIRD PARTY WITHOUT PRIOR WRITTEN CONSENT OF COMPAL ELECTRONICS, INC.

Compal Electronics, Inc.		
Title		
SCHEMATIC, M/B LA-1391		
Size	Document Number	Rev
B	401211	1B
Date:	星期二, 十一月 26, 2002	Sheet 13 of 44

HOST INTERFACE

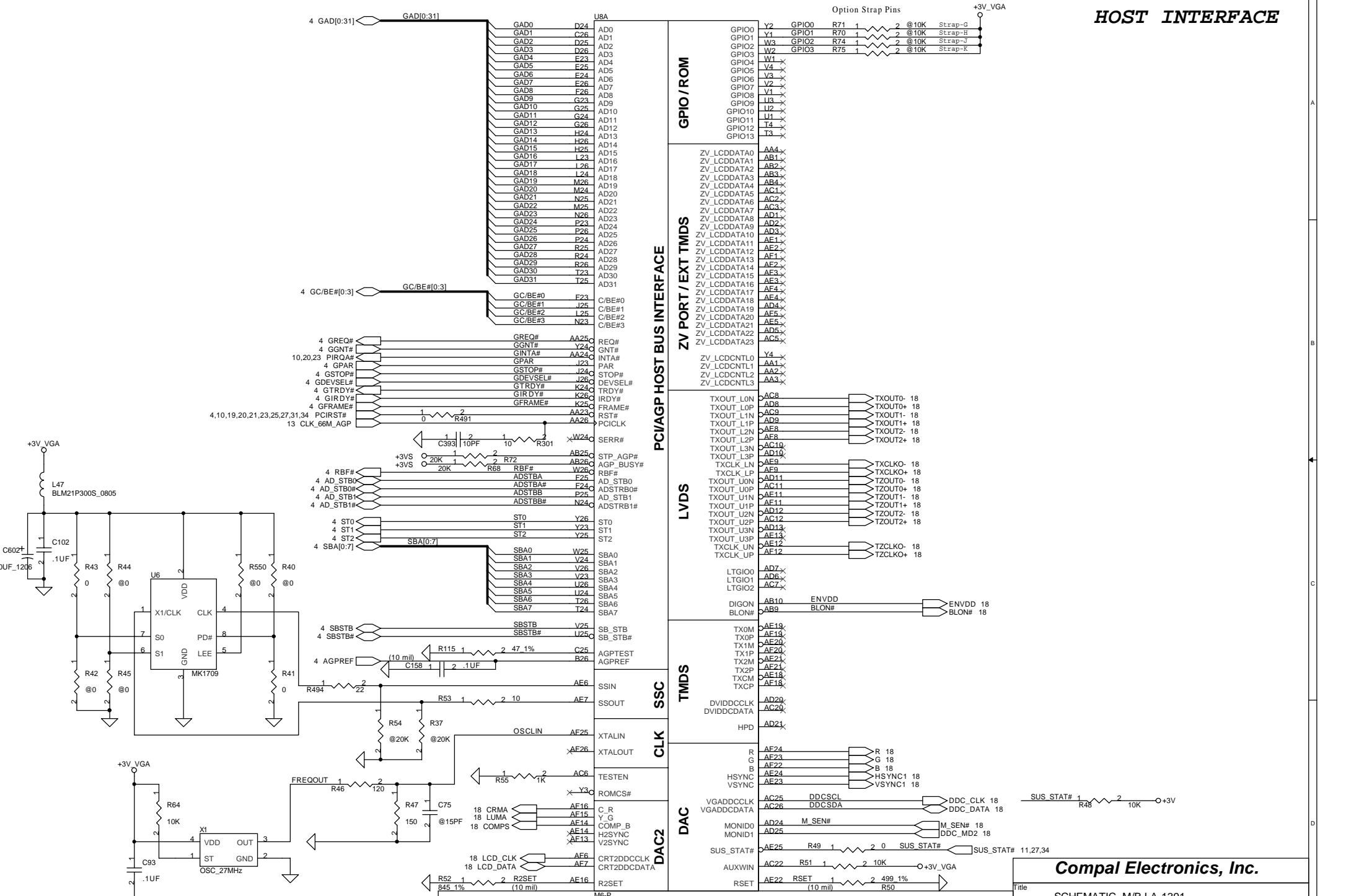

Compal Electronics, Inc.

Title: SCHEMATIC, M/B LA-1391

Size	Document Number	Rev
Custom	401211	18

Date: 星期二, 十一月 26, 2002 Sheet 14 of 44

THIS SHEET OF ENGINEERING DRAWING IS THE PROPRIETARY PROPERTY OF COMPAL ELECTRONICS, INC. AND CONTAINS CONFIDENTIAL AND TRADE SECRET INFORMATION. THIS SHEET MAY NOT BE TRANSFERRED FROM THE CUSTODY OF THE COMPETENT DIVISION OF R&D DEPARTMENT EXCEPT AS AUTHORIZED BY COMPAL ELECTRONICS, INC. NEITHER THIS SHEET NOR THE INFORMATION IT CONTAINS MAY BE USED BY OR DISCLOSED TO ANY THIRD PARTY WITHOUT PRIOR WRITTEN CONSENT OF COMPAL ELECTRONICS, INC.

MEMORY INTERFACE

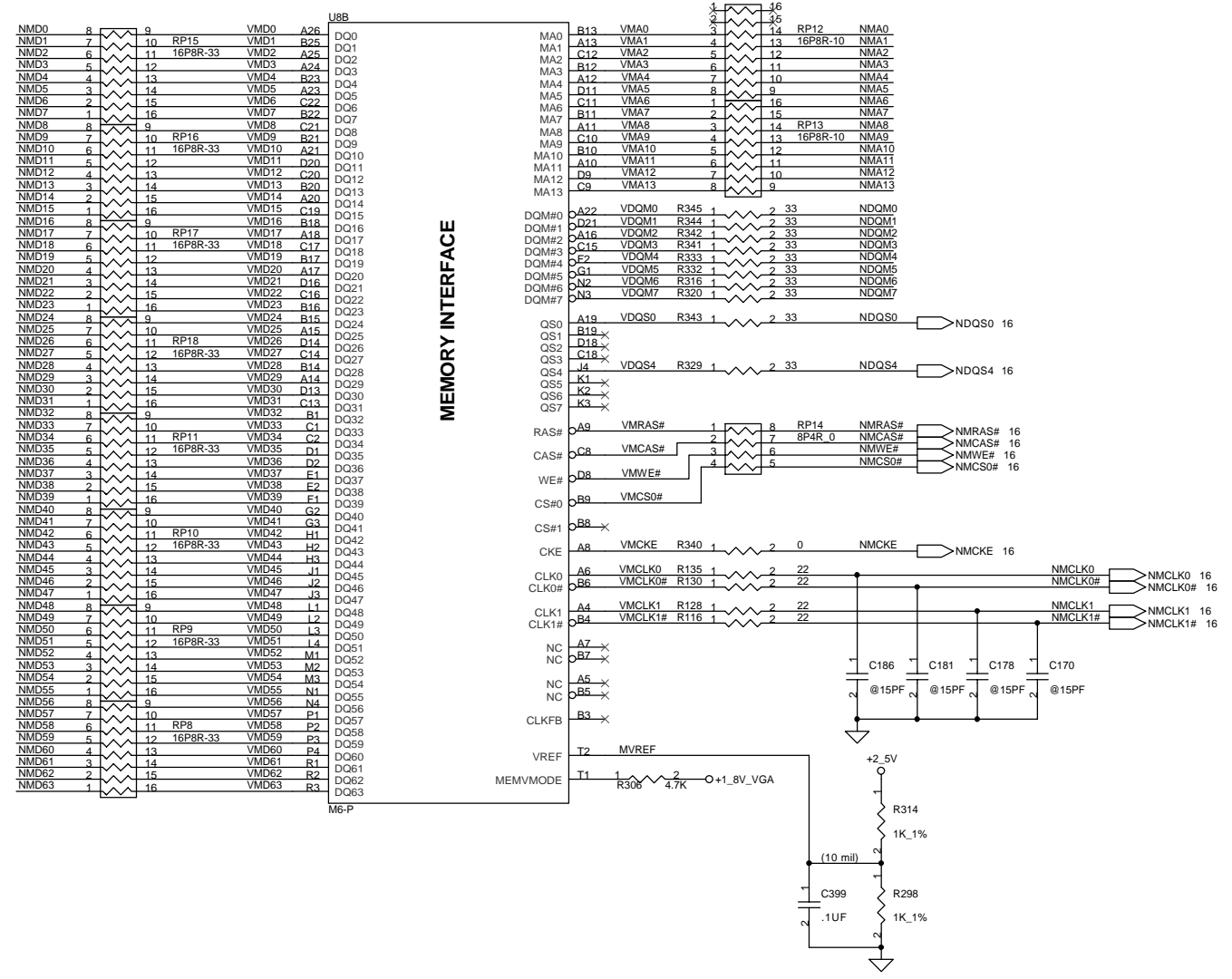
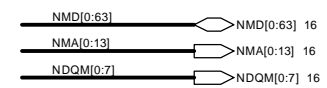

PROPRIETARY NOTE THIS SHEET OF ENGINEERING DRAWING IS THE PROPRIETARY PROPERTY OF COMPAL ELECTRONICS, INC. AND CONTAINS CONFIDENTIAL AND TRADE SECRET INFORMATION. THIS SHEET MAY NOT BE TRANSFERRED FROM THE CUSTODY OF THE COMPETENT DIVISION OF R&D DEPARTMENT EXCEPT AS AUTHORIZED BY COMPAL ELECTRONICS, INC. NEITHER THIS SHEET NOR THE INFORMATION IT CONTAINS MAY BE USED BY OR DISCLOSED TO ANY THIRD PARTY WITHOUT PRIOR WRITTEN CONSENT OF COMPAL ELECTRONICS, INC.

Compal Electronics, Inc.

Title: SCHEMATIC, M/B LA-1391

Size	Document Number	Rev
Custom	401211	1B
Date:	星期二, 十一月 26, 2002	Sheet 15 of 44

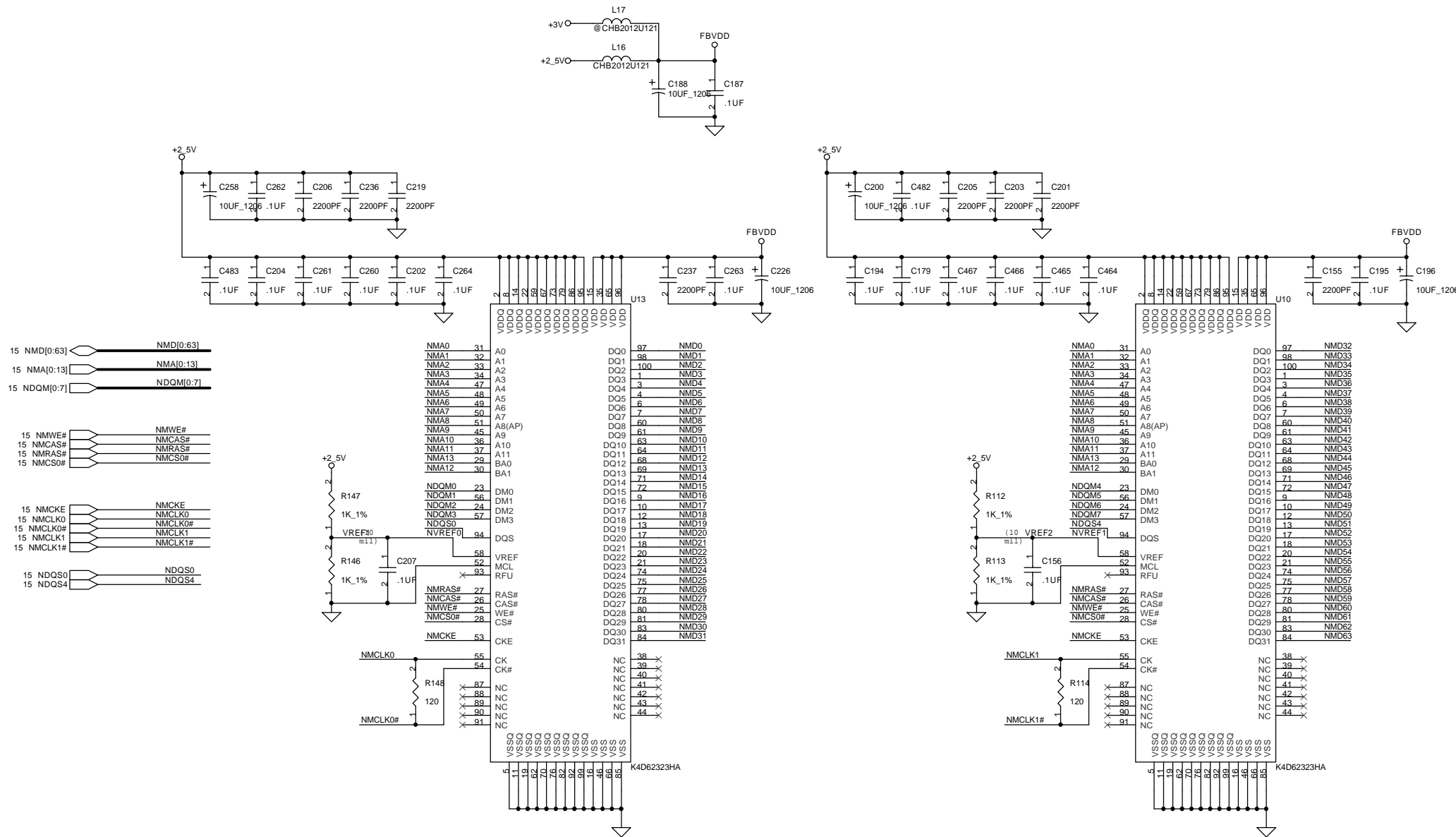

- 15 NMD[0:63] → NMD[0:63]
- 15 NMA[0:13] → NMA[0:13]
- 15 NDQM[0:7] → NDQM[0:7]
- 15 NMWE# → NMWE#
- 15 NMCAS# → NMCAS#
- 15 NMRAS# → NMRAS#
- 15 NMCS0# → NMCS0#
- 15 NMCKE → NMCKE
- 15 NMCKL0 → NMCKL0
- 15 NMCKL0# → NMCKL0#
- 15 NMCKL1 → NMCKL1
- 15 NMCKL1# → NMCKL1#
- 15 NDQS0 → NDQS0
- 15 NDQS4 → NDQS4

- 15 NMCKE → NMCKE
- 15 NMCKL0 → NMCKL0
- 15 NMCKL0# → NMCKL0#
- 15 NMCKL1 → NMCKL1
- 15 NMCKL1# → NMCKL1#
- 15 NDQS0 → NDQS0
- 15 NDQS4 → NDQS4

Compal Electronics, Inc.

Title: SCHEMATIC, M/B LA-1391

Size	Document Number	Rev
Custom	401211	18

Date: 星期二, 十一月 26, 2002 Sheet 16 of 44

THIS SHEET OF ENGINEERING DRAWING IS THE PROPRIETARY PROPERTY OF COMPAL ELECTRONICS, INC. AND CONTAINS CONFIDENTIAL AND TRADE SECRET INFORMATION. THIS SHEET MAY NOT BE TRANSFERRED FROM THE CUSTODY OF THE COMPETENT DIVISION OF R&D DEPARTMENT EXCEPT AS AUTHORIZED BY COMPAL ELECTRONICS, INC. NEITHER THIS SHEET NOR THE INFORMATION IT CONTAINS MAY BE USED BY OR DISCLOSED TO ANY THIRD PARTY WITHOUT PRIOR WRITTEN CONSENT OF COMPAL ELECTRONICS, INC.

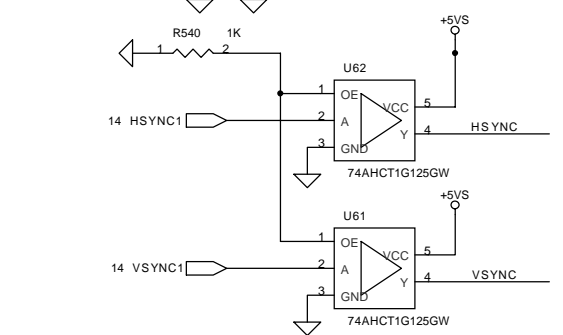
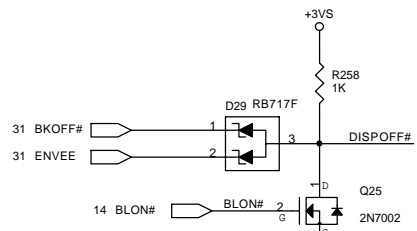
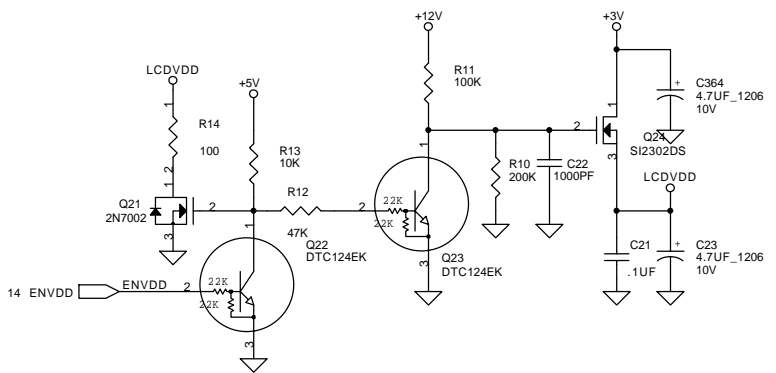
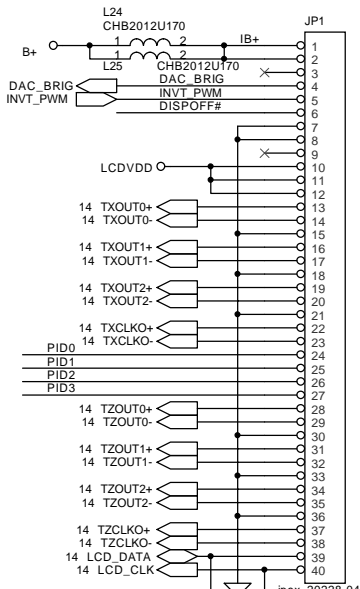
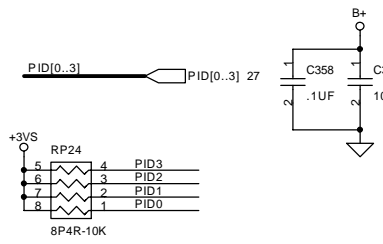
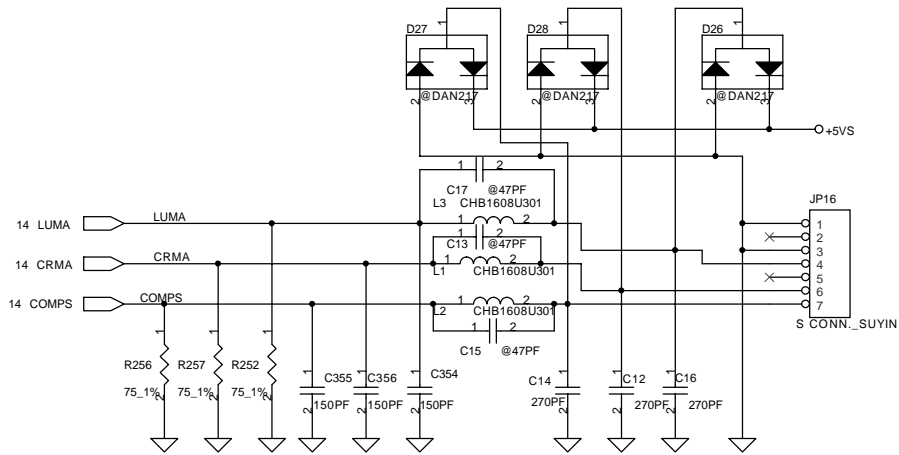

CRT Connector

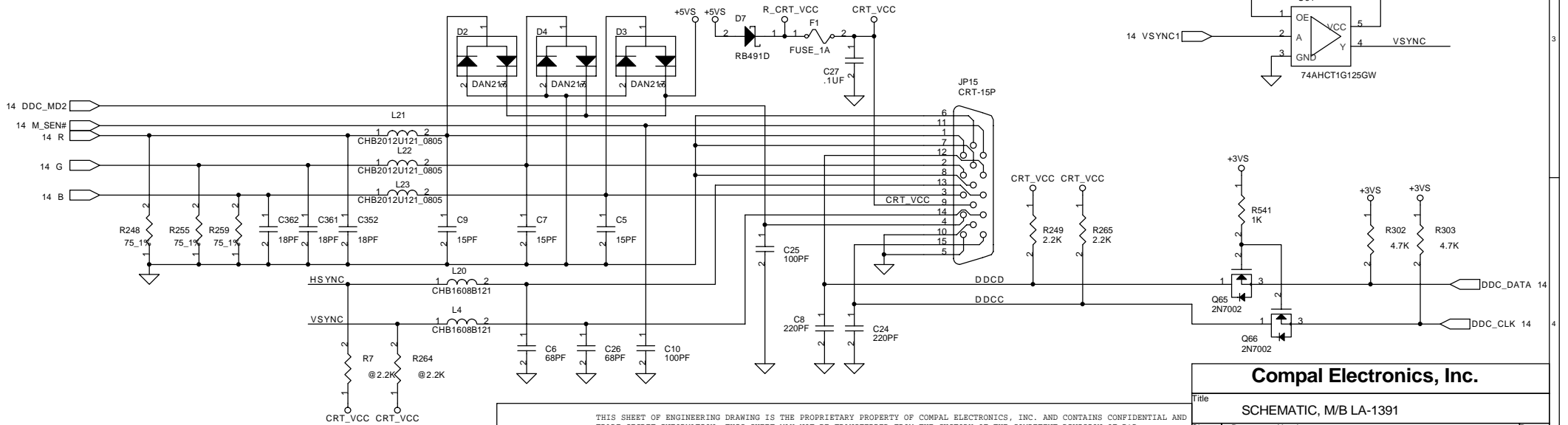

THIS SHEET OF ENGINEERING DRAWING IS THE PROPRIETARY PROPERTY OF COMPAL ELECTRONICS, INC. AND CONTAINS CONFIDENTIAL AND TRADE SECRET INFORMATION. THIS SHEET MAY NOT BE TRANSFERRED FROM THE CUSTODY OF THE COMPETENT DIVISION OF R&D DEPARTMENT EXCEPT AS AUTHORIZED BY COMPAL ELECTRONICS, INC. NEITHER THIS SHEET NOR THE INFORMATION IT CONTAINS MAY BE USED BY OR DISCLOSED TO ANY THIRD PARTY WITHOUT PRIOR WRITTEN CONSENT OF COMPAL ELECTRONICS, INC.

Compal Electronics, Inc.		
Title SCHEMATIC, M/B LA-1391		
Size B	Document Number 401211	Rev 1B
Date 日期: 十一月 26, 2002	Sheet 18	of 44

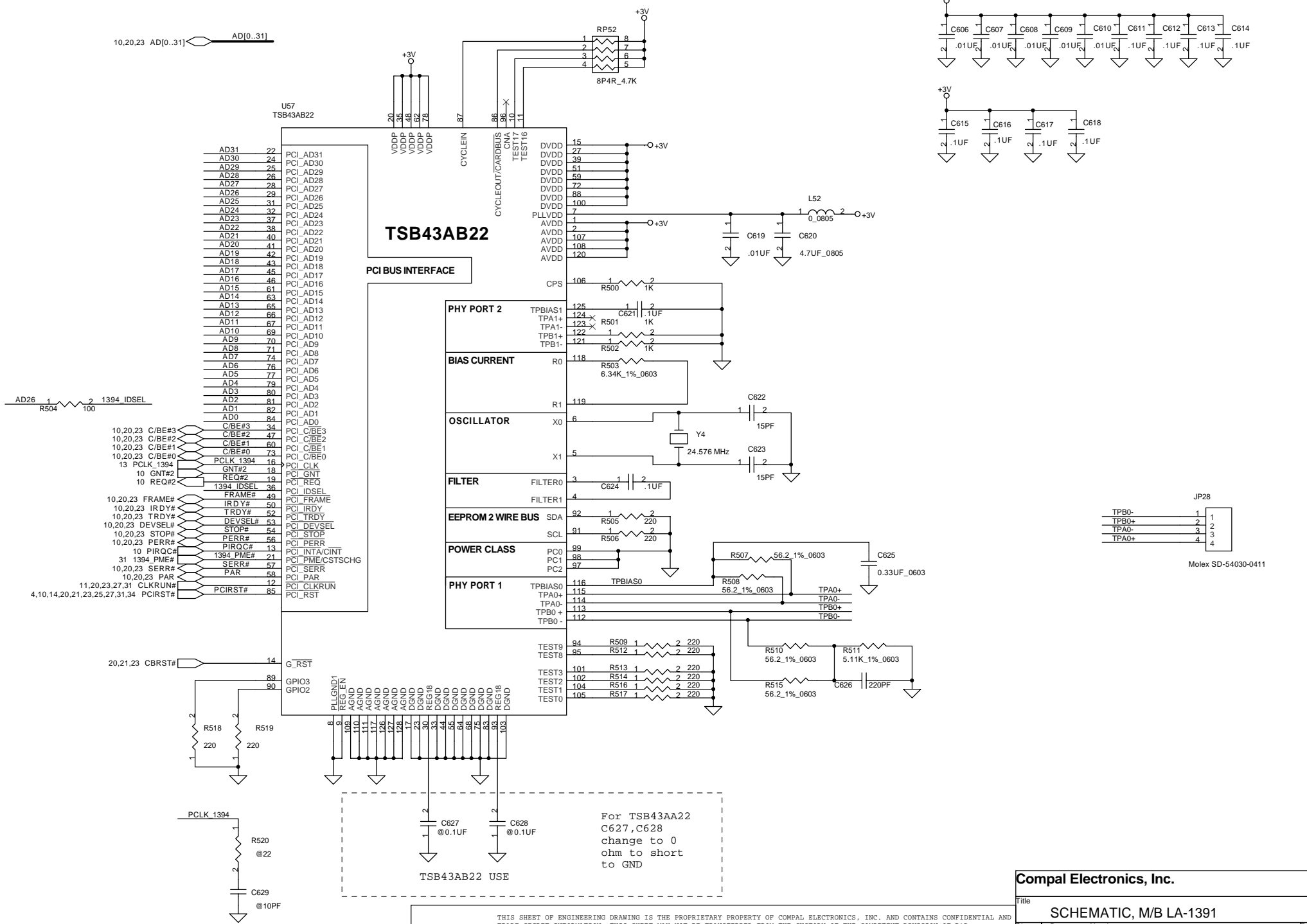

10,20,23 AD[0..31] AD[0..31]

U57
TSB43AB22

TSB43AB22

PCI BUS INTERFACE

PHY PORT 2

BIAS CURRENT

OSCILLATOR

FILTER

EEPROM 2 WIRE BUS

POWER CLASS

PHY PORT 1

- AD31 22 PCI_AD31
- AD30 24 PCI_AD30
- AD29 25 PCI_AD29
- AD28 26 PCI_AD28
- AD27 28 PCI_AD27
- AD26 29 PCI_AD26
- AD25 31 PCI_AD25
- AD24 32 PCI_AD24
- AD23 37 PCI_AD23
- AD22 38 PCI_AD22
- AD21 40 PCI_AD21
- AD20 41 PCI_AD20
- AD19 42 PCI_AD19
- AD18 43 PCI_AD18
- AD17 46 PCI_AD17
- AD16 48 PCI_AD16
- AD15 61 PCI_AD15
- AD14 63 PCI_AD14
- AD13 65 PCI_AD13
- AD12 66 PCI_AD12
- AD11 67 PCI_AD11
- AD10 69 PCI_AD10
- AD9 70 PCI_AD9
- AD8 71 PCI_AD8
- AD7 74 PCI_AD7
- AD6 76 PCI_AD6
- AD5 77 PCI_AD5
- AD4 79 PCI_AD4
- AD3 80 PCI_AD3
- AD2 81 PCI_AD2
- AD1 82 PCI_AD1
- AD0 84 PCI_AD0
- C/BE#3 34 PCI_C/BE3
- C/BE#2 47 PCI_C/BE2
- C/BE#1 60 PCI_C/BE1
- C/BE#0 73 PCI_C/BE0
- PCLK 1394 16 PCI_CLK
- GNT#2 18 PCI_GNT
- REQ#2 19 PCI_REQ
- 1394 IDSEL 36 PCI_IDSEL
- FRAME# 49 PCI_FRAME
- IRDY# 50 PCI_IRDY
- TRDY# 52 PCI_TRDY
- DEVSEL# 53 PCI_DEVSEL
- STOP# 54 PCI_STOP
- PERR# 56 PCI_PERR
- PIRQC# 13 PCI_INTA/CINT
- 1394 PME# 21 PCI_PME/CSTSCHG
- SERR# 57 PCI_SERR
- PAR 58 PCI_PAR
- 11,20,23,27,31 CLKRUN# 12 PCI_CLKRUN
- 4,10,14,20,21,23,25,27,31,34 PCIRST# 85 PCI_RST

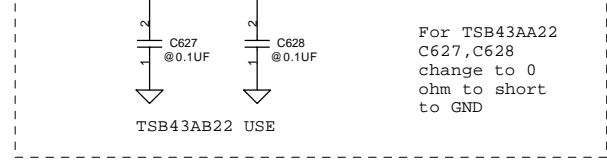
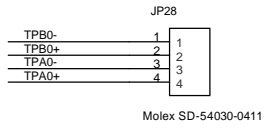
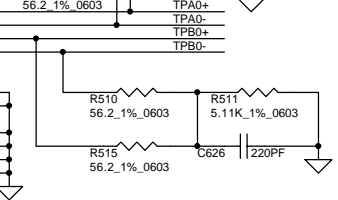
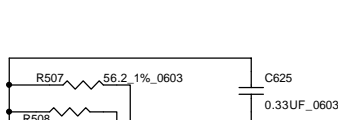
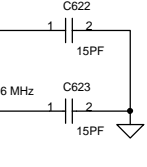
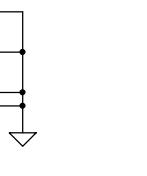
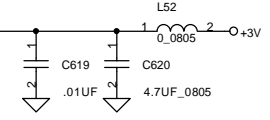
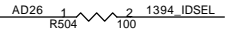
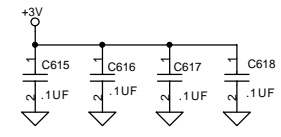
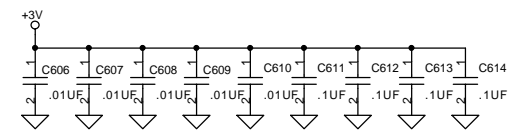

For TSB43AA22
C627, C628
change to 0
ohm to short
to GND

Compal Electronics, Inc.

Title: **SCHEMATIC, M/B LA-1391**

Size B Document Number **401211** Rev 1B

Date: 二月二十一日 26, 2002 Sheet 19 of 44

THIS SHEET OF ENGINEERING DRAWING IS THE PROPRIETARY PROPERTY OF COMPAL ELECTRONICS, INC. AND CONTAINS CONFIDENTIAL AND TRADE SECRET INFORMATION. THIS SHEET MAY NOT BE TRANSFERRED FROM THE CUSTODY OF THE COMPETENT DIVISION OF R&D DEPARTMENT EXCEPT AS AUTHORIZED BY COMPAL ELECTRONICS, INC. NEITHER THIS SHEET NOR THE INFORMATION IT CONTAINS MAY BE USED BY OR DISCLOSED TO ANY THIRD PARTY WITHOUT PRIOR WRITTEN CONSENT OF COMPAL ELECTRONICS, INC.

CardBus Controller OZ6933T (uBGA)

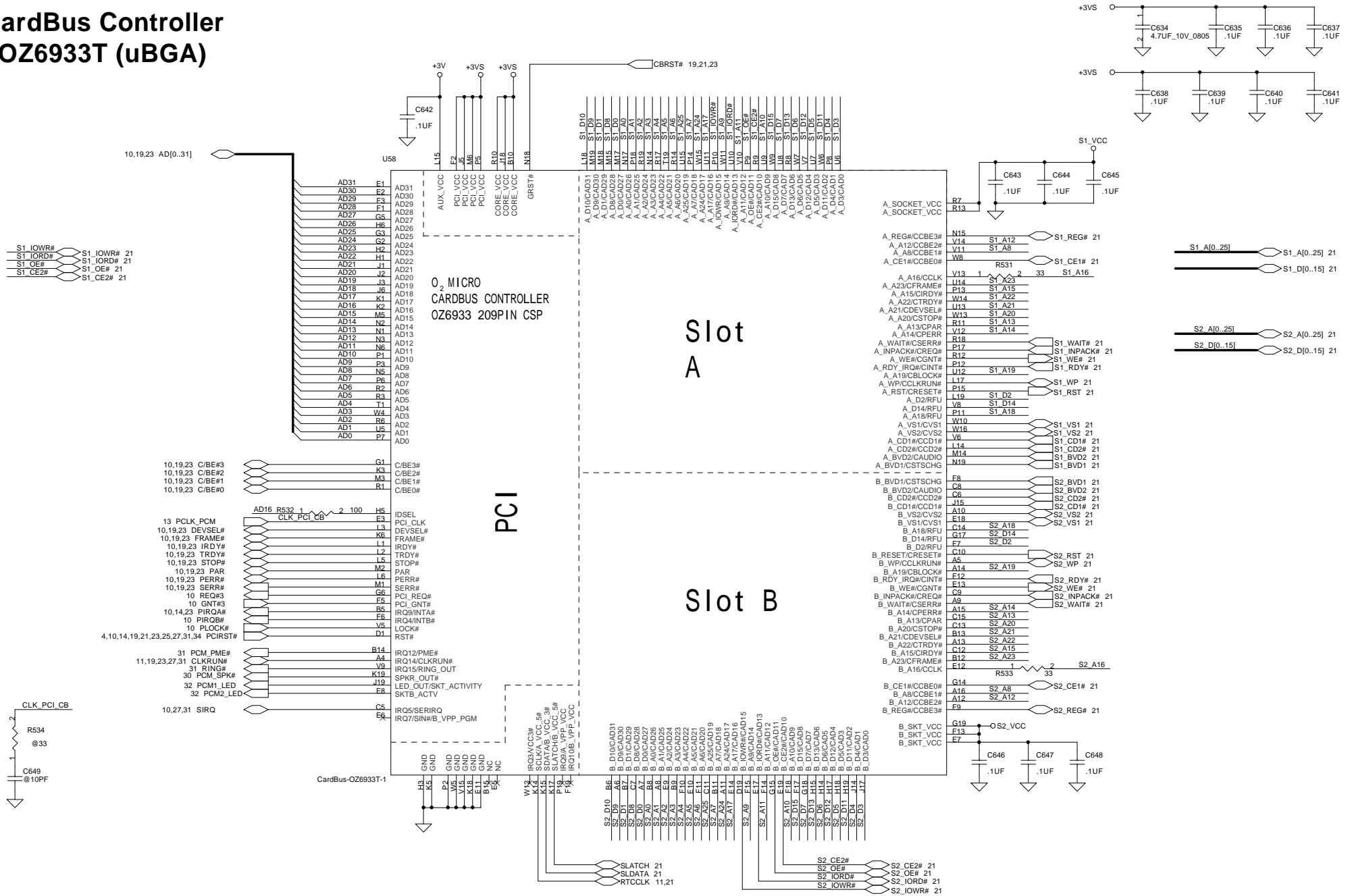

Compal Electronics, Inc.		
Title SCHEMATIC, M/B LA-1391		
Size Custom	Document Number 401211	Rev 1B
Date:	日期: 十一月 26, 2002	Sheet 20 of 44

PROPRIETARY NOTE: THIS SHEET OF ENGINEERING DRAWING IS THE PROPRIETARY PROPERTY OF COMPAL ELECTRONICS, INC. AND CONTAINS CONFIDENTIAL AND TRADE SECRET INFORMATION. THIS SHEET MAY NOT BE TRANSFERRED FROM THE CUSTODY OF THE COMPETENT DIVISION OF R&D DEPARTMENT EXCEPT AS AUTHORIZED BY COMPAL ELECTRONICS, INC. NEITHER THIS SHEET NOR THE INFORMATION IT CONTAINS MAY BE USED BY OR DISCLOSED TO ANY THIRD PARTY WITHOUT PRIOR WRITTEN CONSENT OF COMPAL ELECTRONICS, INC.

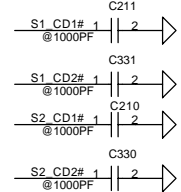
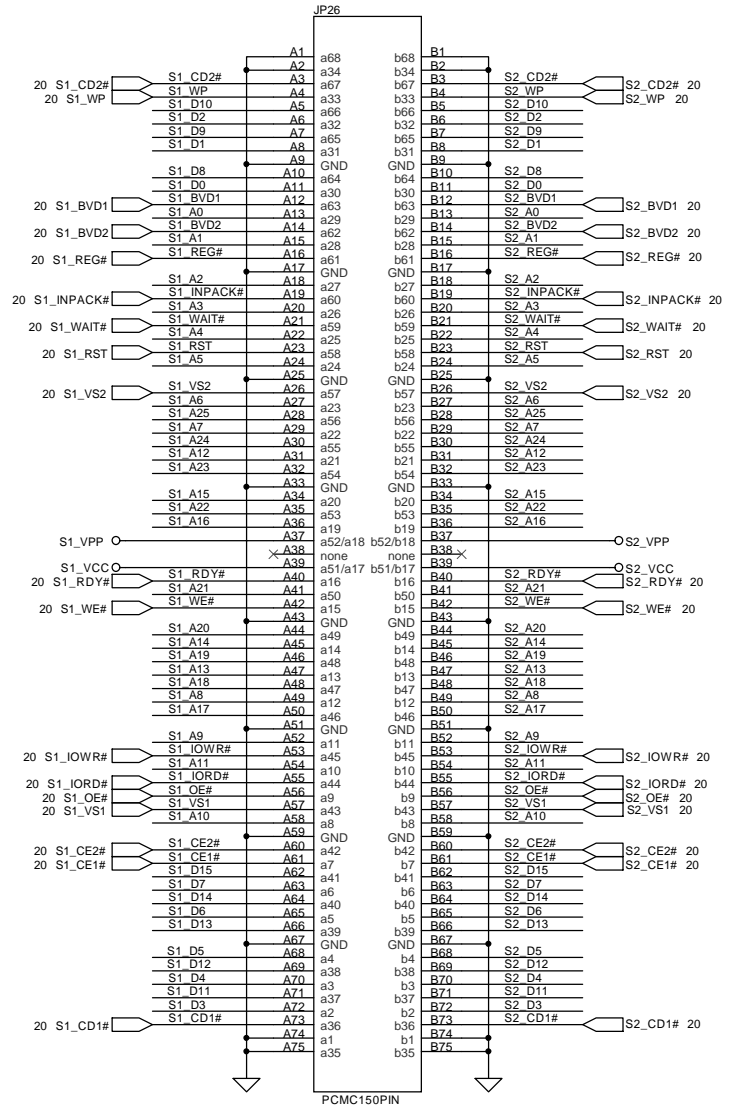
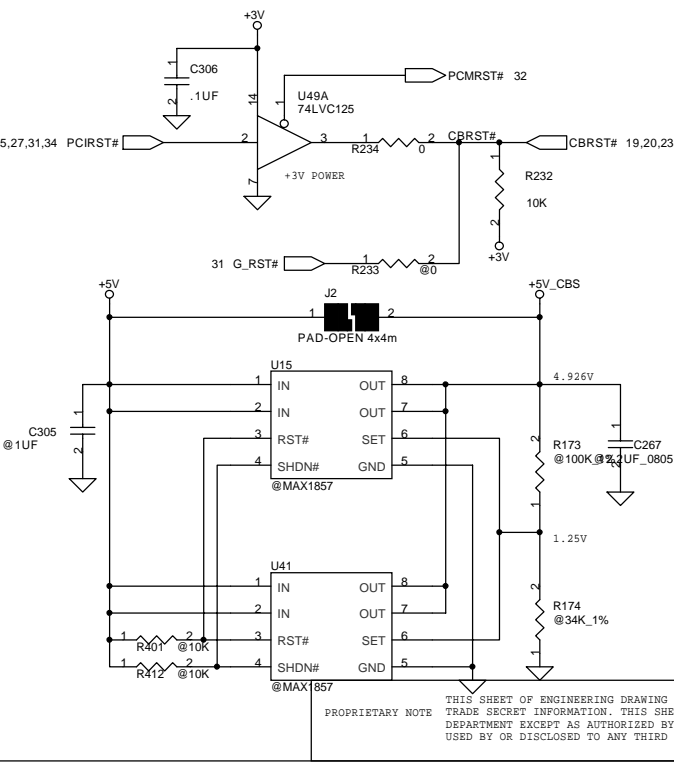
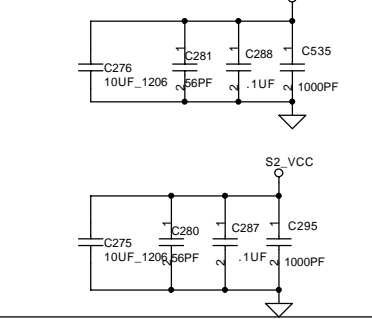
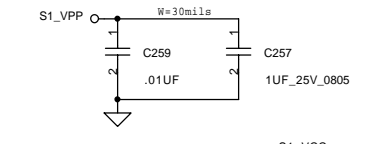
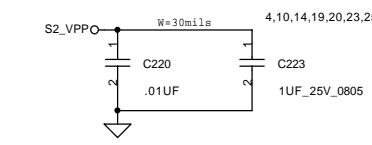
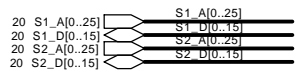
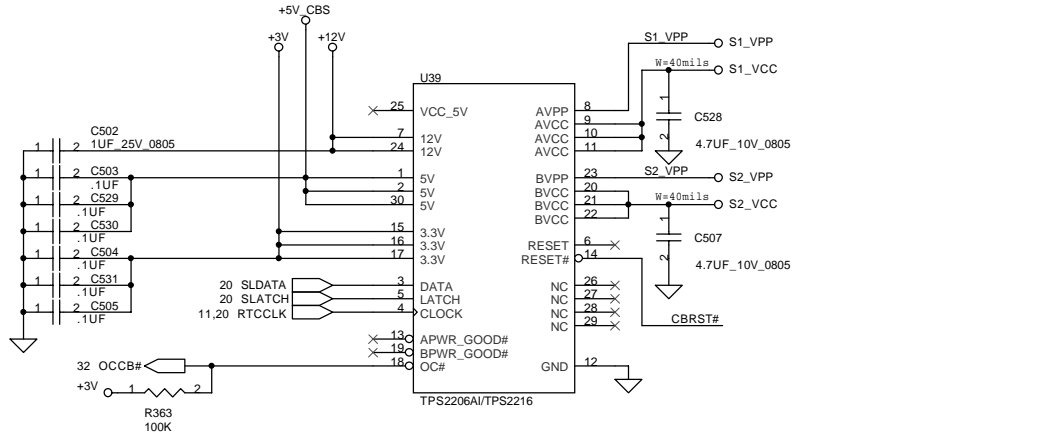

THIS SHEET OF ENGINEERING DRAWING IS THE PROPRIETARY PROPERTY OF COMPAL ELECTRONICS, INC. AND CONTAINS CONFIDENTIAL AND TRADE SECRET INFORMATION. THIS SHEET MAY NOT BE TRANSFERRED FROM THE CUSTODY OF THE COMPETENT DIVISION OF R&D DEPARTMENT EXCEPT AS AUTHORIZED BY COMPAL ELECTRONICS, INC. NEITHER THIS SHEET NOR THE INFORMATION IT CONTAINS MAY BE USED BY OR DISCLOSED TO ANY THIRD PARTY WITHOUT PRIOR WRITTEN CONSENT OF COMPAL ELECTRONICS, INC.

Compal Electronics, Inc.

Title: SCHEMATIC, M/B LA-1391

Size B	Document Number 401211	Rev 1B
Date: -P 期二,十一月26,2002	Sheet 21	of 44

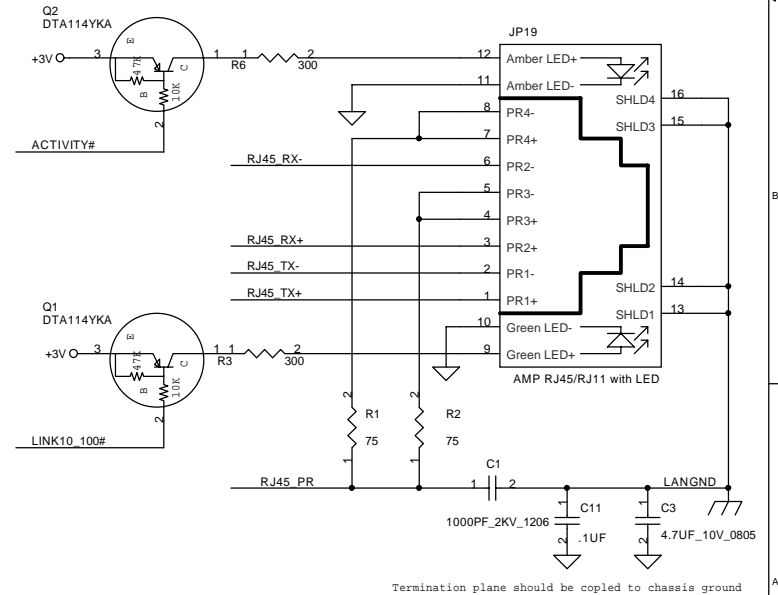
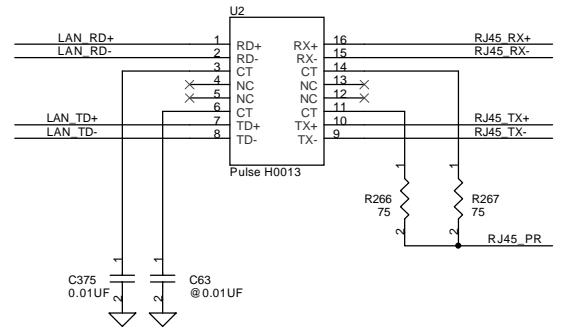
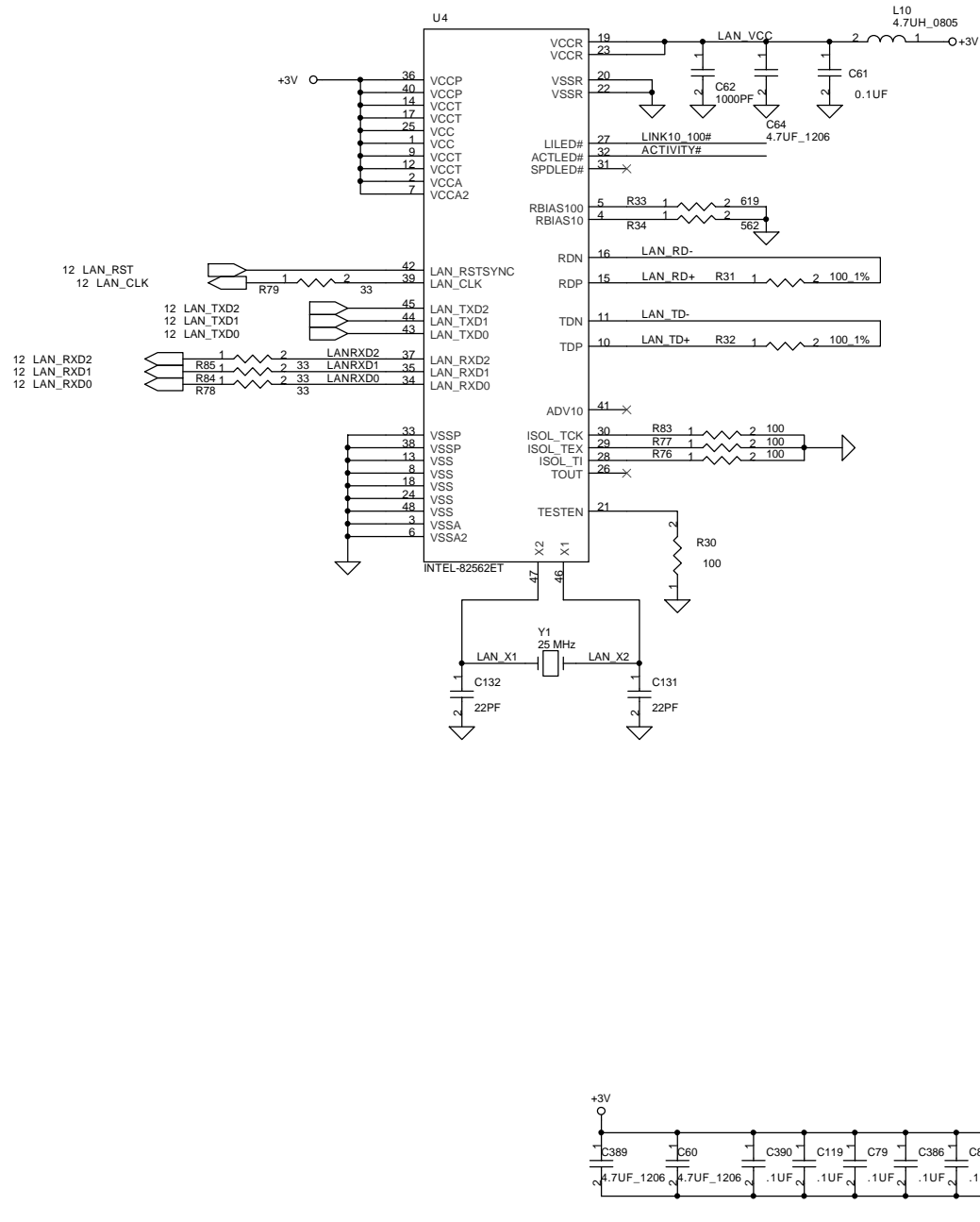

Compal Electronics, Inc.

Title		SCHEMATIC, M/B LA-1391	
Size	Document Number	401211	
Date	Rev	1B	
Date: 二月二十一日 2002		Sheet	22 of 44

THIS SHEET OF ENGINEERING DRAWING IS THE PROPRIETARY PROPERTY OF COMPAL ELECTRONICS, INC. AND CONTAINS CONFIDENTIAL AND PROPRIETARY INFORMATION. THIS SHEET MAY NOT BE TRANSFERRED FROM THE CUSTODY OF THE COMPETENT DIVISION OF R&D DEPARTMENT EXCEPT AS AUTHORIZED BY COMPAL ELECTRONICS, INC. NEITHER THIS SHEET NOR THE INFORMATION IT CONTAINS MAY BE USED BY OR DISCLOSED TO ANY THIRD PARTY WITHOUT PRIOR WRITTEN CONSENT OF COMPAL ELECTRONICS, INC.

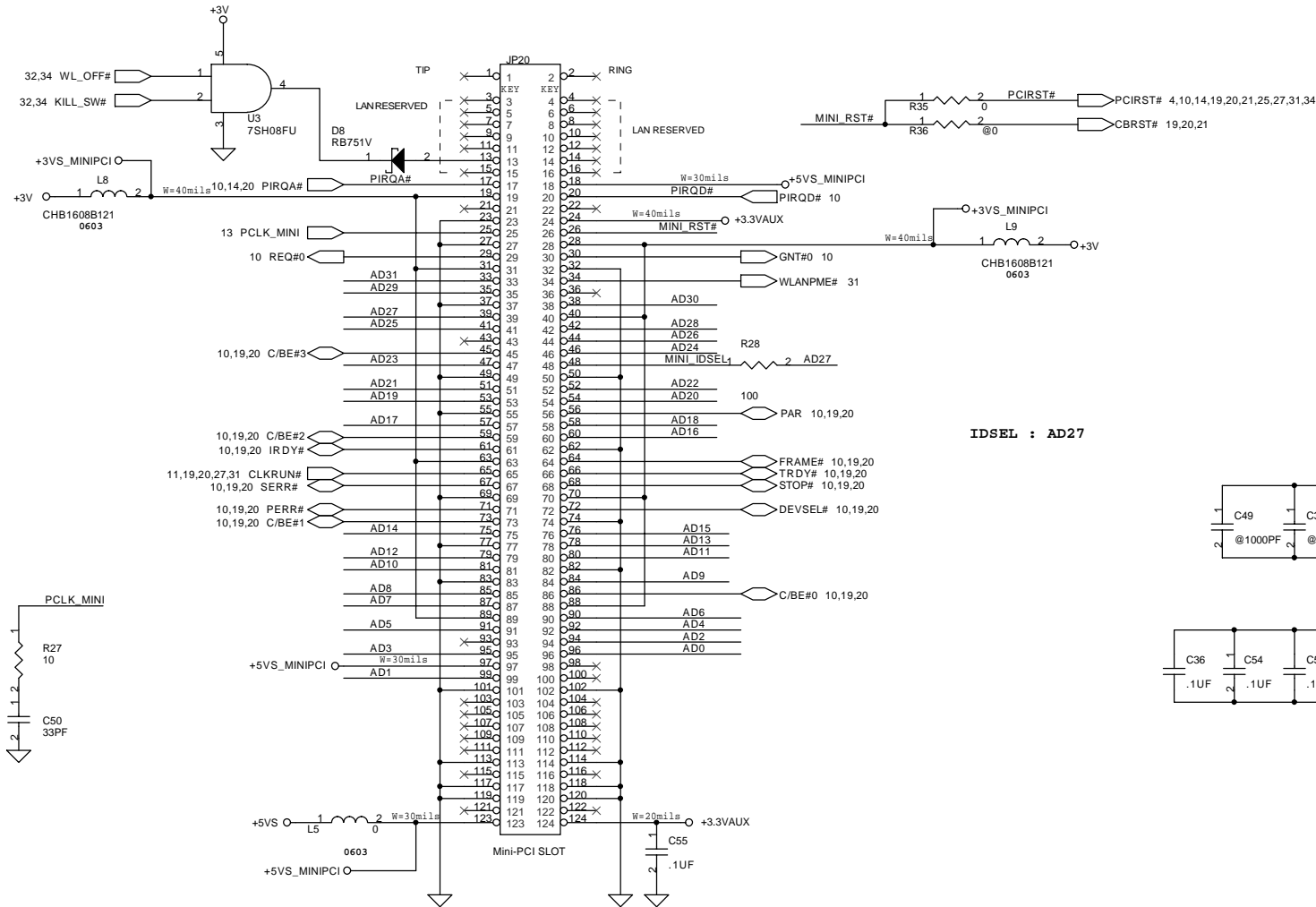
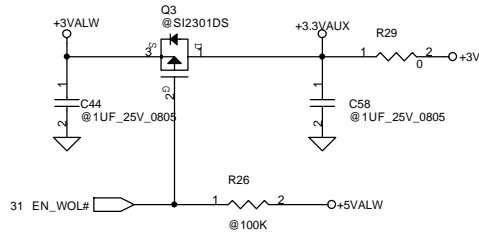

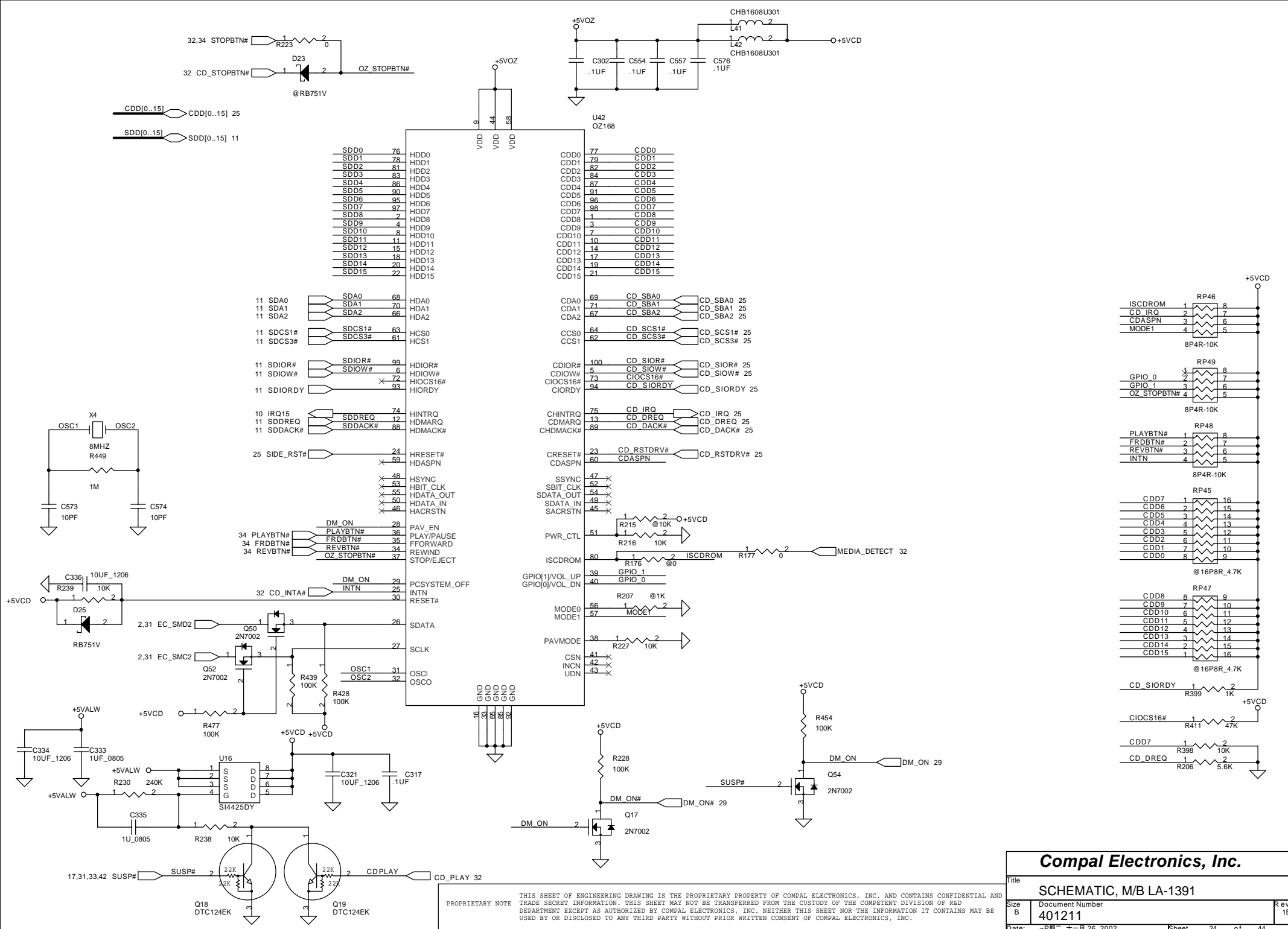

PROPRIETARY NOTE THIS SHEET OF ENGINEERING DRAWING IS THE PROPRIETARY PROPERTY OF COMPAL ELECTRONICS, INC. AND CONTAINS CONFIDENTIAL AND TRADE SECRET INFORMATION. THIS SHEET MAY NOT BE TRANSFERRED FROM THE CUSTODY OF THE COMPETENT DIVISION OF R&D DEPARTMENT EXCEPT AS AUTHORIZED BY COMPAL ELECTRONICS, INC. NEITHER THIS SHEET NOR THE INFORMATION IT CONTAINS MAY BE USED BY OR DISCLOSED TO ANY THIRD PARTY WITHOUT PRIOR WRITTEN CONSENT OF COMPAL ELECTRONICS, INC.

IDE, CD-ROM Module CONN.

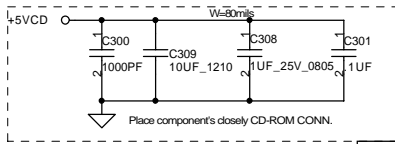
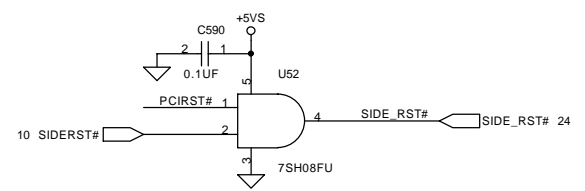
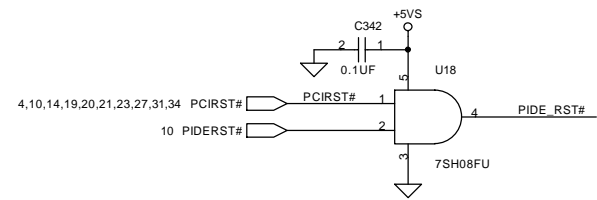
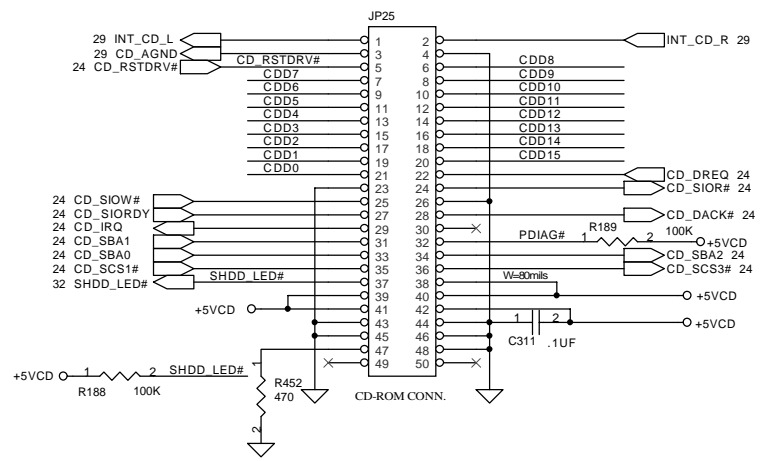
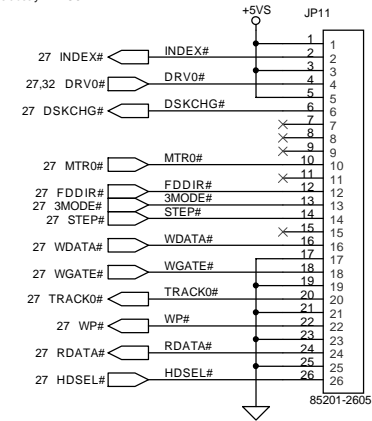
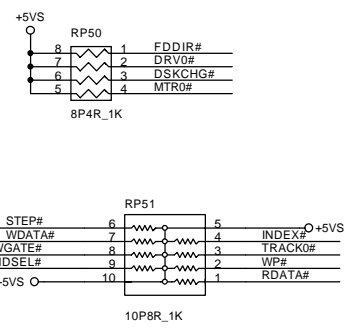
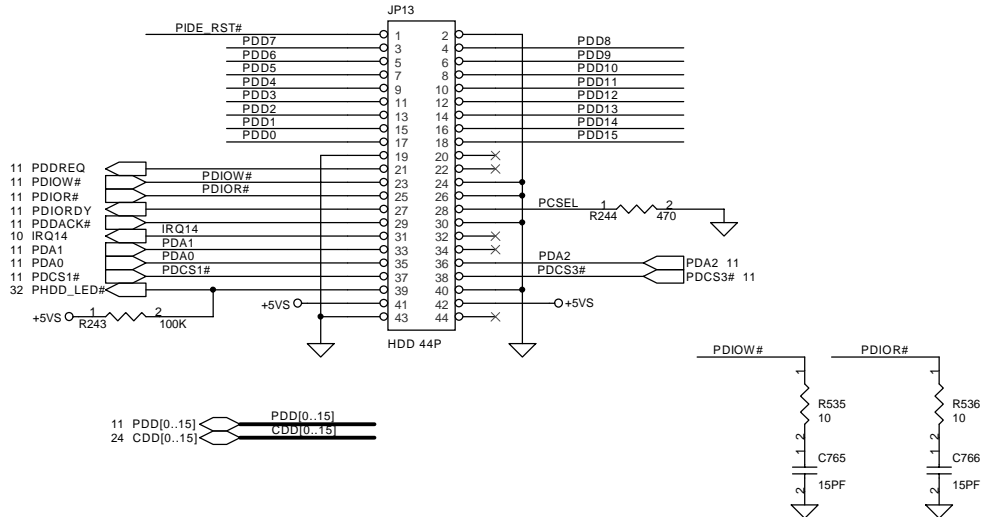
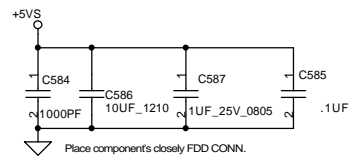
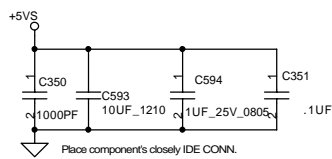

PROPRIETARY NOTE THIS SHEET OF ENGINEERING DRAWING IS THE PROPRIETARY PROPERTY OF COMPAL ELECTRONICS, INC. AND CONTAINS CONFIDENTIAL AND TRADE SECRET INFORMATION. THIS SHEET MAY NOT BE TRANSFERRED FROM THE CUSTODY OF THE COMPETENT DIVISION OF R&D DEPARTMENT EXCEPT AS AUTHORIZED BY COMPAL ELECTRONICS, INC. NEITHER THIS SHEET NOR THE INFORMATION IT CONTAINS MAY BE USED BY OR DISCLOSED TO ANY THIRD PARTY WITHOUT PRIOR WRITTEN CONSENT OF COMPAL ELECTRONICS, INC.

Compal Electronics, Inc.			
Title			
SCHEMATIC, M/B LA-1391			
Size	Document Number		Rev
B	401211		1B
Date:	-P 期二、十一月 26, 2002	Sheet	25 of 44

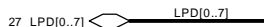
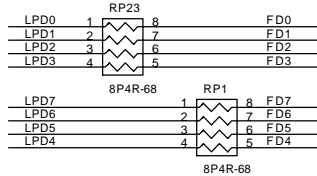
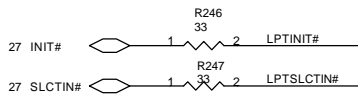
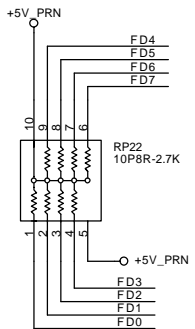
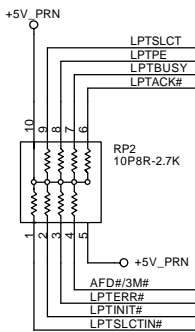
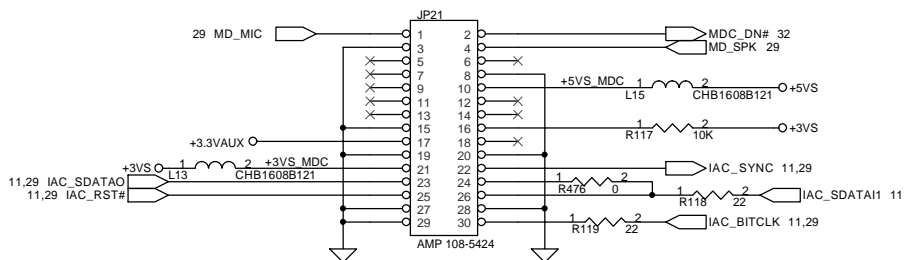

PARALLEL PORT

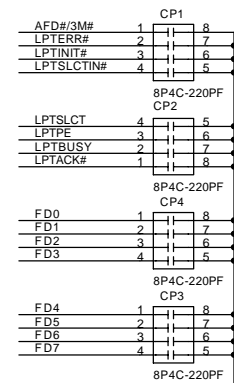
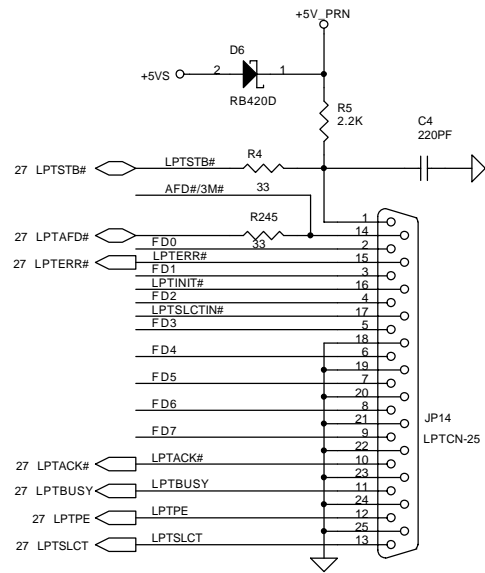

PROPRIETARY NOTE THIS SHEET OF ENGINEERING DRAWING IS THE PROPRIETARY PROPERTY OF COMPAL ELECTRONICS, INC. AND CONTAINS CONFIDENTIAL AND TRADE SECRET INFORMATION. THIS SHEET MAY NOT BE TRANSFERRED FROM THE CUSTODY OF THE COMPETENT DIVISION OF R&D DEPARTMENT EXCEPT AS AUTHORIZED BY COMPAL ELECTRONICS, INC. NEITHER THIS SHEET NOR THE INFORMATION IT CONTAINS MAY BE USED BY OR DISCLOSED TO ANY THIRD PARTY WITHOUT PRIOR WRITTEN CONSENT OF COMPAL ELECTRONICS, INC.

Compal Electronics, Inc.		
Title		
SCHEMATIC, M/B LA-1391		
Size	Document Number	Rev
	401211	1B
Date:	-P期二,十一月26,2002	Sheet 26 of 44

SUPER I/O SMC FDC47N227

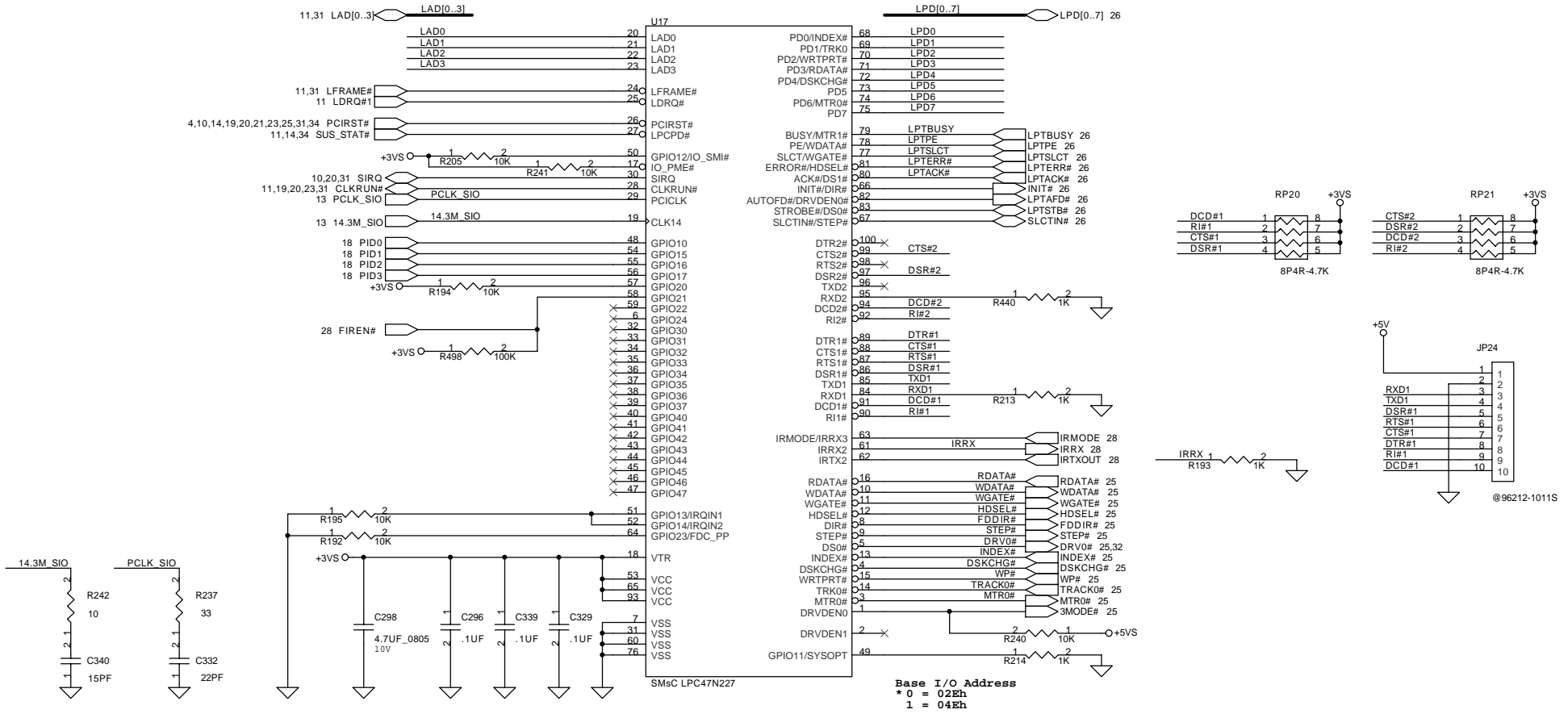

THIS SHEET OF ENGINEERING DRAWING IS THE PROPRIETARY PROPERTY OF COMPAL ELECTRONICS, INC. AND CONTAINS CONFIDENTIAL AND PROPRIETARY INFORMATION. THIS SHEET MAY NOT BE TRANSFERRED FROM THE CUSTODY OF THE COMPETENT DIVISION OF R&D DEPARTMENT EXCEPT AS AUTHORIZED BY COMPAL ELECTRONICS, INC. NEITHER THIS SHEET NOR THE INFORMATION IT CONTAINS MAY BE USED BY OR DISCLOSED TO ANY THIRD PARTY WITHOUT PRIOR WRITTEN CONSENT OF COMPAL ELECTRONICS, INC.

Compal Electronics, Inc.		
Title		
SCHEMATIC, M/B LA-1391		
Size	Document Number	Rev
B	401211	1B
Date:	日期: 十二月 26, 2002	Sheet 27 of 44

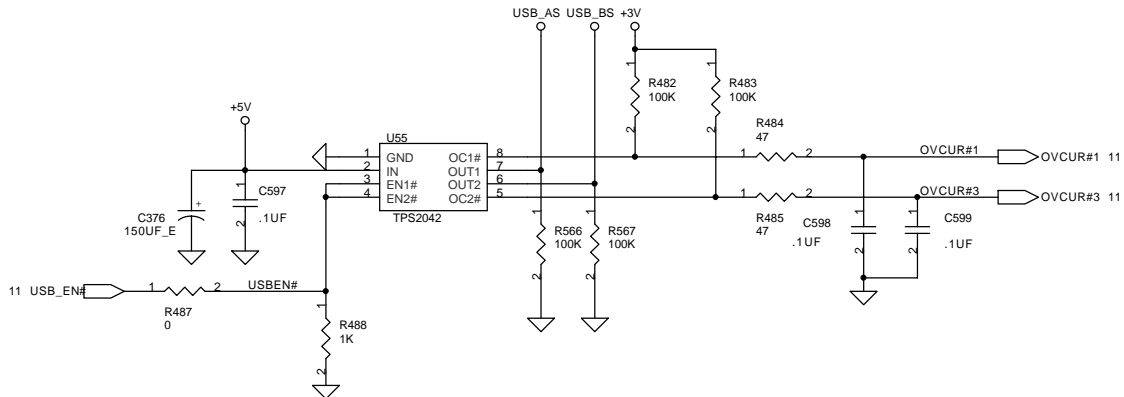
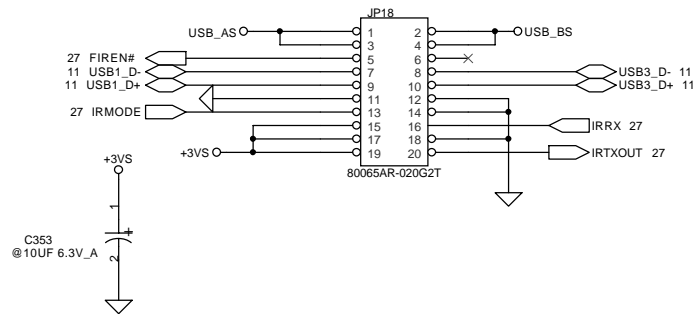

PROPRIETARY NOTE THIS SHEET OF ENGINEERING DRAWING IS THE PROPRIETARY PROPERTY OF COMPAL ELECTRONICS, INC. AND CONTAINS CONFIDENTIAL AND TRADE SECRET INFORMATION. THIS SHEET MAY NOT BE TRANSFERRED FROM THE CUSTODY OF THE COMPETENT DIVISION OF R&D DEPARTMENT EXCEPT AS AUTHORIZED BY COMPAL ELECTRONICS, INC. NEITHER THIS SHEET NOR THE INFORMATION IT CONTAINS MAY BE USED BY OR DISCLOSED TO ANY THIRD PARTY WITHOUT PRIOR WRITTEN CONSENT OF COMPAL ELECTRONICS, INC.

Compal Electronics, Inc.		
Title		
SCHEMATIC, M/B LA-1391		
Size	Document Number	Rev
B	401211	1B
Date:	-P 期二, 十一月 26, 2002	Sheet 28 of 44

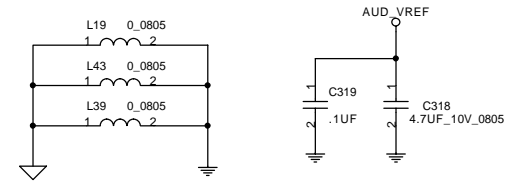
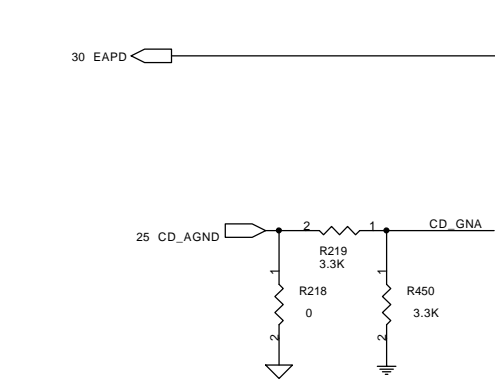
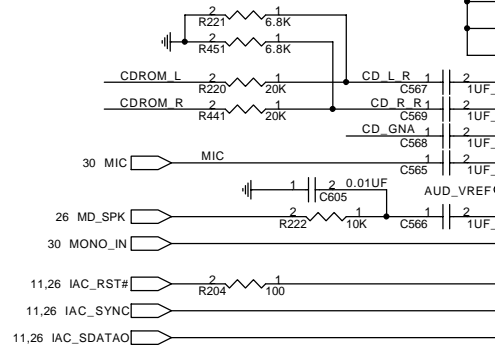
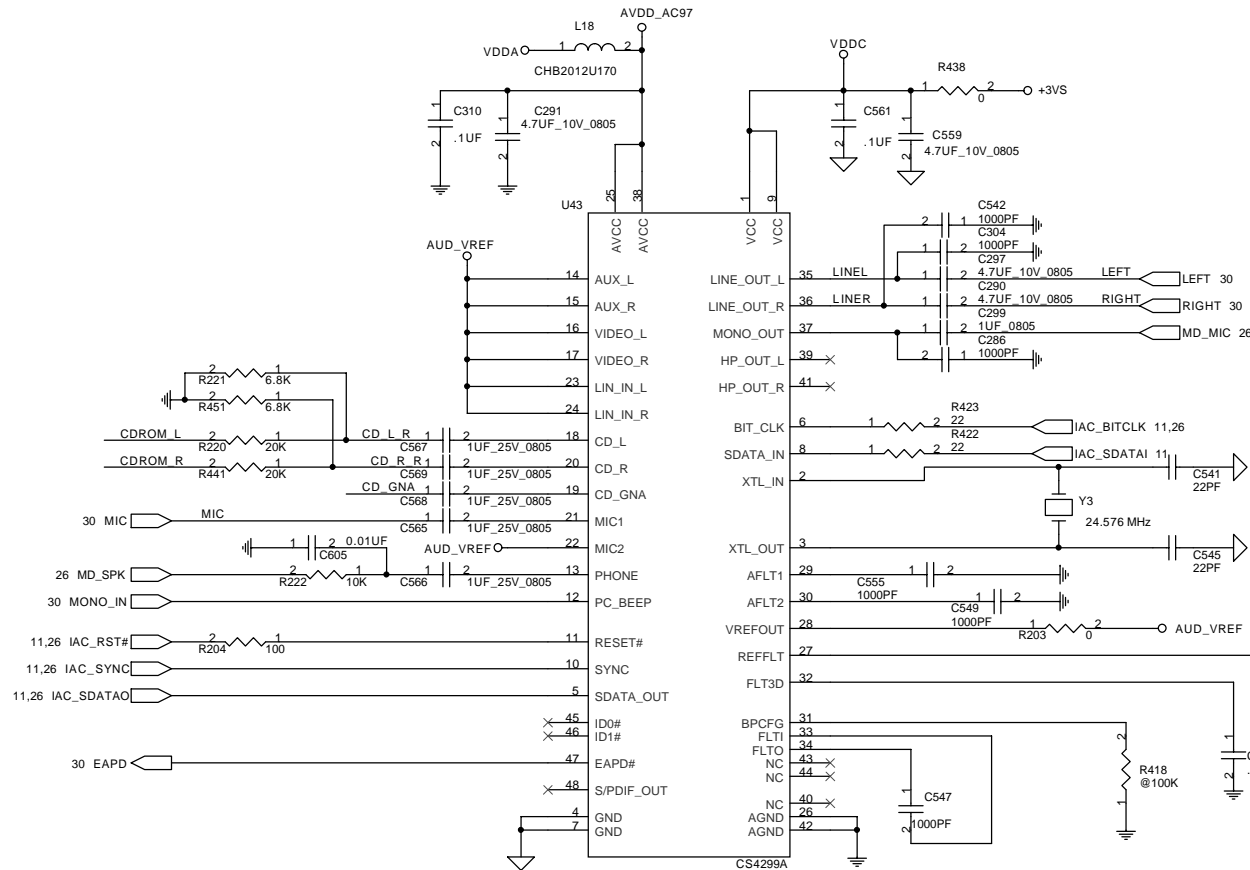
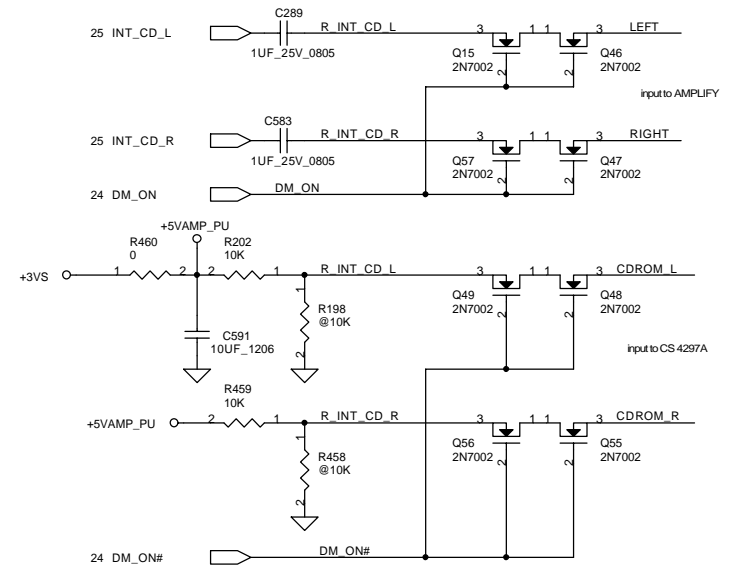
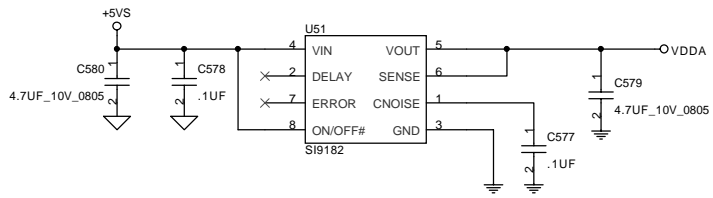

PROPRIETARY NOTE THIS SHEET OF ENGINEERING DRAWING IS THE PROPRIETARY PROPERTY OF COMPAL ELECTRONICS, INC. AND CONTAINS CONFIDENTIAL AND TRADE SECRET INFORMATION. THIS SHEET MAY NOT BE TRANSFERRED FROM THE CUSTODY OF THE COMPETENT DIVISION OF R&D DEPARTMENT EXCEPT AS AUTHORIZED BY COMPAL ELECTRONICS, INC. NEITHER THIS SHEET NOR THE INFORMATION IT CONTAINS MAY BE USED BY OR DISCLOSED TO ANY THIRD PARTY WITHOUT PRIOR WRITTEN CONSENT OF COMPAL ELECTRONICS, INC.

Compal Electronics, Inc.		
Title SCHEMATIC, MBLA-1391		
Size B	Document Number 401211	Rev 1B
Date: -P期二,十一月26,2002	Sheet 29 of 44	

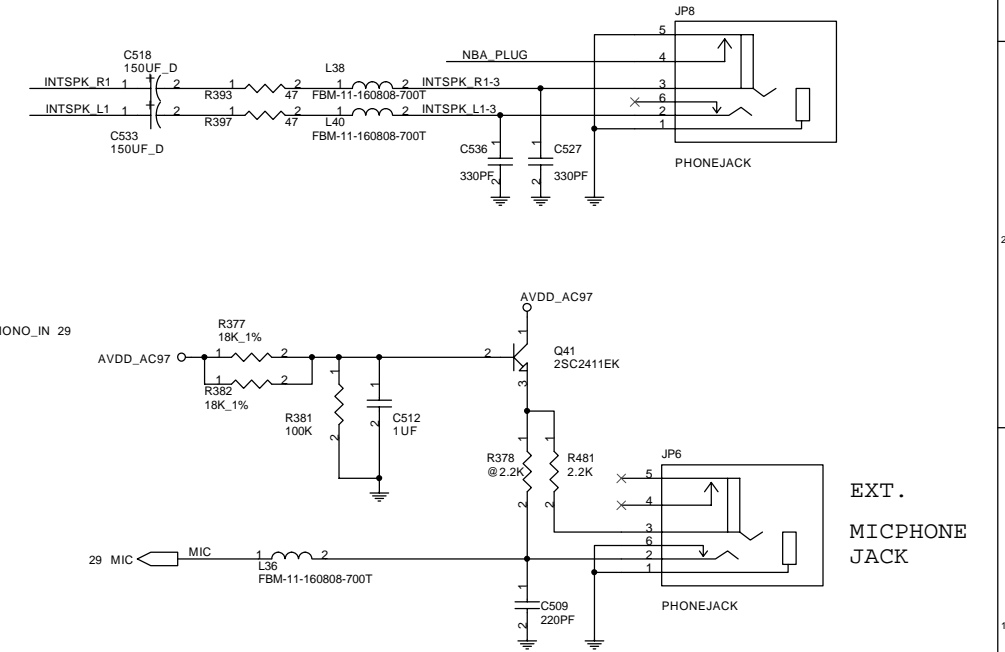
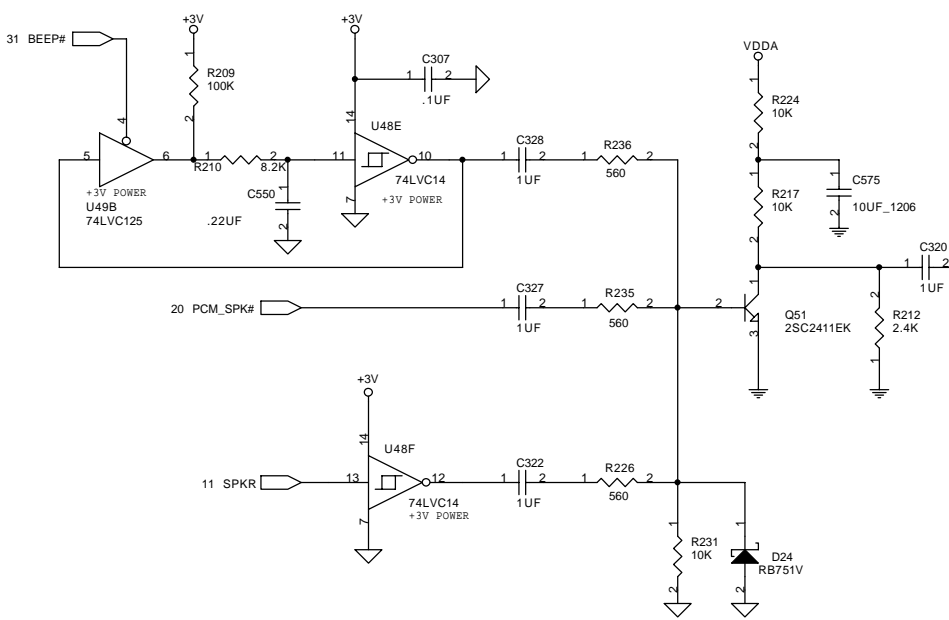
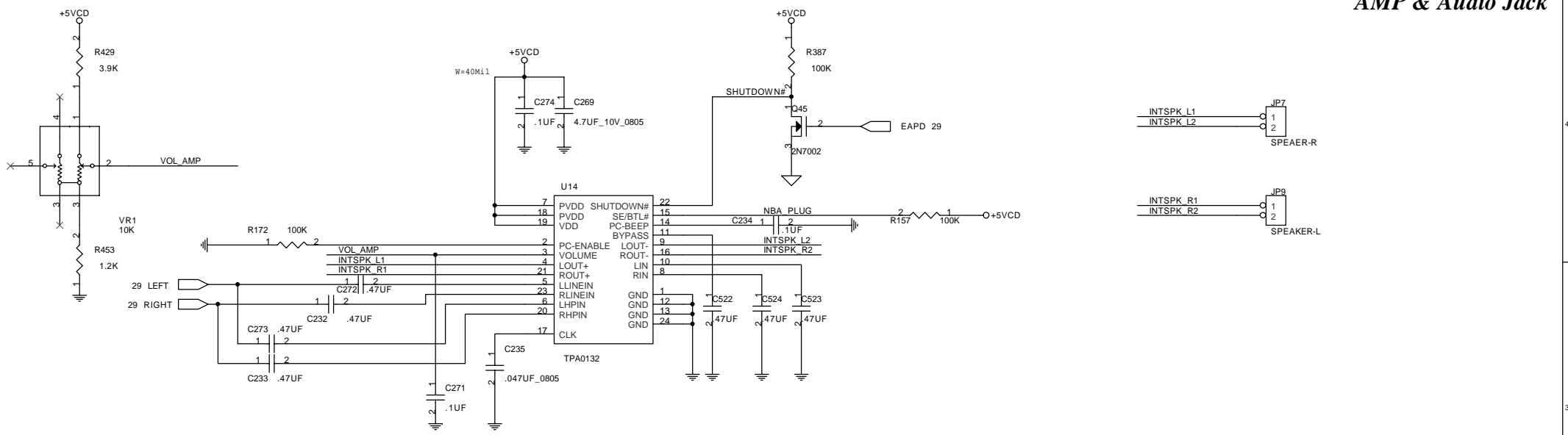

THIS SHEET OF ENGINEERING DRAWING IS THE PROPRIETARY PROPERTY OF COMPAL ELECTRONICS, INC. AND CONTAINS CONFIDENTIAL AND PROPRIETARY INFORMATION. THIS SHEET MAY NOT BE TRANSFERRED FROM THE CUSTODY OF THE COMPETENT DIVISION OF R&D DEPARTMENT EXCEPT AS AUTHORIZED BY COMPAL ELECTRONICS, INC. NEITHER THIS SHEET NOR THE INFORMATION IT CONTAINS MAY BE USED BY OR DISCLOSED TO ANY THIRD PARTY WITHOUT PRIOR WRITTEN CONSENT OF COMPAL ELECTRONICS, INC.

Compal Electronics, Inc. Title SCHEMATIC, M/B LA-1391		
Size B	Document Number 401211	Rev 1B
Date: ~P期二,十一月26,2002		Sheet 30 of 44

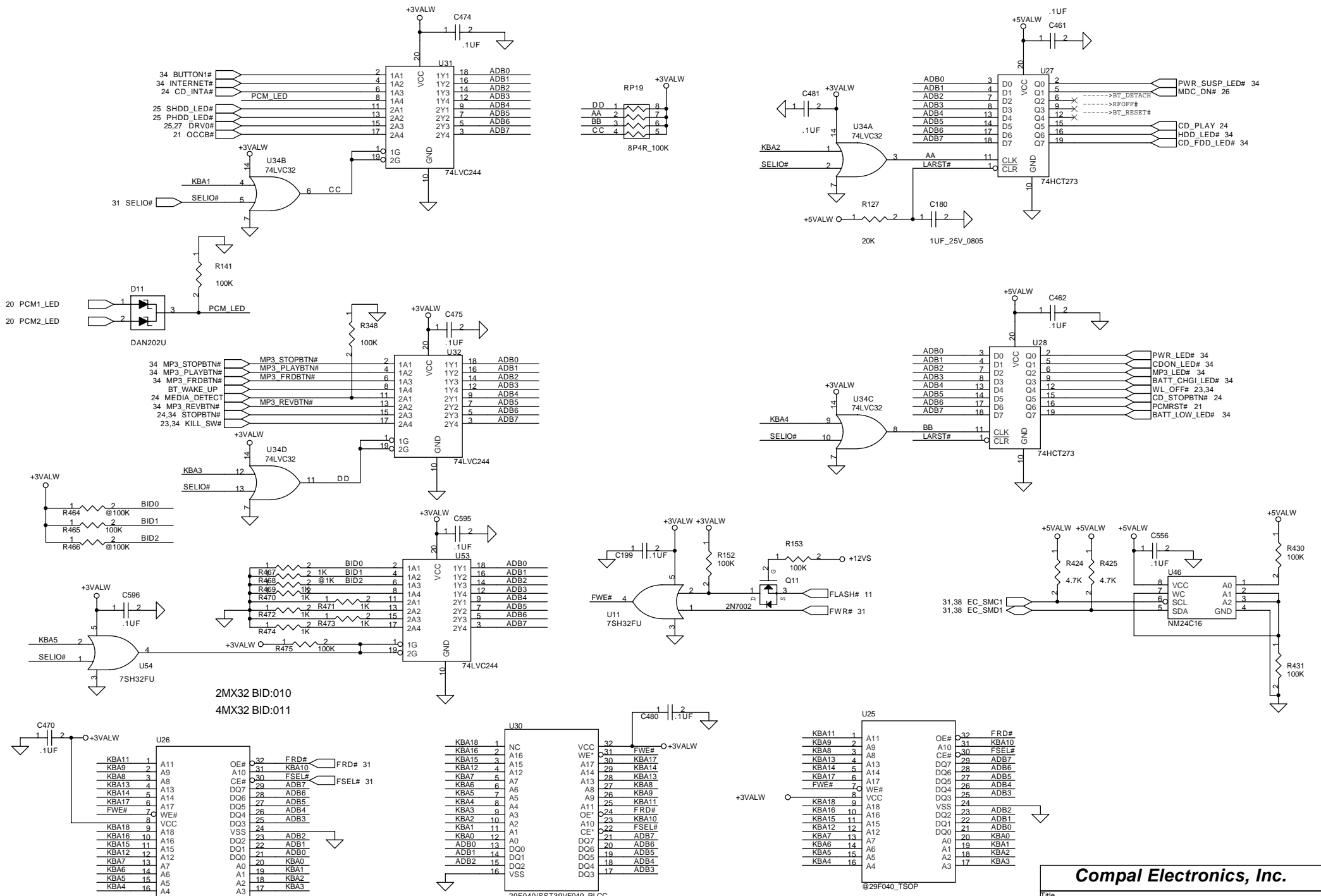

Compal Electronics, Inc.

Title: **SCHEMATIC, M/B LA-1391**

Size: **Document Number 401211**

Date: **-P 星期三, 十一月 27, 2002** Sheet **32** of **44**

THIS SHEET OF ENGINEERING DRAWING IS THE PROPRIETARY PROPERTY OF COMPAL ELECTRONICS, INC. AND CONTAINS CONFIDENTIAL AND TRADE SECRET INFORMATION. THIS SHEET MAY NOT BE TRANSFERRED FROM THE CUSTODY OF THE COMPETENT DIVISION OF R&D DEPARTMENT EXCEPT AS AUTHORIZED BY COMPAL ELECTRONICS, INC. NEITHER THIS SHEET NOR THE INFORMATION IT CONTAINS MAY BE USED BY OR DISCLOSED TO ANY THIRD PARTY WITHOUT PRIOR WRITTEN CONSENT OF COMPAL ELECTRONICS, INC.

31 KBA[0..18] KBA[0..18]
31 ADB[0..7] ADB[0..7]

2MX32 BID:010
4MX32 BID:011

@SST39VF040_TSOP

29F040/SST39VF040 PLCC

@29F040_TSOP

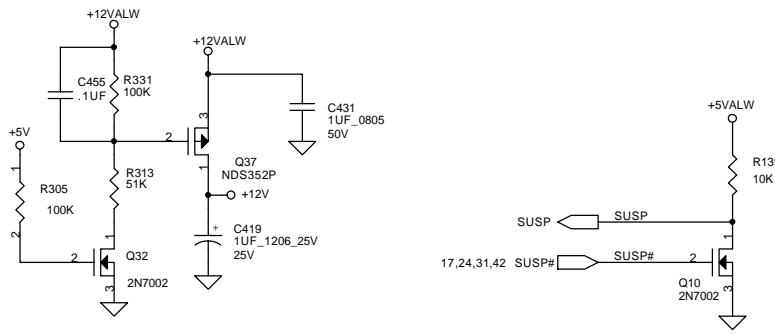
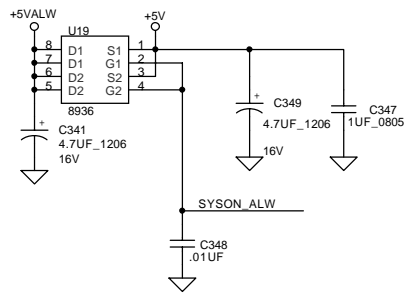
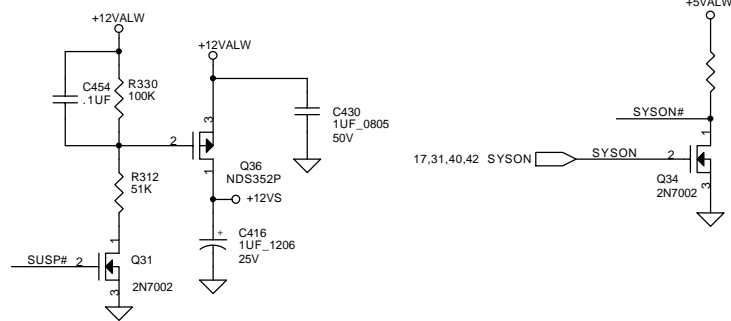
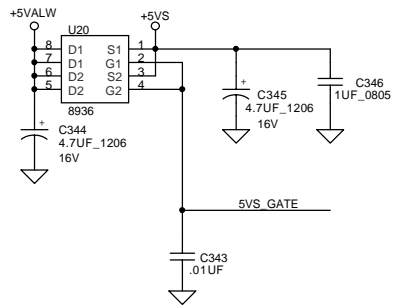
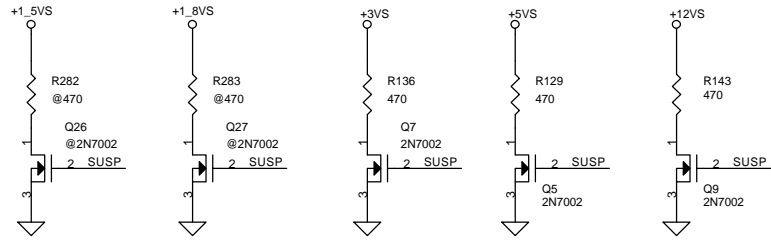
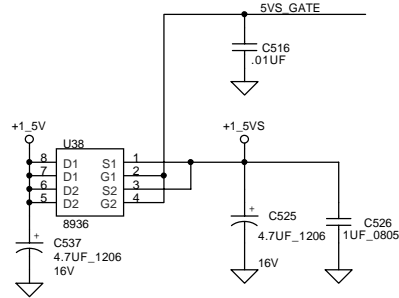
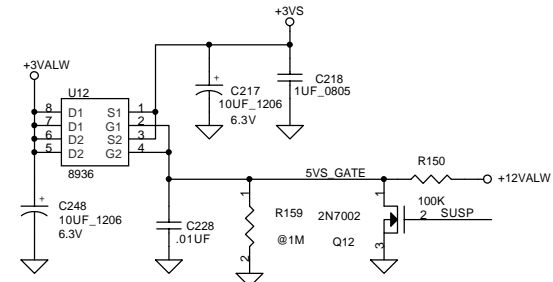
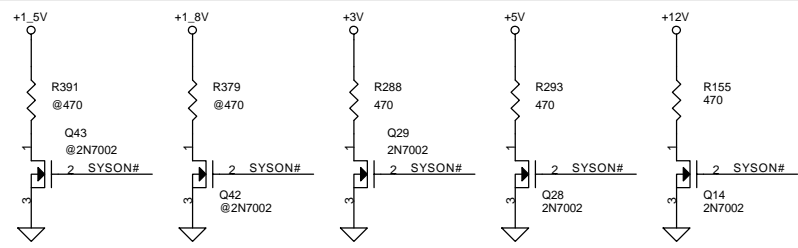
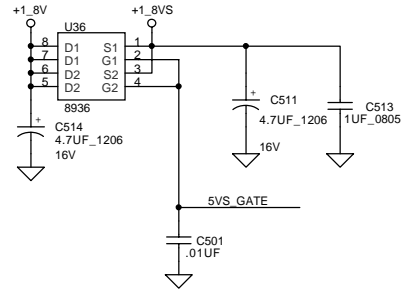
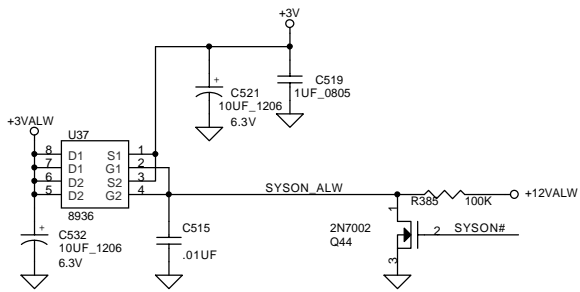

Compal Electronics, Inc.		
Title		
SCHEMATIC, M/B LA-1391		
Size	Document Number	Rev
B	401211	1B
Date:	-日期-	Sheet
-日期-	十一月 26, 2002	33 of 44

THIS SHEET OF ENGINEERING DRAWING IS THE PROPRIETARY PROPERTY OF COMPAL ELECTRONICS, INC. AND CONTAINS CONFIDENTIAL AND TRADE SECRET INFORMATION. THIS SHEET MAY NOT BE TRANSFERRED FROM THE CUSTODY OF THE COMPETENT DIVISION OF R&D DEPARTMENT EXCEPT AS AUTHORIZED BY COMPAL ELECTRONICS, INC. NEITHER THIS SHEET NOR THE INFORMATION IT CONTAINS MAY BE USED BY OR DISCLOSED TO ANY THIRD PARTY WITHOUT PRIOR WRITTEN CONSENT OF COMPAL ELECTRONICS, INC.

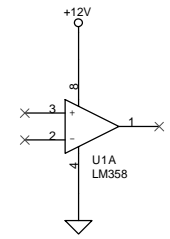
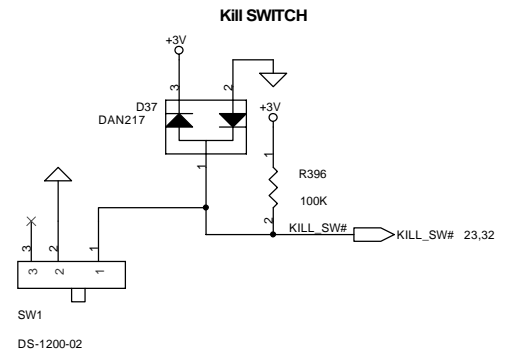
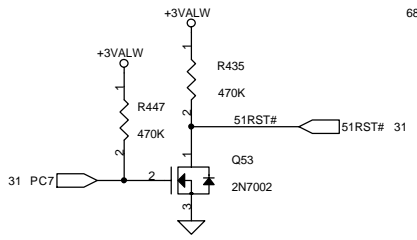
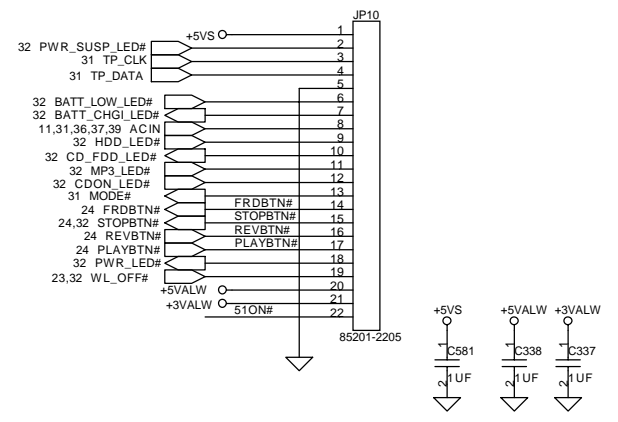
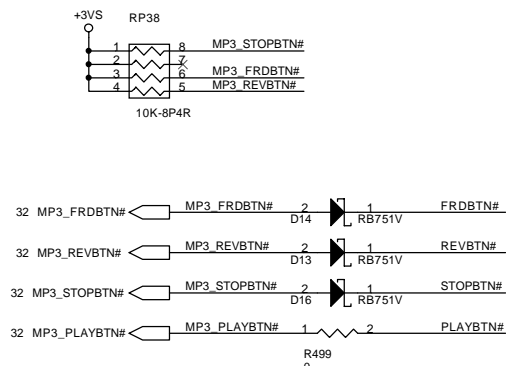
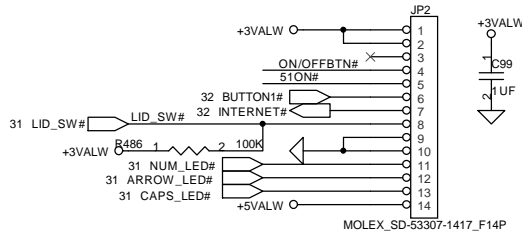

FAN CONN.

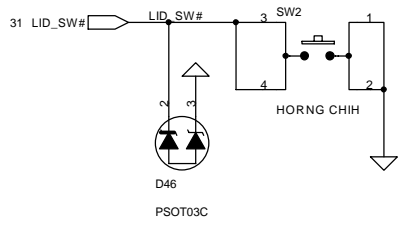
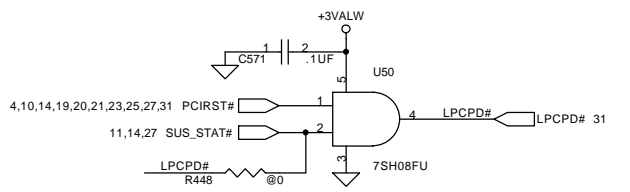
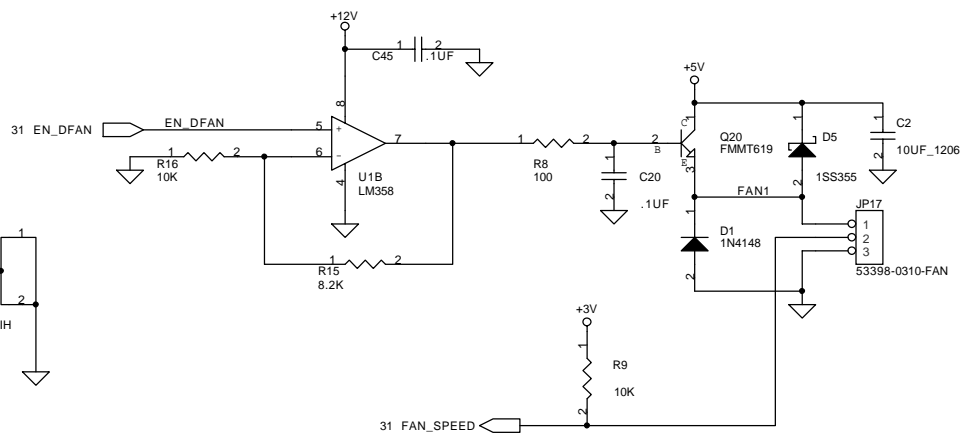
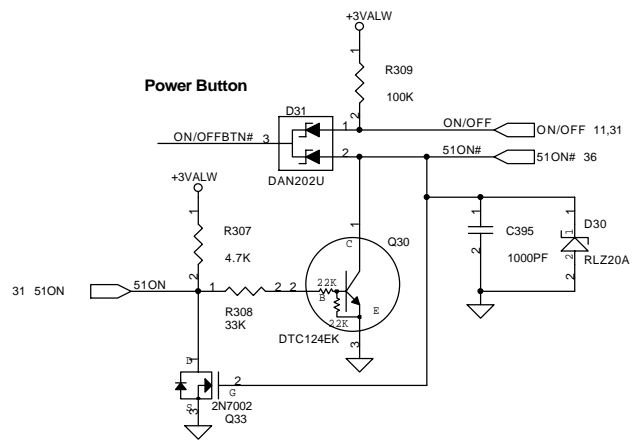

For PC87591 REV 0.A Only

Compal Electronics, Inc.

Title		SCHEMATIC, M/B LA-1391	
Size	Document Number	401211	
Date:	Rev	1B	
Date: 二期, 十一月 26, 2002		Sheet	34 of 44

THIS SHEET OF ENGINEERING DRAWING IS THE PROPRIETARY PROPERTY OF COMPAL ELECTRONICS, INC. AND CONTAINS CONFIDENTIAL AND TRADE SECRET INFORMATION. THIS SHEET MAY NOT BE TRANSFERRED FROM THE CUSTODY OF THE COMPETENT DIVISION OF R&D DEPARTMENT EXCEPT AS AUTHORIZED BY COMPAL ELECTRONICS, INC. NEITHER THIS SHEET NOR THE INFORMATION IT CONTAINS MAY BE USED BY OR DISCLOSED TO ANY THIRD PARTY WITHOUT PRIOR WRITTEN CONSENT OF COMPAL ELECTRONICS, INC.

Vin Detector

High 18.764 17.901 17.063
Low 17.745 16.903 16.038

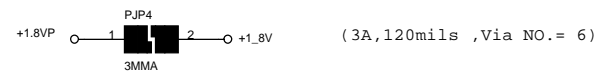
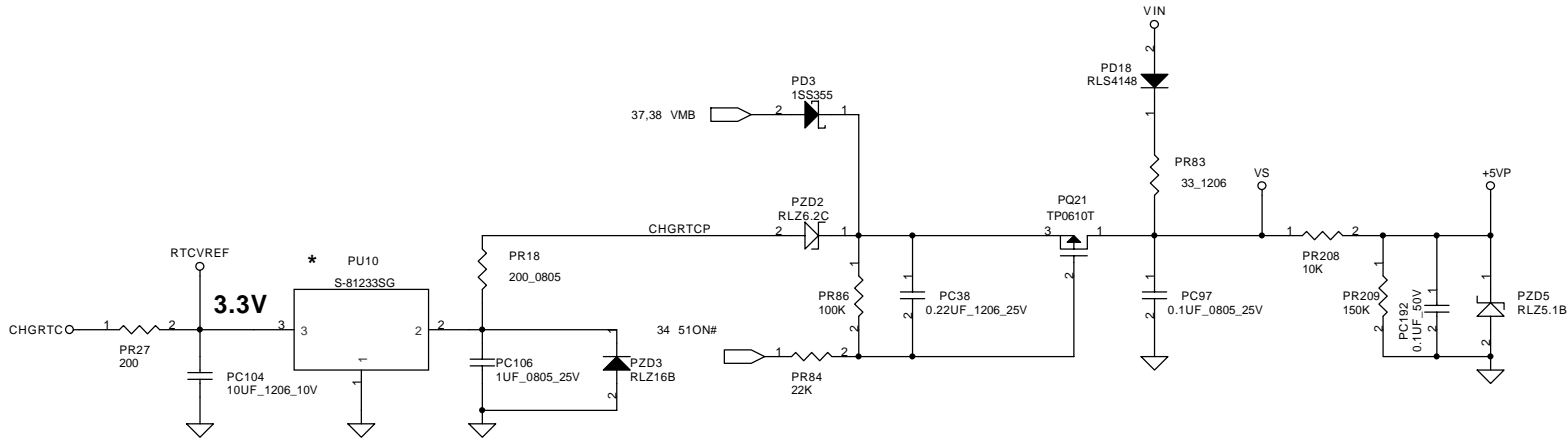
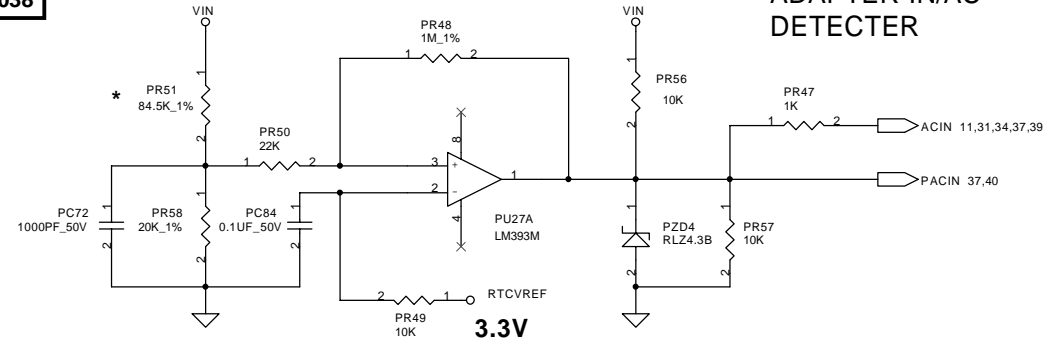
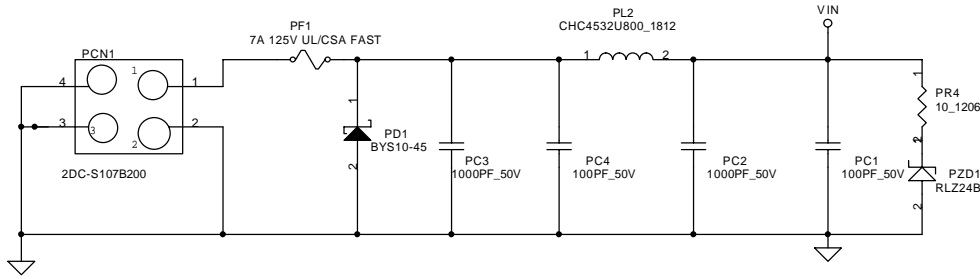

THIS SHEET OF ENGINEERING DRAWING IS THE PROPRIETARY PROPERTY OF COMPAL ELECTRONICS, INC. AND CONTAINS CONFIDENTIAL AND TRADE SECRET INFORMATION. THIS SHEET MAY NOT BE TRANSFERRED FROM THE CUSTODY OF THE COMPETENT DIVISION OF R&D DEPARTMENT EXCEPT AS AUTHORIZED BY COMPAL ELECTRONICS, INC. NEITHER THIS SHEET NOR THE INFORMATION IT CONTAINS MAY BE USED BY OR DISCLOSED TO ANY THIRD PARTY WITHOUT PRIOR WRITTEN CONSENT OF COMPAL ELECTRONICS, INC.

Compal Electronics, Inc.

Title		SCHEMATIC, M/B LA-1391	
Size	Document Number	R ev	
B	401211	1B	
Date:	2002年11月26日	Sheet	36 of 44

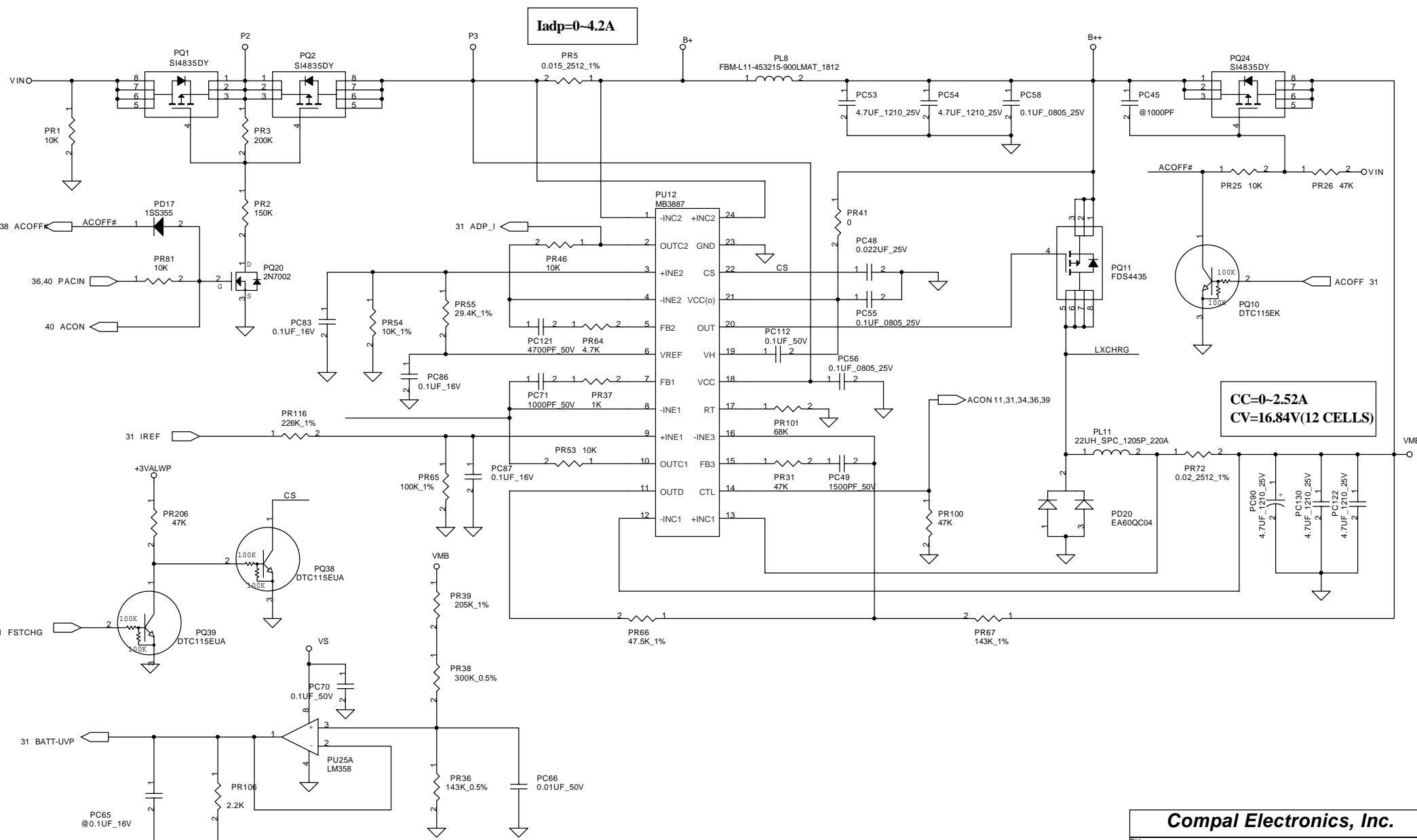

THIS SHEET OF ENGINEERING DRAWING IS THE PROPRIETARY PROPERTY OF COMPAL ELECTRONICS, INC. AND CONTAINS CONFIDENTIAL AND TRADE SECRET INFORMATION. THIS SHEET MAY NOT BE TRANSFERRED FROM THE CUSTODY OF THE COMPETENT DIVISION OF R&D DEPARTMENT EXCEPT AS AUTHORIZED BY COMPAL ELECTRONICS, INC. NEITHER THIS SHEET NOR THE INFORMATION IT CONTAINS MAY BE USED BY OR DISCLOSED TO ANY THIRD PARTY WITHOUT PRIOR WRITTEN CONSENT OF COMPAL ELECTRONICS, INC.

Compal Electronics, Inc.		
Title	SCHEMATIC, M/B LA-1391	
Size	Document Number	R ev
B	401211	1B
Date:	-P 期二 十一月 26, 2002	Sheet 37 of 44

12 Cells Charger OVP : 18.059V

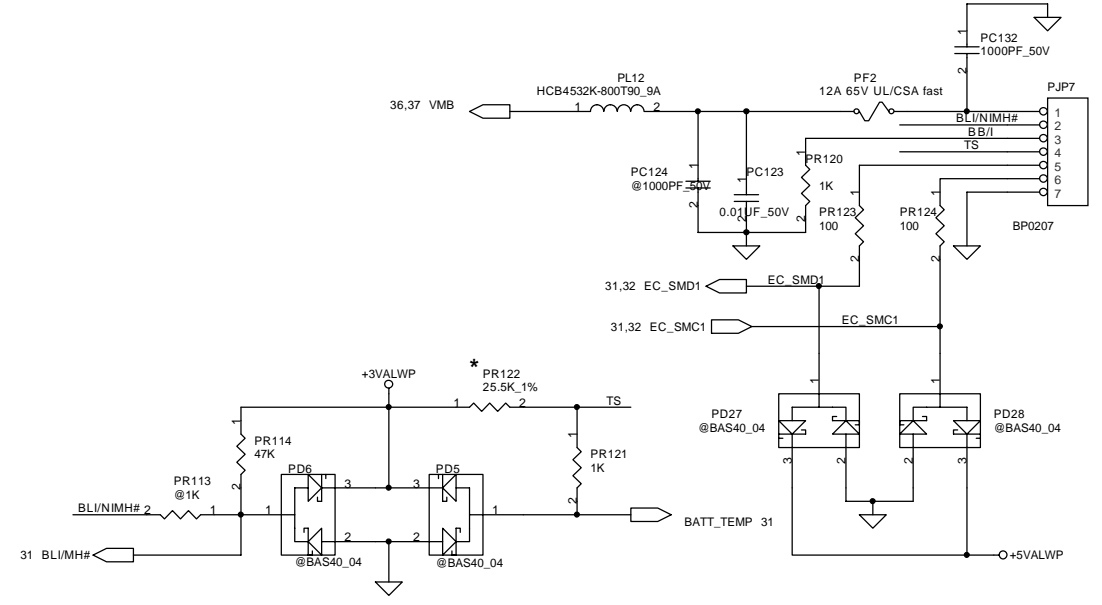
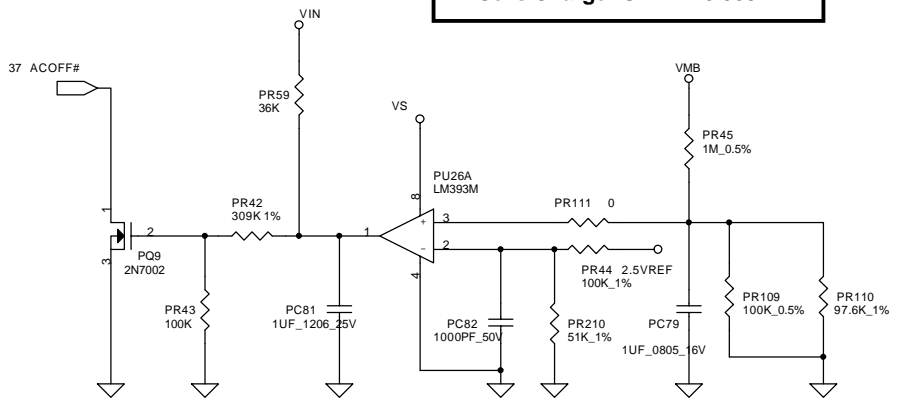

PH1 under CPU botten side :
 CPU thermal protection at 76 degree C
 Recovery at 45 degree C

PH2 near main Battery CONN :
 BAT. thermal protection at 82 degree C
 Recovery at 45 degree C

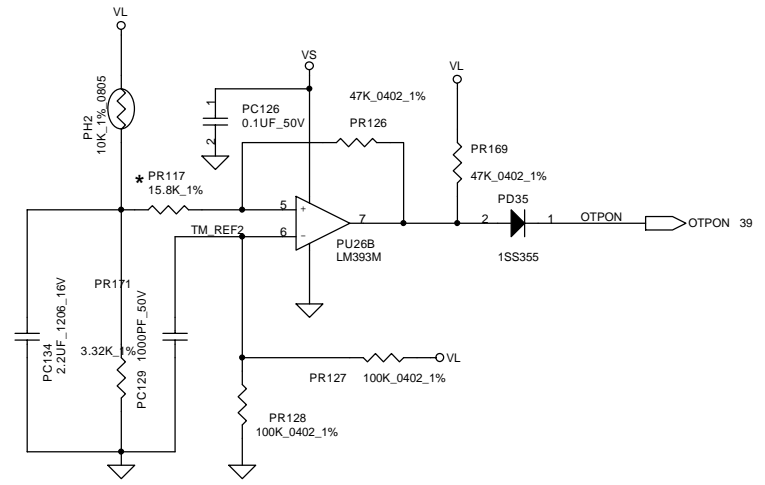
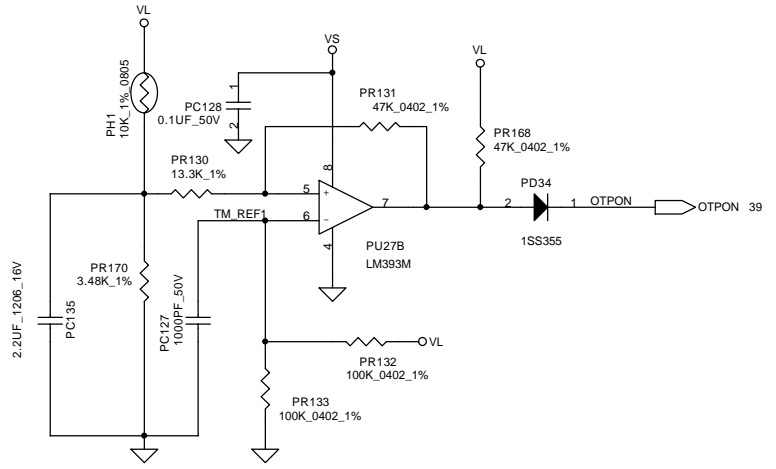

THIS SHEET OF ENGINEERING DRAWING IS THE PROPRIETARY PROPERTY OF COMPAL ELECTRONICS, INC. AND CONTAINS CONFIDENTIAL AND TRADE SECRET INFORMATION. THIS SHEET MAY NOT BE TRANSFERRED FROM THE CUSTODY OF THE COMPETENT DIVISION OF R&D DEPARTMENT EXCEPT AS AUTHORIZED BY COMPAL ELECTRONICS, INC. NEITHER THIS SHEET NOR THE INFORMATION IT CONTAINS MAY BE USED BY OR DISCLOSED TO ANY THIRD PARTY WITHOUT PRIOR WRITTEN CONSENT OF COMPAL ELECTRONICS, INC.

Compal Electronics, Inc.		
Title		
SCHEMATIC, M/B LA-1391		
Size	Document Number	Rev
B	401211	1B
Date:	-P期二,十一月26,2002	Sheet 38 of 44

+3.3V Ipeak = 6.66A ~ 10A

+5V Ipeak = 6.66A ~ 10A

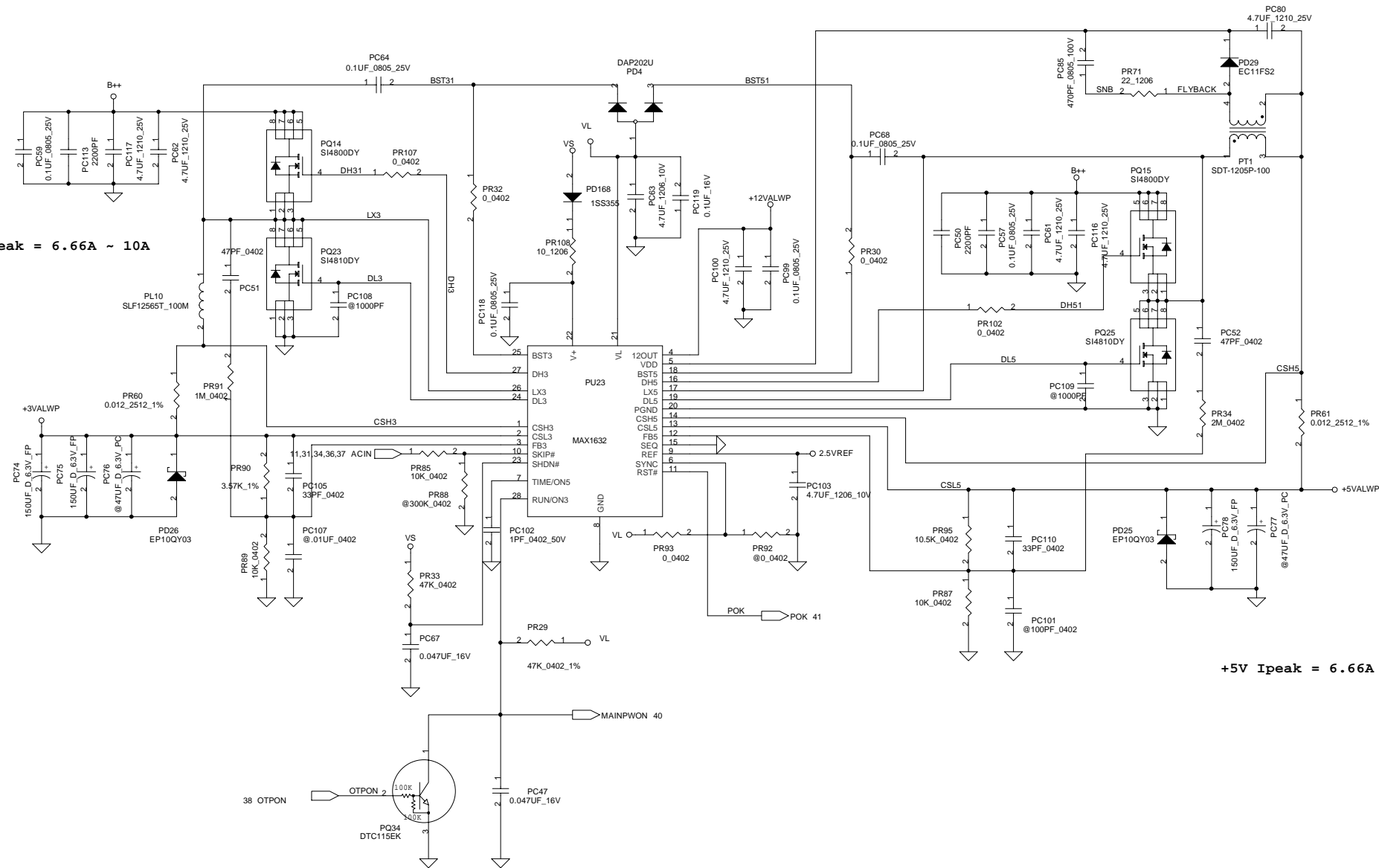

THIS SHEET OF ENGINEERING DRAWING IS THE PROPRIETARY PROPERTY OF COMPAL ELECTRONICS, INC. AND CONTAINS CONFIDENTIAL AND TRADE SECRET INFORMATION. THIS SHEET MAY NOT BE TRANSFERRED FROM THE CUSTODY OF THE COMPETENT DIVISION OF R&D DEPARTMENT EXCEPT AS AUTHORIZED BY COMPAL ELECTRONICS, INC. NEITHER THIS SHEET NOR THE INFORMATION IT CONTAINS MAY BE USED BY OR DISCLOSED TO ANY THIRD PARTY WITHOUT PRIOR WRITTEN CONSENT OF COMPAL ELECTRONICS, INC.

Compal Electronics, Inc.		
SCHEMATIC, M/B LA-1391		
Size	Document Number	Rev
	401211	1B
Date:	星期二, 十一月 26, 2002	Sheet 39 of 44

+1.8VP+-5%

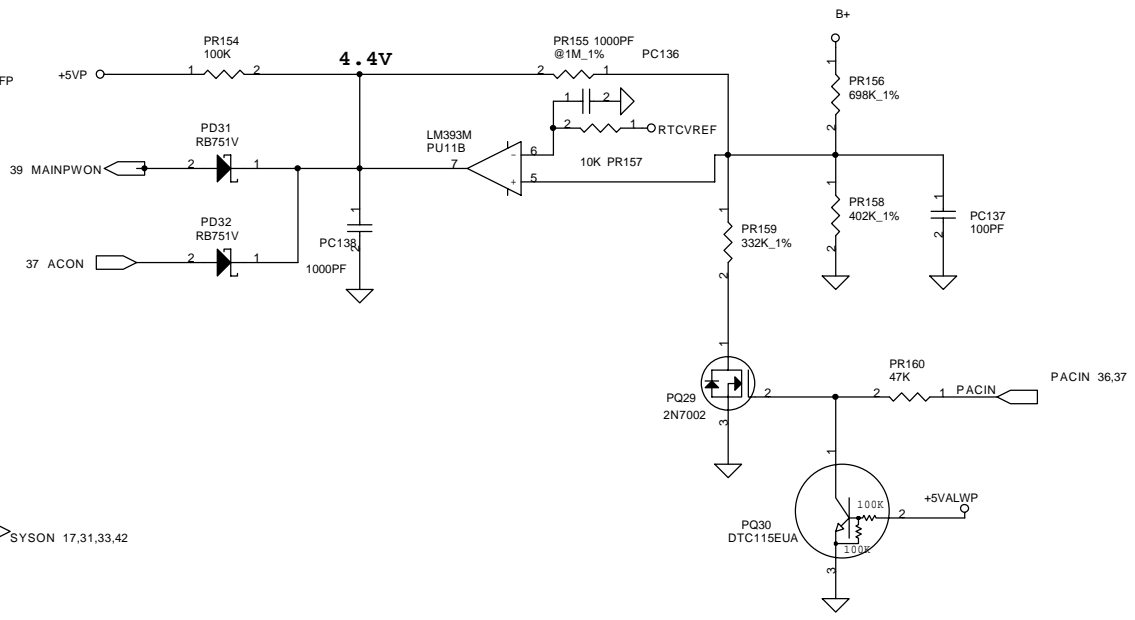
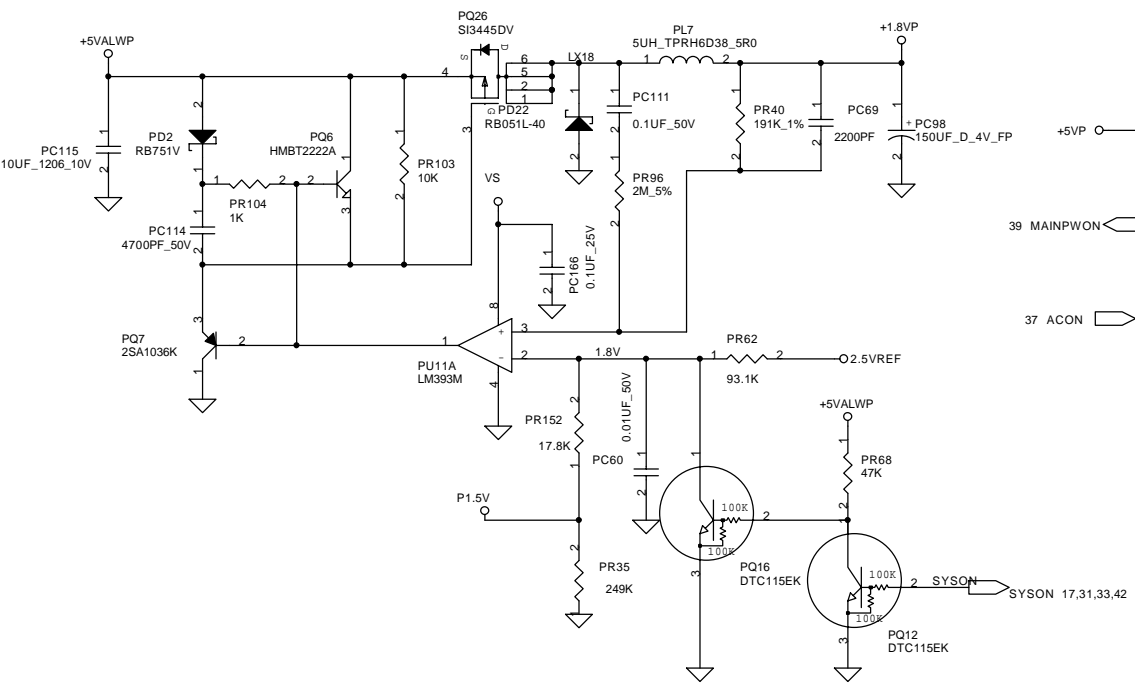

+1.5VS+-5%

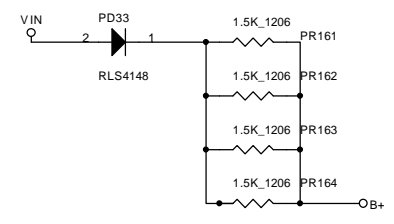
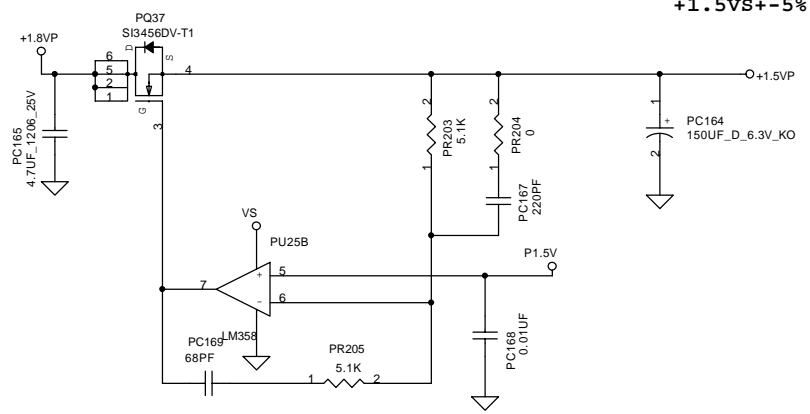

THIS SHEET OF ENGINEERING DRAWING IS THE PROPRIETARY PROPERTY OF COMPAL ELECTRONICS, INC. AND CONTAINS CONFIDENTIAL AND TRADE SECRET INFORMATION. THIS SHEET MAY NOT BE TRANSFERRED FROM THE CUSTODY OF THE COMPETENT DIVISION OF R&D DEPARTMENT EXCEPT AS AUTHORIZED BY COMPAL ELECTRONICS, INC. NEITHER THIS SHEET NOR THE INFORMATION IT CONTAINS MAY BE USED BY OR DISCLOSED TO ANY THIRD PARTY WITHOUT PRIOR WRITTEN CONSENT OF COMPAL ELECTRONICS, INC.

Compal Electronics, Inc.			
Title SCHEMATIC, M/B LA-1391			
Size B	Document Number 401211	Rev 1B	
Date: 二月二十六日, 2002		Sheet	40 of 44

+2.5V/+1.25V

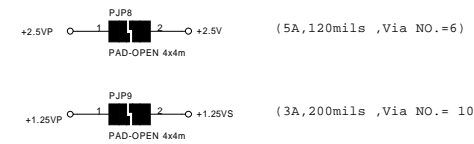
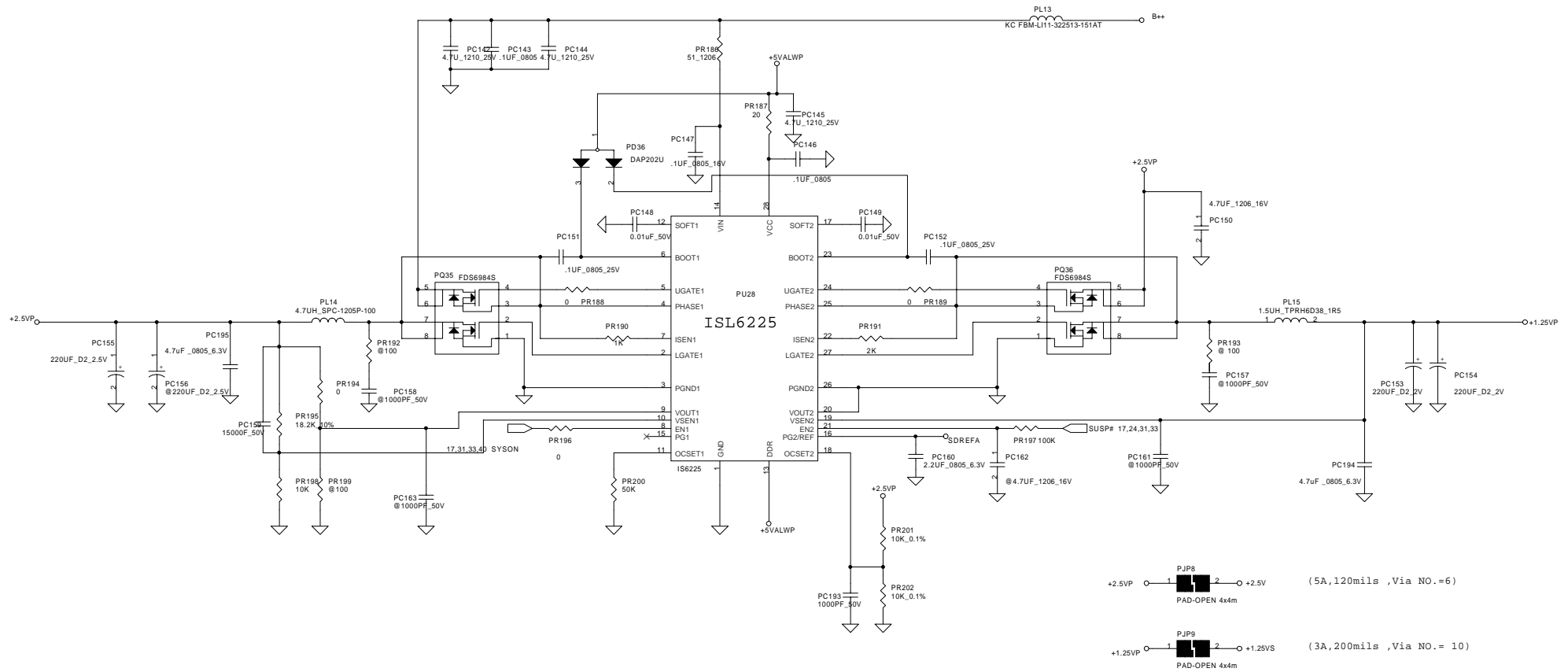

Compal Electronics, Inc.

SCHEMATIC, M/B LA-1391

THIS SHEET OF ENGINEERING DRAWING IS THE PROPRIETARY PROPERTY OF COMPAL ELECTRONICS, INC. AND CONTAINS CONFIDENTIAL AND PROPRIETARY INFORMATION. THIS SHEET MAY NOT BE TRANSFERRED FROM THE CUSTODY OF THE COMPETENT DIVISION OF R&D DEPARTMENT EXCEPT AS AUTHORIZED BY COMPAL ELECTRONICS, INC. NEITHER THIS SHEET NOR THE INFORMATION IT CONTAINS MAY BE USED BY OR DISCLOSED TO ANY THIRD PARTY WITHOUT PRIOR WRITTEN CONSENT OF COMPAL ELECTRONICS, INC.		Size	Document Number	Rev
			401211	1B
Date: 2002.11.26	Sheet 42 of 44			

ATR11 PIR LIST

HW PIR LIST

PWR PIR LIST

ATEST 9/6~			
1	+2.5V LEVEL ERROR	Remove R111 100ohm Change R108 from 100 to 0 ohm	P15
2	SDRAM BANK select error	Change CLK_SDRAM3 from U22.F3 to U22.E3 Change CLK_SDRAM5 from U22.H5 to U22.G5 Change RRAS#3 from U22.H7 to U22.F7 Change RRAS#5 from U22.G6 to U22.H6	P5
3	Add CPU VCCVID pin	Add R492 connect to U23.AF3	P3
4	TV OUT output error	Change CRMA from U8.AF15 to U8.AF16 Change LUMA from U8.AF16 to U8.AF15	P12
5	Add MK1707 output terminate	Add R494 22 ohm	P12
6	Add low pass filter for MK1707 power pin	Add L47	P12
7	Change VGA option resistor to jumper	Change R284 to J3 Change R286 to J4 Change R295 to J5 Change R296 to J6	P15
8	Reserve +2.5V option control	Add R495 for SYSON control Add R496 for SUSP control	P15
9	Change LCD connector type	Change JP1	P16
10	Add TI TPS2042 for USB protect cicuit	Add U56(TPS2042)	P25

BTEST			

THIS SHEET OF ENGINEERING DRAWING IS THE PROPRIETARY PROPERTY OF COMPAL ELECTRONICS, INC. AND CONTAINS CONFIDENTIAL AND TRADE SECRET INFORMATION. THIS SHEET MAY NOT BE TRANSFERRED FROM THE CUSTODY OF THE COMPETENT DIVISION OF R&D DEPARTMENT EXCEPT AS AUTHORIZED BY COMPAL ELECTRONICS, INC. NEITHER THIS SHEET NOR THE INFORMATION IT CONTAINS MAY BE USED BY OR DISCLOSED TO ANY THIRD PARTY WITHOUT PRIOR WRITTEN CONSENT OF COMPAL ELECTRONICS, INC.

Compal Electronics, Inc.			
Title		SCHEMATIC, M/B LA-1391	
Size	Document Number	Rev	
Custom	401211	1B	
Date:	-P期二、十一月26, 2002	Sheet	43 of 44

Version change list (P.I.R. List)

Item	Fixed Issue	Reason for change	Rev.	PG#	Modify List	B.Ver#	Phase
1		Creat +5VP power		36	Add PC192: 0.1UF; PZD5: RLZ5.1B PR208: 10K; PR209: 150K		DVT
2		Meet spec. of ISL6225 DDR2.5V Vsense voltage 0.89V		42	Change PR195 from 17.8K to 18.2K		DVT
3		For CP mode		37	Change PR64 from 10K to 4.7K PC121 from 4700PF to 1000PF		DVT
4		For DDR 1.25V ripple voltage		42	Change PC153, PC154 from 150uF/6.3V to 220uF/2V		DVT
5		For DDR 2.5V voltage		42	Add PC156: 220uF/2V; delete PC155: 220uF/2V		DVT
6		For cost downe		42 40	Change PL15 from 1.5uH SPC_06703 to 1.5UH TPRH6D38 Change PL7 from 5uH SPC_06703 to 5UH TPRH6D38		DVT
7		For DDR 1.25V voltage sense		42	Change PR191 from 6.8K_1% to 2K_1%		DVT
8		For transient response of DDR 2.5V 1.25V		42	Add PC195 PC194 4.7uF/6.3V; de-pop PC153 Change PC193 from 1000pF to 4700pF; PR186 from 10 to 51Ohm		PVT
9		For reduce CP mode noise		37	Change PC121 from 4700PF to 1000PF		PVT
10		Increase voltage margin on CTL of MB1887		37	.De-pop PR100		PVT
11		Change 1.8V to 1.85V P1.5V to 1.73V requested from H/W		40	Change PR62 from 100K to 93.1K PR152 from 43K to 17.8K PR35 from 215K to 249K		PVT

Compal Electronics, Inc.			
Title			
SCHEMATIC, M/B LA-1391			
Size	Document Number		Rev
	401211		1B
Date:	星期三, 十一月 26, 2002		Sheet 44 of 44

PROPRIETARY NOTE THIS SHEET OF ENGINEERING DRAWING IS THE PROPRIETARY PROPERTY OF COMPAL ELECTRONICS, INC. AND CONTAINS CONFIDENTIAL AND TRADE SECRET INFORMATION. THIS SHEET MAY NOT BE TRANSFERRED FROM THE CUSTODY OF THE COMPETENT DIVISION OF R&D DEPARTMENT EXCEPT AS AUTHORIZED BY COMPAL ELECTRONICS, INC. NEITHER THIS SHEET NOR THE INFORMATION IT CONTAINS MAY BE USED BY OR DISCLOSED TO ANY THIRD PARTY WITHOUT PRIOR WRITTEN CONSENT OF COMPAL ELECTRONICS, INC.