

J8 REVISION HISTORY

6/12 EMI Bypass Cap.

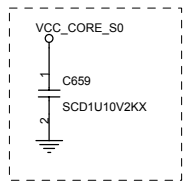
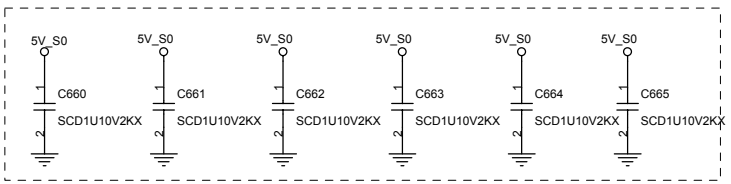
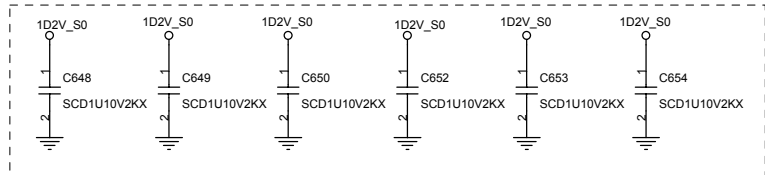
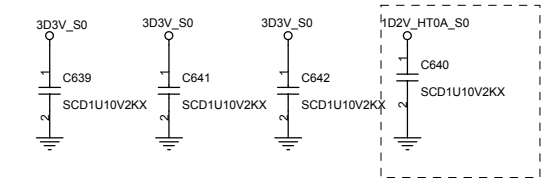
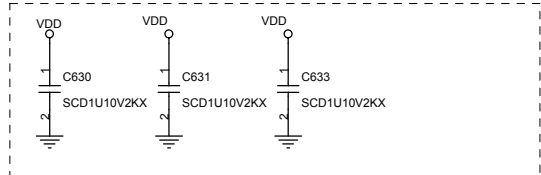
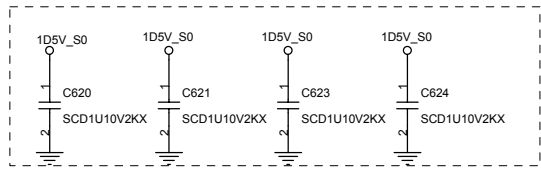
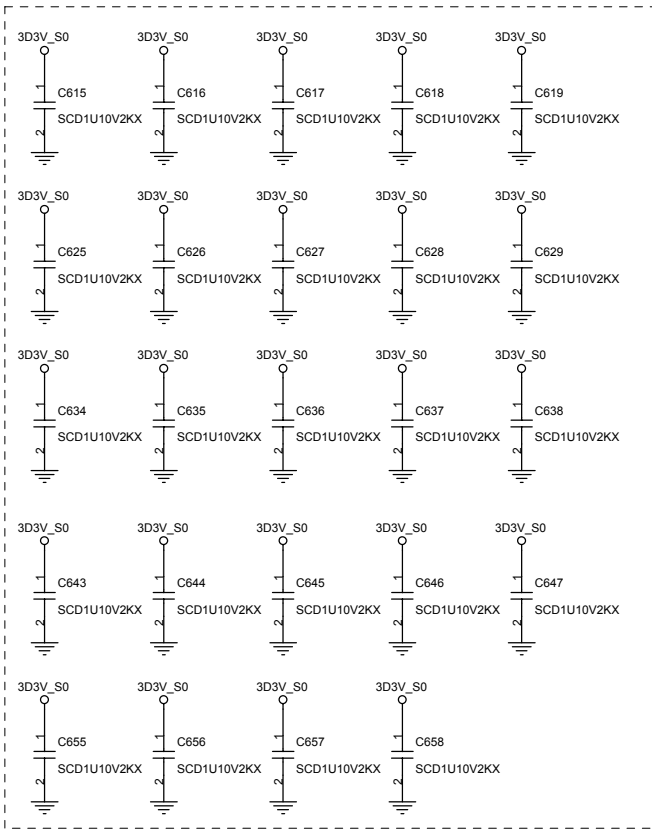

PCI RESOURCE TABLE

DEVICE	IDSEL	PCI IRQ	REQ#/GNT#
Mini-PCI	AD21	P_INTF#	P_REQ#0/P_GNT#0
R5C554-CardBus A	AD22	P_INTB#	P_REQ#1/P_GNT#1
R5C554-CardBus B	AD22	P_INTC#	P_REQ#1/P_GNT#1
R5C554-IEEE 1394	AD22	P_INTD#	P_REQ#1/P_GNT#1
VGA-ATI M10-P		P_INTA#	
BCM-5705M	AD23	P_INTE#	P_REQ#2/P_GNT#2

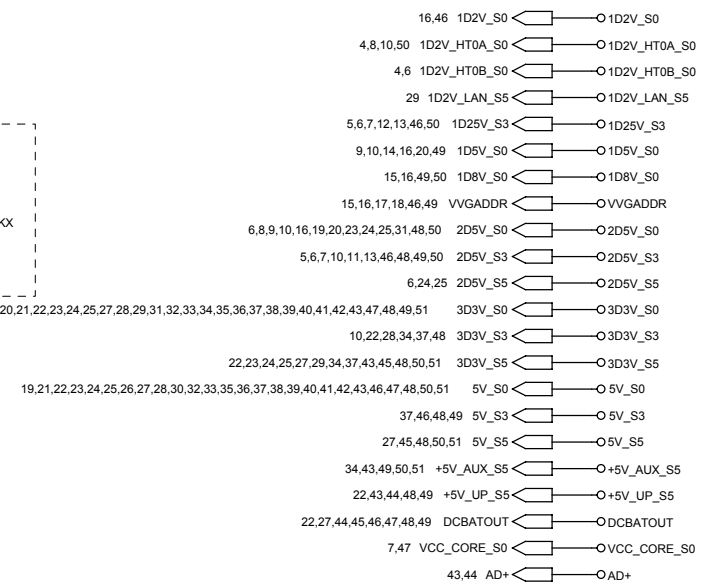

緯創資通 Wistron Corporation
 21F, 88, Sec.1, Hsin Tai Wu Rd., Hsichih,
 Taipei Hsien 221, Taiwan, R.O.C.

Title			REVISION HISTORY		
Size	Document Number				Rev
A3	GANNET				-1
Date:	Thursday, December 04, 2003	Sheet	2	of	51

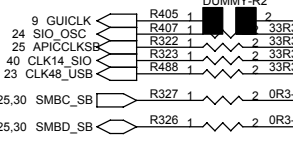
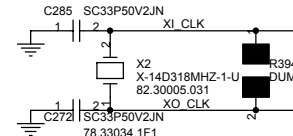
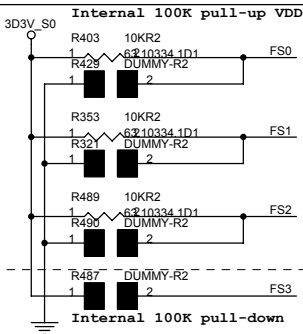
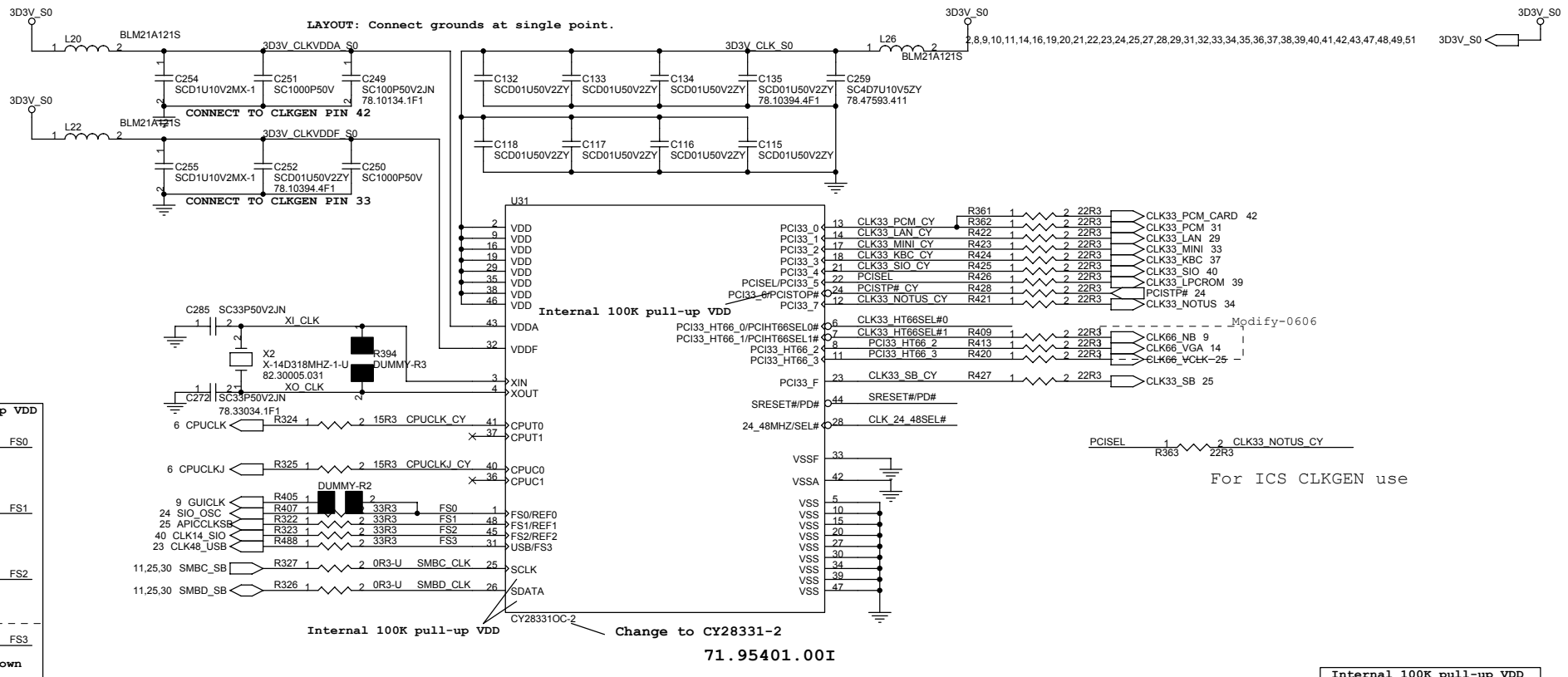

Input Configuration				Clock Generator Output				
FS3	FS2	FS1	FS0	PCI_HT#	CPU (MHz)	PCI33_HT66 (MHz)	PCI33 (MHz)	
0	0	0	0	X	Hi-Z	Hi-Z	Hi-Z	All output Tri-state
0	0	0	1	X	133.9	33.5 or 67.0	33.5	
0	0	1	0	X	166.9	33.4 or 66.8	33.4	
0	0	1	1	X	200.9	33.5 or 67.0	33.5	
0	1	0	0	X	100	33.3 or 66.7	33.3	
0	1	0	1	X	133.33	33.3 or 66.7	33.3	
0	1	1	0	X	166.66	33.3 or 66.7	33.3	
* 0	1	1	1	X	200	33.3 or 66.7	33.3	Normal Hammer operation
1	0	0	0	X	105.0	35.0 or 70.0	35.0	
1	0	0	1	X	110.0	36.7 or 73.3	36.7	
1	0	1	0	X	210.0	35.0 or 70.0	35.0	
1	0	1	1	X	240.0	30.0 or 60.0	30.00	
1	1	0	0	X	270.0	33.8 or 67.5	33.8	
1	1	0	1	X	233.3	27.2 or 58.3	27.2	
1	1	1	0	X	266.7	33.3 or 66.7	33.3	
1	1	1	1	X	300.0	37.5 or 75.0	37.5	

PCISEL	PIN22	24_48 SEL#	24_48MHz
0	PCI33_6	0	48MHz
1	PCISTOP#	1	24MHz

PCIHT66 SEL[1:0]#PCI33_HT66[3:0]					
SEL1	SEL0	PIN6	PIN7	PIN8	PIN11
0	0	HT66	HT66	HT66	HT66
0	1	HT66	HT66	HT66	PCI33
1	0	HT66	HT66	PCI33	PCI33
1	1	HT66	PCI33	PCI33	PCI33

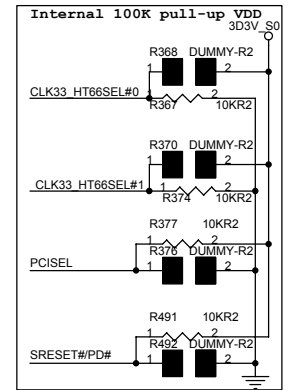

緯創資通 Wistron Corporation
21F, 88, Sec.1, Hsin Tai Wj Rd., Hsichih, Taipei Hsien 221, Taiwan, R.O.C.

Title: **CLKGEN_CY28331**

Size: A3 Document Number: **Gannet** Rev: -1

Date: Thursday, December 04, 2003 Sheet: 3 of 51

Clawhammer HT Interface

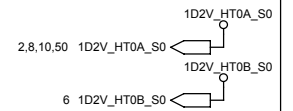

LAYOUT: Close to CPU within 1 inch
#24665 PG:135

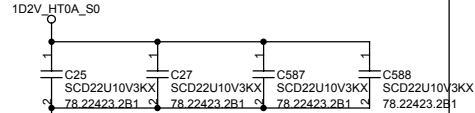

Between CPU and NB

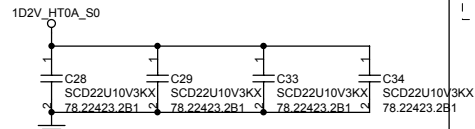

11/11 add SCD22U
For AMD suggest.

HTT for CPU sideA
Transmit power
and NB sideA Receive
power

HTT for CPU sideB
Receive power
and NB sideA
Transmit power

LAYOUT: Place bypass cap on topside of board near
HTT power pins that are not connected directly to
downstream HTT device, but connected internally to
other HTT power pins.

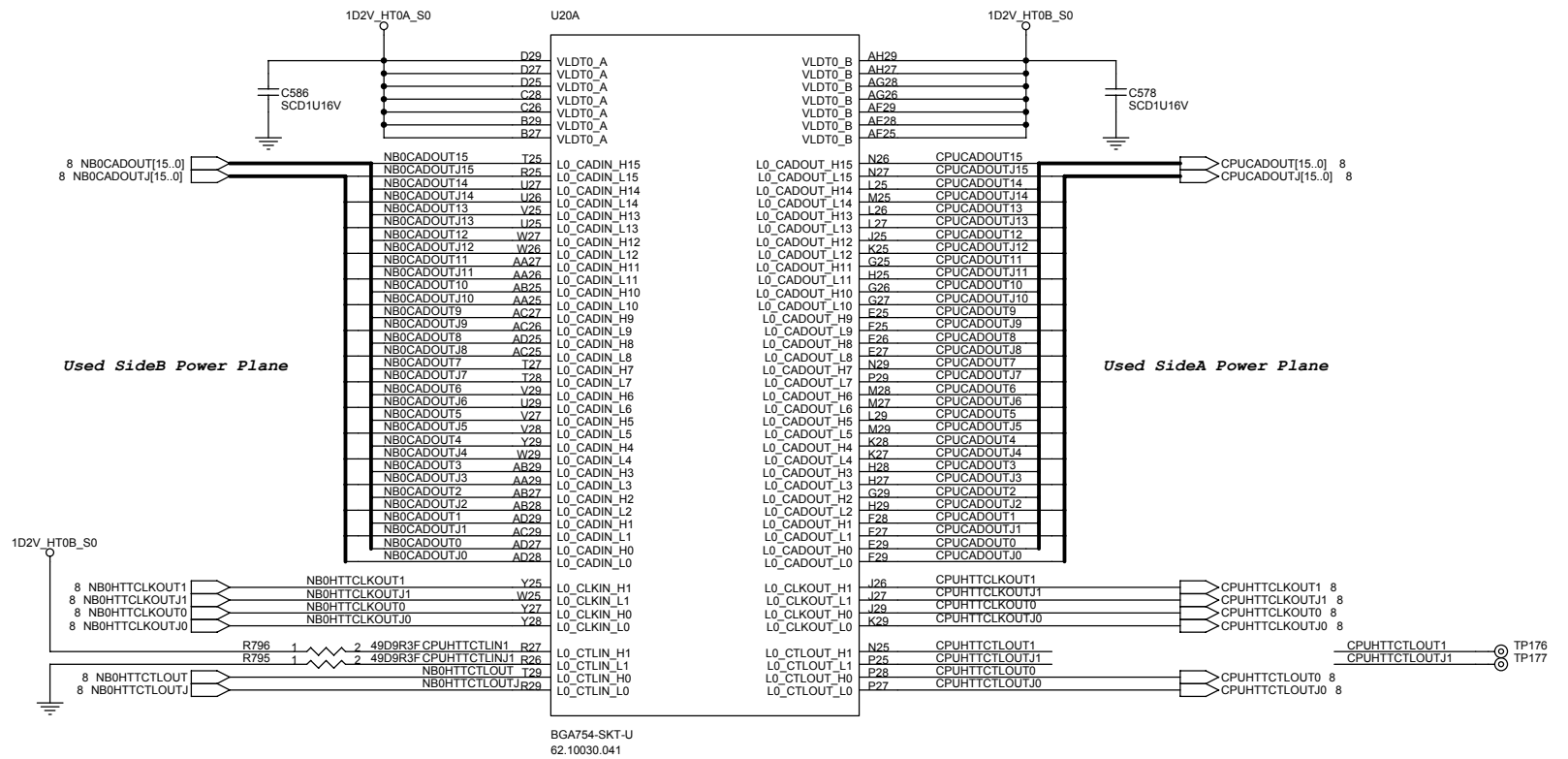
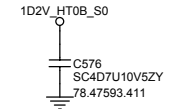

BGA754-SKT-U
62.10030.041

緯創資通 Wistron Corporation
21F, 88, Sec. 1, Hsin Tai Wd Rd., Hsichih,
Taipet Hsien 221, Taiwan, R.O.C.

Title			
CPU(1/4)_HyperTransport I/F			
Size	Document Number	Rev	
A3	Gannet	-1	
Date: Thursday, December 04, 2003			
Sheet		4	of
		51	

Clawhammer DDR Interface

VREF_DDR_MEM

NOTE: Test with passive probes only.
NOTE: Install to bypass op-amp

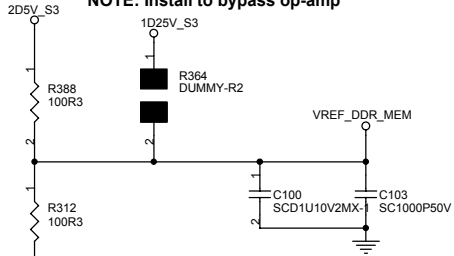

LAYOUT: Locate close to DIMMs.

NOTE: Remove to bypass op-amp

VREF_DDR_CLAW

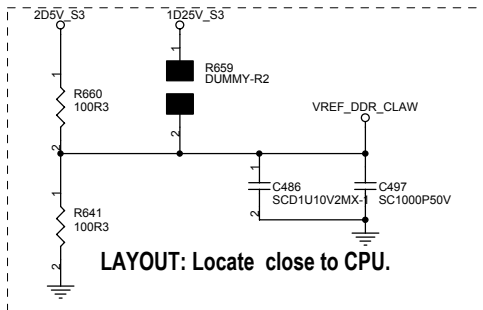

LAYOUT: Locate close to CPU.

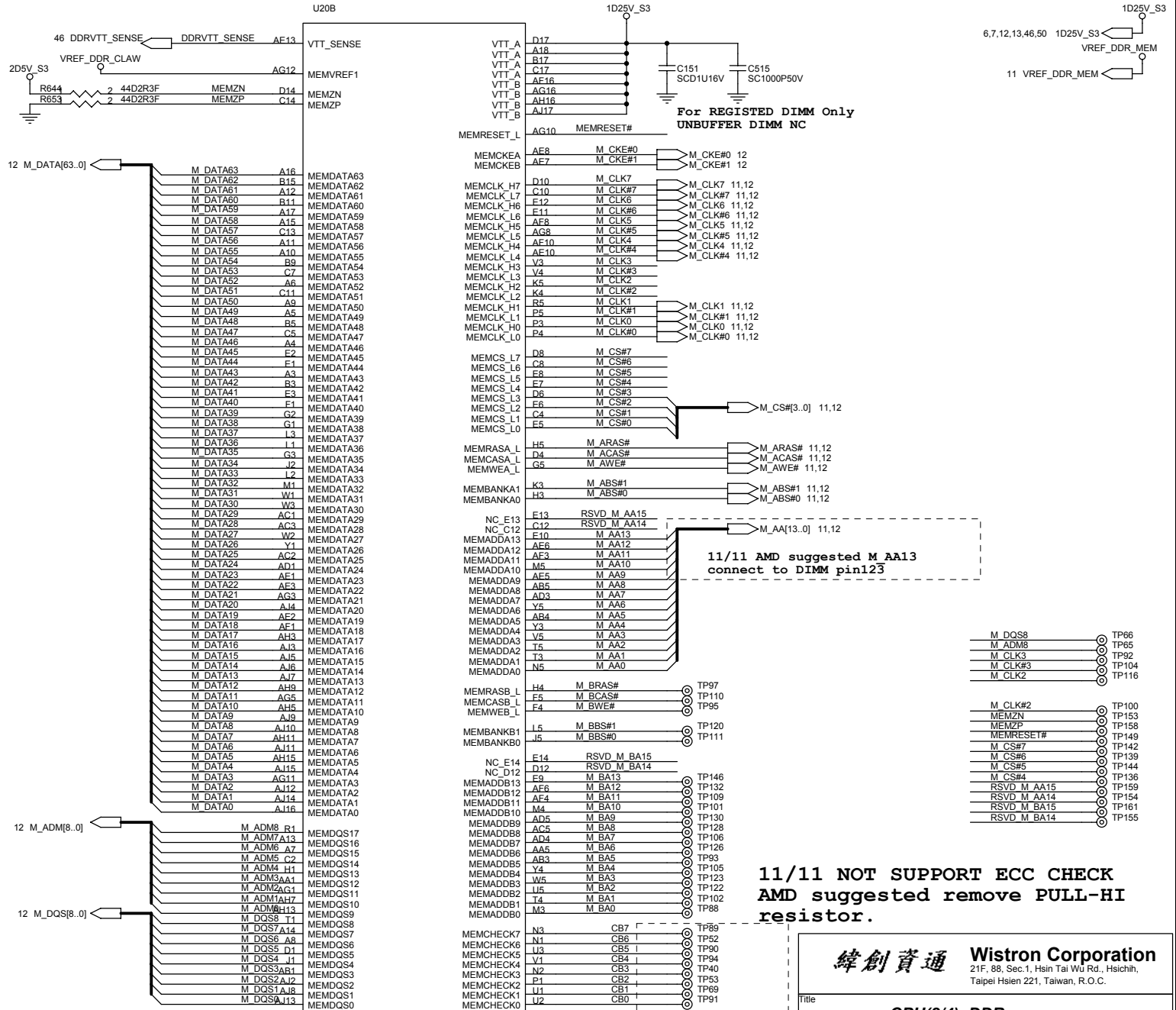

緯創資通 Wistron Corporation
21F, 88, Sec.1, Hsin Tai Wu Rd., Hsichih, Taipei Hsien 221, Taiwan, R.O.C.

Title CPU(2/4)_DDR

Size A3 Document Number Gannet Rev -1

Date: Thursday, December 04, 2003 Sheet 5 of 51

Clawhammer Control and Debug

2D5V_VDDA_S0

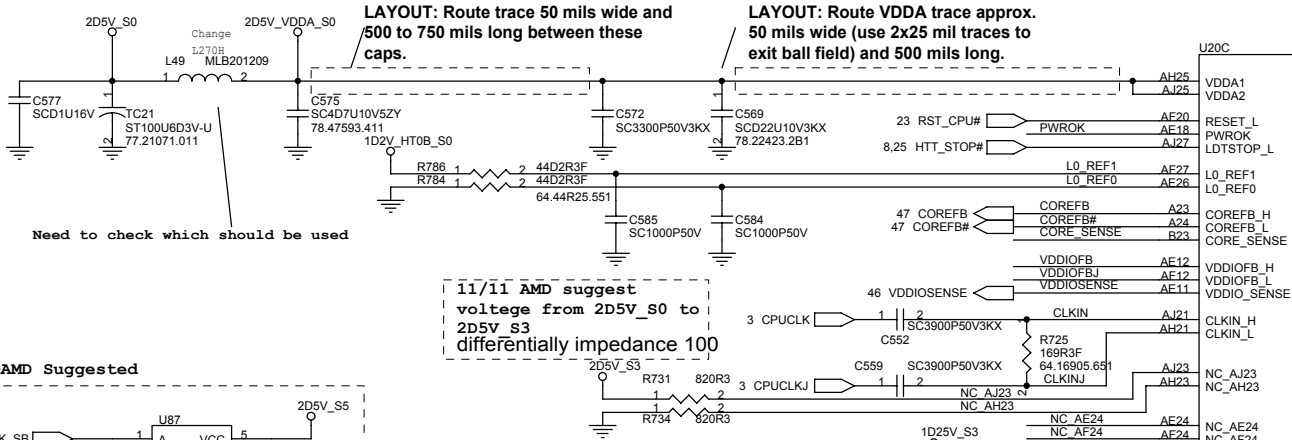

5/12-->AMD Suggested

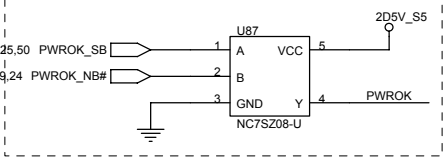

HDT Connectors

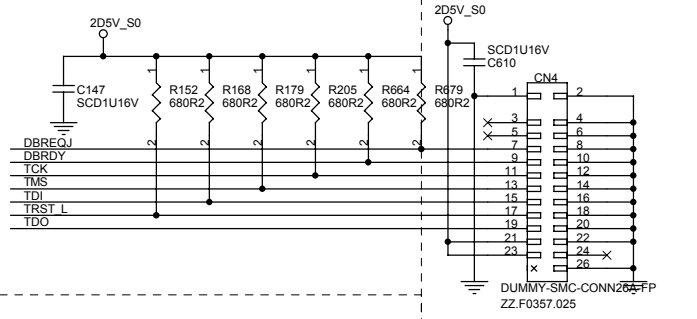

10/22 CHANGE FROM 1KR3 TO 680R2 FOR AMD CHECK LIST

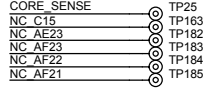
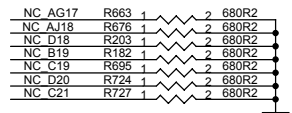

Validation Test Points

LAYOUT: Place close to the CPU.

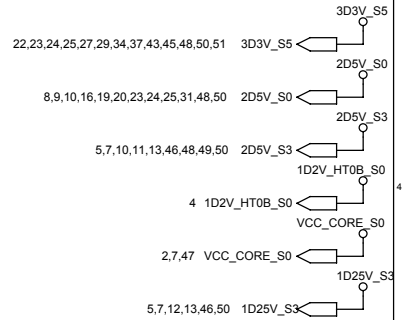
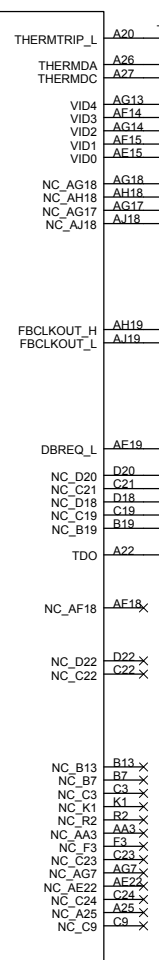
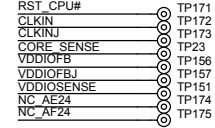

LAYOUT: Route FBCLKOUT_H/L differentially impedance 80

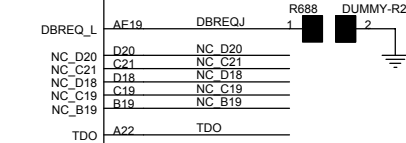
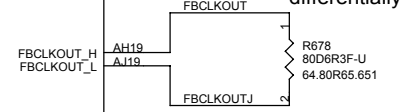

10/22 CHANGE VCC FROM 2D5V_S3 TO 2D5V_S0

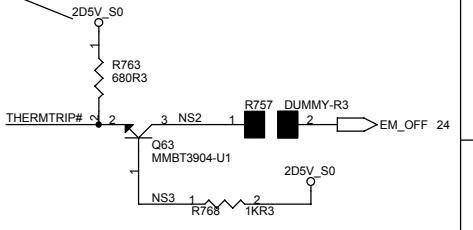

THERMTRIPJ Level shift to VT8235 EM_OFF PIN near VT8235

緯創資通 Wistron Corporation
 21F, 88, Sec.1, Hsin Tai Wj Rd., Hsichih, Taipei Hsien 221, Taiwan, R.O.C.

Title: **CPU(3/4)_Control & Debug**

Size: A3 Document Number: **Gannet** Rev: -1

Date: Thursday, December 04, 2003 Sheet: 6 of 51

Clawhammer Power and Ground Connections

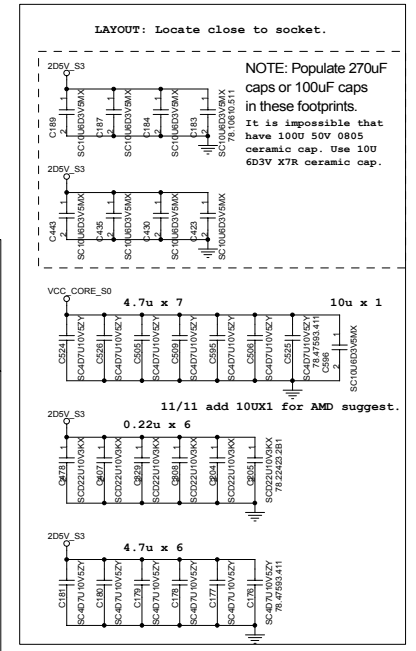
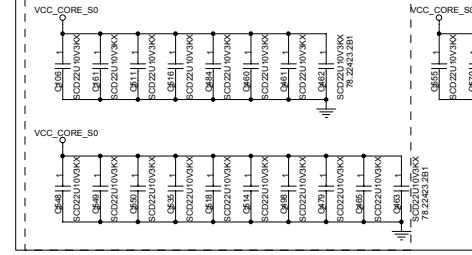
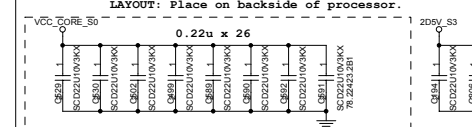
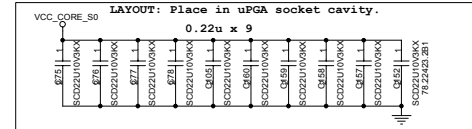
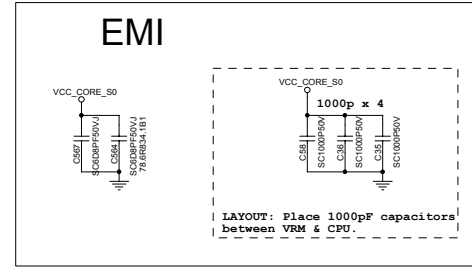
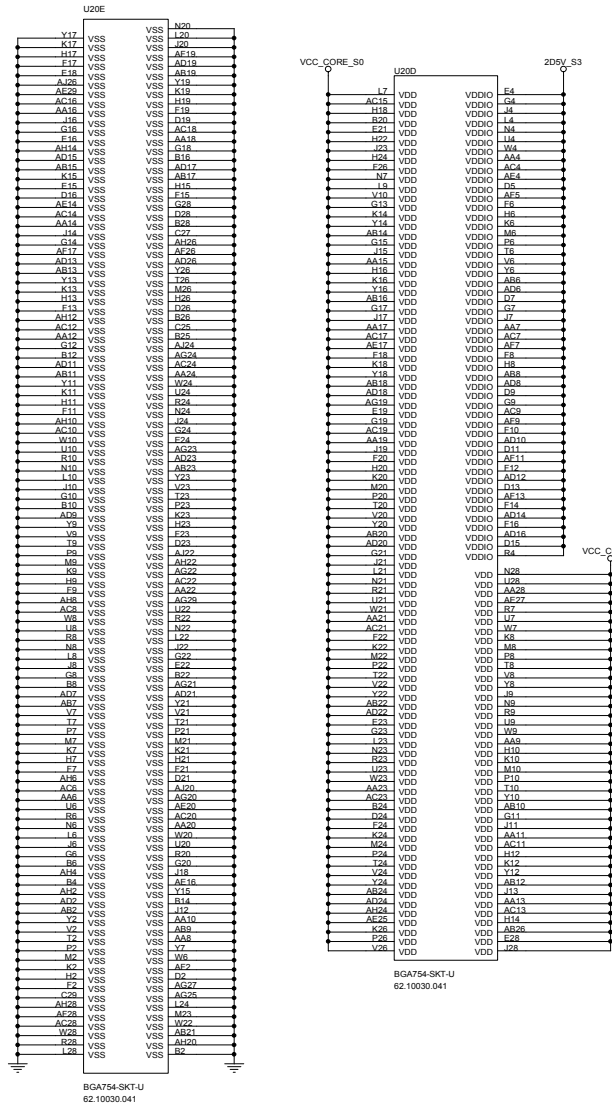

CLAW HAMMER TO NB

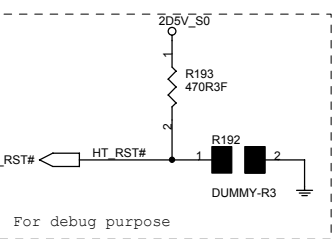
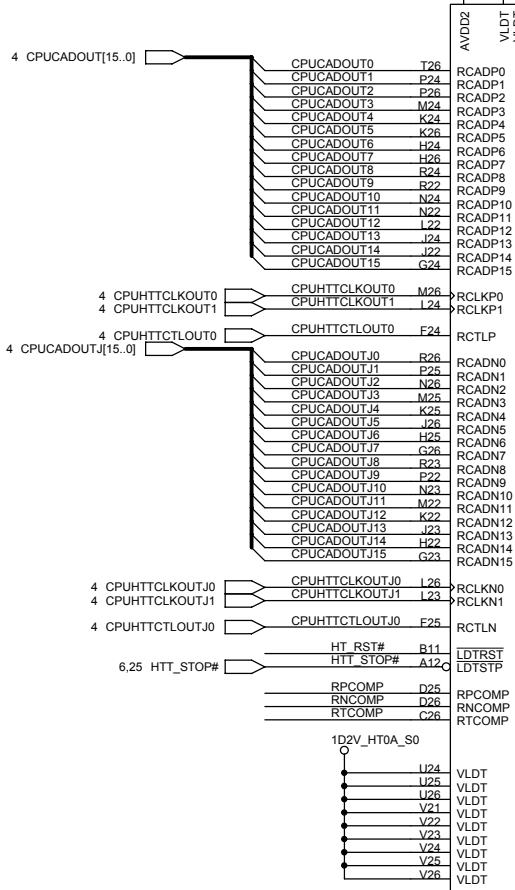

NB TO CLAW HAMMER

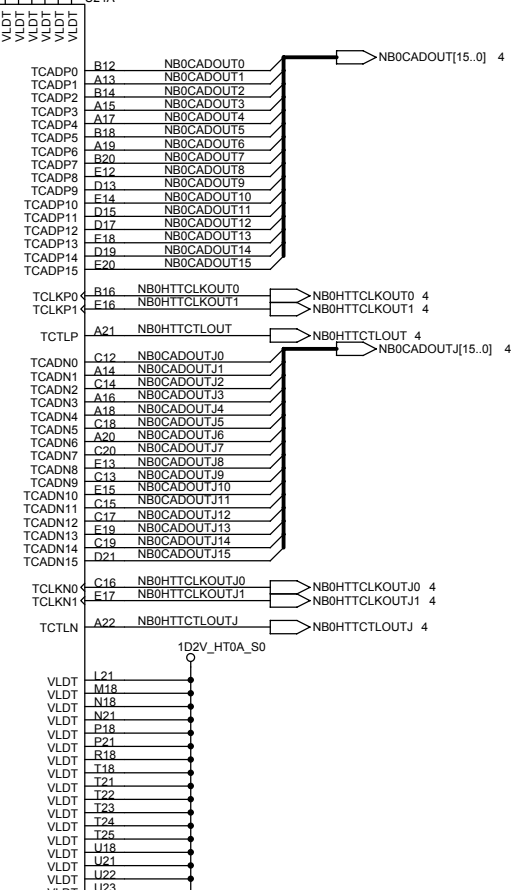

K8M400-VD7
71.K8T00.00U

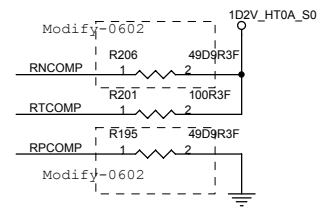
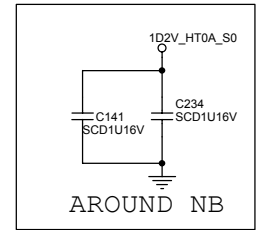
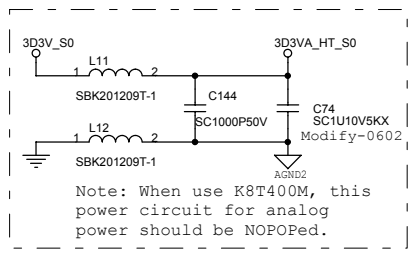
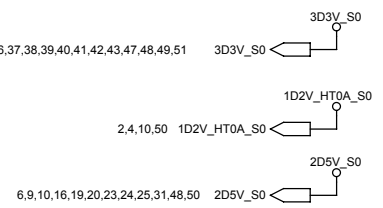

緯創資通 Wistron Corporation
21F, 88, Sec. 1, Hsin Tai Wj Rd., Hsichih, Taipei Hsien 221, Taiwan, R.O.C.

Title: **NB-K8T800M(1/3)_HT**

Size: A3	Document Number: Gannet	Rev: -1
----------	-------------------------	---------

Date: Thursday, December 04, 2003 Sheet: 8 of 51

25 VLAD[7..0]

VLAD0 AD20
VLAD1 AD21
VLAD2 AD22
VLAD3 AF24
VLAD4 AE18
VLAD5 AF20
VLAD6 AD24
VLAD7 AF25

25 VBE# VBE# AE21
25 LPAR LPAR AF19

25 UPSTB UPSTB AF23
25 UPSTB# UPSTB# AF23

25 DNSTB DNSTB AF22
25 DNSTB# DNSTB# AD22

25 UPCMD UPCMD AF26
25 DNCMD DNCMD AD23

VL_VREF AF21
LVREF

6,24 PWROK_NB# AE26
PWRGD

23 RST_NB# AC25
PCIRST

14,24 PM_SUS_STAT# AC26
TESTIN

DEBUG AC17
SUSTAT

CRT_A/R B3
CRT_A/G A3
CRT_A/B A2

CRT_RSET C4
CRT_HSYNC A1
CRT_VSYNC B1

AR/NC
AG/NC
AB/NC

RSET/NC
HSYNC/NC
VSYNC/NC

XIN/NC
INTA/NC
BIST/NC

SPCLK1/NC P2
SPCLK2/NC C2
SPD1/NC P1
SPD2/NC C1

DPO_D0 J1
DPO_D1 K2
DPO_D2 K3
DPO_D3 L4
DPO_D4 K1
DPO_D5 L2
DPO_D6 L3
DPO_D7 M4
DPO_D8 L1
DPO_D9 M2
DPO_D10 M3
DPO_D11 M1

DPO_DET B4
DPO_HSYNC N1
DPO_VSYNC N4
TVCLK/DPVDET/NC N1
TVDE/DPVDE/NC N4
TVHS/DPVHS/NC N3
TVVS/DPVVS/NC N3

TVCLK/DPVDC/NC
TVCLK/DPVDC/NC

GPO0/NC
GPO1/NC

DUMMY-0R3-U Modify-0602

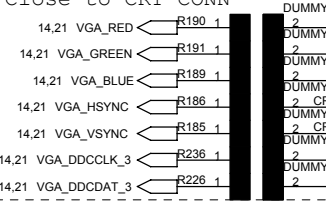

V_LINK

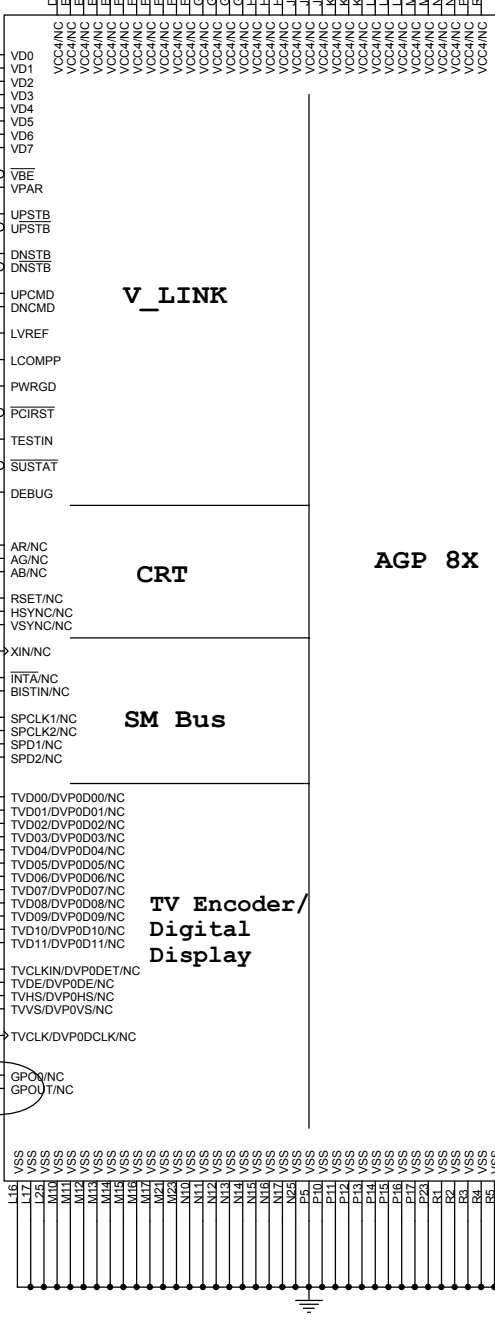

AGP 8X

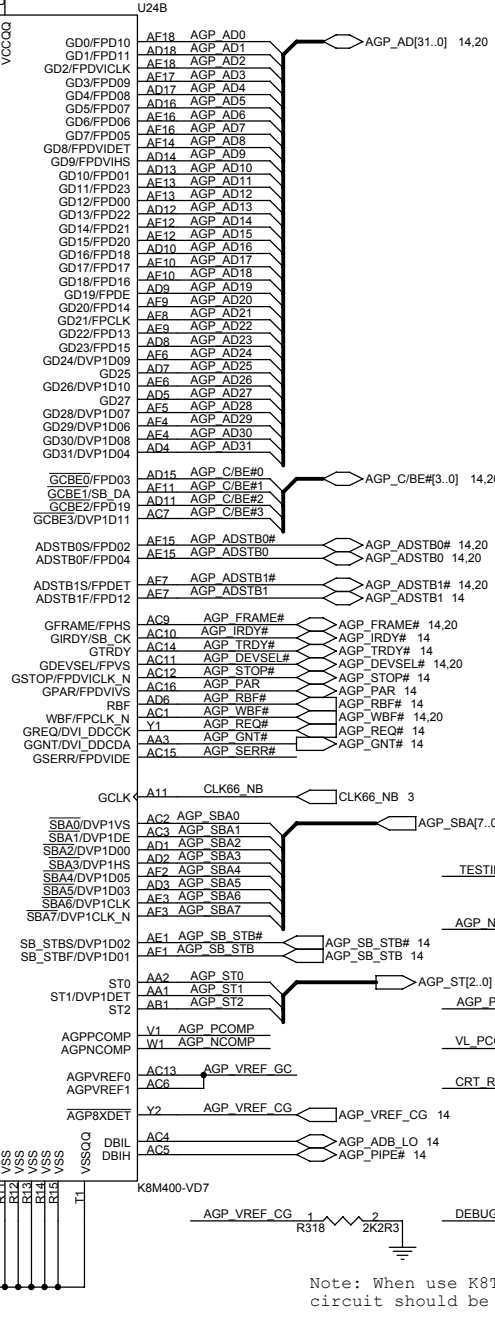

SM Bus

TV Encoder/ Digital Display

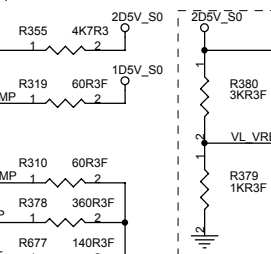
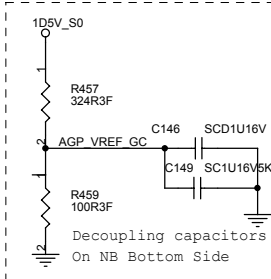
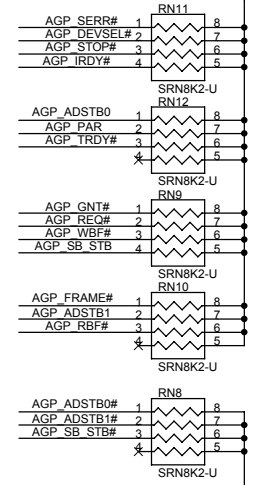

Layout trace 20 mil
The voltage level of
VL_VREF is 0.625V
Cross NB as short as possible

Use this function for K8M400

AGP power up strapping setting:
TV0/DPV0D[3:0] => Panel type selection
TV04/DPV0D4 => FP-port multiplexed on AGP interface selection
0: Two 12-bit DVI interface
1: One 24-bit panel interface
TV05/DPV0D5 => Dedicated DVI port configuration
0: DMS
1: TV Encoder
TV06/DPV0D6 => Dedicated DVI port selection
0: Disable
1: Enable

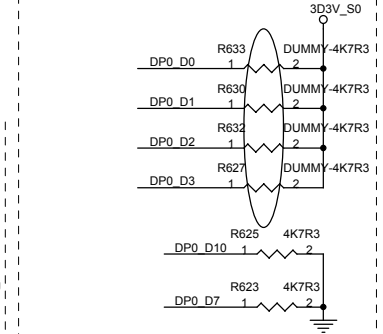
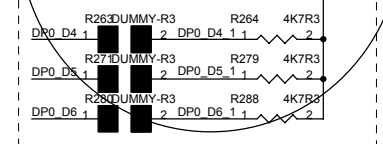

Note: All of these power up strapping pin have internal pull down. Put an external pull up resistor if want to set the default value to 1.

緯創資通 Wistron Corporation
21F, 88, Sec.1, Hsin Tai Wu Rd., Hsichih, Taipei Hsien 221, Taiwan, R.O.C.

Title		NB-K8T800M(2/3) AGP VLINK	
Size	A3	Document Number	Gannet
Date:	Thursday, December 04, 2003	Sheet	9 of 51

Note: When use K8T400M, GFX relative circuit should be NOPOped.

Layout trace 20 mil

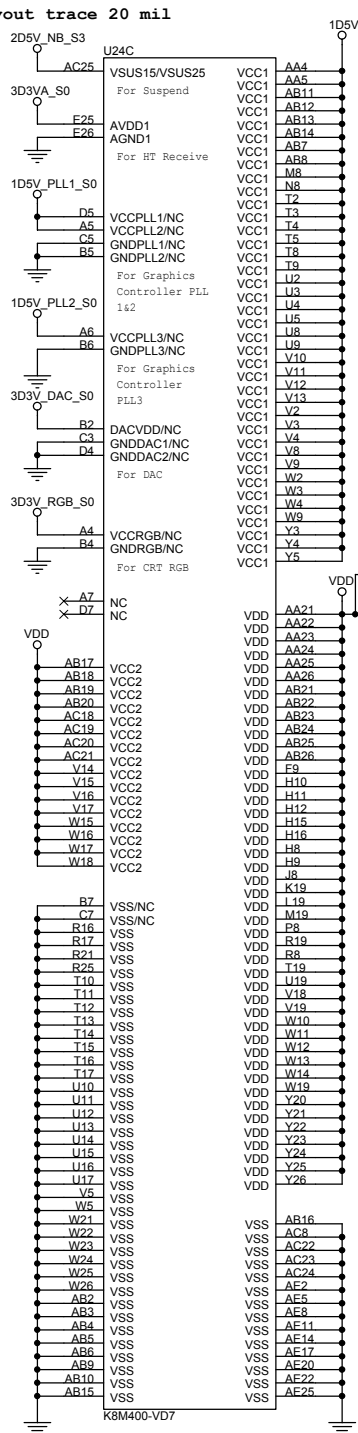

Layout trace 20 mil

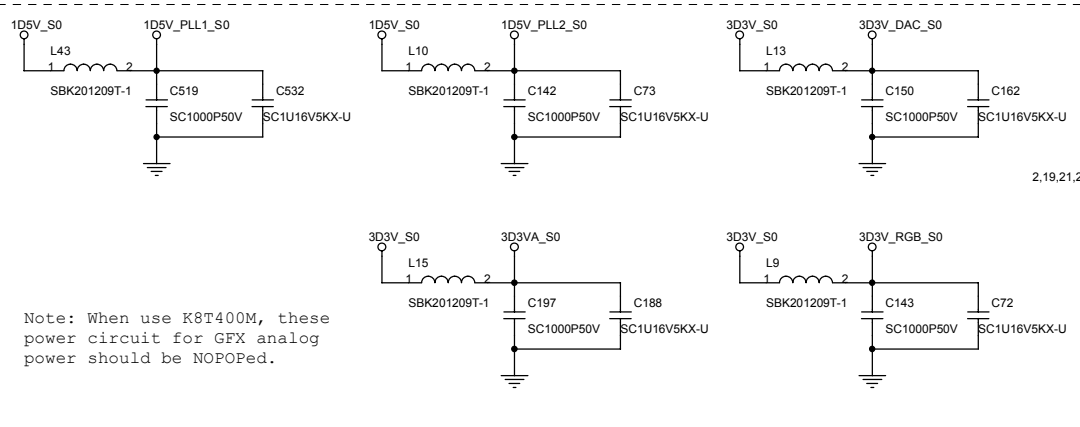

Note: When use K8T400M, these power circuit for GFX analog power should be NOPOPed.

NEAR N/B ON BOT SIDE

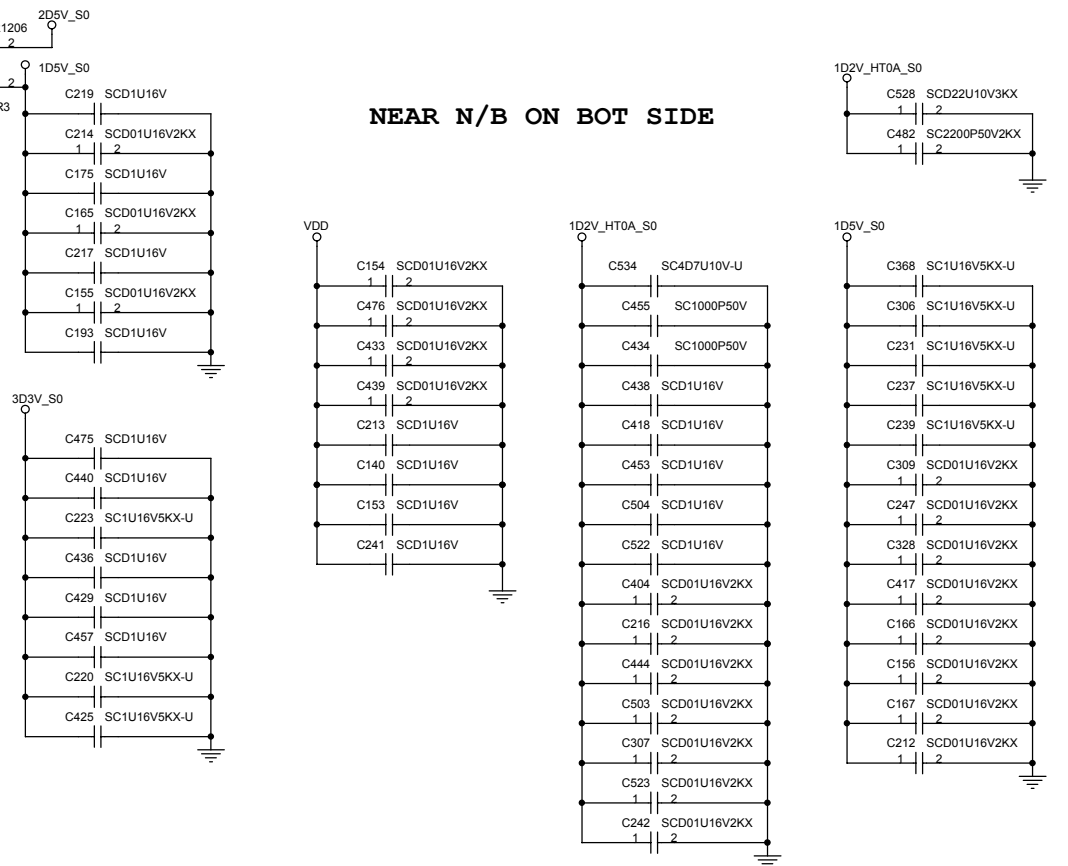

2,3,8,9,11,14,16,19,20,21,22,23,24,25,27,28,29,31,32,33,34,35,36,37,38,39,40,41,42,43,47,48,49,51

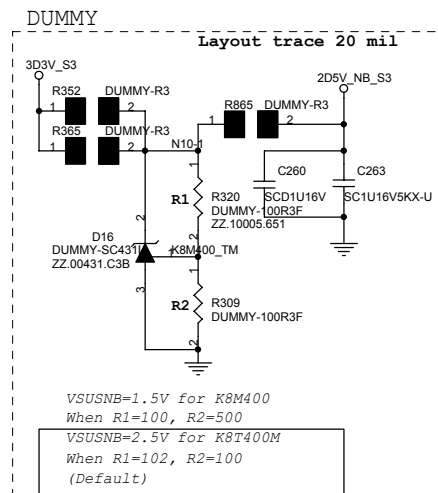
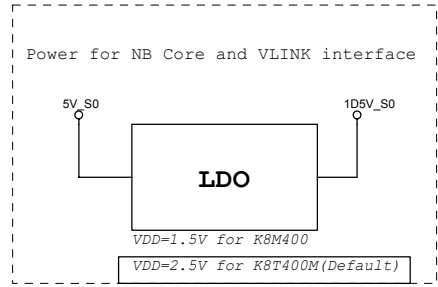
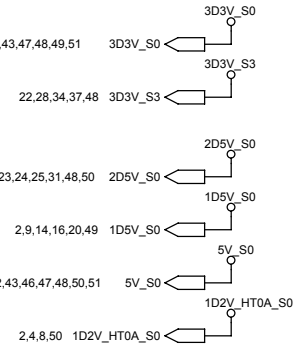

緯創資通 Wistron Corporation
 21F, 88, Sec.1, Hsin Tai Wu Rd., Hsichih, Taipei Hsien 221, Taiwan, R.O.C.

Title: **NB-K8T800M(3/3) POWER**

Size: A3 Document Number: **Gannet** Rev: -1

Date: Thursday, December 04, 2003 Sheet 10 of 51

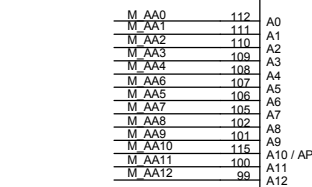

NORMAL TYPE

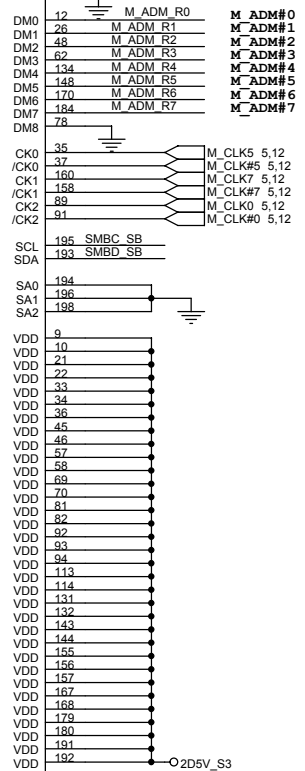
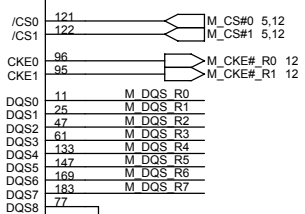

NOT SUPPORT ECC CHECK
Ali suggested pull-low

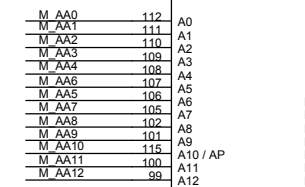
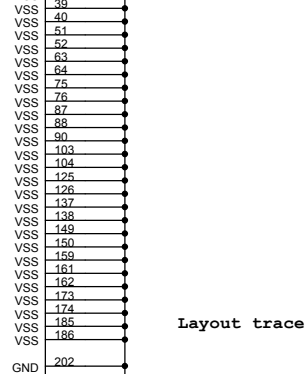

REVERSE TYPE

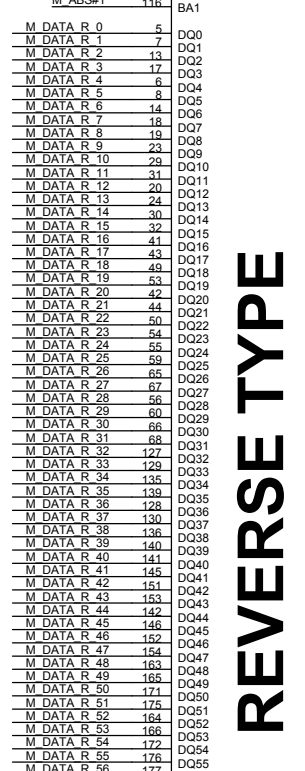

NOT SUPPORT ECC CHECK
Ali suggested pull-low

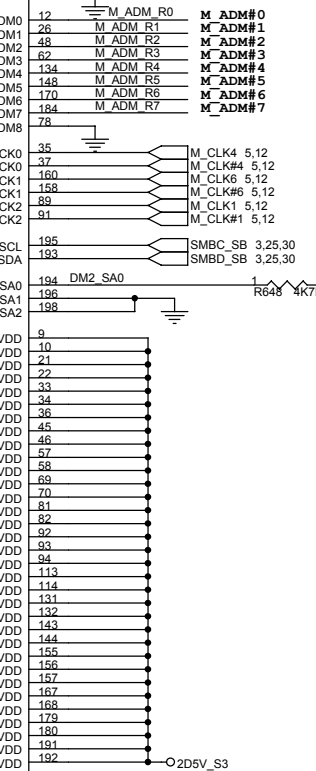
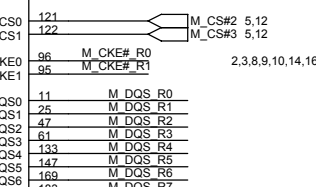
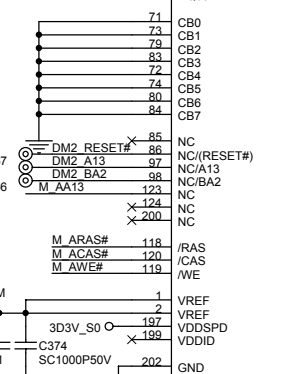

NOT SUPPORT ECC CHECK
Ali suggested pull-low

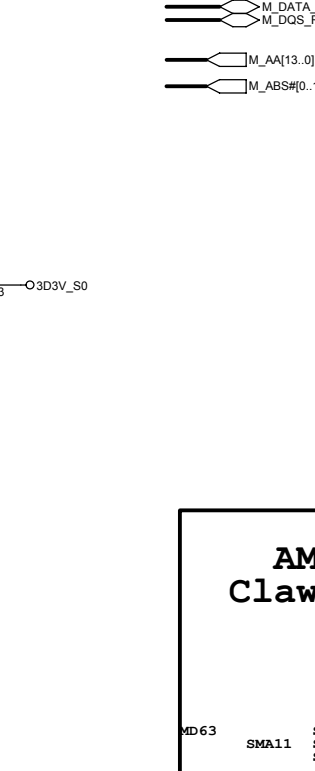
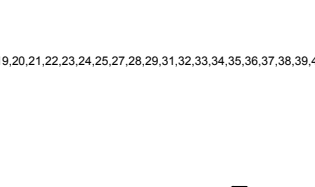
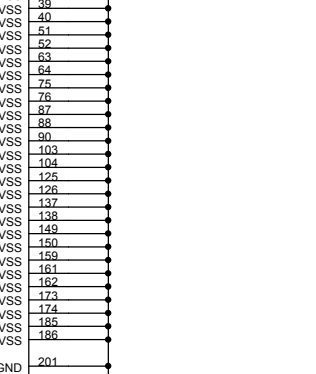

NOT SUPPORT ECC CHECK
Ali suggested pull-low

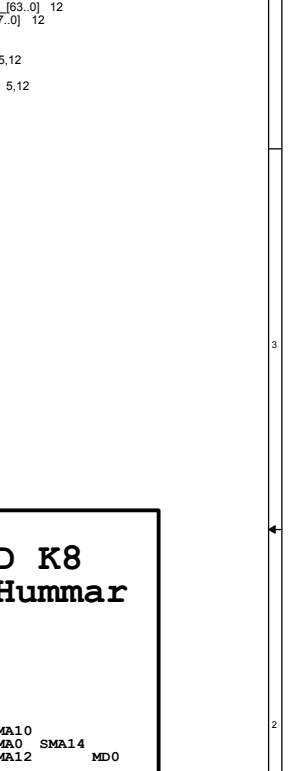
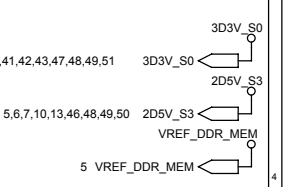
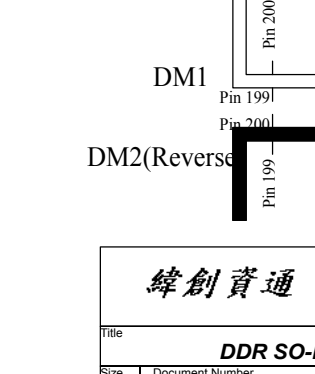

NOT SUPPORT ECC CHECK
Ali suggested pull-low

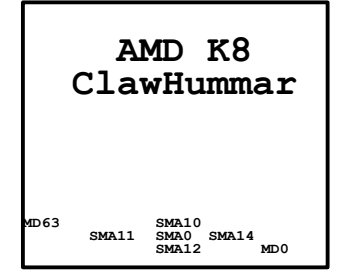
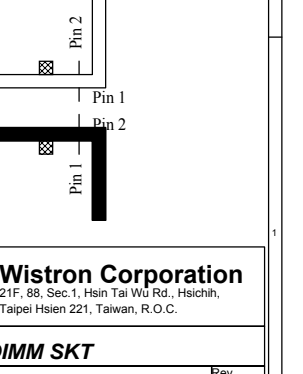

**DDR SOCKET PLACEMENT
TOP VIEW PERSPECTIVE DRAWING**

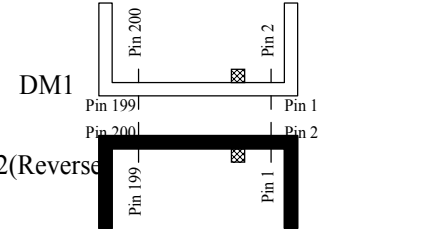

緯創資通 Wistron Corporation
21F, 88, Sec.1, Hsin Tai Wj Rd., Hsichih, Taipei Hsien 221, Taiwan, R.O.C.

Title: **DDR SO-DIMM SKT**

Size A3	Document Number	Rev -1
Gannet		

Date: Thursday, December 04, 2003 Sheet 11 of 51

SERIES DAMPING

PLACE RNs CLOSE TO FIRST DM (DM2), < 0.75"
STRICT EQUAL LENGTH LIMITATION WITH DQS,
CB PINS

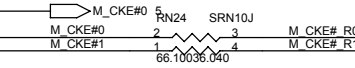
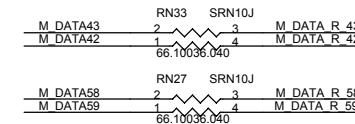
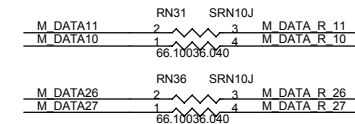
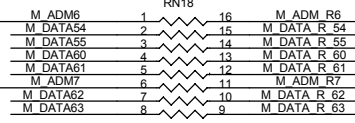
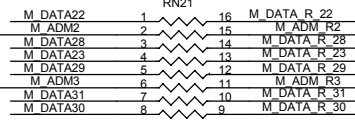
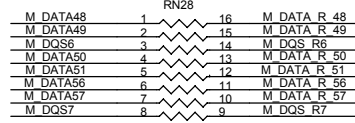
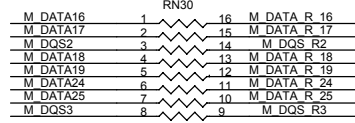
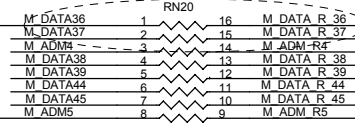
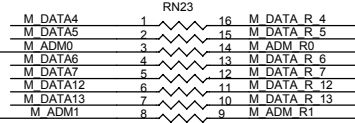
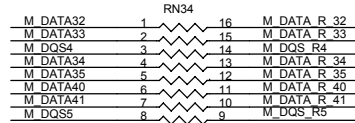
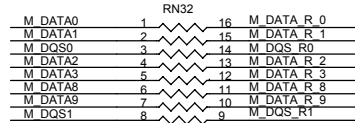

11/11 add RN30 for AMD suggest.

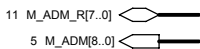
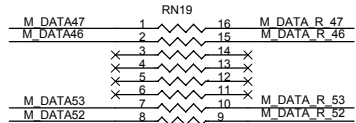
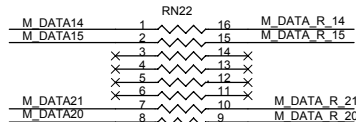

TERMINATION

PULL HIGH STUBS < 0.8", PLACE RPs CLOSE TO SECOND DM (DM1)
NO EQUAL LENGTH LIMITATION

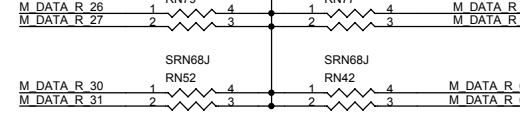
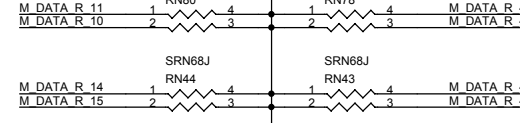
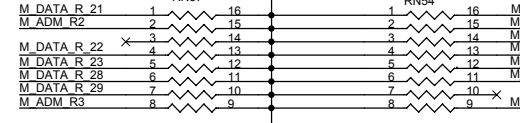
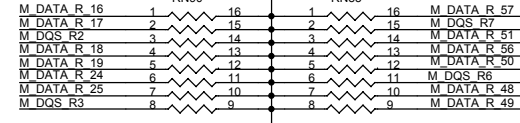
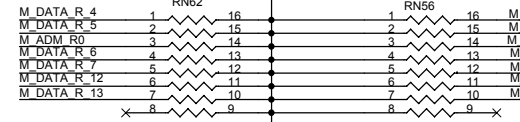
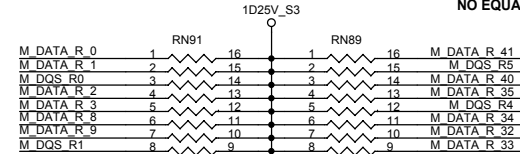

PLACE BETWEEN DM1, DM2
CLOSE TO FIRST DM (DM 2) < 0.2", TO SECOND DM (DM1) < 1.1"
EQUAL LENGTH LIMITATION WITH SCK/SCK#

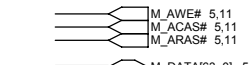
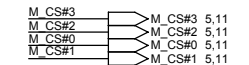
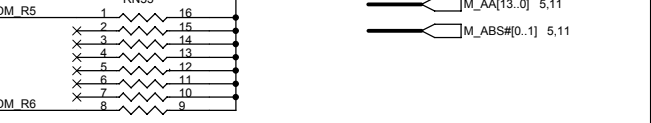
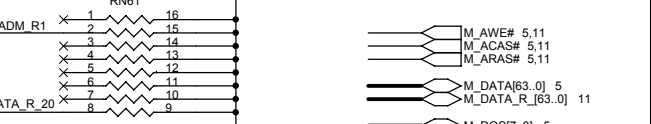
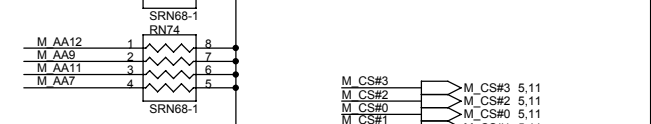
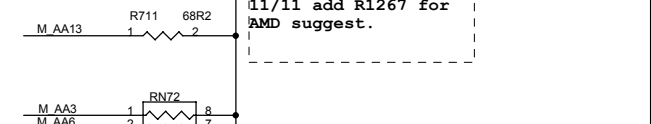
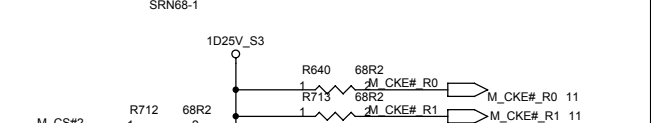
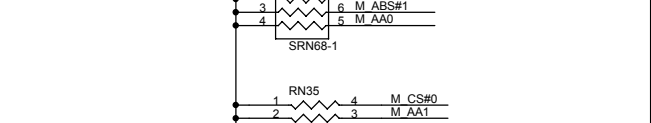
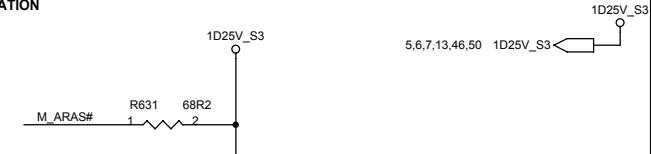
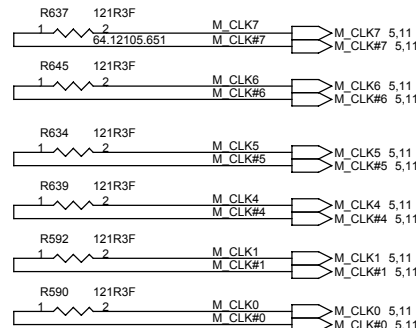

緯創資通 Wistron Corporation
21F, 88, Sec.1, Hsin Tai Wj Rd., Hsichih,
Taipet Hsien 221, Taiwan, R.O.C.

1D25V_S3 TO GND	100u	10u	4.7u	0.22u	0.1u	1000p	100p
	2	2	10	10	34	4	4

1D25V_S3 TO 2D5V_S3	220u	0.22u	0.1u
	1	10	34



LAYOUT: Place alternating caps to GND and 2D5_DRAM

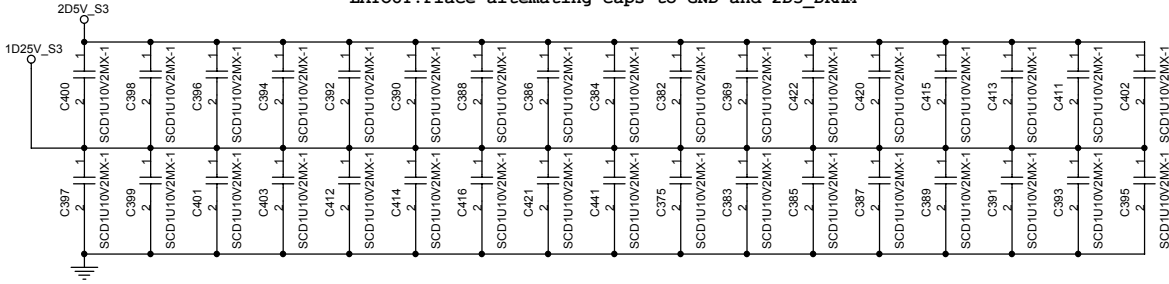

LAYOUT: Add 100pF and 1000pF on VTT fill near Clawhammer and near DIMMs (both sides).

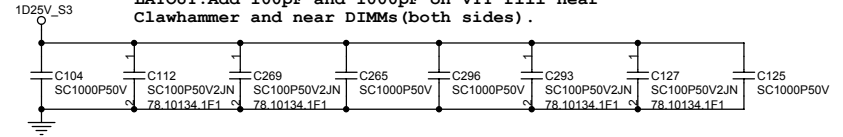

LAYOUT: Place one 10uF capacitor on each end of the VTT island.

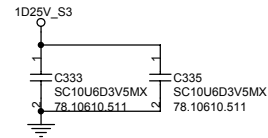

LAYOUT: Locate close to Clawhammer socket.

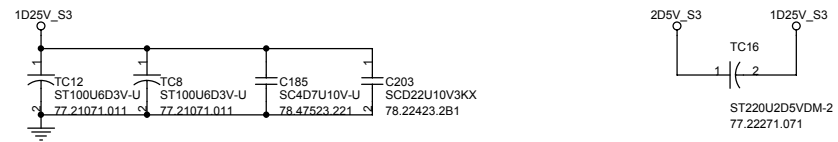

LAYOUT: Place a cap every 1 in. on VTT traces between Clawhammer and DDR.

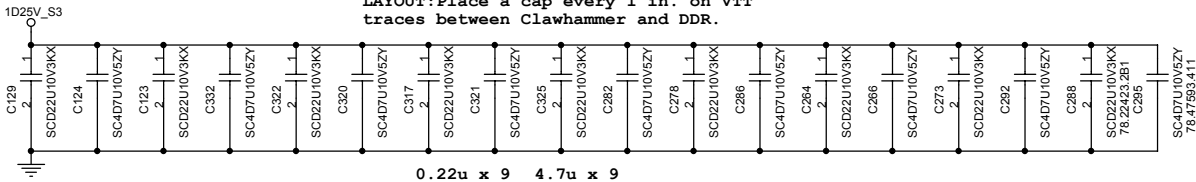

LAYOUT: Place on backside, evenly spaced around VTT fill.

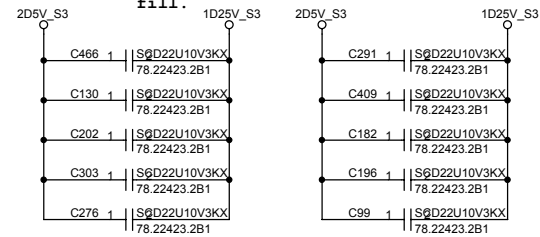

緯創資通 Wistron Corporation
21F, 88, Sec. 1, Hsin Tai WJ Rd., Hsichih,
Taipei Hsien 221, Taiwan, R.O.C.

Title			DDR DECOUPLING		
Size	Document Number	Gannet		Rev	-1
A3					
Date: Thursday, December 04, 2003			Sheet	13	of 51

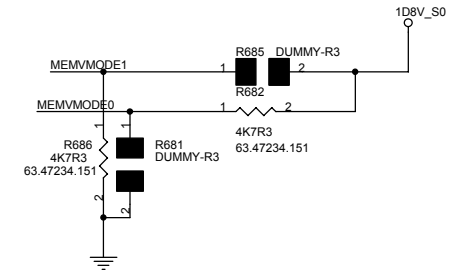
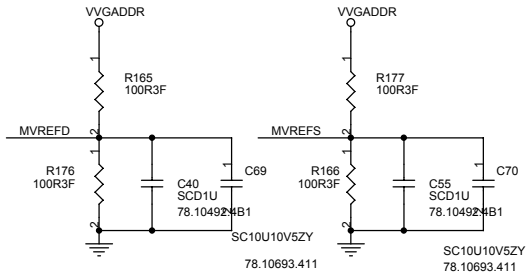
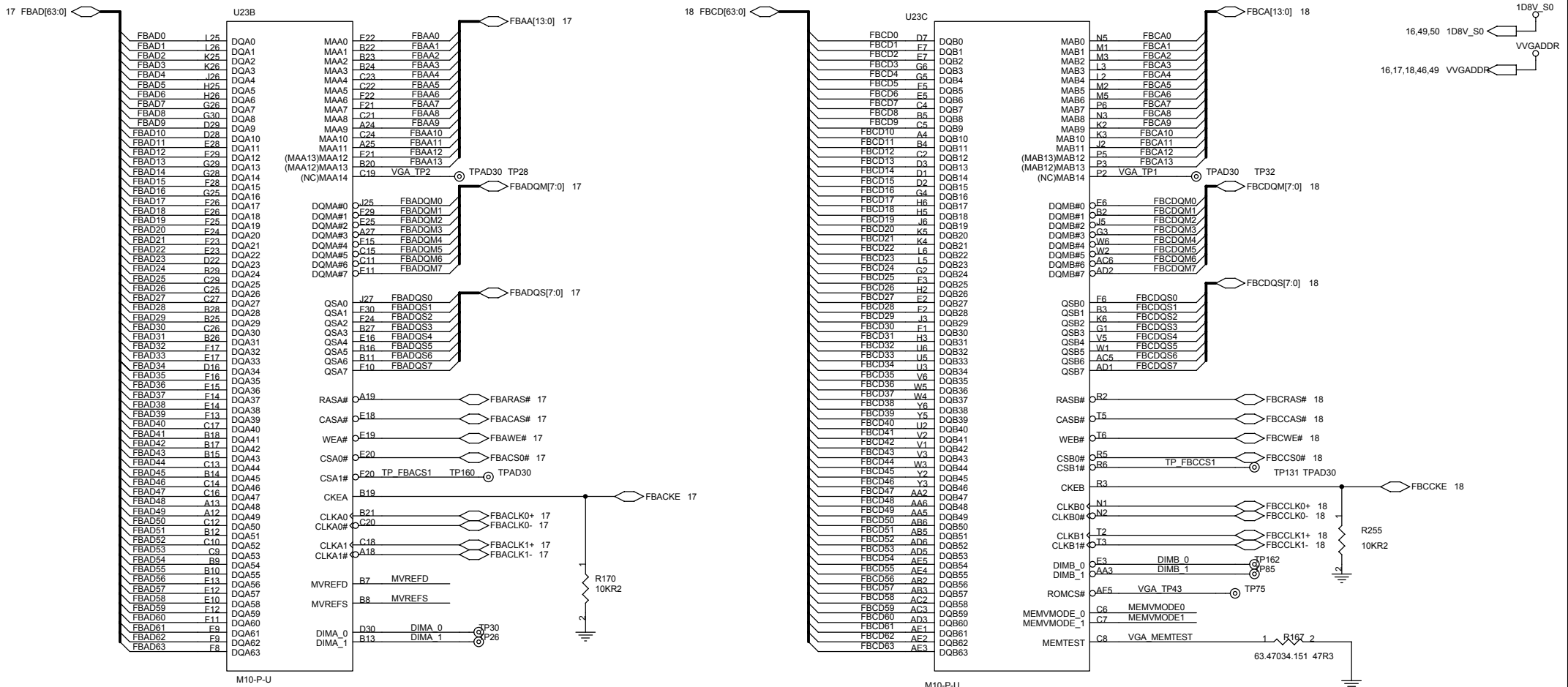

	MEMMODE0	MEMMODE1
2D5V VDDR1	1	0
1D8V VDDR1 (ELPIDA)	0	1

緯創資通 Wistron Corporation
 21F, 88, Sec.1, Hsin Tai Wj Rd., Hsichih, Taipei Hsien 221, Taiwan, R.O.C.

Title: **VGA(2/3) ATI M10-P MEM**

Size: A3 Document Number: Gannet Rev: -1

Date: Thursday, December 04, 2003 Sheet: 15 of 51

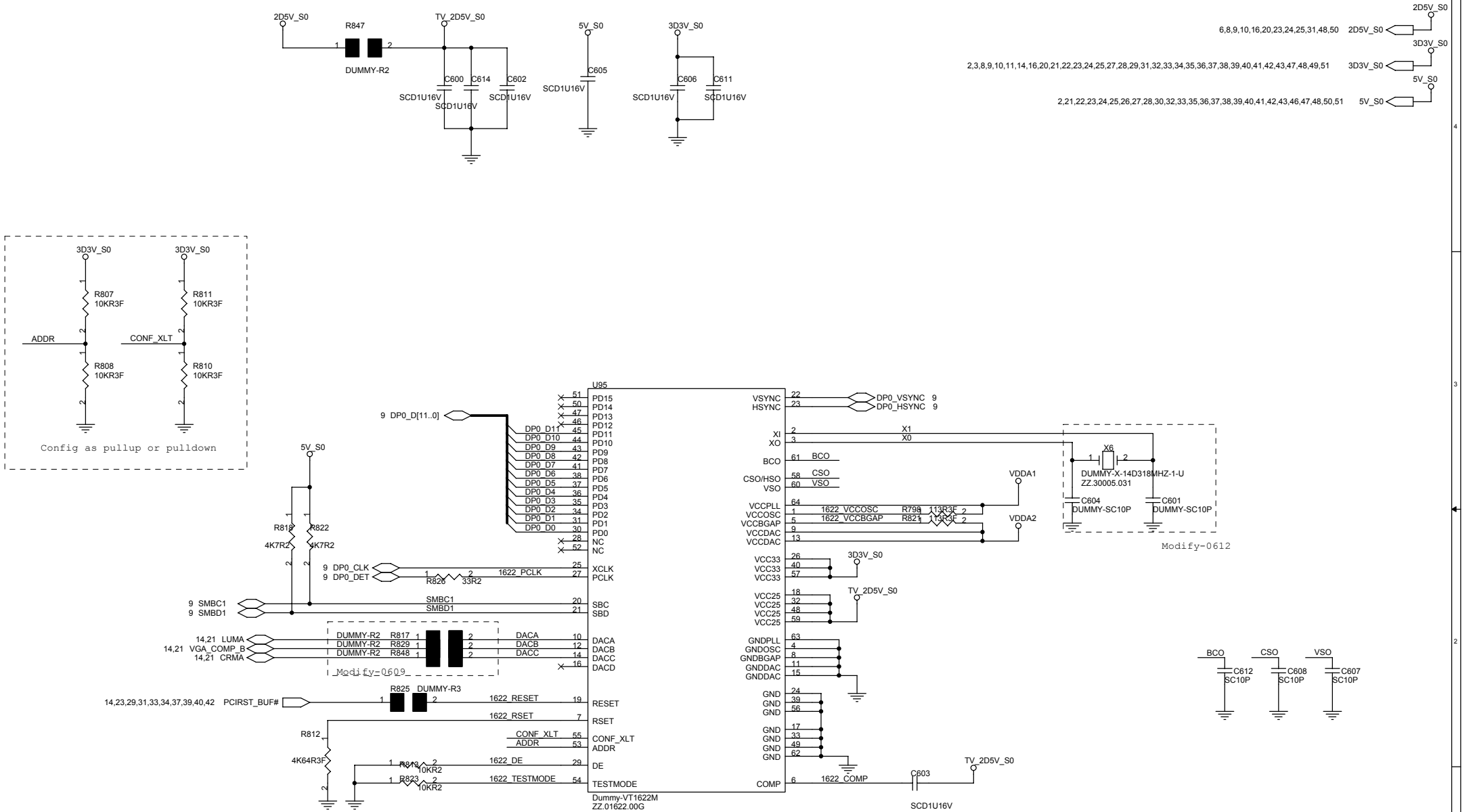

DUMMY-SRNO

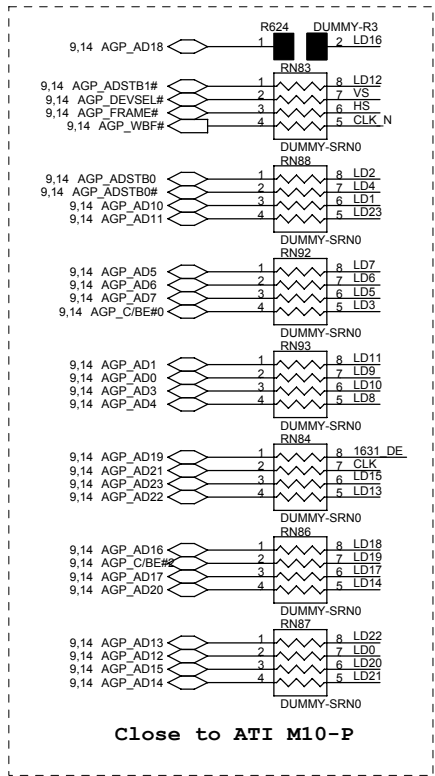

Close to ATI M10-P

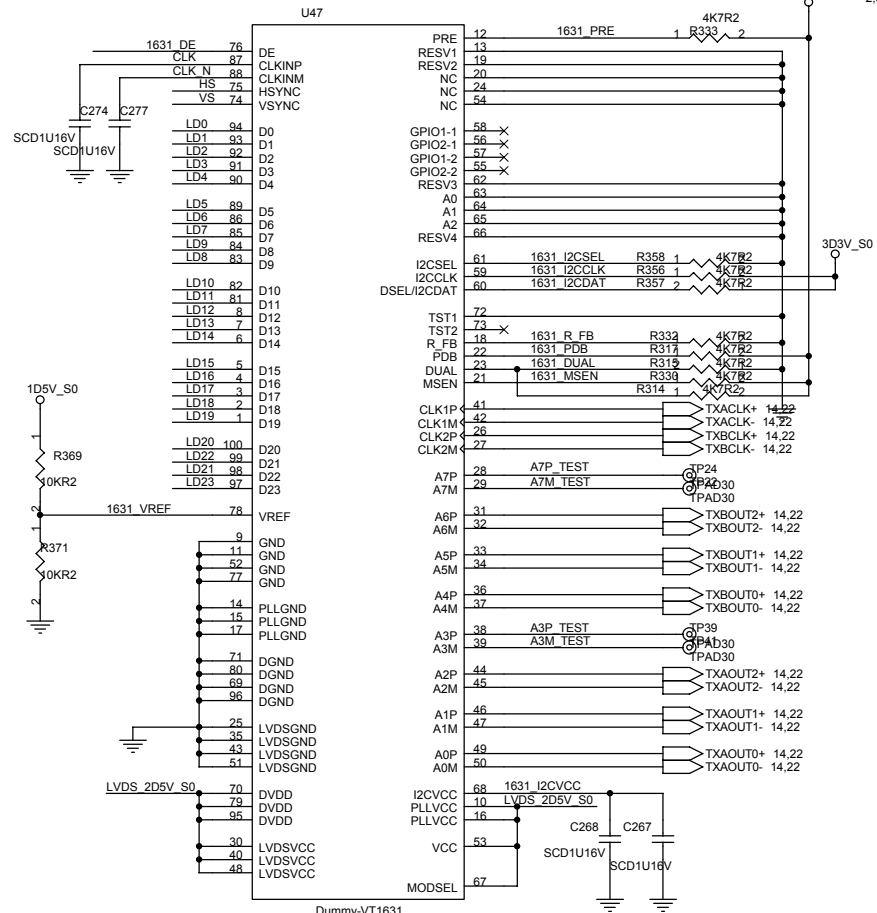

Dummy-VT1631
ZZ.V1631.00G

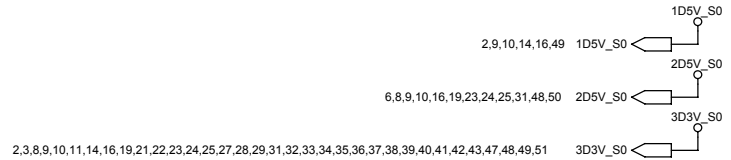
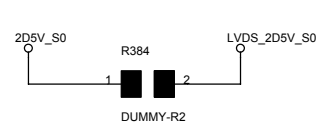

5/15
Remove the 5V_S0 C701-705
and 3D3V_S0 C693-C695

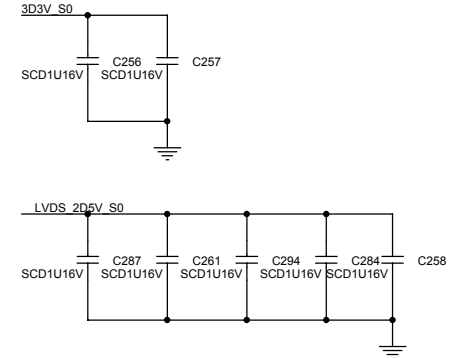

CRT

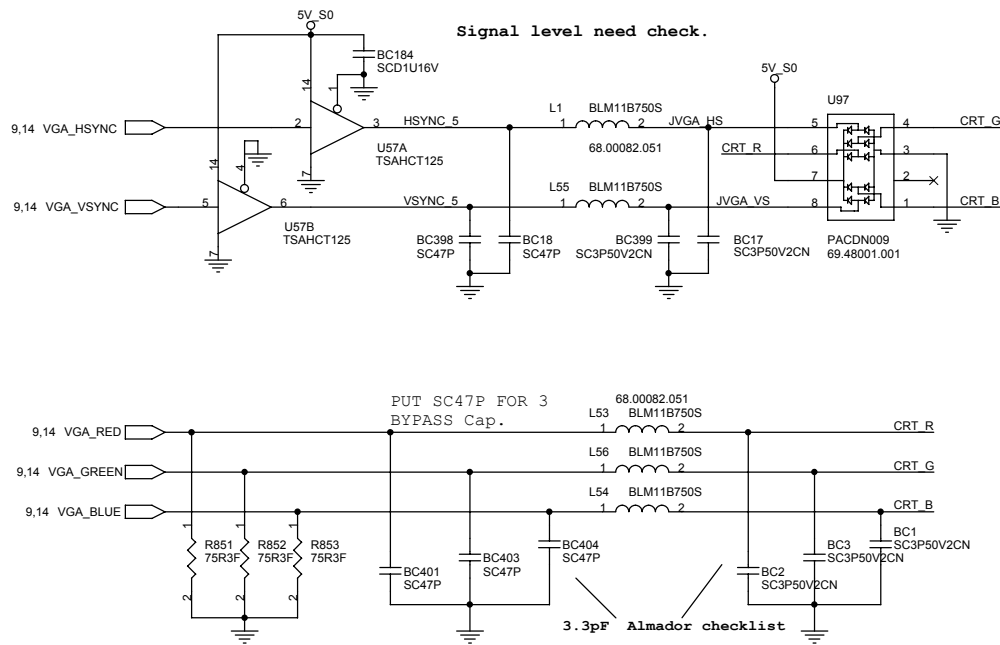

CRT CONN

200mA Rating/Spec 500mA

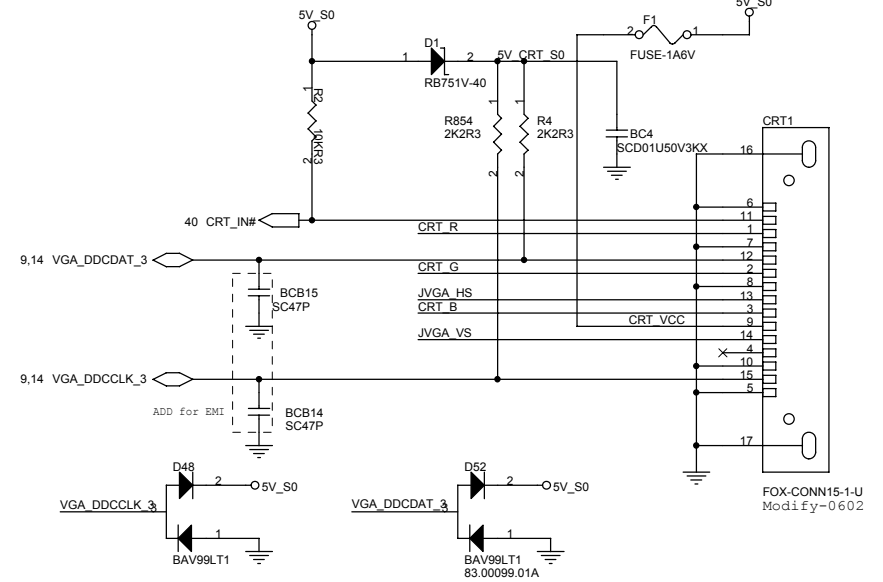

Layout Note:
Must be a ground return path between this ground and the ground on the VGA connector.
37.4 1% resistors must be placed after RGB pi filter ,near CRT connector.

TV CONN

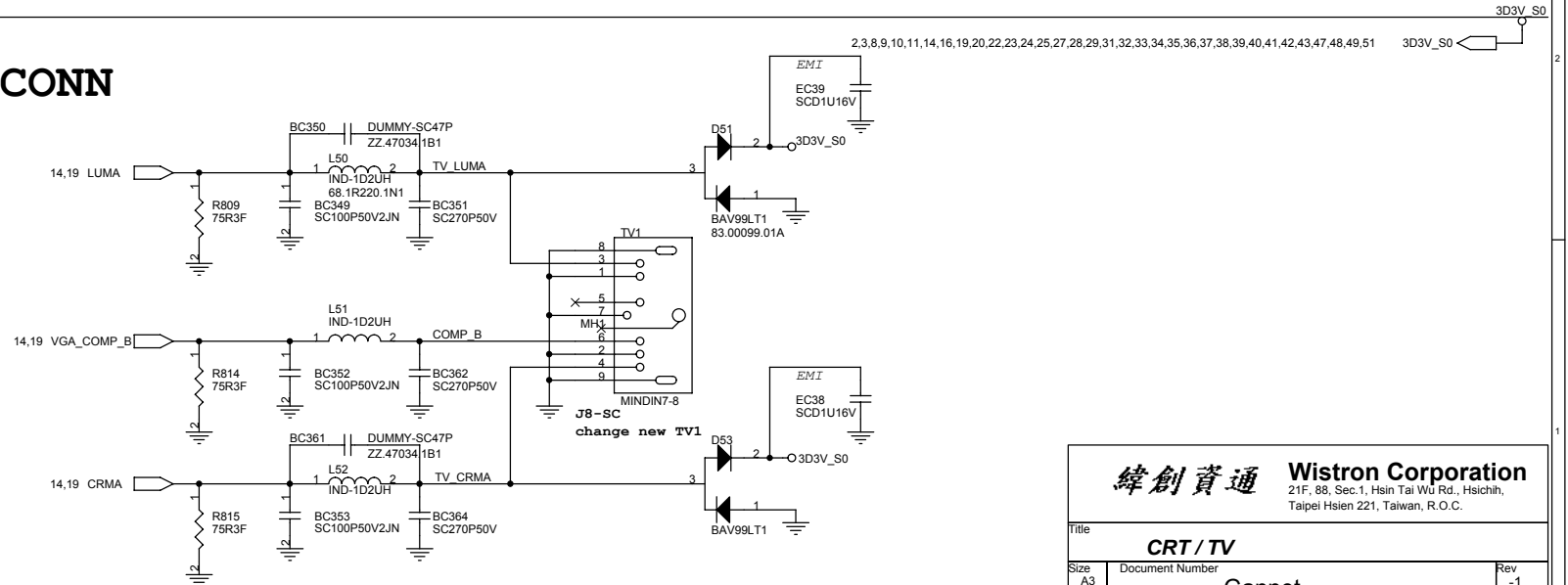

緯創資通		Wistron Corporation	
		21F, 88, Sec.1, Hsin Tai Wj Rd., Hsichih, Taipei Hsien 221, Taiwan, R.O.C.	
Title: CRT / TV			
Size: A3	Document Number:	Gannet	
Date: Thursday, December 04, 2003		Sheet: 21	of: 51
		Rev: -1	

INVERTER/LED

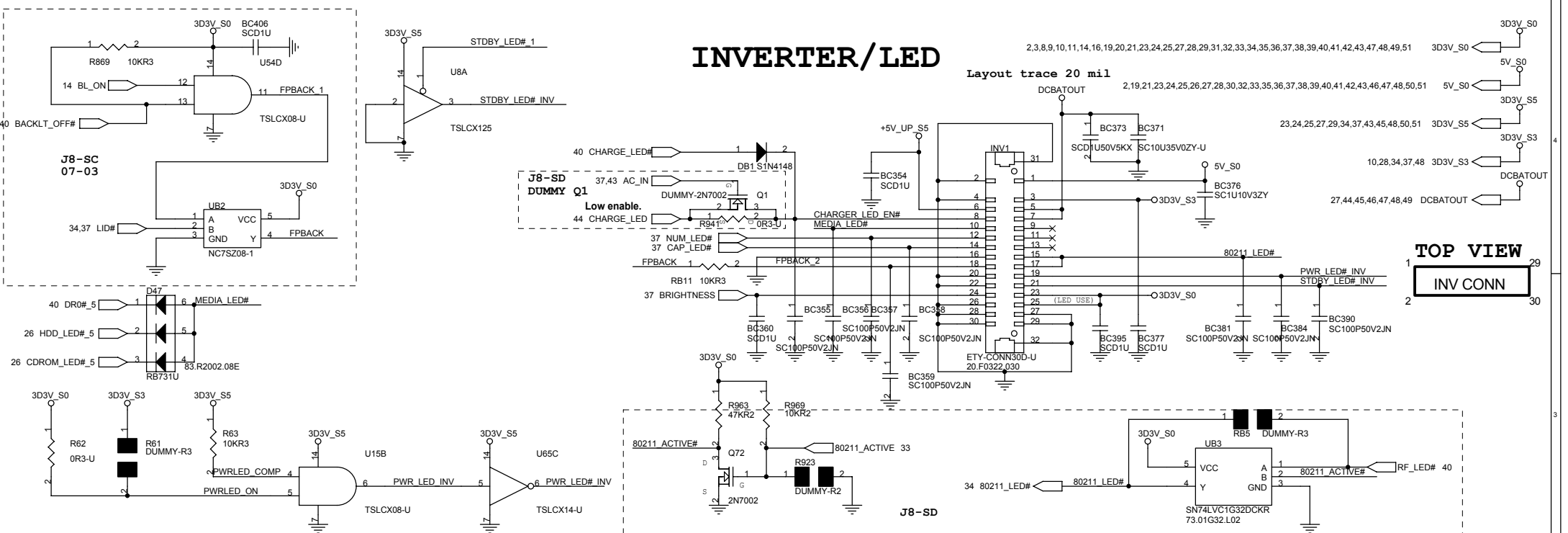

LCD POWER

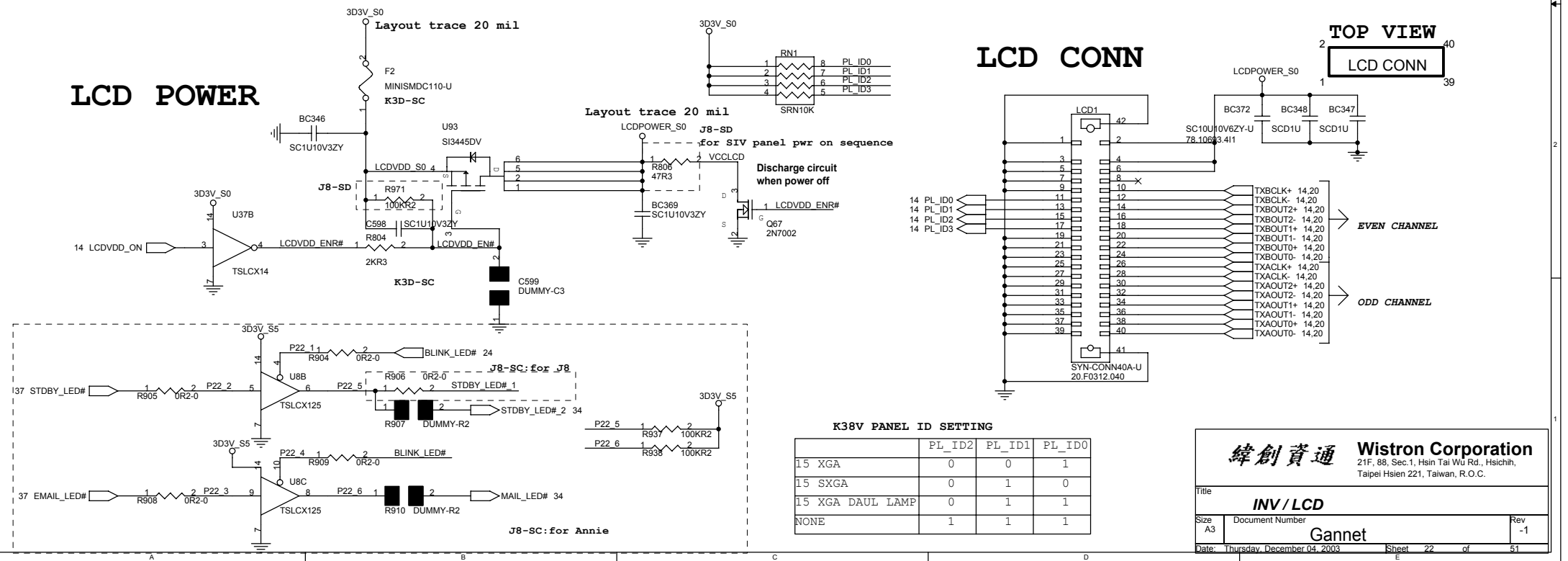

K38V PANEL ID SETTING

	PL_ID2	PL_ID1	PL_ID0
15 XGA	0	0	1
15 SXGA	0	1	0
15 XGA DAUL LAMP	0	1	1
NONE	1	1	1

緯創資通 Wistron Corporation
 21F, 88, Sec. 1, Hsin Tai WJ Rd., Hsichih, Taipei Hsien 221, Taiwan, R.O.C.

Title: **INV / LCD**

Size: A3 Document Number: **Gannet** Rev: -1

Date: Thursday, December 04, 2003 Sheet: 22 of 51

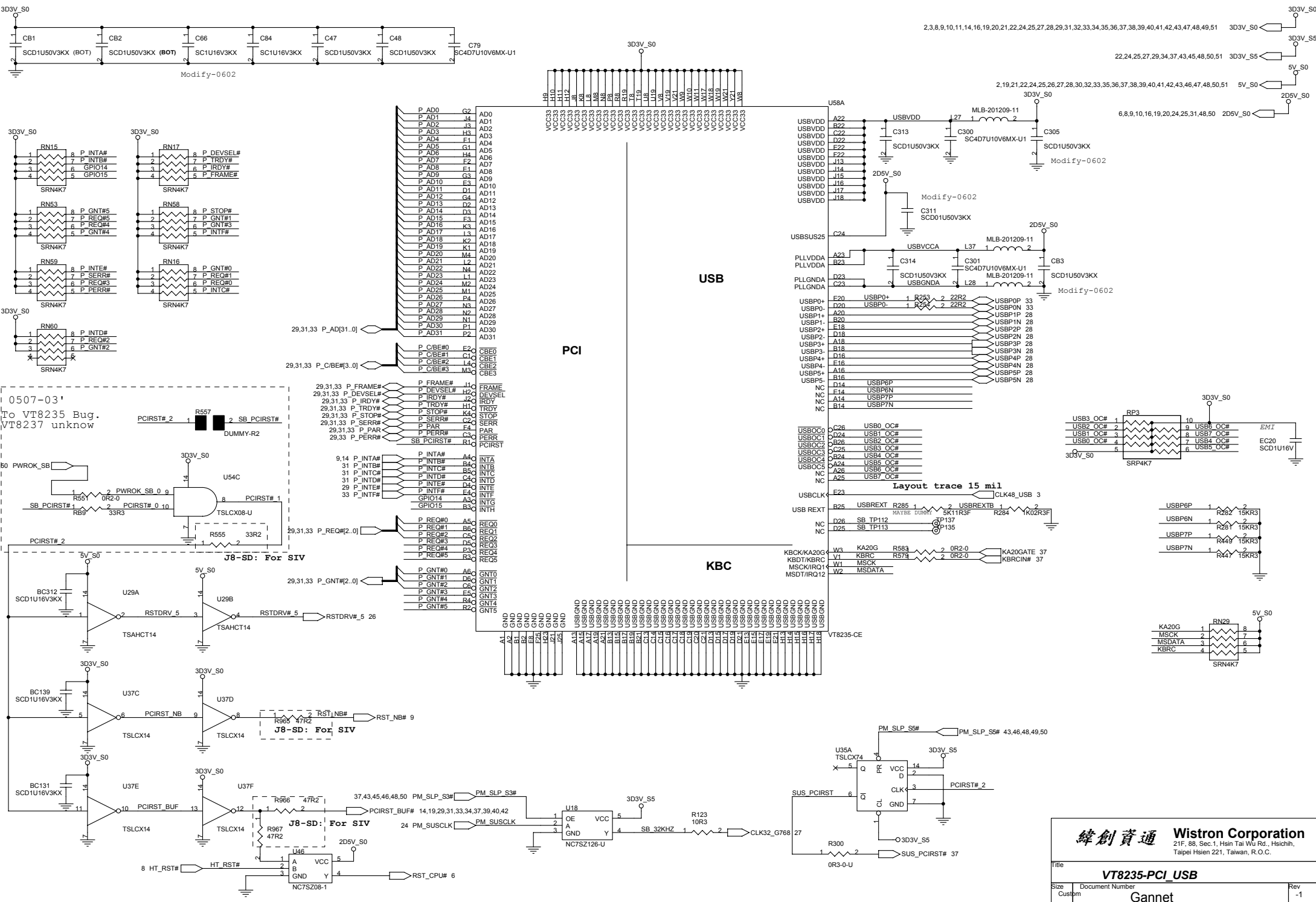

0507-03'
To VT8235 Bug.
VT8237 unknow

緯創資通 Wistron Corporation
21F, 88, Sec.1, Hsin Tai Wu Rd., Hsichih, Taipei Hsien 221, Taiwan, R.O.C.

File: **VT8235-PCI_USB**

Size	Document Number	Rev
Custom	Gannet	-1

Date: Thursday, December 04, 2003 Sheet 23 of 51

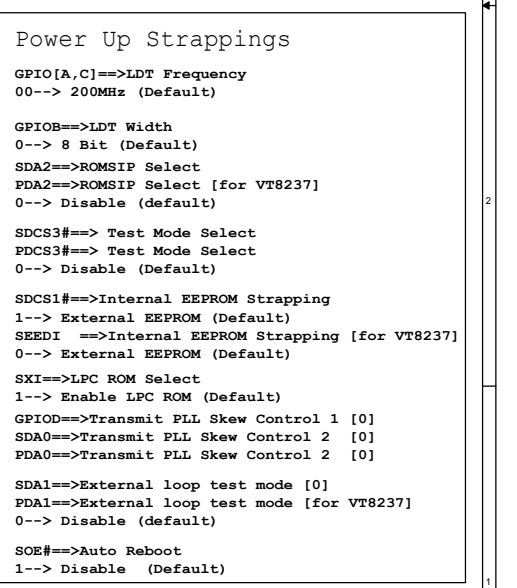
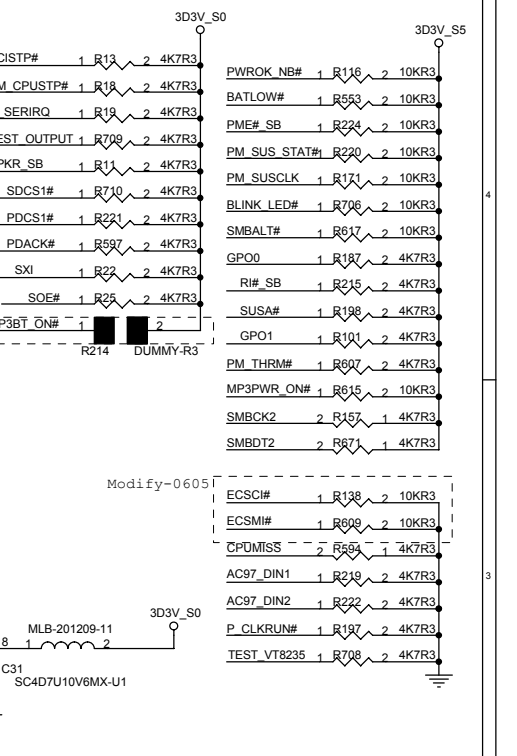
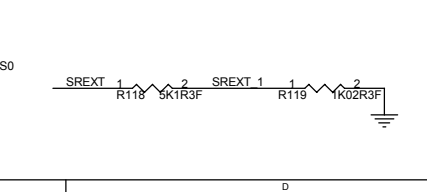
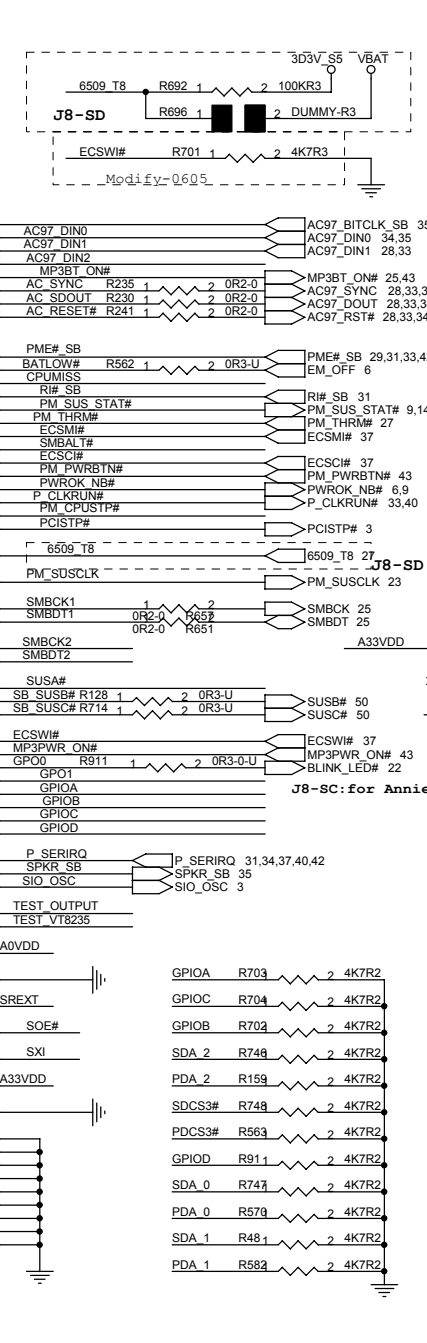
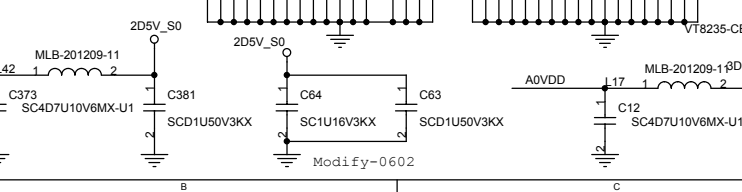
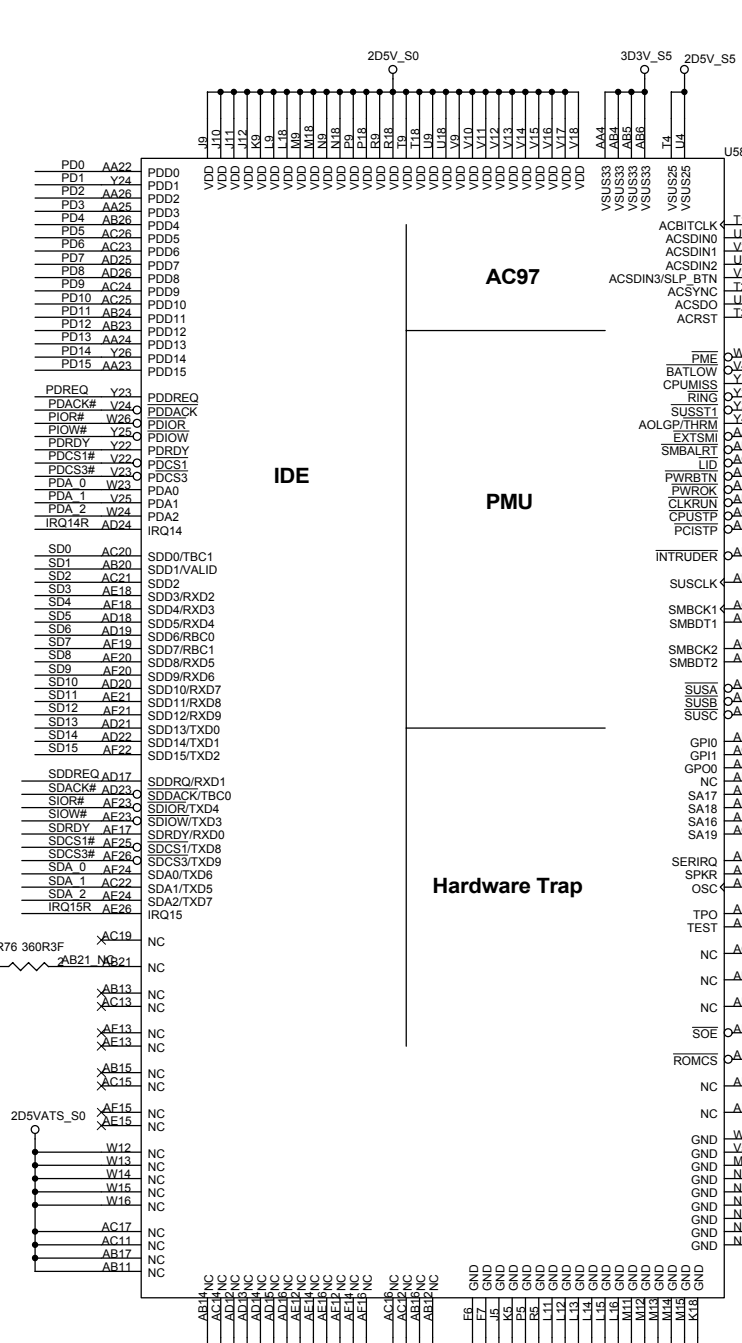
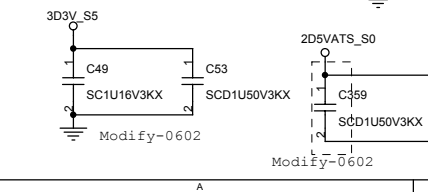
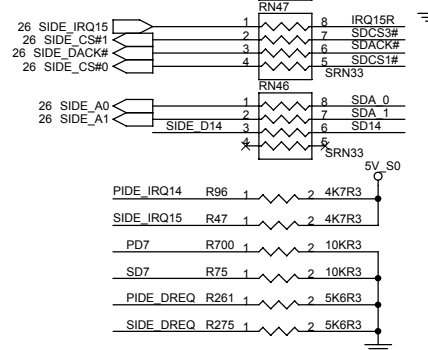
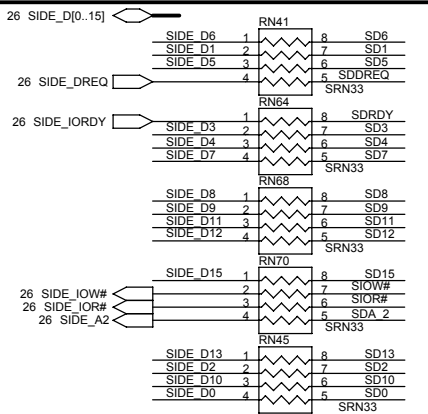
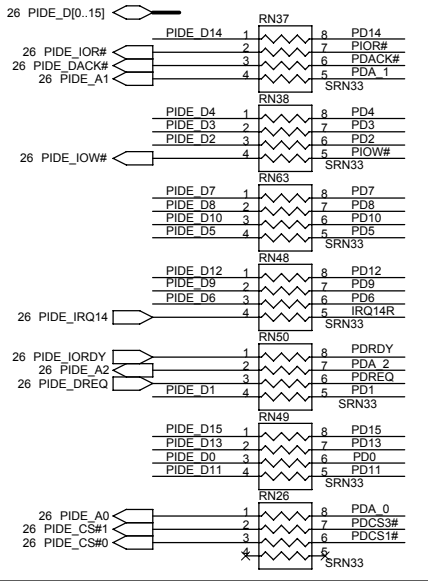

Power Up Strappings

GPIO[A,C]==>LDT Frequency
00--> 200MHz (Default)

GPIOB==>LDT Width
0--> 8 Bit (Default)

SDA2==>ROMSIP Select
FDA2==>ROMSIP Select [for VT8237]
0--> Disable (default)

SDCS3==> Test Mode Select
PDCS3==> Test Mode Select
0--> Disable (Default)

SDCS1==>Internal EEPROM Strapping
1--> External EEPROM (Default)
SEEDI ==>Internal EEPROM Strapping [for VT8237]
0--> External EEPROM (Default)

SXI==>LPC ROM Select
1--> Enable LPC ROM (Default)

GPIOD==>Transmit PLL Skew Control 1 [0]
SDA0==>Transmit PLL Skew Control 2 [0]
FDA0==>Transmit PLL Skew Control 2 [0]

SDA1==>External loop test mode [0]
FDAl==>External loop test mode [for VT8237]
0--> Disable (default)

SOE==>Auto Reboot
1--> Disable (Default)

緯創資通 Wistron Corporation
21F, 88, Sec.1, Hsin Tai Wj Rd., Hsichih, Taipei Hsien 221, Taiwan, R.O.C.

Title		VT8235-IDE_AC97_PMU	
Size	A3	Document Number	Gannet
Date:	Thursday, December 04, 2003	Sheet	24 of 51

HDD

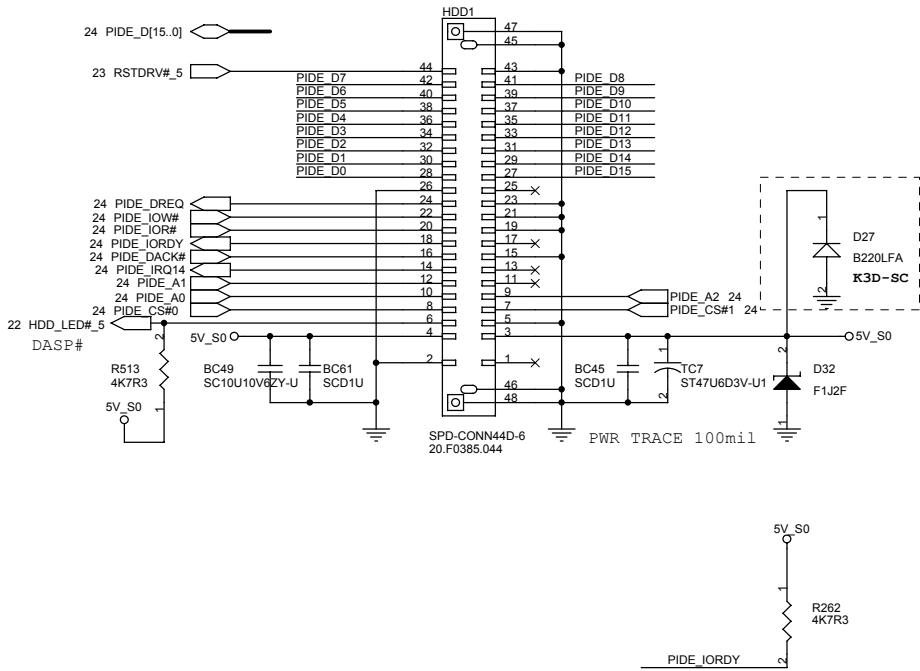

CDROM

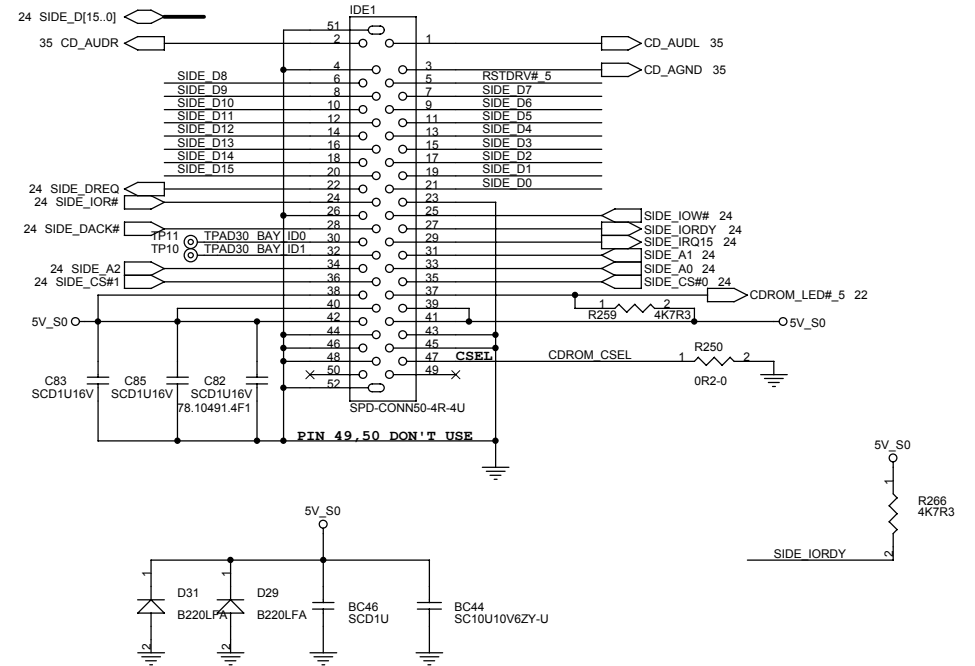

緯創資通 Wistron Corporation
 21F, 88, Sec.1, Hsin Tai WJ Rd., Hsichih,
 Taipei Hsien 221, Taiwan, R.O.C.

Title HDD / CDROM		
Size A3	Document Number Gannet	Rev -1
Date: Thursday, December 04, 2003 Sheet 26 of 51		

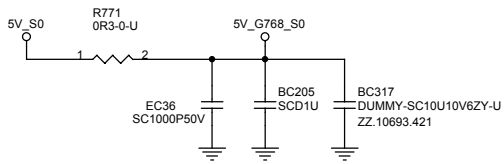

Put these two Caps near the thermal diode.

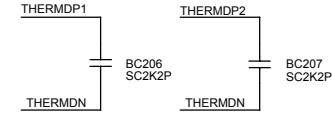
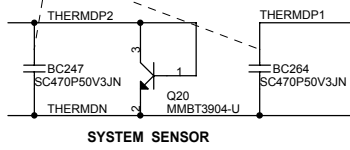

THERMDP1/DP2/THERMDN ON THE SAME LAYER
W/S = 10/5 MIL, 12 MIL AWAY FROM OTHERS
CAPS CLOSE TO G768B

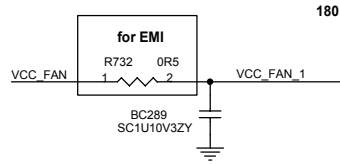

180 ms after VCC_G768 > 4.38v, p2, 7

For Ni-MH Battery BL3 Soltion

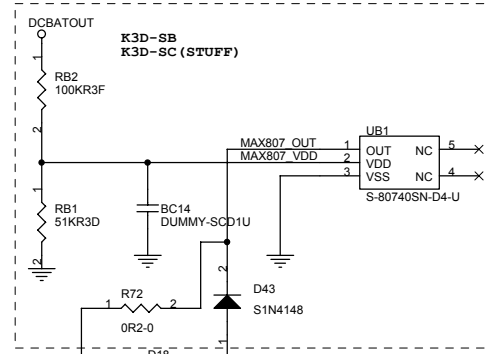

Reserve for G768B works at High Speed

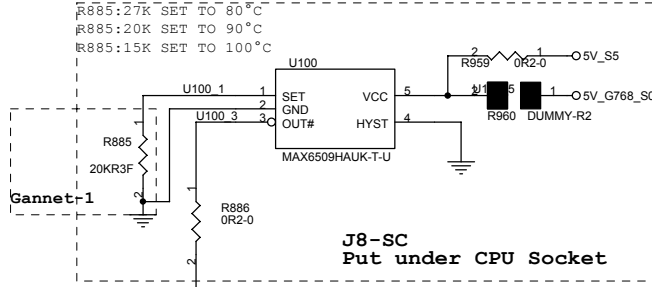
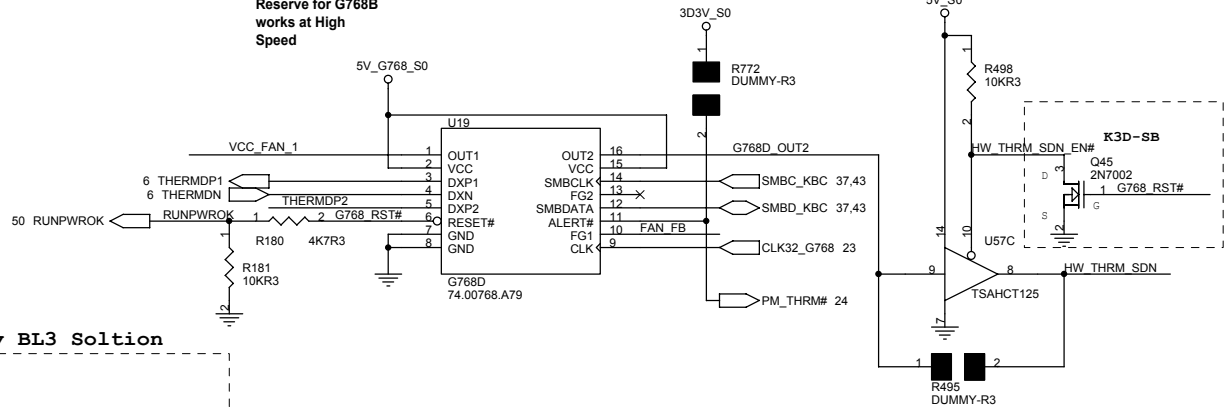

J8-SC Put under CPU Socket

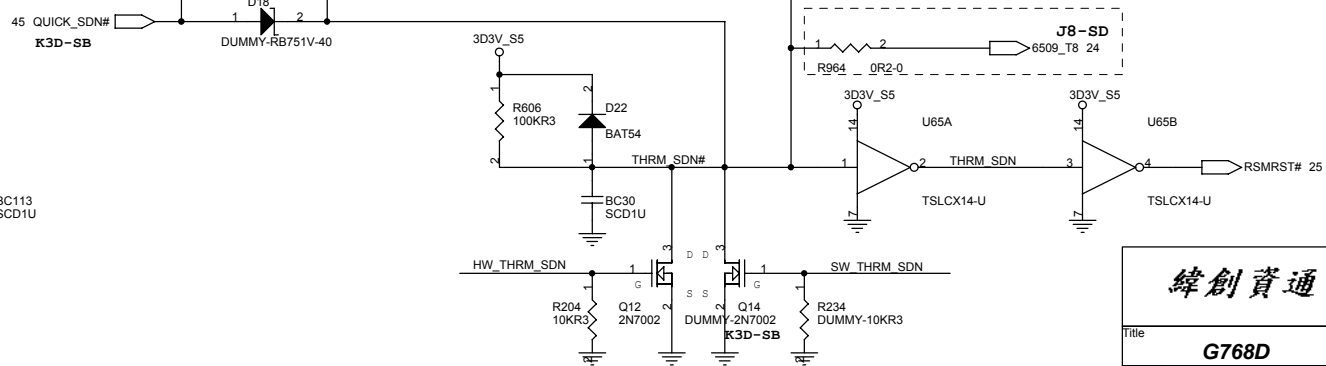
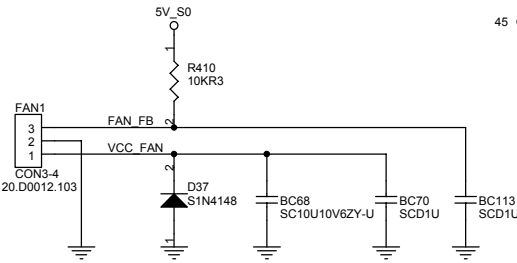

緯創資通 Wistron Corporation	
21F, 88, Sec.1, Hsin Tai Wj Rd., Hsichih, Taipei Hsien 221, Taiwan, R.O.C.	
Title G768D	
Size A3	Document Number
Gannet	
Date: Thursday, December 04, 2003	Sheet 27 of 51

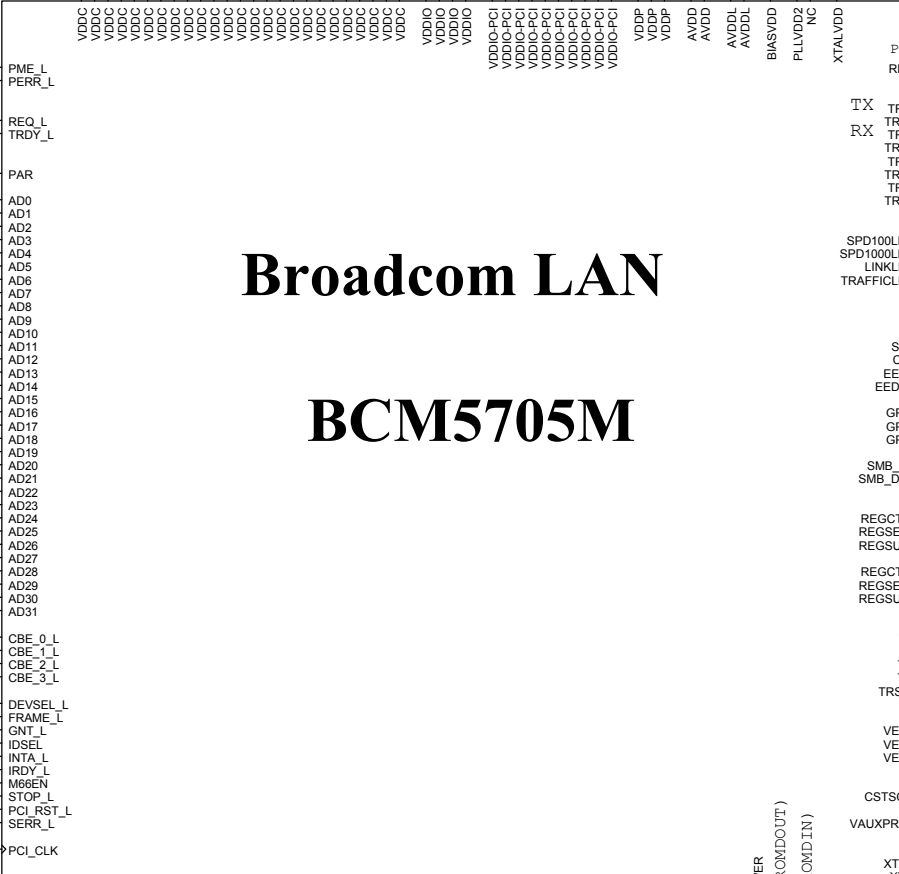
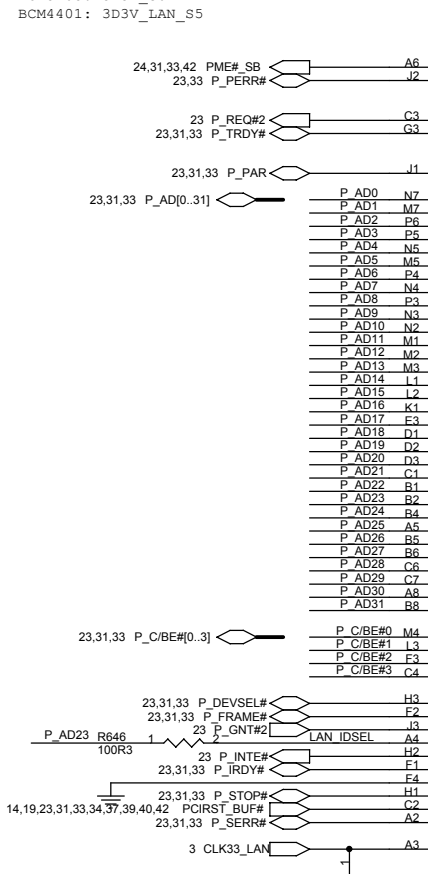
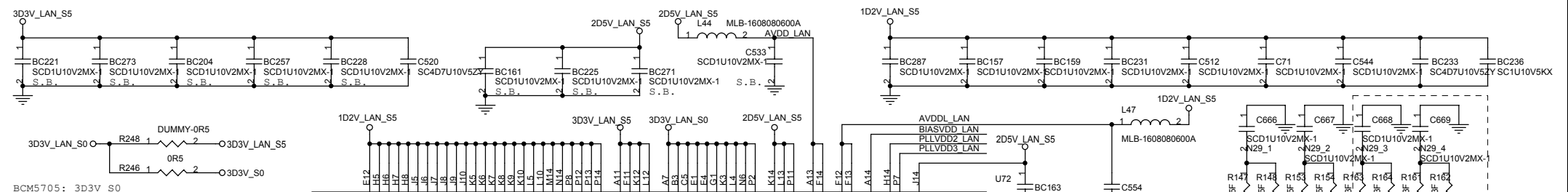

Broadcom LAN BCM5705M

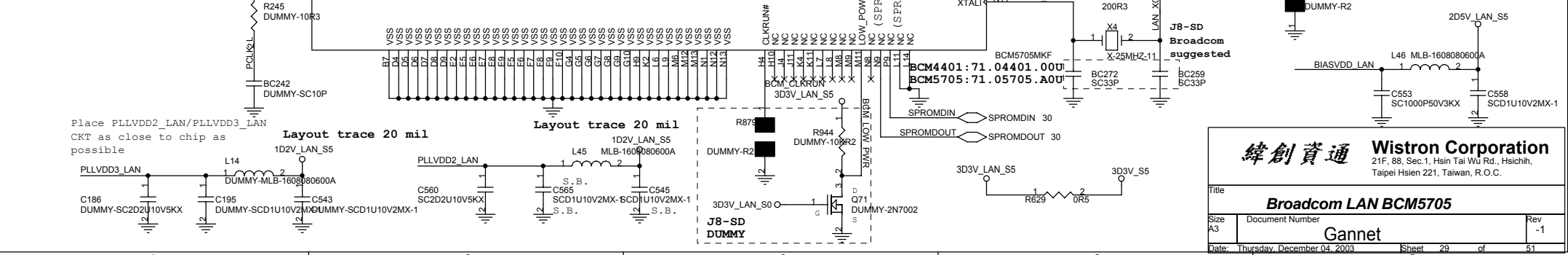
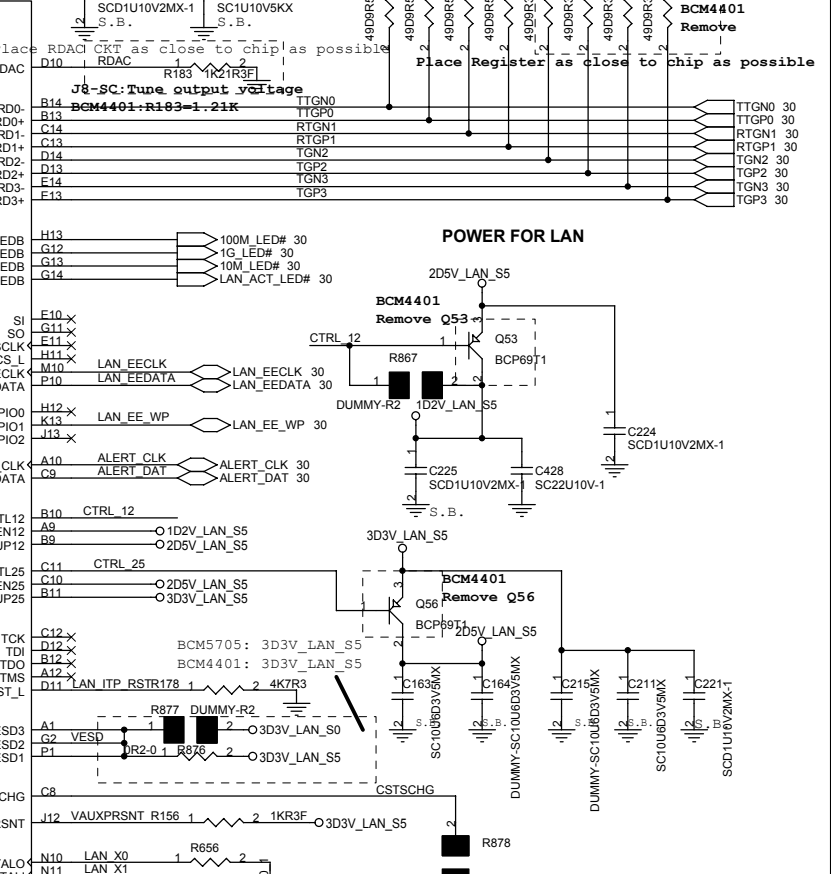

緯創資通 Wistron Corporation
21F, 88, Sec. 1, Hsin Tai Wj Rd., Hsichih, Taipei Hsien 221, Taiwan, R.O.C.

Broadcom LAN BCM5705	
File	Rev
Size A3	Document Number
Gannet	
Date: Thursday, December 04, 2003 Sheet 29 of 51	

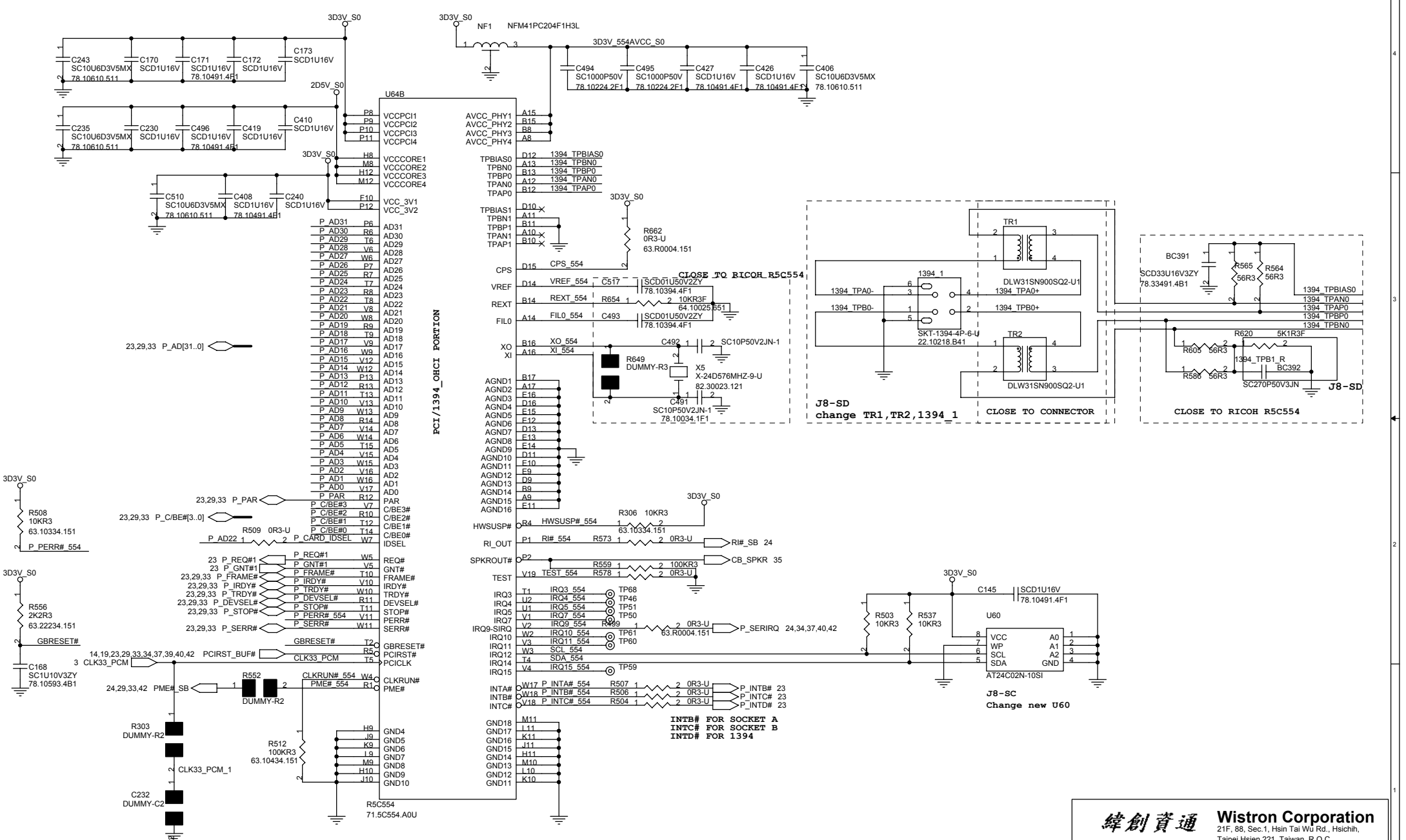

緯創資通 Wistron Corporation
 21F, 88, Sec. 1, Hsin Tai Wj Rd., Hsichih,
 Taipei Hsien 221, Taiwan, R.O.C.

Title: **RICOH_R5C554(1/2)_1394**

Size: A3	Document Number: Gannet	Rev: -1
----------	--------------------------------	---------

Date: Thursday, December 04, 2003 Sheet 31 of 51

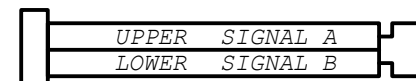

SIGNAL B SIGNAL A

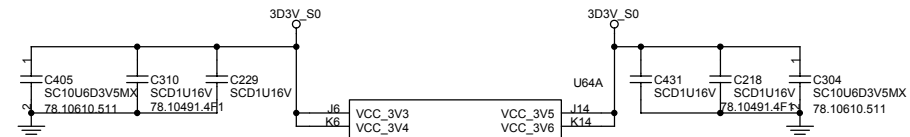

B_CAD19	G1	BCADR25	CAD19	ACADR25	H14	A_CAD19
B_CAD17	G4	BCADR24	CAD17	ACADR24	H15	A_CAD17
B_CFRAME#	G6	BCADR23	CFRAME#	ACADR23	K18	A_CFRAME#
B_CTRDY#	F2	BCADR22	CTRDY#	ACADR22	K15	A_CTRDY#
B_CDEVSEL#	F5	BCADR21	CDEVSEL#	ACADR21	L18	A_CDEVSEL#
B_CSTOP#	F1	BCADR20	CSTOP#	ACADR20	L15	A_CSTOP#
B_CBLOCK#	F4	BCADR19	CBLOCK#	ACADR19	M16	A_CBLOCK#
B_RSVD_A18	D1	BCADR18	RSVD_A18	ACADR18	M19	A_RSVD_A18
B_CAD16	D4	BCADR17	CAD16	ACADR17	K16	A_CAD16
B_CCLK	F4	BCADR16	CCLK	ACADR16	K19	A_CCLK
B_CIRDY#	F1	BCADR15	CIRDY#	ACADR15	L14	A_CIRDY#
B_CPERR#	F5	BCADR14	CPERR#	ACADR14	M18	A_CPERR#
B_CPAR	D2	BCADR13	CPAR	ACADR13	N16	A_CPAR
B_CC/BE#2	G5	BCADR12	CC/BE#2	ACADR12	P18	A_CC/BE#2
B_CAD12	A2	BCADR11	CAD12	ACADR11	N16	A_CAD12
B_CAD9	B4	BCADR10	CAD9	ACADR10	P18	A_CAD9
B_CAD14	B1	BCADR9	CAD14	ACADR9	N19	A_CAD14
B_CC/BE#1	C1	BCADR8	CC/BE#1	ACADR8	M15	A_CC/BE#1
B_CAD18	G2	BCADR7	CAD18	ACADR7	J19	A_CAD18
B_CAD20	H6	BCADR6	CAD20	ACADR6	H15	A_CAD20
B_CAD21	H4	BCADR5	CAD21	ACADR5	L12	A_CAD21
B_CAD22	H1	BCADR4	CAD22	ACADR4	G14	A_CAD22
B_CAD23	J4	BCADR3	CAD23	ACADR3	G16	A_CAD23
B_CAD24	J1	BCADR2	CAD24	ACADR2	G19	A_CAD24
B_CAD25	K4	BCADR1	CAD25	ACADR1	F16	A_CAD25
B_CAD26	K1	BCADR0	CAD26	ACADR0	F19	A_CAD26

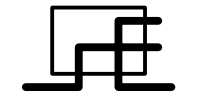
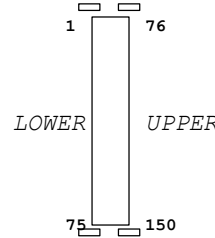

SIGNALB SIGNALA
Upper = Slot0 / Signal A = Conn B
Lower = Slot1 / Signal B = Conn A

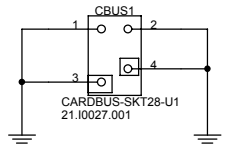

B_CAD8	A5	BCDATA15	CAD8	ACDATA15	P16	A_CAD8
B_RSVD_D14	D5	BCDATA14	RSVD_D14	ACDATA14	P14	A_RSVD_D14
B_CAD6	B6	BCDATA13	CAD6	ACDATA13	R18	A_CAD6
B_CAD4	F6	BCDATA12	CAD4	ACDATA12	R15	A_CAD4
B_CAD2	B7	BCDATA11	CAD2	ACDATA11	T18	A_CAD2
B_CAD30	M5	BCDATA10	CAD30	ACDATA10	C18	A_CAD30
B_CAD28	L4	BCDATA9	CAD28	ACDATA9	D18	A_CAD28
B_CAD7	A6	BCDATA7	CAD7	ACDATA7	R19	A_CAD7
B_CAD5	D6	BCDATA6	CAD5	ACDATA6	R16	A_CAD5
B_CAD3	A7	BCDATA5	CAD3	ACDATA5	T19	A_CAD3
B_CAD1	D7	BCDATA4	CAD1	ACDATA4	T18	A_CAD1
B_CAD0	E7	BCDATA3	CAD0	ACDATA3	U18	A_CAD0
B_RSVD_D2	M6	BCDATA2	RSVD_D2	ACDATA2	C19	A_RSVD_D2
B_CAD29	L2	BCDATA1	CAD29	ACDATA1	D19	A_CAD29
B_CAD27	L5	BCDATA0	CAD27	ACDATA0	F19	A_CAD27

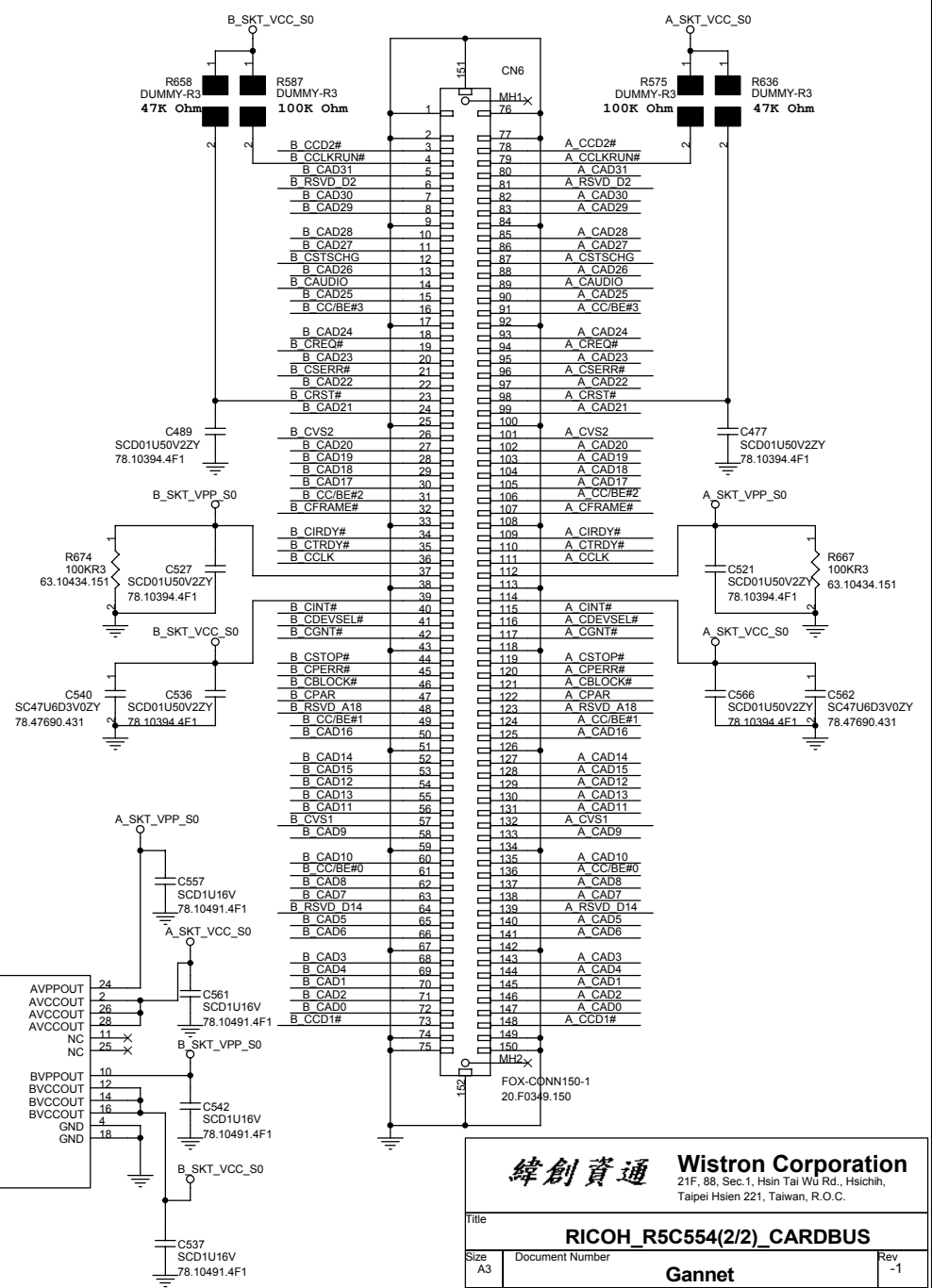
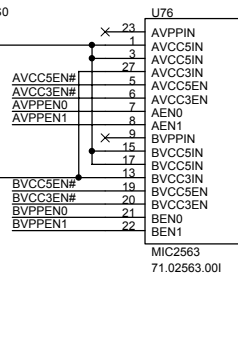
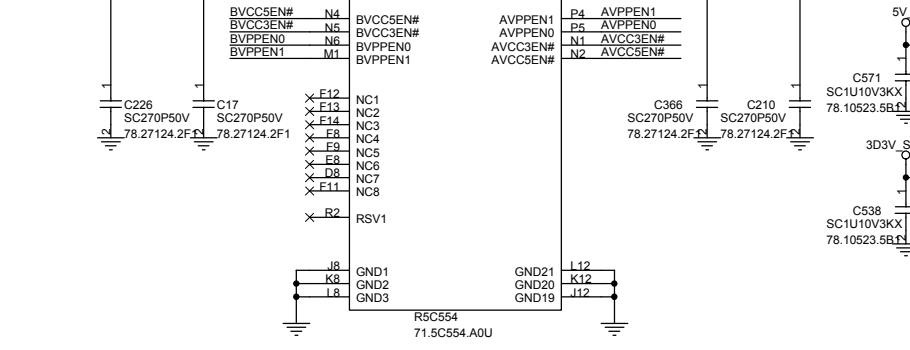

緯創資通 Wistron Corporation
21F, 88, Sec.1, Hsin Tai Wu Rd., Hsichih, Taipei Hsien 221, Taiwan, R.O.C.

RICOH_R5C554(2/2)_CARBUS

Title: _____
Size: A3 Document Number: _____ Rev: -1
Date: Thursday, December 04, 2003 Sheet: 32 of 51

25.37.39.40.42 LPC_LAD[3..0]

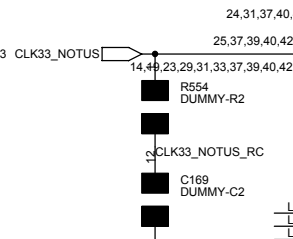

**For Non-MP3 Model
PUT INSIDE OZ263**

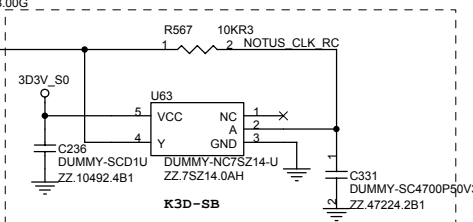
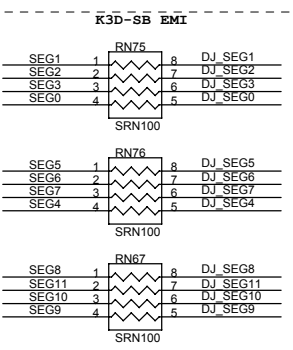
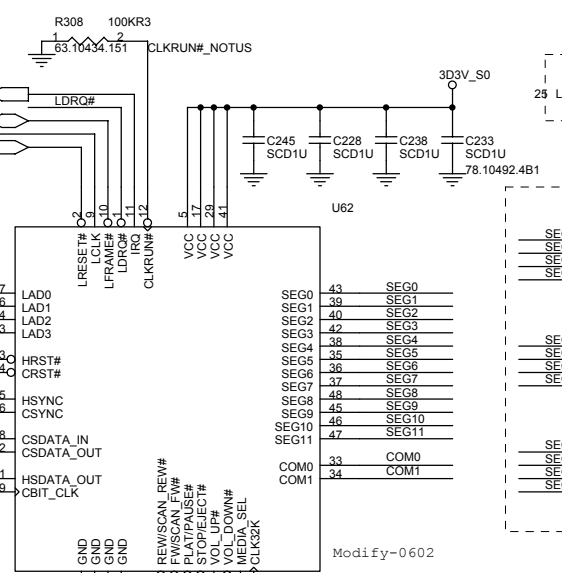
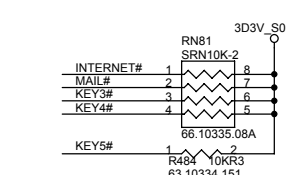
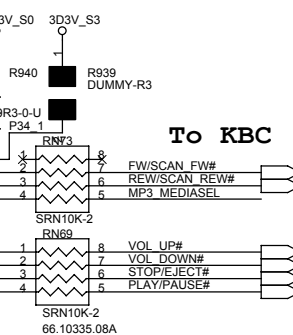
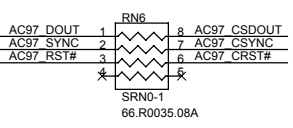

MP3 POWER BUTTON

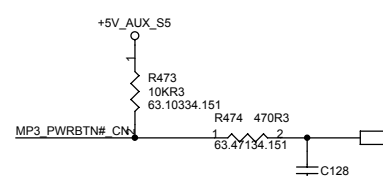

POWER BUTTON

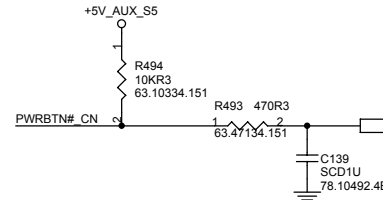

J8-SC: For Annie

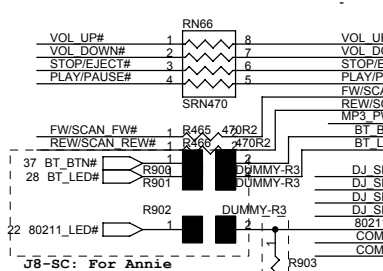
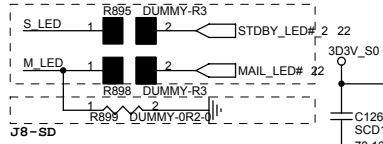

J8-SC: For Annie

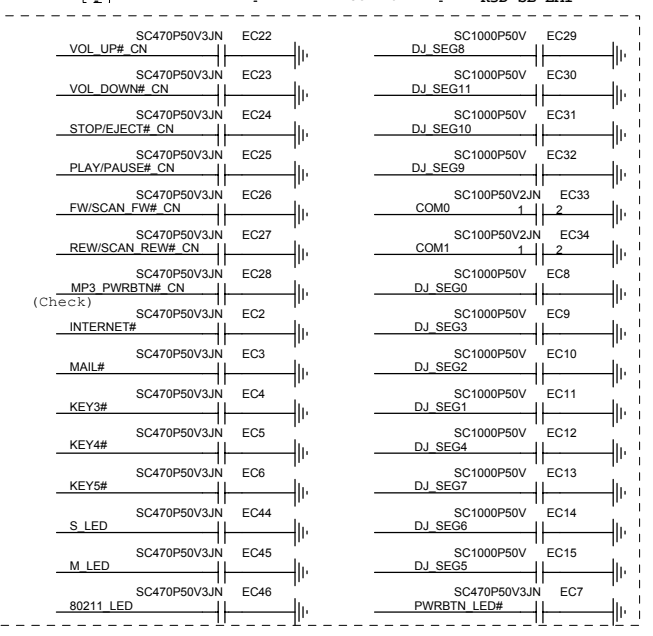
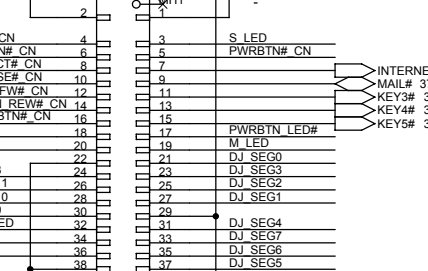
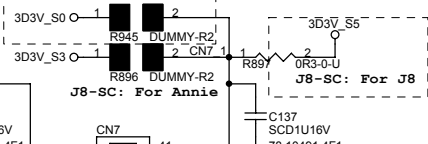

緯創資通 Wistron Corporation
21F, 88, Sec. 1, Hsin Tai Wu Rd., Hsichih, Taipei Hsien 221, Taiwan, R.O.C.

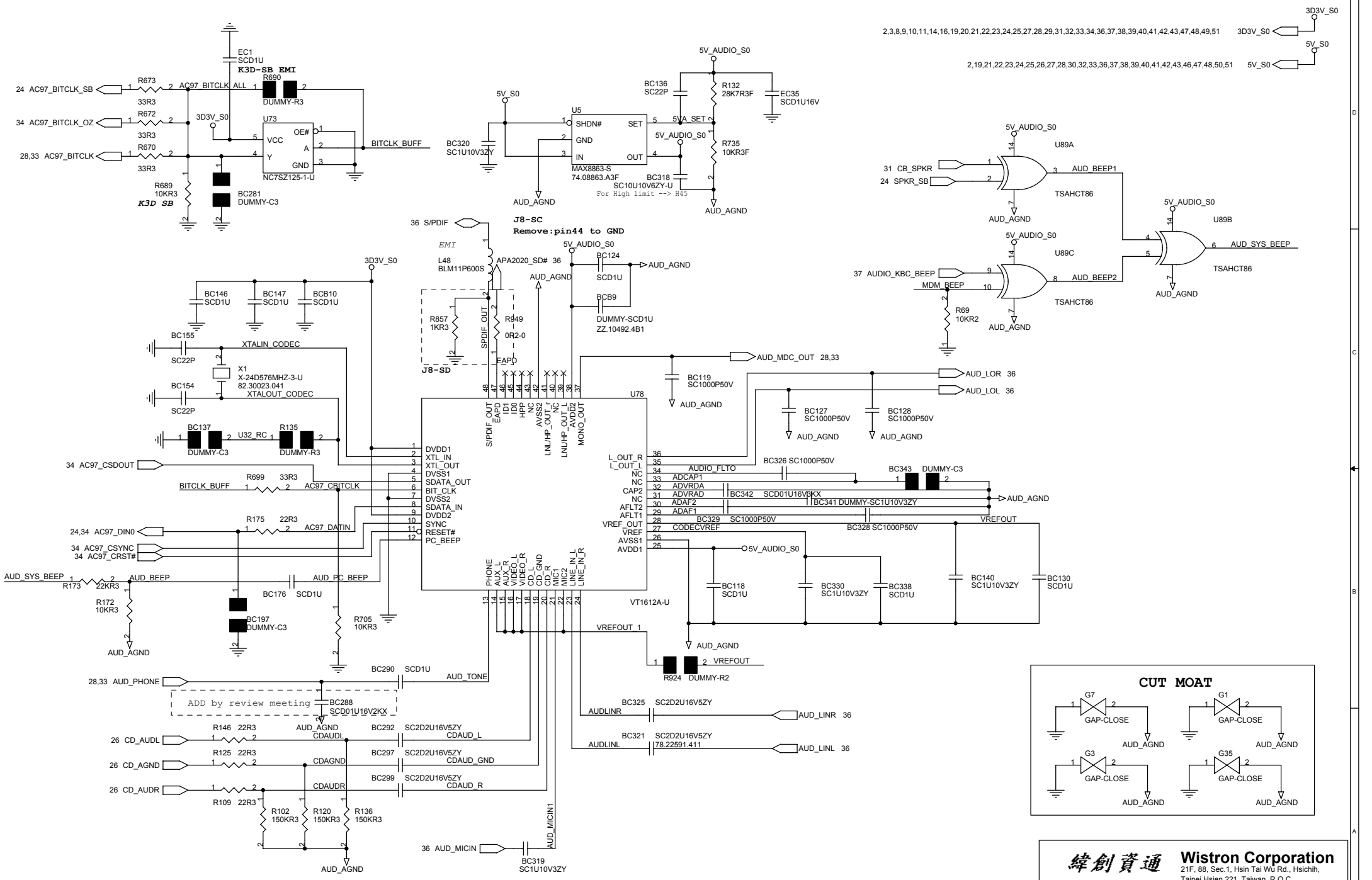

2,3,8,9,10,11,14,16,19,20,21,22,23,24,25,27,28,29,31,32,33,34,36,37,38,39,40,41,42,43,47,48,49,51 3D3V_S0

2,19,21,22,23,24,25,26,27,28,30,32,33,36,37,38,39,40,41,42,43,46,47,48,50,51 5V_S0

J8-SC
Remove:pin44 to GND

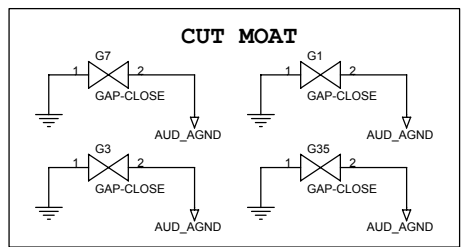

緯創資通 Wistron Corporation
21F, 88, Sec.1, Hsin Tai Wj Rd., Hsichih, Taipei Hsien 221, Taiwan, R.O.C.

Title: **AUDIO (1/2) -- CODEC VT1612A**

Size: A3	Document Number: Gannet	Rev: -1
----------	-------------------------	---------

Date: Thursday, December 04, 2003 Sheet 35 of 51

J8-SC
Delete "Bo" sound



For depop

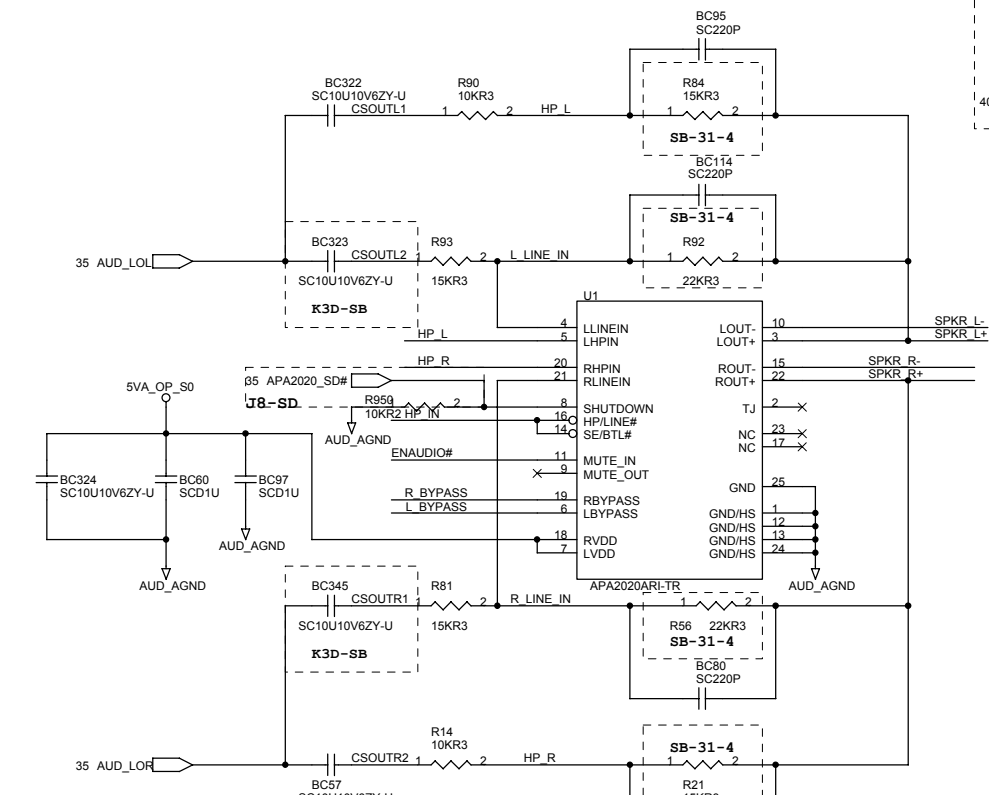
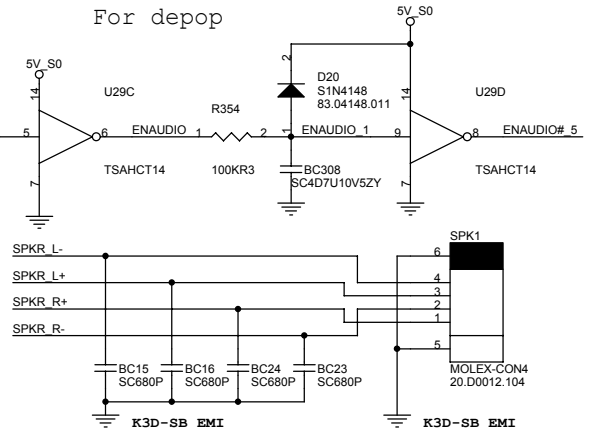

MIC PREAMP

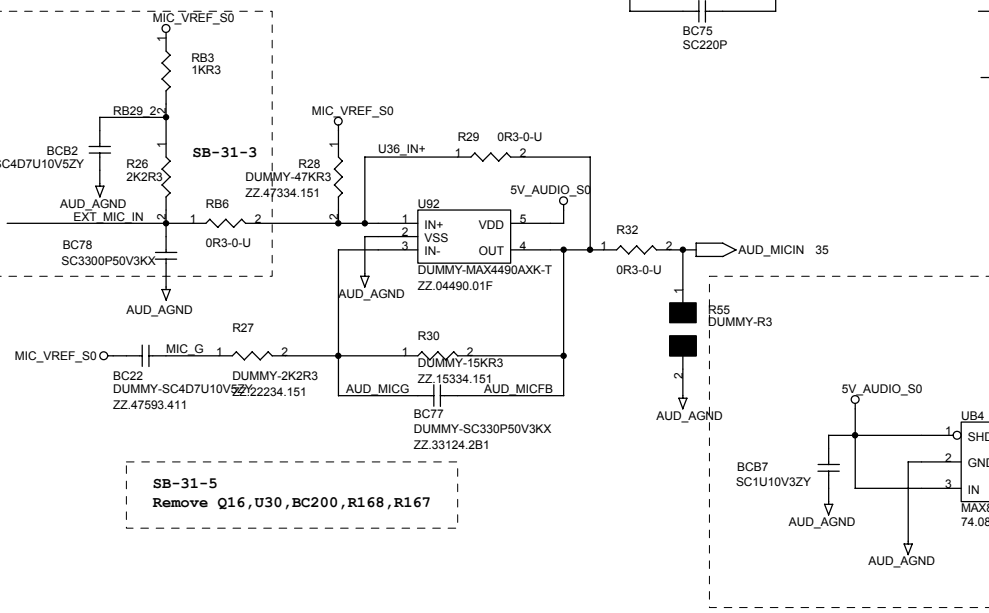

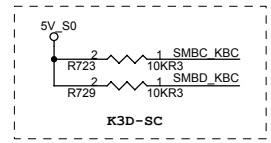
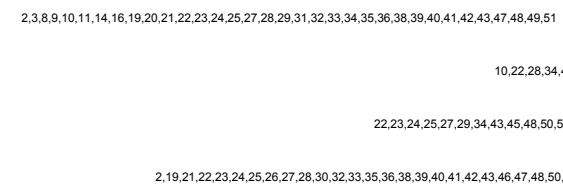

NEAR M38859

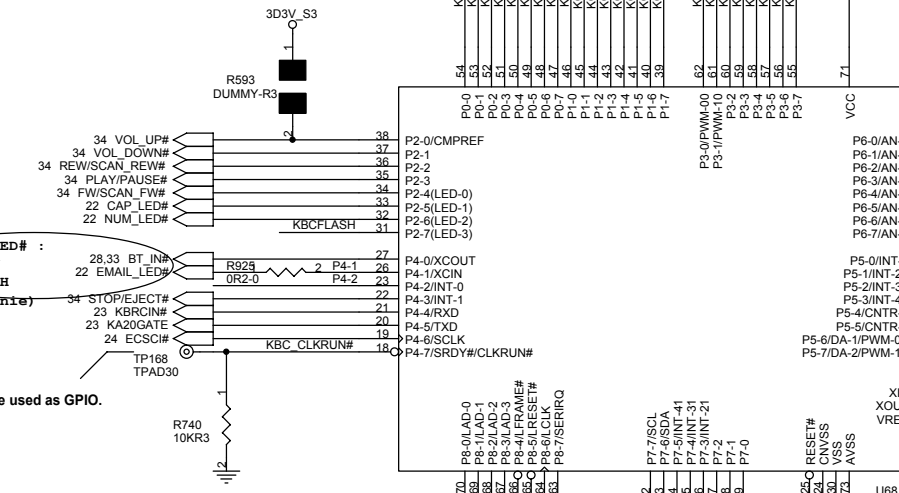
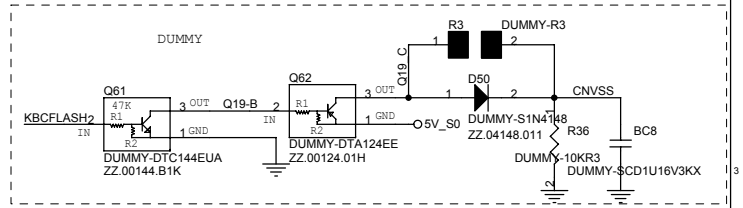
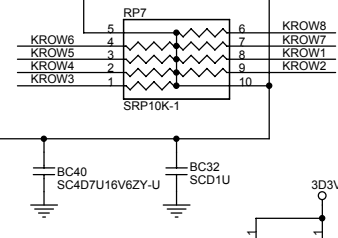

PS/2 CONN

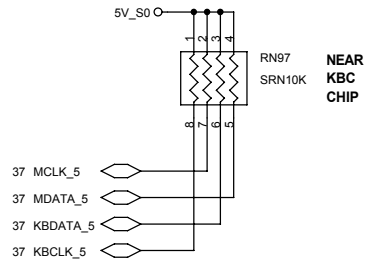

2,3,8,9,10,11,14,16,19,20,21,22,23,24,25,27,28,29,31,32,33,34,35,36,37,39,40,41,42,43,47,48,49,51

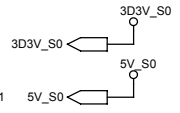

2,19,21,22,23,24,25,26,27,28,30,32,33,35,36,37,39,40,41,42,43,46,47,48,50,51

TOUCH PAD

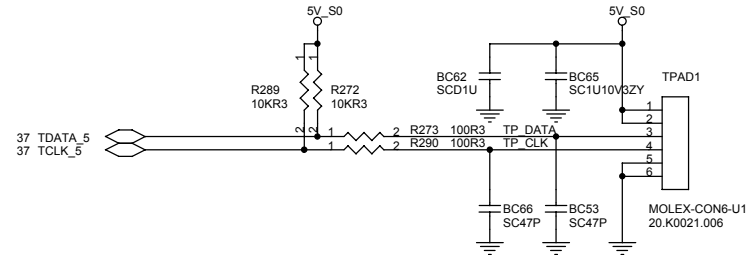

Internal Keyboard CONN

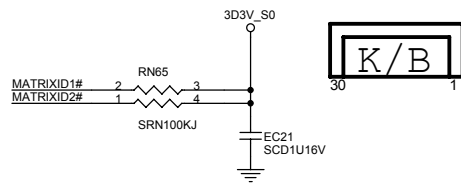

SB

Keyboard matrix (from vendor)

	US	Jap	Eur	Other	
Low Bit	MATRIXID1#	1	1	0	0
High Bit	MATRIXID2#	1	0	1	0

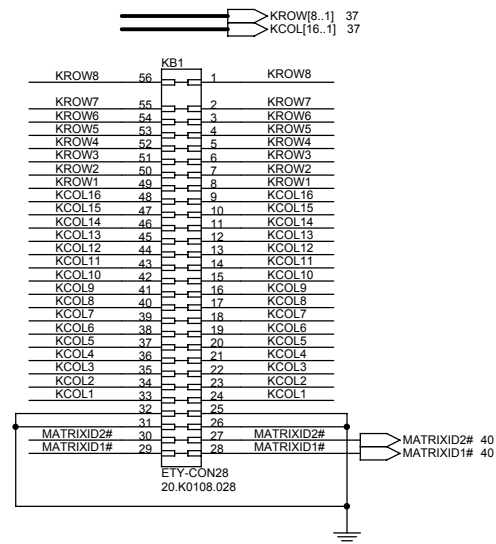

7/09 EMI Bypass cap.

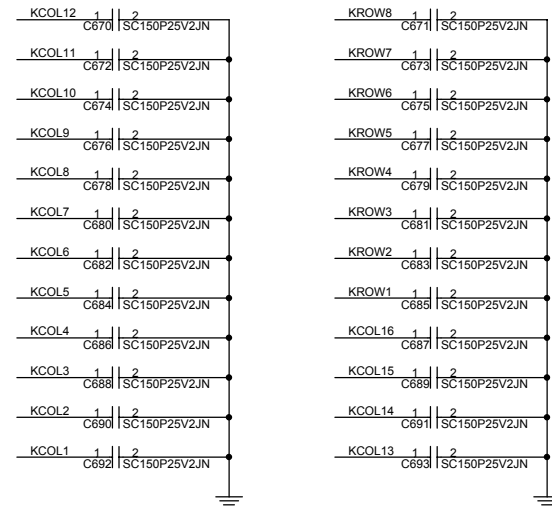

緯創資通 Wistron Corporation
21F, 88, Sec.1, Hsin Tai Wj Rd., Hsichih, Taipei Hsien 221, Taiwan, R.O.C.

Title			PS2 / TOUCHPAD / KB CONN	
Size	Document Number		Rev	
A3	Gannet		-1	
Date: Thursday, December 04, 2003			Sheet	38 of 51

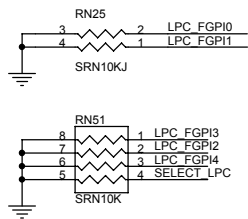

25,34,37,40,42 LPC_LAD[3..0]

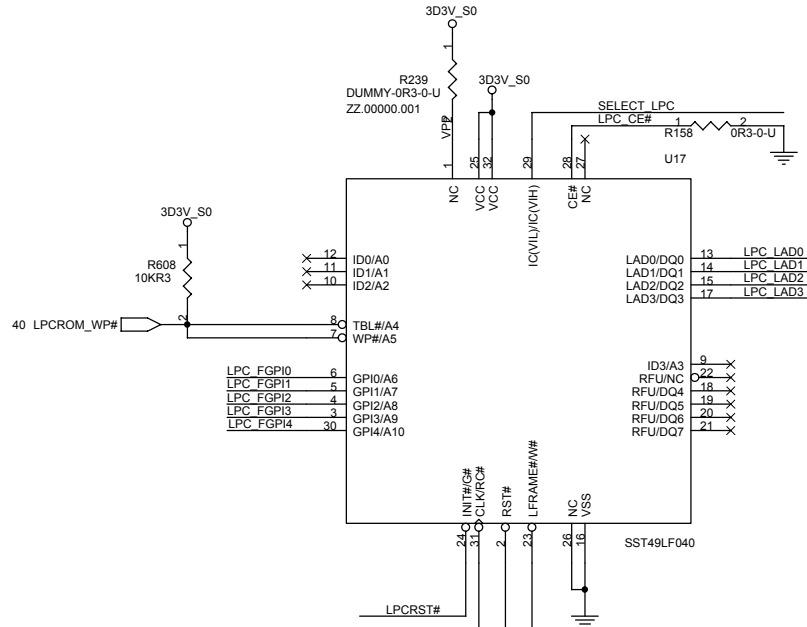
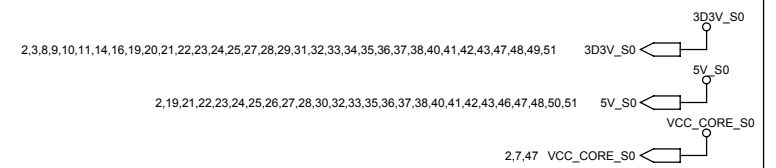
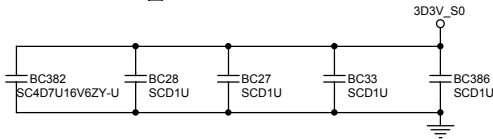

TOP VIEW

- A15 (B1)
- A14 (B2)
- ...
- A2 (B14)
- A1 (B15)

(BOTTOM VIEW)

GOLDEN FINGER FOR DEBUG BOARD

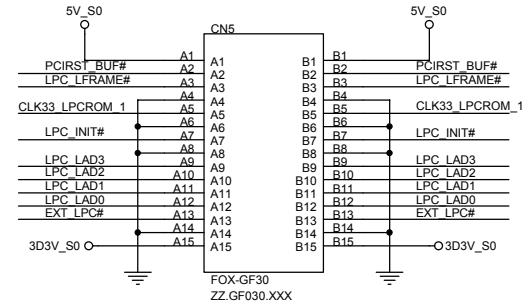

PLCC 32pin ST: 72.50040.003
 PLCC 32pin SST:
 72.49004.B03

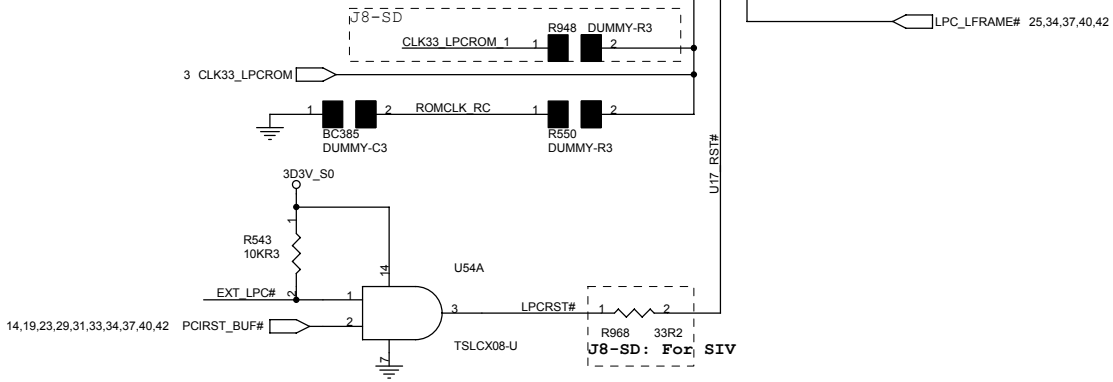

緯創資通 Wistron Corporation
 21F, 88, Sec.1, Hsin Tai Wj Rd., Hsichih,
 Taipei Hsien 221, Taiwan, R.O.C.

Title LPCROM / DEBUG PORT		
Size A3	Document Number Gannet	Rev -1
Date: Thursday, December 04, 2003 Sheet 39 of 51		

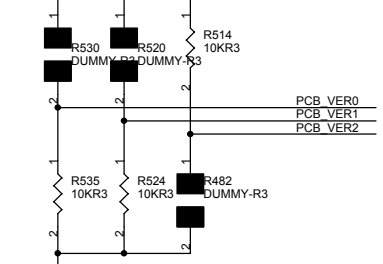
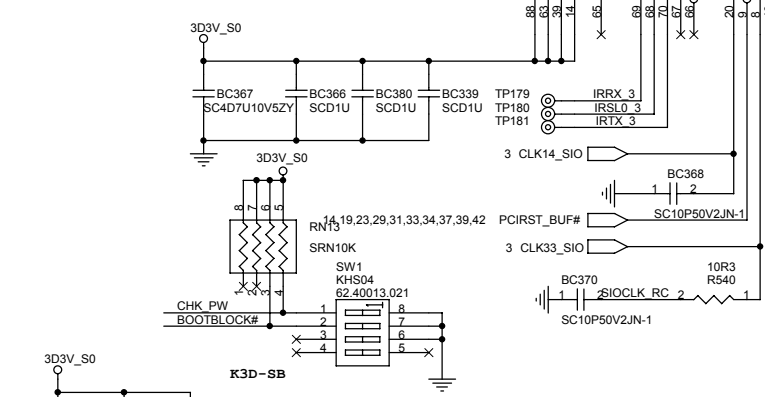
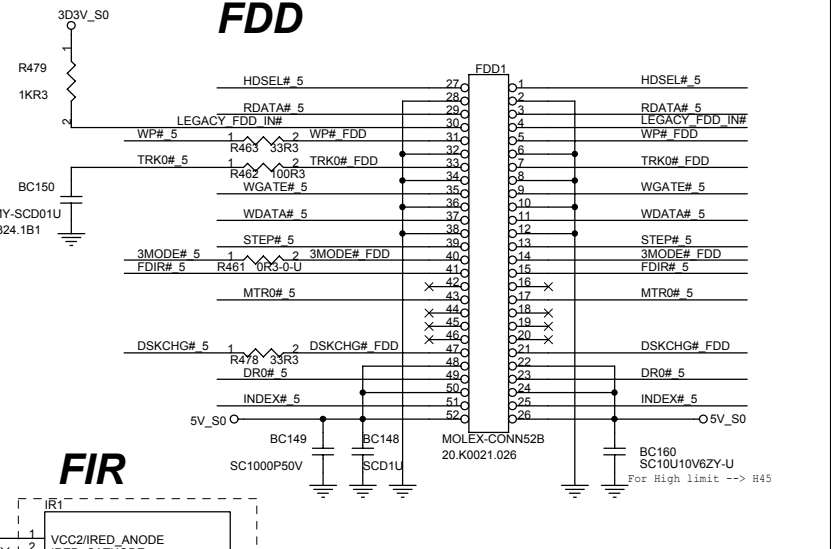
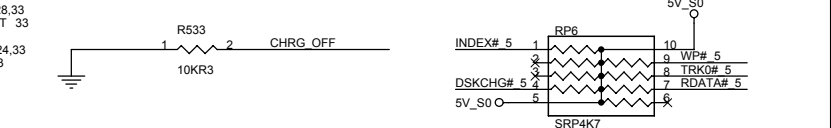
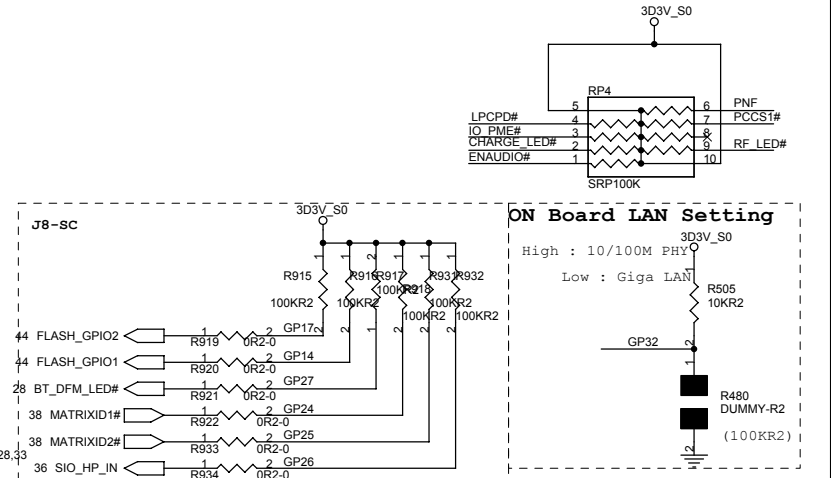
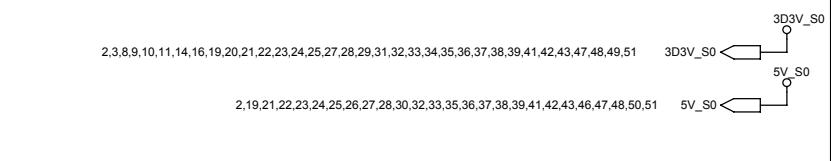
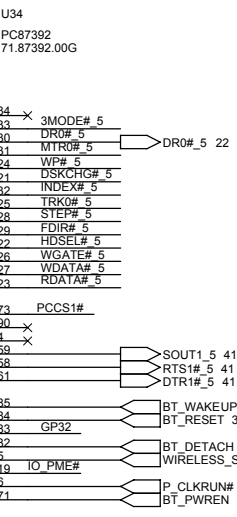
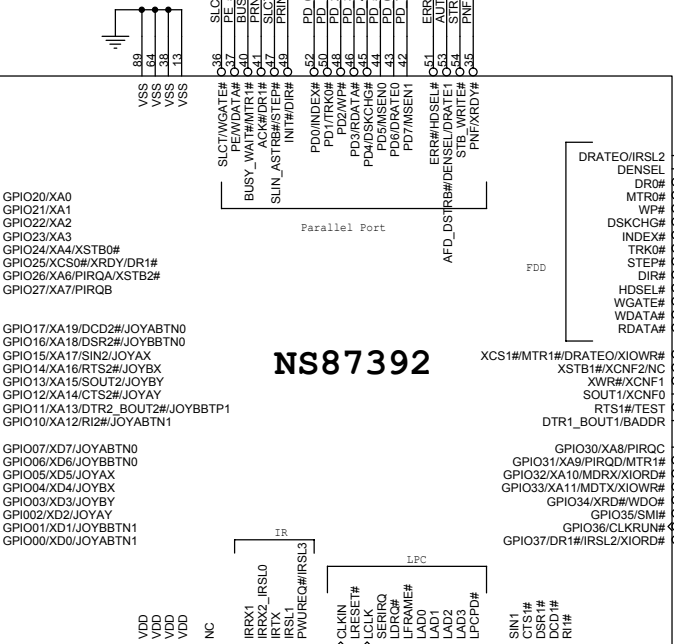
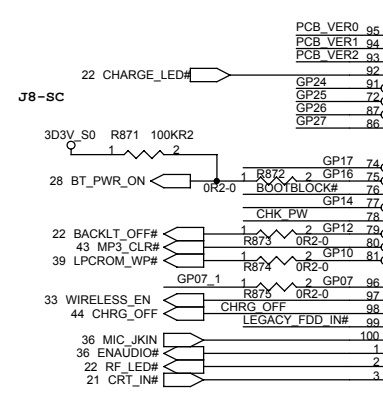
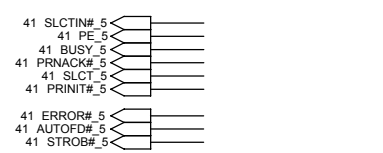
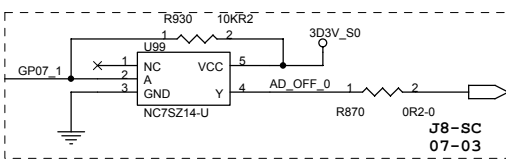

K3D Board Ver. Setting

Ver.	PCB_VER0	PCB_VER1	PCB_VER2
SA	0	1	1
SB	0	1	0
SC	1	1	0
SD	0	0	1
-1	1	0	1
-2	1	1	1

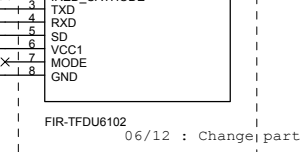
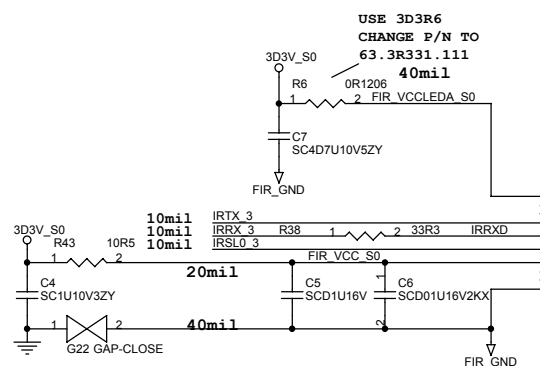

緯創資通 Wistron Corporation
 21F, 88, Sec.1, Hsin Tai Wd Rd., Hsichih, Taipei Hsien 221, Taiwan, R.O.C.

SUPER IO
 Document Number: Gannet
 Date: Thursday, December 04, 2003 Sheet 40 of 51

SERIAL PORT

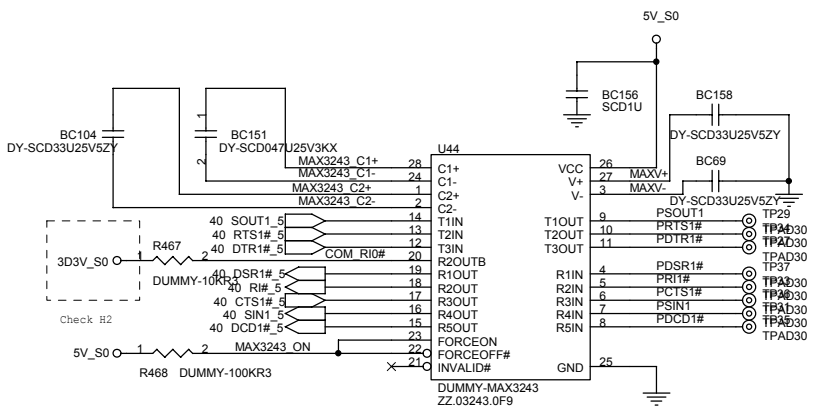

SA DV-3 Change MAX3243CDB TI to MAX3243 MAXIM

PRINTER PORT

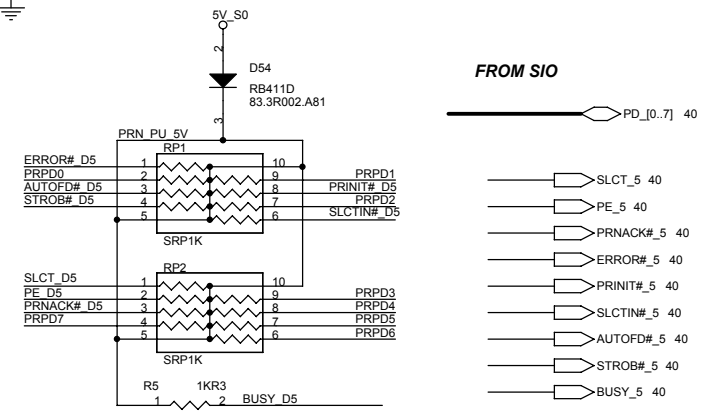
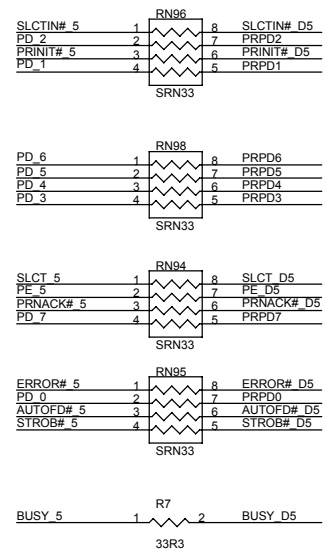
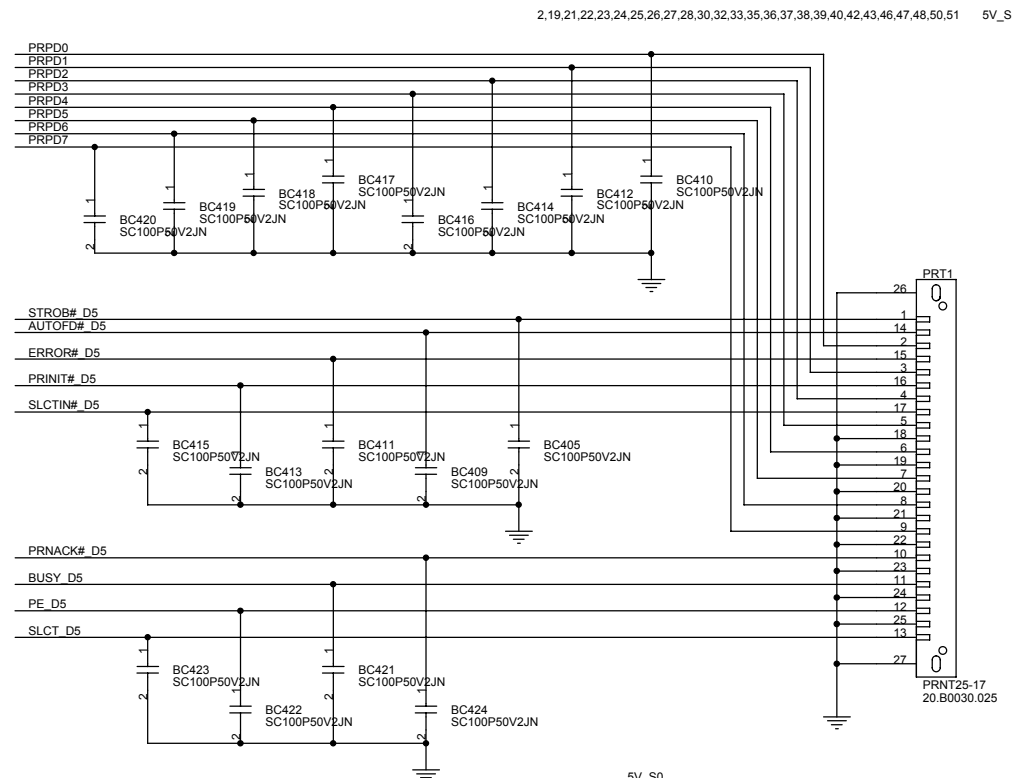

CHECK PULL HIGH

緯創資通 Wistron Corporation
21F, 88, Sec. 1, Hsin Tai Wu Rd., Hsichih, Taipei Hsien 221, Taiwan, R.O.C.

Title		PORTS	
Size	A3	Document Number	Gannet
Date:	Thursday, December 04, 2003	Sheet	41 of 51
Rev	-1		

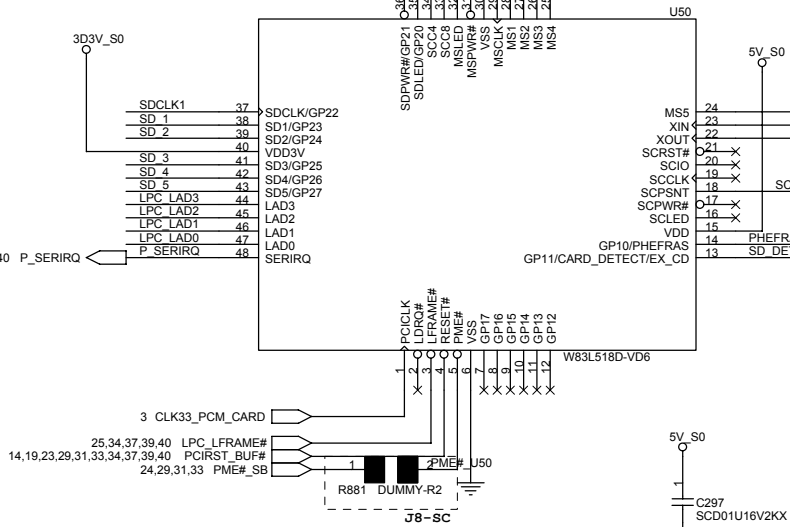
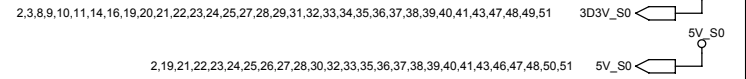
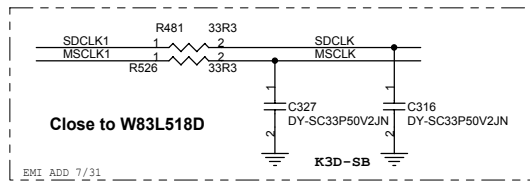
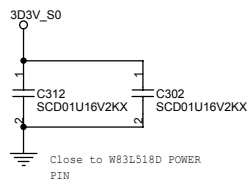

Close to W83L518D

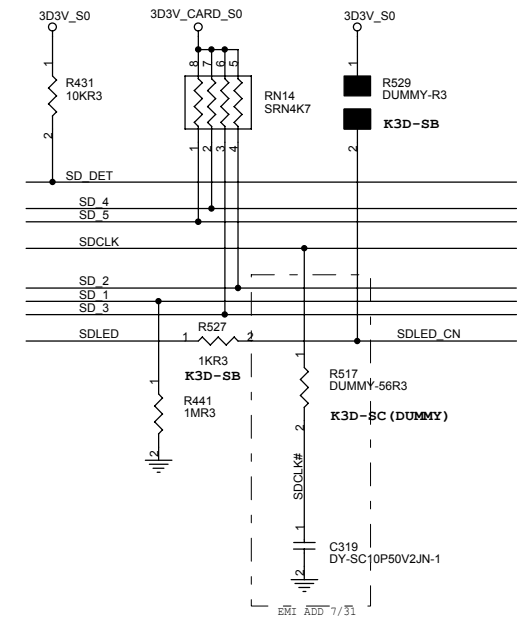
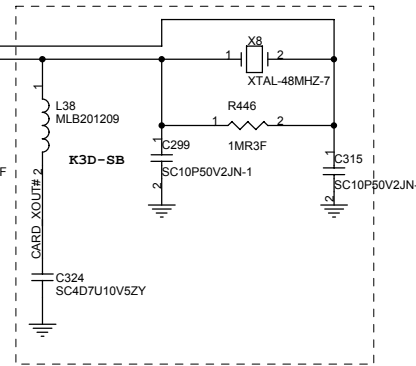

25,34,37,39,40 LPC_LAD[0..3]

Pull-low : Addr - 4E h
PHEFRAS
ref schematics is 4.7k
R432 10KR3

For SD/MS Card Power

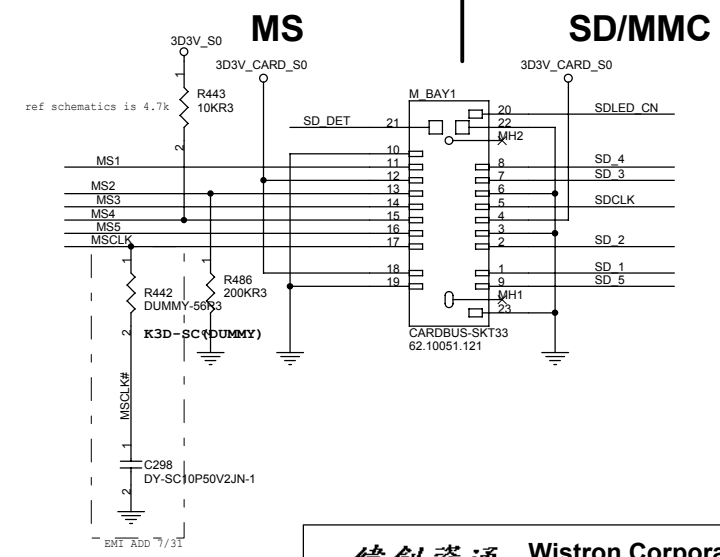
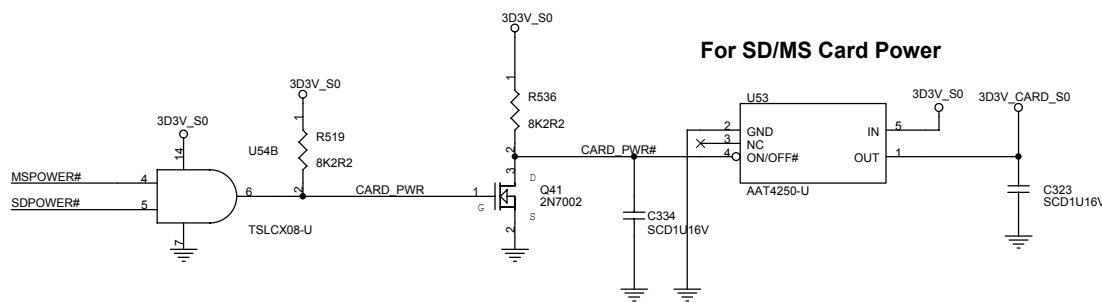

緯創資通 Wistron Corporation
21F, 88, Sec.1, Hsin Tai Wj Rd., Hsichih, Taipei Hsien 221, Taiwan, R.O.C.

Title: **CARD READER/MS/SD**

Size: A3	Document Number: Gannet	Rev: -1
----------	--------------------------------	---------

Date: Thursday, December 04, 2003 Sheet 42 of 51

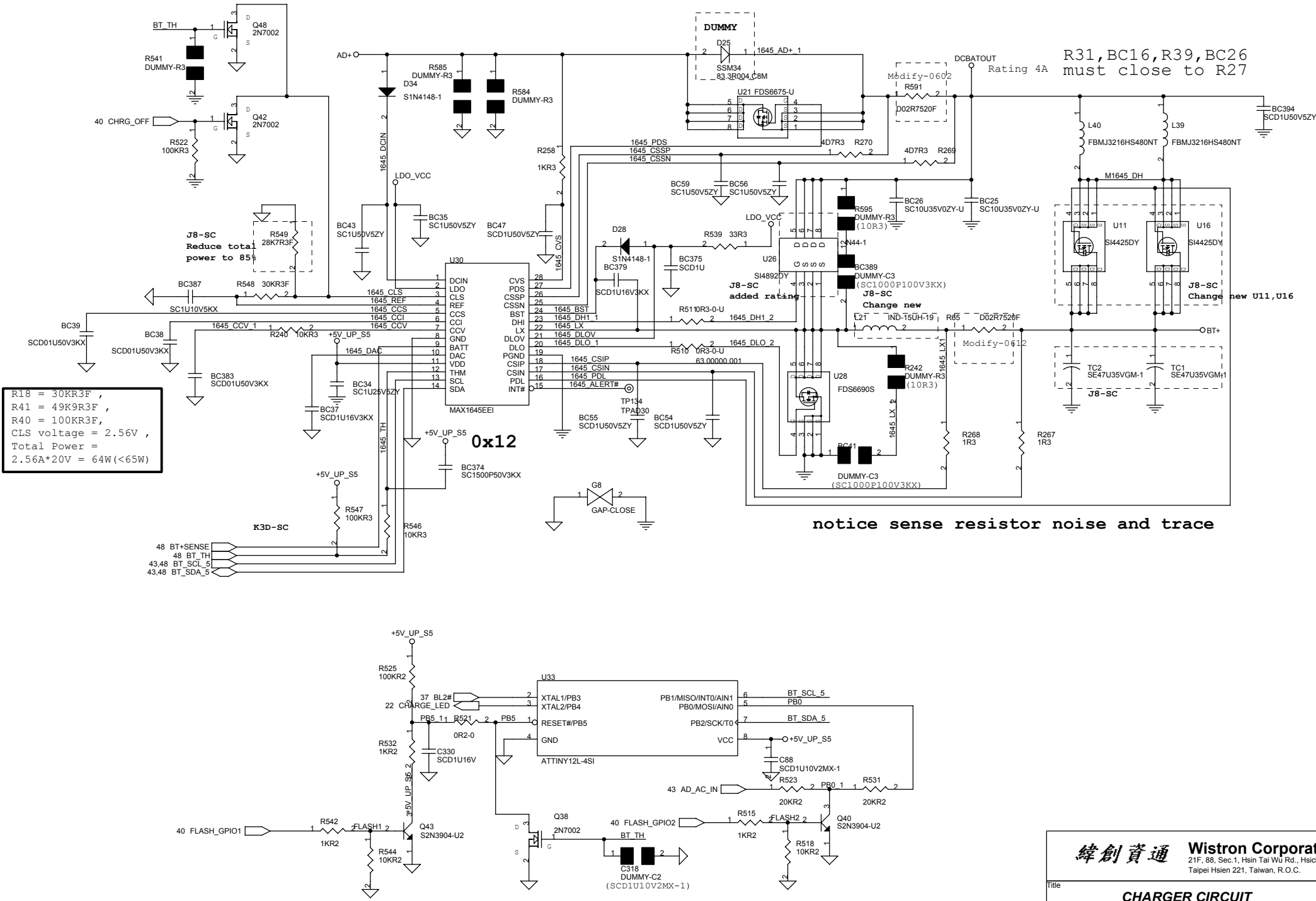

R18 = 30KR3F ,
 R41 = 49K9R3F ,
 R40 = 100KR3F ,
 CLS voltage = 2.56V ,
 Total Power =
 2.56A*20V = 64W (<65W)

0x12

notice sense resistor noise and trace

R31, BC16, R39, BC26 must close to R27

緯創資通 Wistron Corporation
 21F, 88, Sec.1, Hsin Tai Wj Rd., Hsichih,
 Taipei Hsien 221, Taiwan, R.O.C.

Title		
CHARGER CIRCUIT		
Size	Document Number	Rev
A3	Gannet	-1
Date: Thursday, December 04, 2003		
Sheet 44		of 51

SYSTEM DC/DC

3D3V_S5/5V_S5/1D5V_S5/UP+5V

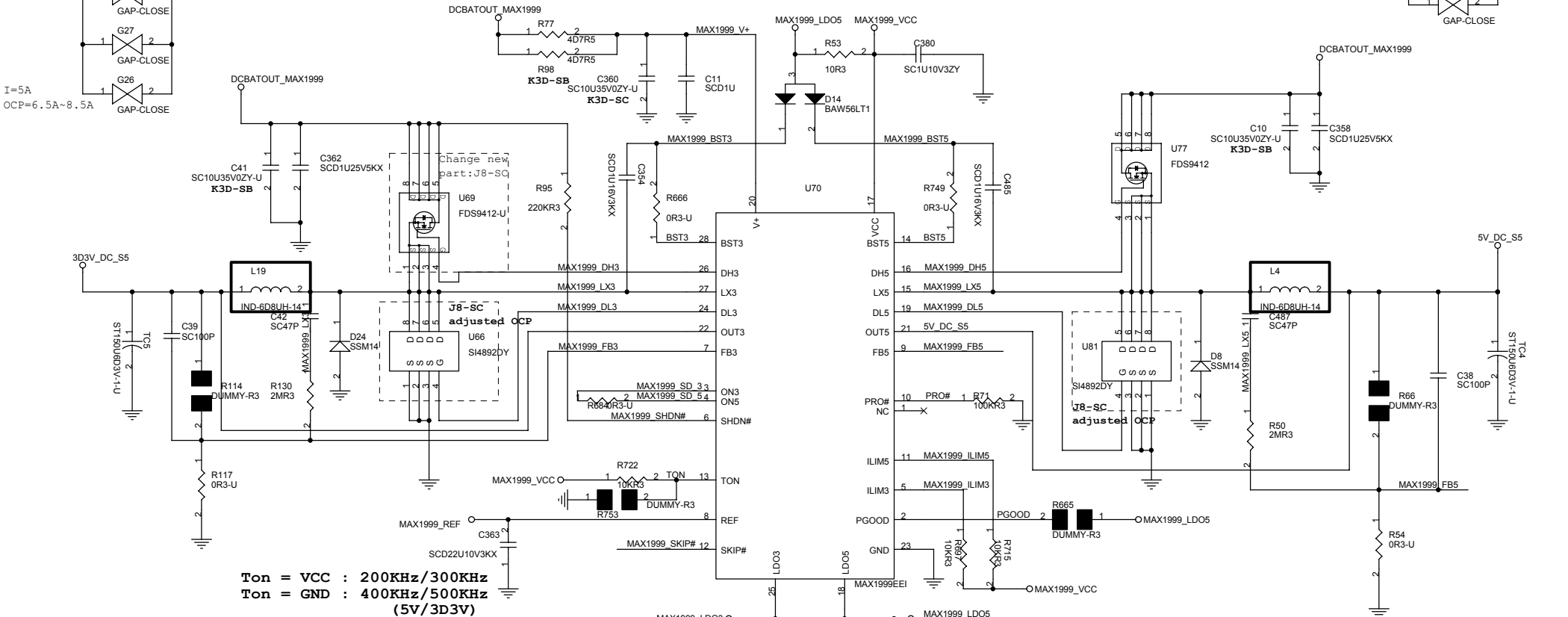
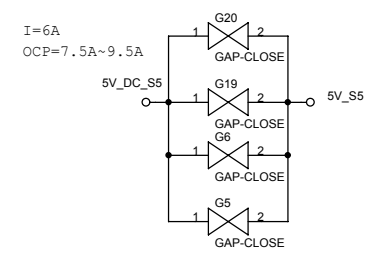
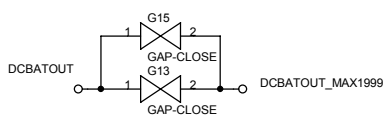
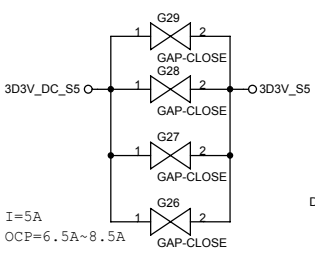

Ton = VCC : 200KHz/300KHz
Ton = GND : 400KHz/500KHz
(5V/3D3V)

100mA MAX.
100mA MAX.

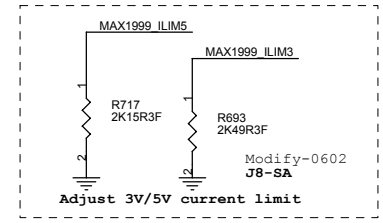
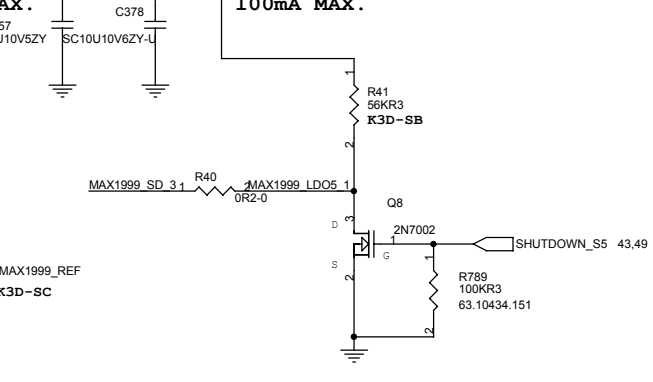
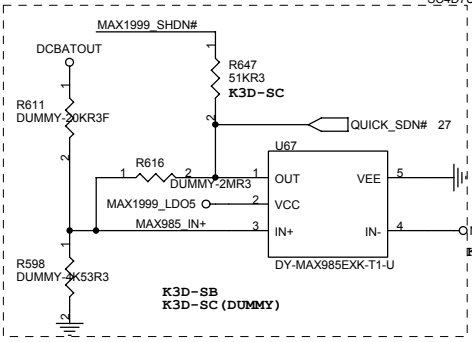
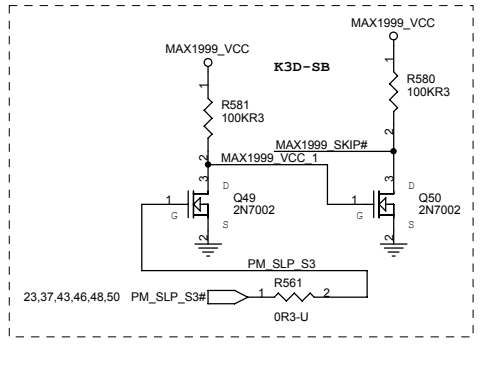

緯創資通 Wistron Corporation
 21F, 88, Sec.1, Hsin Tai Wu Rd., Hsichih, Taipei Hsien 221, Taiwan, R.O.C.

Title		
MAX1999/3D3V_S5/5V_S5		
Size	Document Number	Rev
A3		-1
Gannet		
Date: Thursday, December 04, 2003	Sheet 45	of 51

VGAPOWER / 1D25V_S0 / Charger Connector

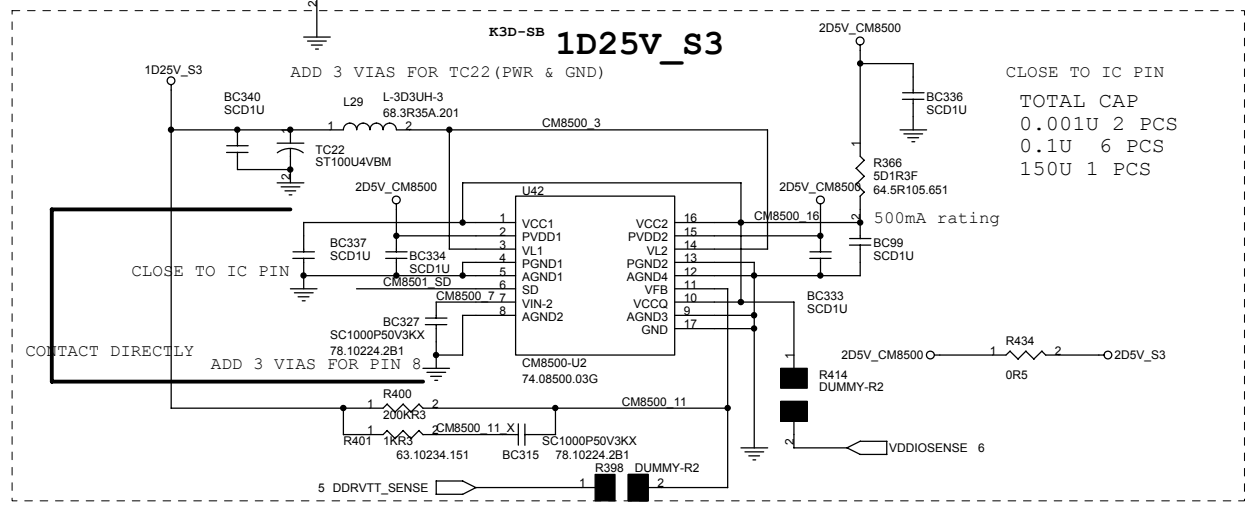
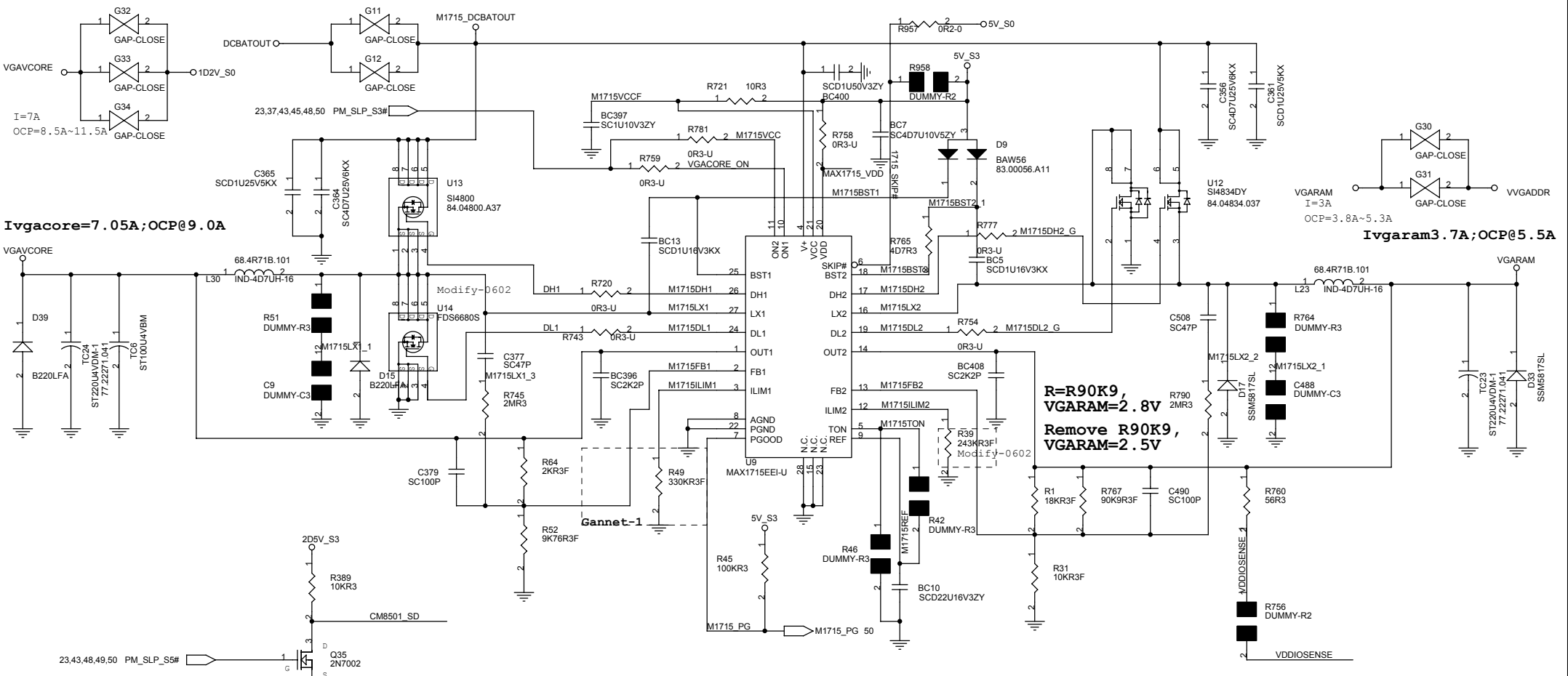

CLOSE TO IC PIN
TOTAL CAP
0.001U 2 PCS
0.1U 6 PCS
150U 1 PCS

緯創資通 Wistron Corporation
21F, 88, Sec.1, Hsin Tai Wu Rd., Hsichih, Taipei Hsien 221, Taiwan, R.O.C.

Title: **VGAPOWER / 1D25V_S3**

Size: A3 Document Number: **Gannet** Rev: -1

Date: Thursday, December 04, 2003 Sheet: 46 of 51

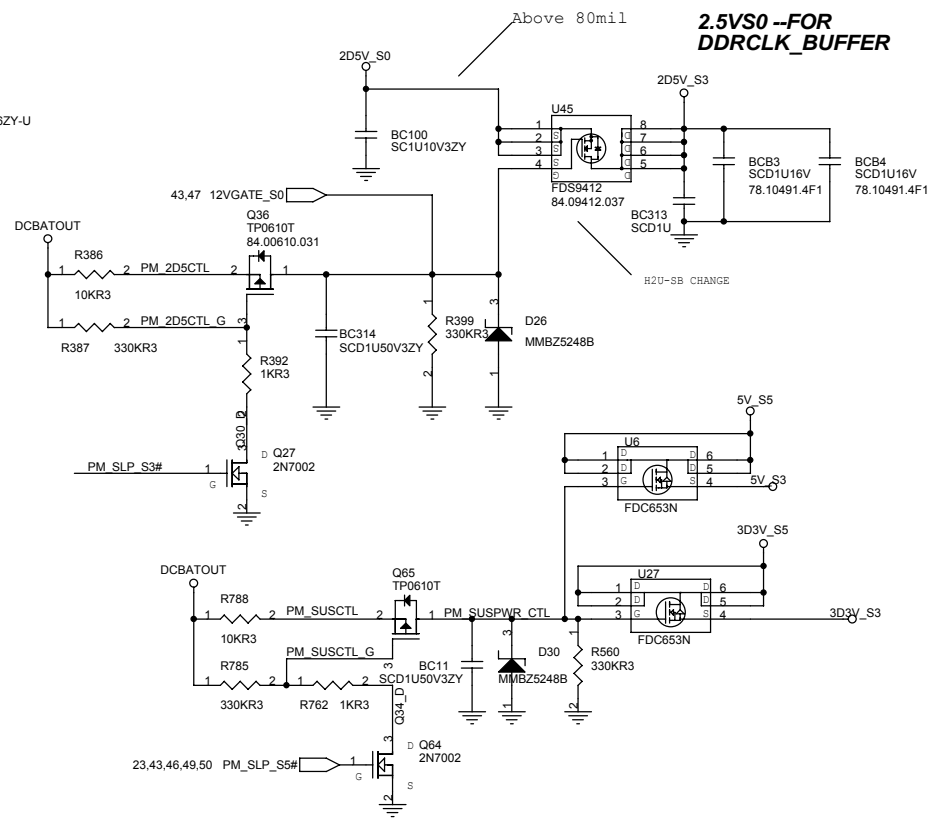
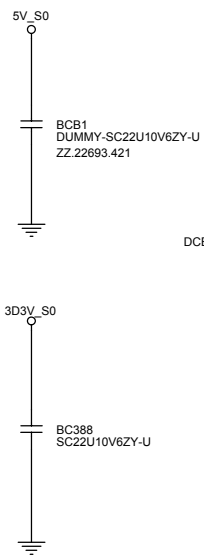
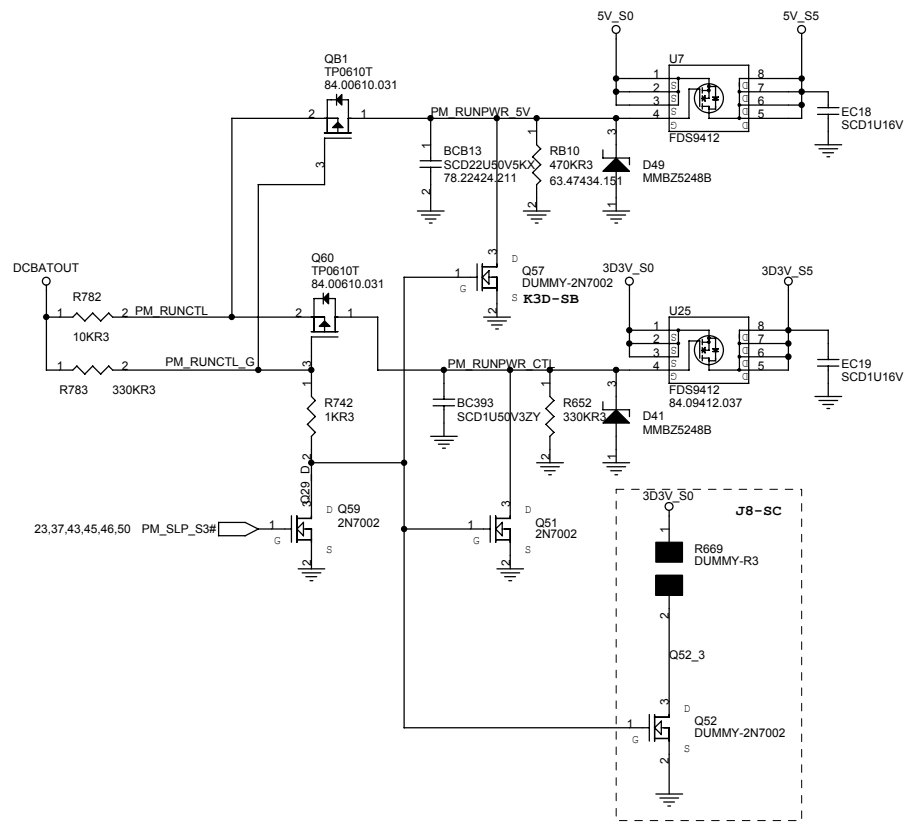

Charger CONN

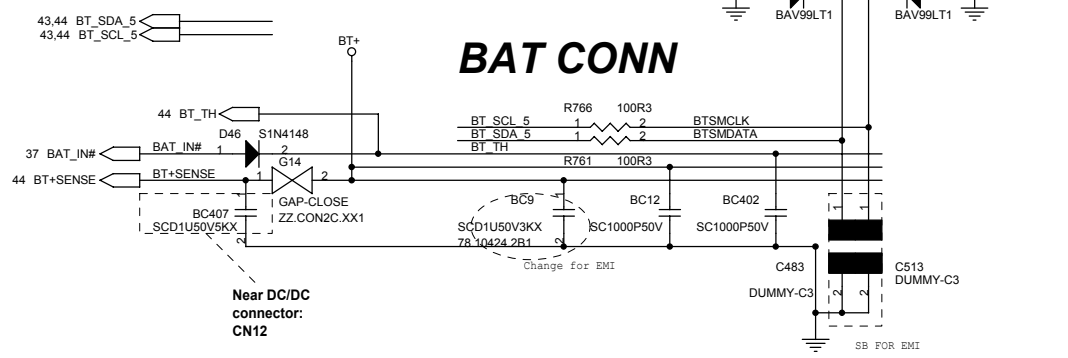
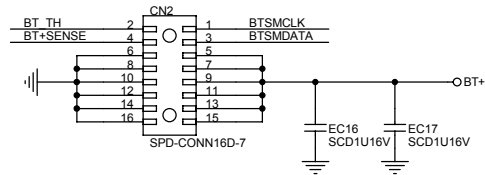

DC/DC (2/3) -- 2.5V /1.8V

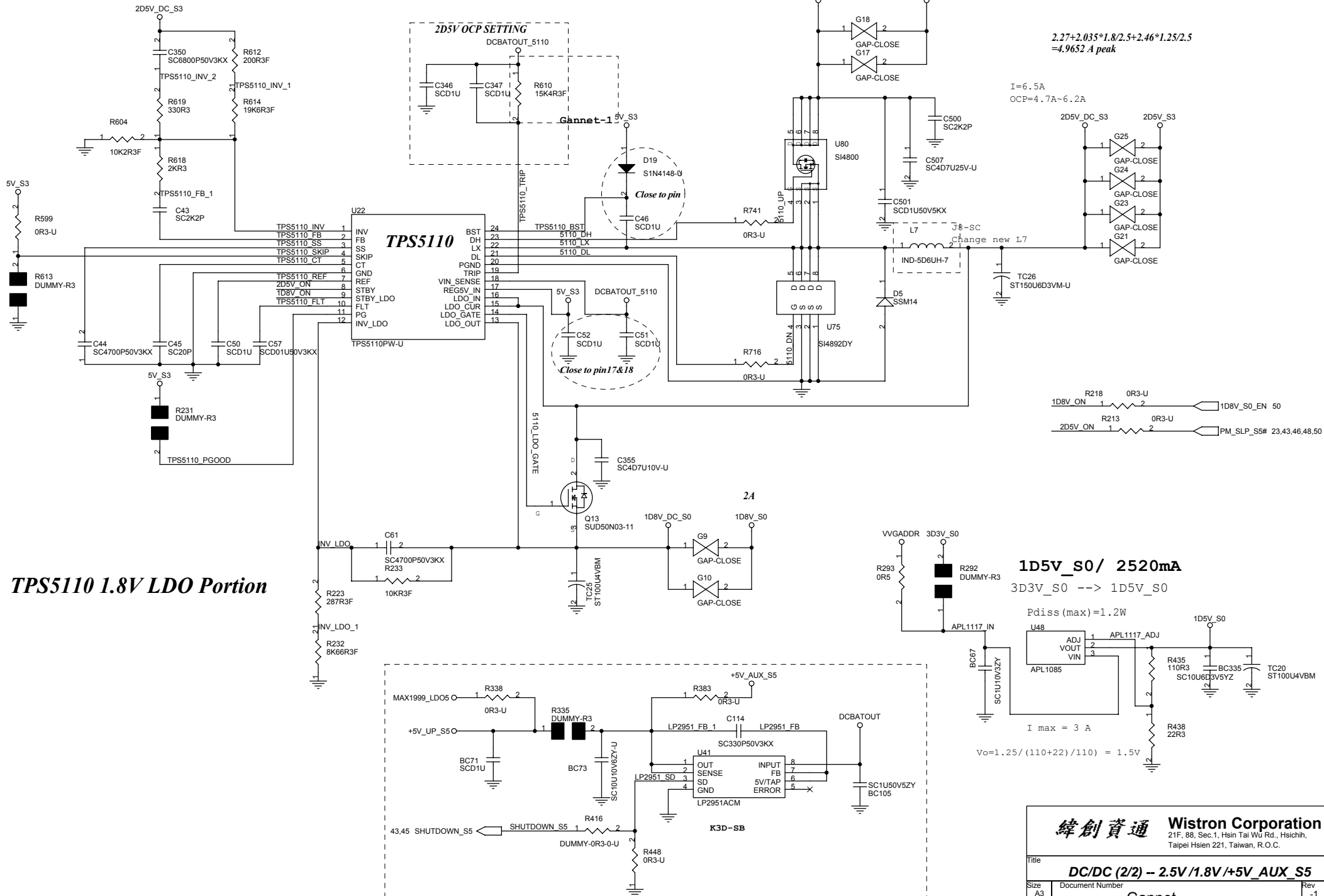

DC/DC:1D2V_S0

Current Limit : 1A

40Mils

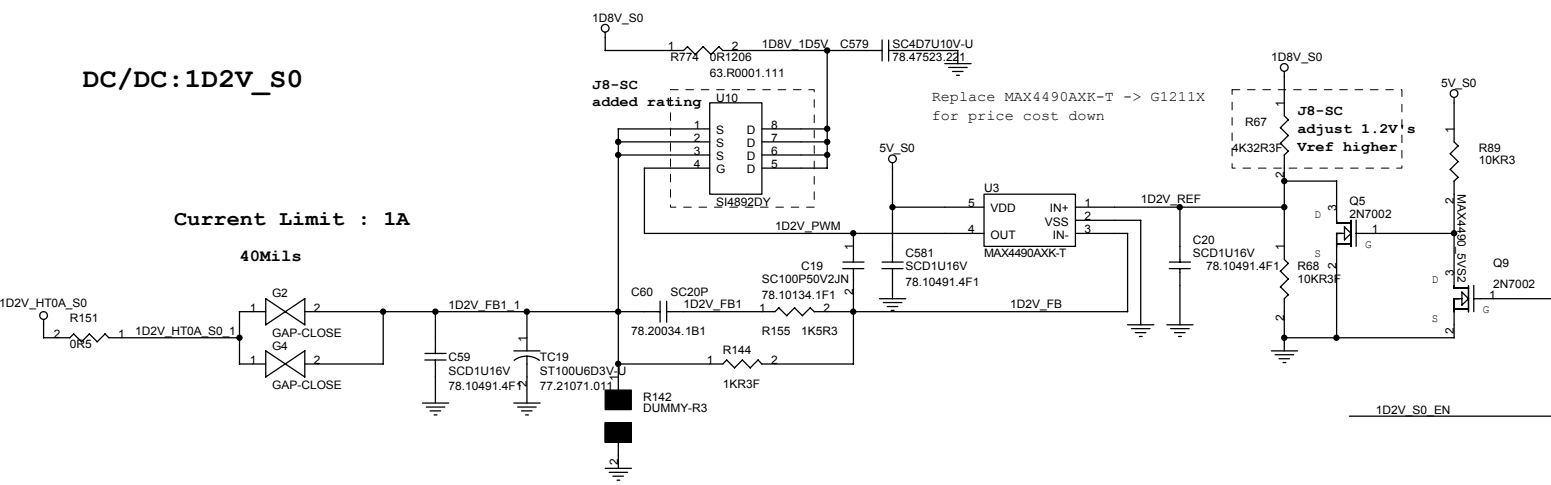

Replace MAX4490AXK-T -> G1211X for price cost down

J8-SC
adjust 1.2V₁s
Vref higher

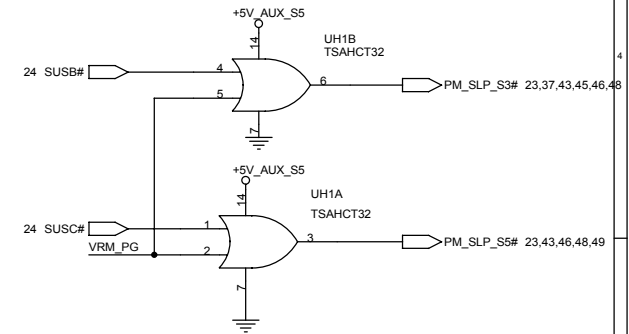

For CPU power off sequence

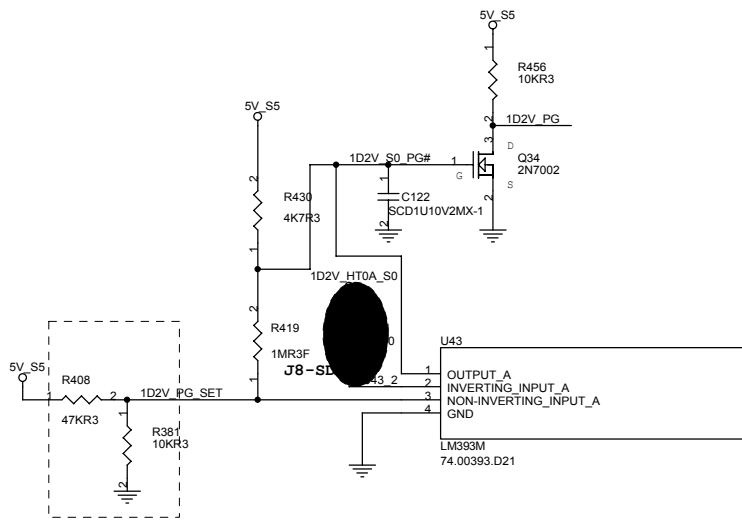
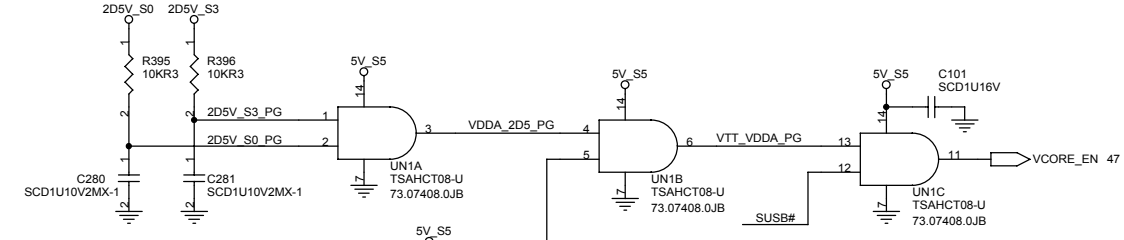

SB change R583 from 470KR3 to 47KR3, R584 from 100KR3 to 10KR3

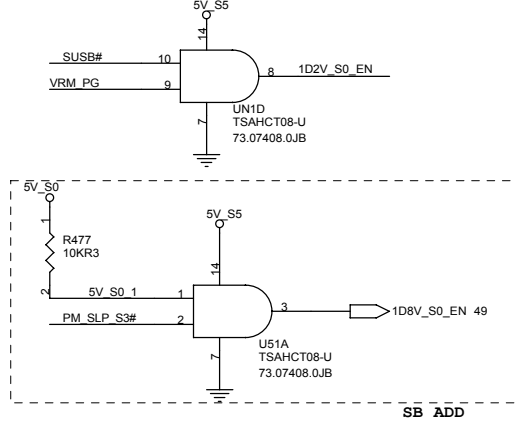
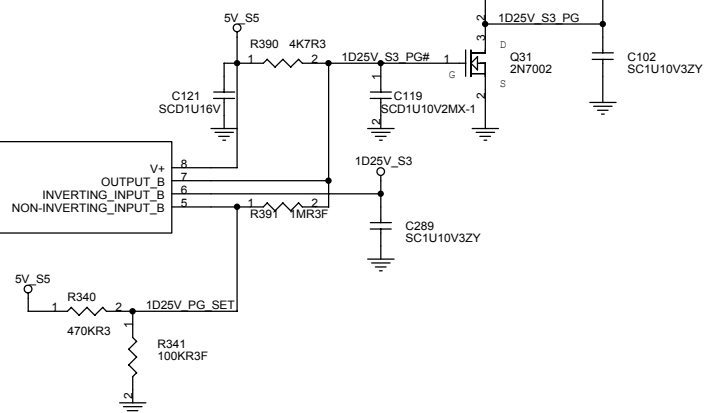

SB ADD

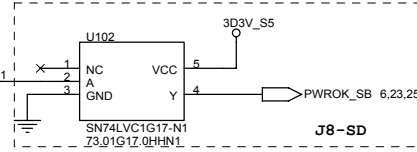
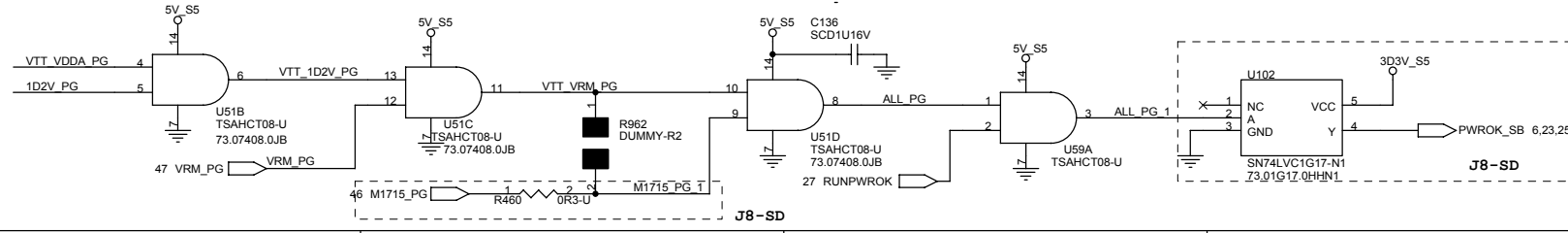

Wistron Corporation 21F, 88, Sec.1, Hsin Tai Wu Rd., Hsichih, Taipei Hsien 221, Taiwan, R.O.C.	
POWERGOOD&ENABLES	
Size	Document Number
Custom	Gannet
Date: Thursday, December 04, 2003	Sheet 50 of 51

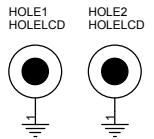
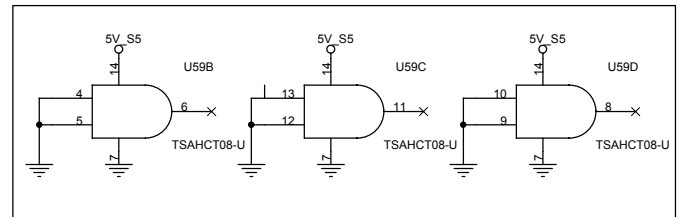
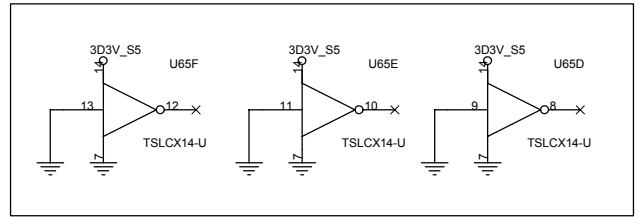
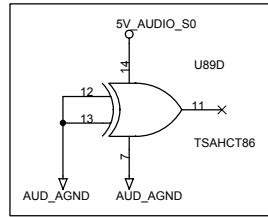
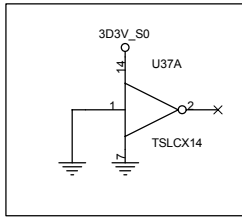
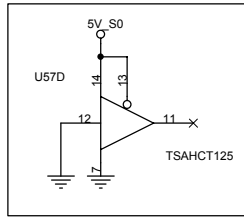
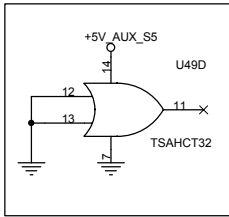
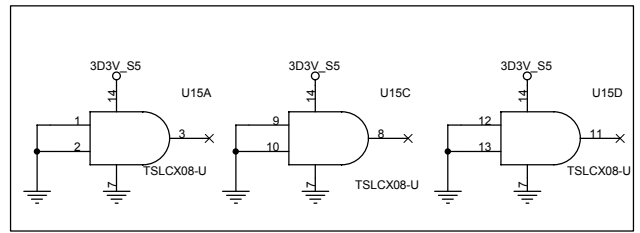
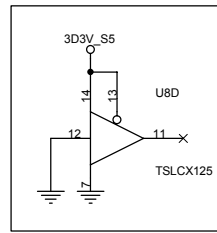
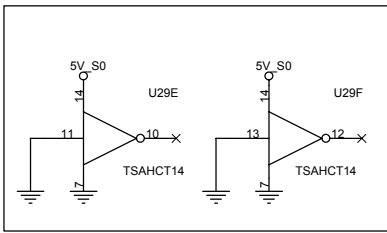
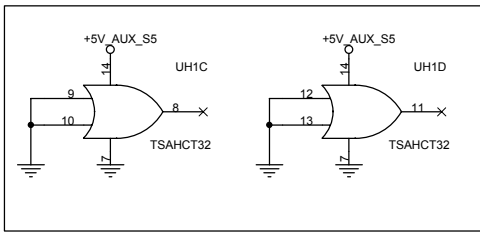

MDC Stand Off
P/N:
34.41Q08.001



LCD Stand Off
P/N:
34.41T01.001



DC/DC Stand Off
P/N:
34.41T02.001

SPARE GATES

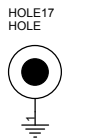

S3:34.42P26.001



S1:34.39S03.001



34.42P26.001

J8-SD
MODIFY
BY EMI.



34.42P26.001



ZZ_NDPAD.XXX

J8-SD
MODIFY BY EMI



ZZ_NDPAD.XXX

緯創資通 Wistron Corporation
21F, 88, Sec.1, Hsin Tai Wj Rd., Hsichih,
Taippei Hsien 221, Taiwan, R.O.C.

Title MISC		
Size A3	Document Number Gannet	Rev -1
Date: Thursday, December 04, 2003 Sheet 51 of 51		