

M9F/J BLOCK DIAGRAM

Content

01. Block Diagram & Content
02. Yonah - Host
03. Yonah - Power/GND
04. Clock Gen - ICS954310CGLFT
05. Thermal Sensor & Fan
06. Calistoga - Host
07. Calistoga - DMI
08. Calistoga - PCIE
09. Calistoga - SysMEM
10. Calistoga - Power-1
11. Calistoga - Power-2
12. Calistoga - GND
13. DDR2 Onboard CHA-1
14. DDR2 Onboard CHA-2
15. DDR2 Slot CHB
16. DDR2 Termination
17. G72M-V - PCIE
18. G72M-V - FB I/F
19. G72M-V - VRAM1
20. G72M-V - VRAM2
21. G72M-V - LVDS
22. G72M-V - CRT/TV OUT
23. G72M-V - GPIO
24. G72M-V - STRAPING&GND
25. CRT & TV CON
26. LCD & INVERTER
27. ICH7M - Azalia/IDE/PM
28. ICH7M - PCI/PCI-E/USB
29. ICH7M - Power/GND
30. KBC - M38857
31. Keyboard & Touchpad & LED
32. TPM & FWB & Debug
33. Audio DJ
34. HDD & ODD CON
35. USB
36. mini Card
37. Express Card
38. Gigabit Ethernet - RTL8111B
39. R5C832
40. 4-IN-1 Card & 1394a CON
41. Azalia Codec & Modem CON
42. Audio Amplifier & Depop
43. Audio Jack
44. Power Sequence
45. Power Discharge
46. DC-IN & BAT-IN
47. Screw Hole
48. Dummy
49. Dummy
50. POWER_VCORE
51. POWER_SYSTEM
52. POWER_I/O_1.5VO & 1.05VO
53. POWER_I/O_DDR & VTT
54. POWER_I/O_+3VAO & +2.5VS
55. POWER_VGA_CORE
56. POWER_VGA_+1.2VS
57. POWER_CHARGER
58. POWER_PIC
59. POWER_DETECT
60. POWER_PROTECT
61. POWER_LOAD SWITCH
62. POWER_FLOWCHART
63. POWER_SIGNAL

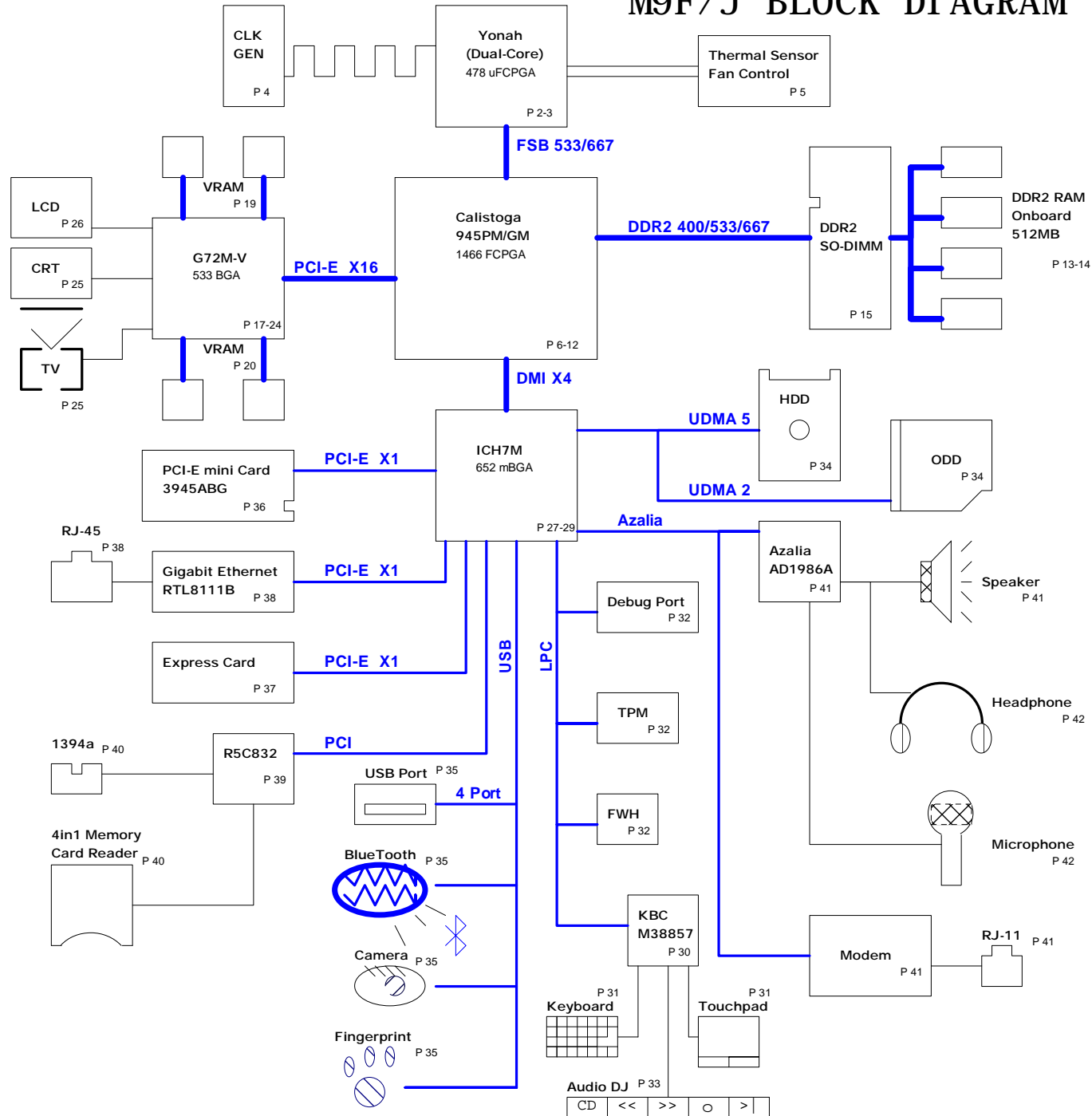

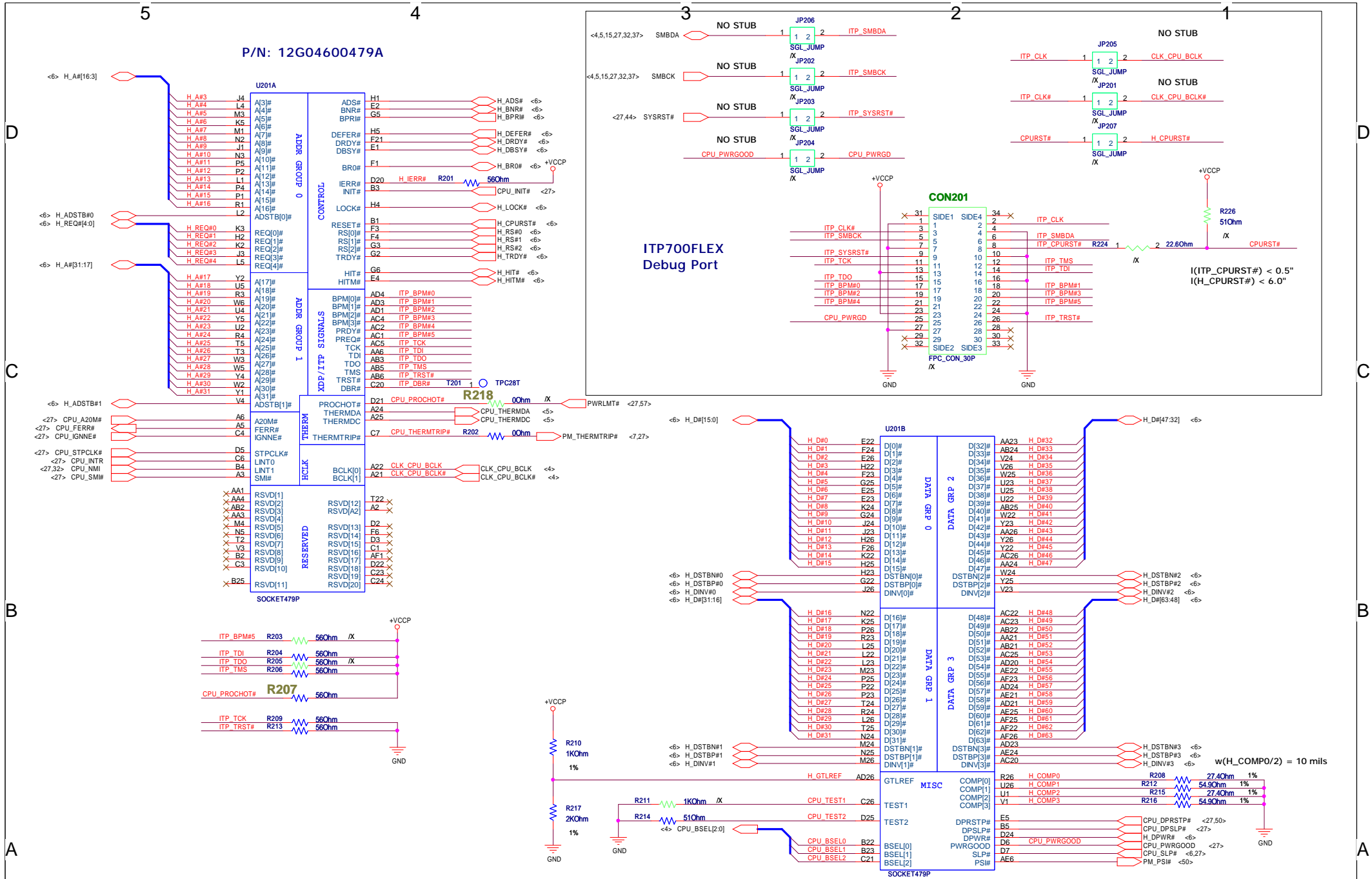

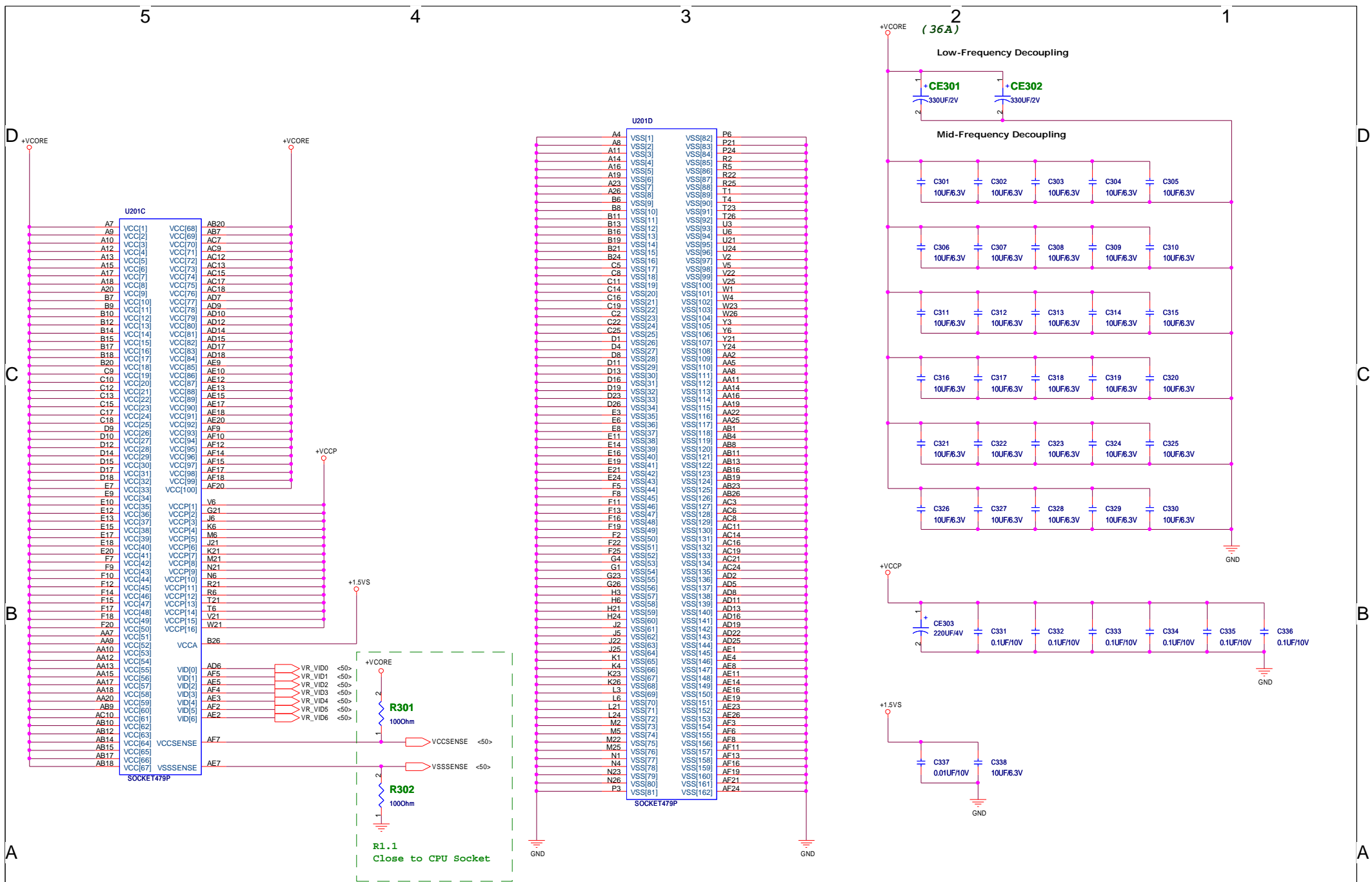

Bclk	FSB	FSLC	FSLB	FSLA
133	533	L	L	H
166	667	L	H	H

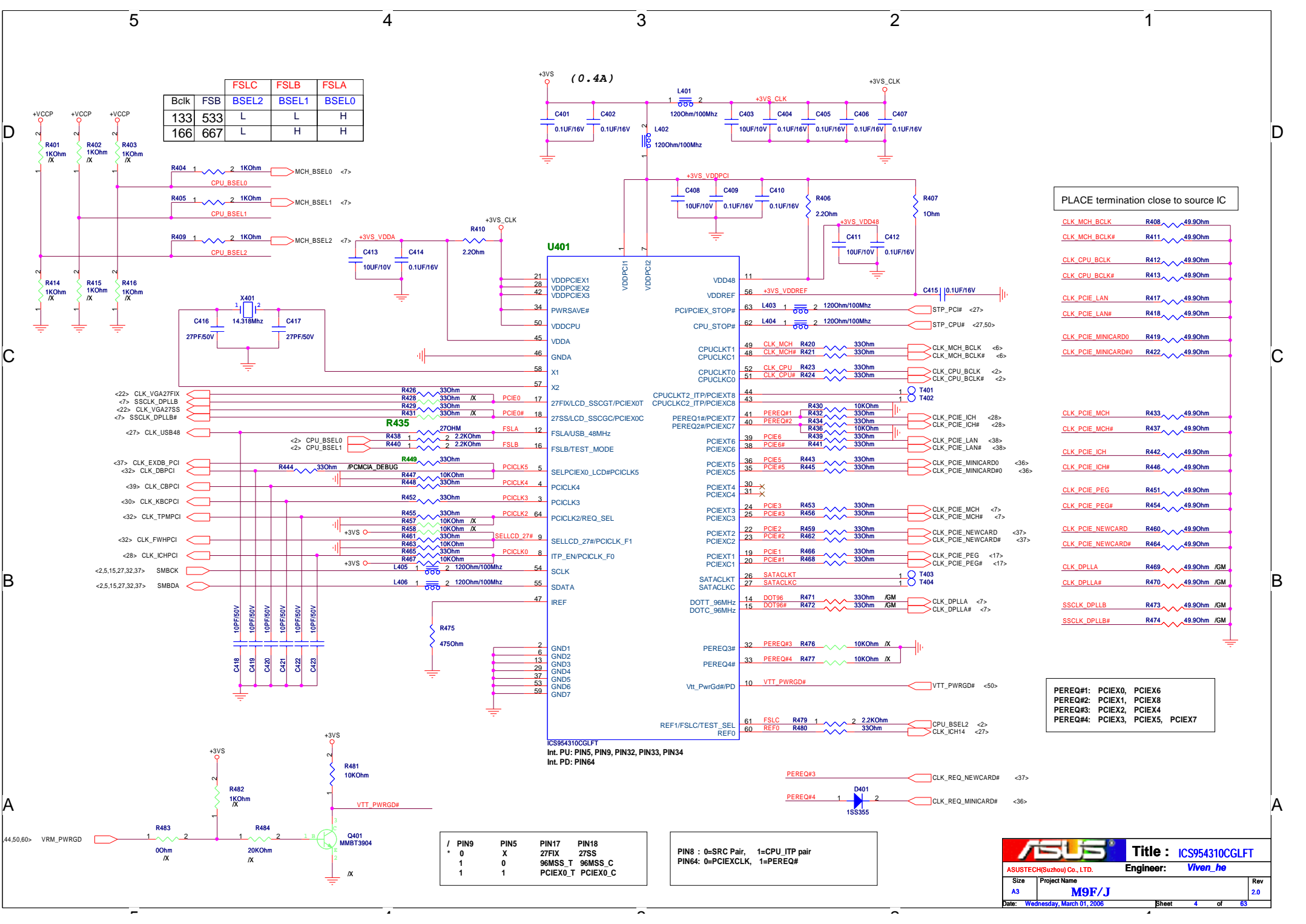

PLACE termination close to source IC

- CLK_MCH_BCLK R408 49.90hm
- CLK_MCH_BCLK# R411 49.90hm
- CLK_CPU_BCLK R412 49.90hm
- CLK_CPU_BCLK# R413 49.90hm
- CLK_PCIE_LAN R417 49.90hm
- CLK_PCIE_LAN# R418 49.90hm
- CLK_PCIE_MINICARD0 R419 49.90hm
- CLK_PCIE_MINICARD#0 R422 49.90hm
- CLK_PCIE_MCH R433 49.90hm
- CLK_PCIE_MCH# R437 49.90hm
- CLK_PCIE_ICH R442 49.90hm
- CLK_PCIE_ICH# R446 49.90hm
- CLK_PCIE_PEG R451 49.90hm
- CLK_PCIE_PEG# R454 49.90hm
- CLK_PCIE_NEWCARD R460 49.90hm
- CLK_PCIE_NEWCARD# R464 49.90hm
- CLK_DPLLA R469 49.90hm /GM
- CLK_DPLLA# R470 49.90hm /GM
- SSCLK_DPLL# R473 49.90hm /GM
- SSCLK_DPLL# R474 49.90hm /GM

- PEREQ#1: PCIEX0, PCIEX6
- PEREQ#2: PCIEX1, PCIEX8
- PEREQ#3: PCIEX2, PCIEX4
- PEREQ#4: PCIEX3, PCIEX5, PCIEX7

/	PIN9	PIN5	PIN17	PIN18
*	0	X	27FIX	27SS
	1	0	96MSS_T	96MSS_C
	1	1	PCIEX0_T	PCIEX0_C

PIN8 : 0=SRC Pair, 1=CPU_ITP pair
 PIN64: 0=PCIEXLCK, 1=PEREQ#

ASUS		Title : ICS954310CGLFT	
ASUSTECH(Suzhou) Co., LTD.		Engineer: Viven_he	
Size	Project Name	Rev	
A3	M9F/J	2.0	
Date: Wednesday, March 01, 2006		Sheet	4 of 63

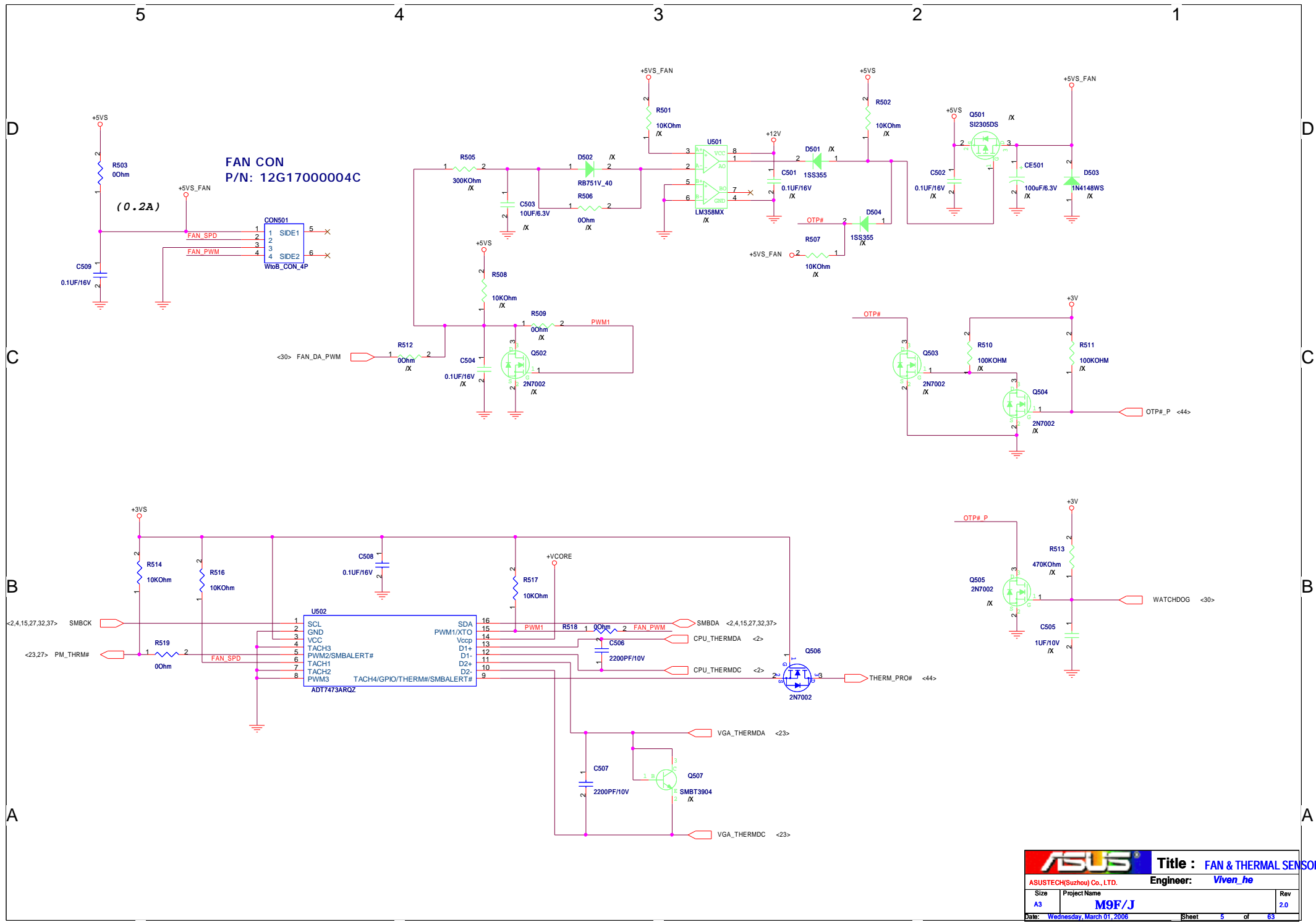

5

4

3

2

1

945PM P/N: 02G010009205
945GM P/N: 02G010009210

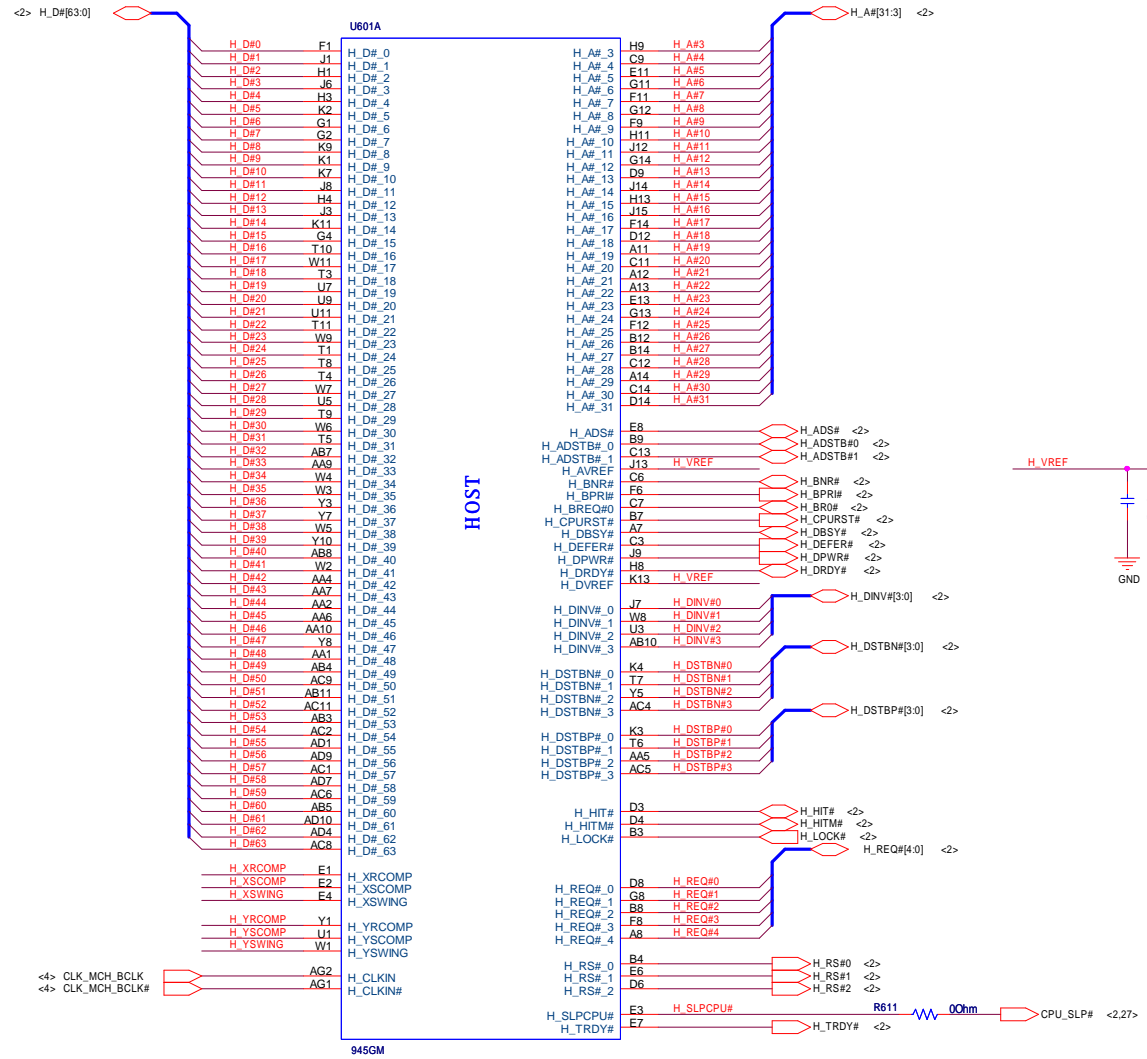

D

D

C

C

B

B

A

A

		Title : Calistoga - Host	
ASUSTECH(Suzhou) Co., Ltd.		Engineer: Pommy Lu	
Size A3	Project Name M9F/J	Rev 2.0	
Date: Wednesday, March 01, 2006		Sheet 6	of 63

5

4

3

2

1

STRAPPING CONFIGURATION
 CFG[17:3] - Internal pull-up
 CFG[20:18] - Internal pull-down

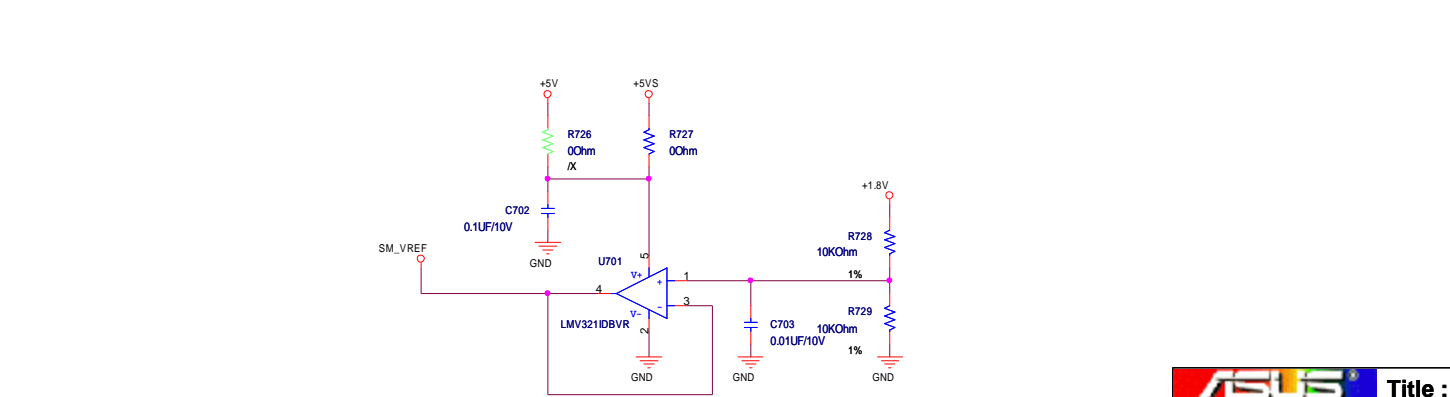
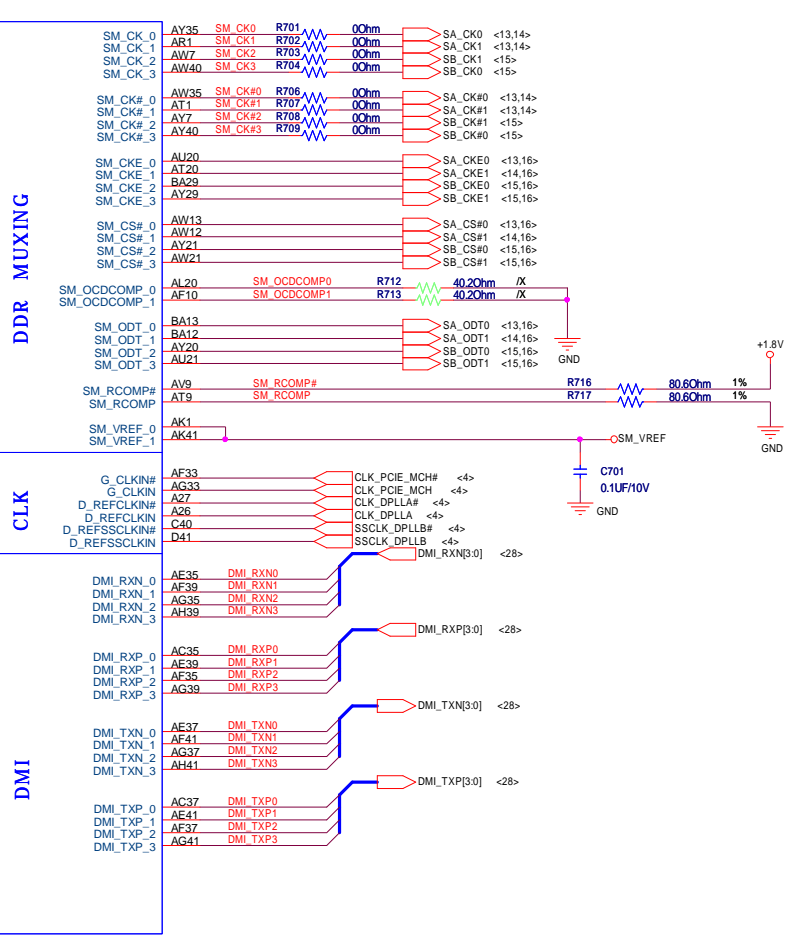
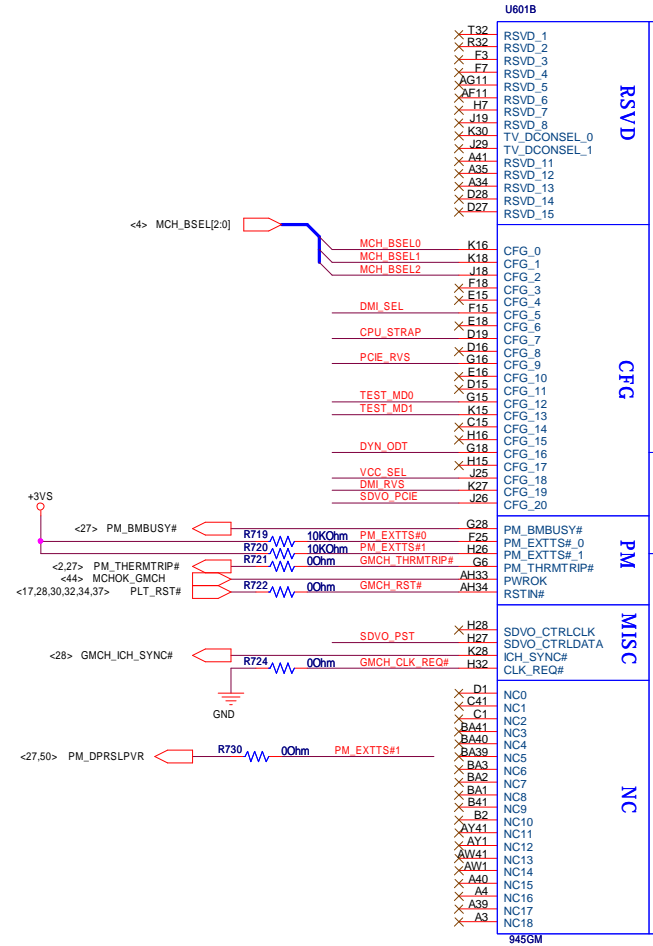
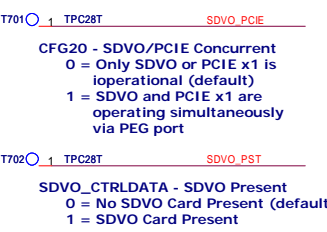
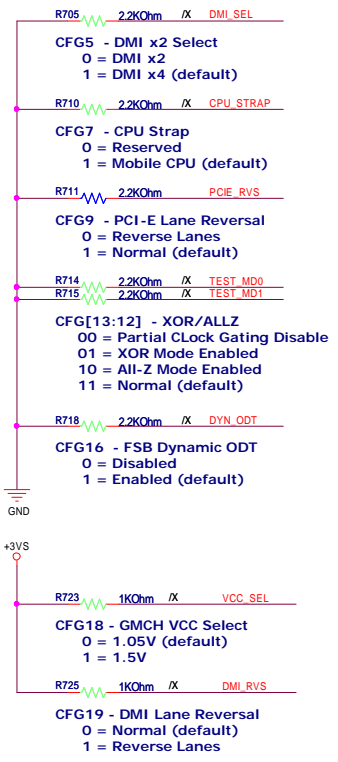

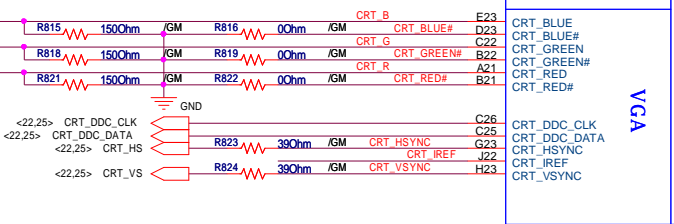
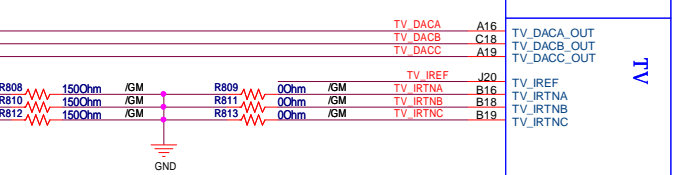
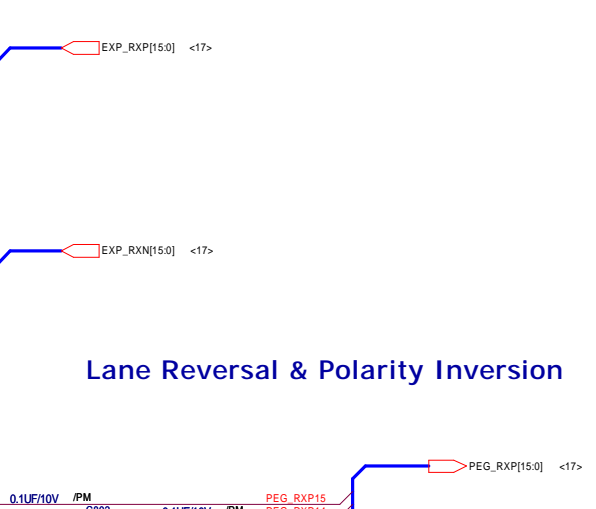
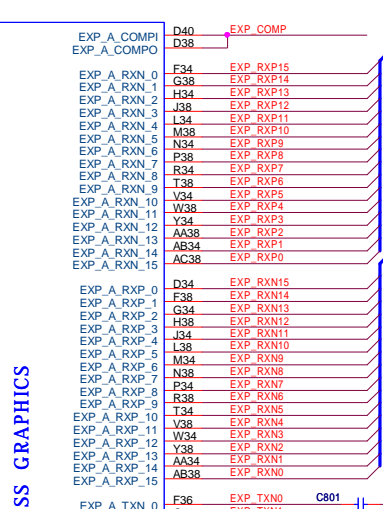
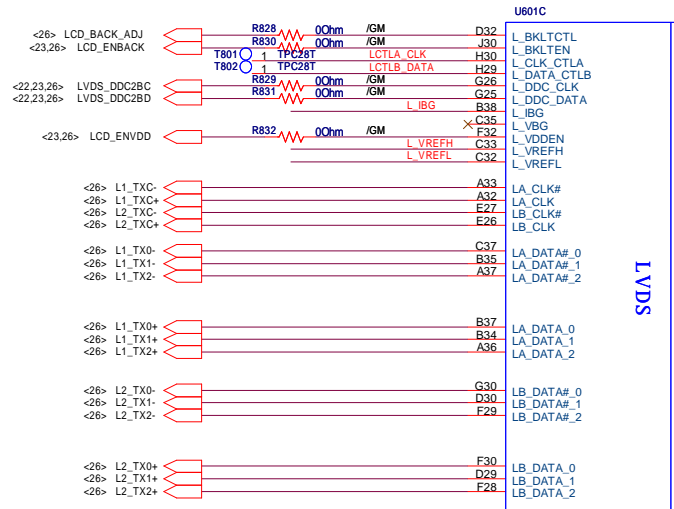
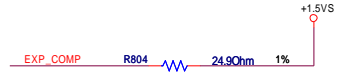
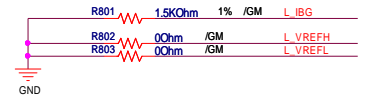

945GM

OPTIONAL
 /GM: mount when GMCH use 945GM
 /PM: mount when GMCH use 945PM

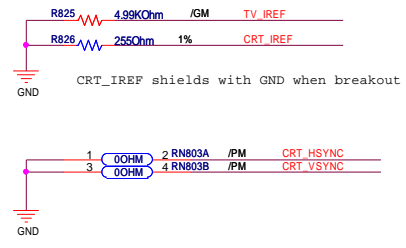
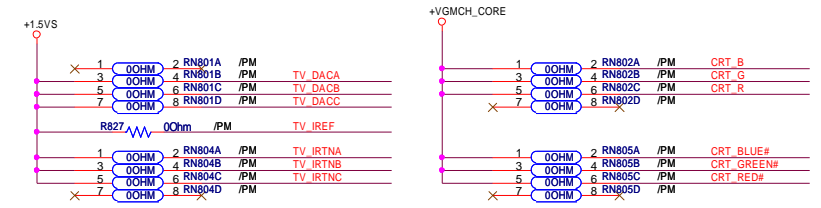

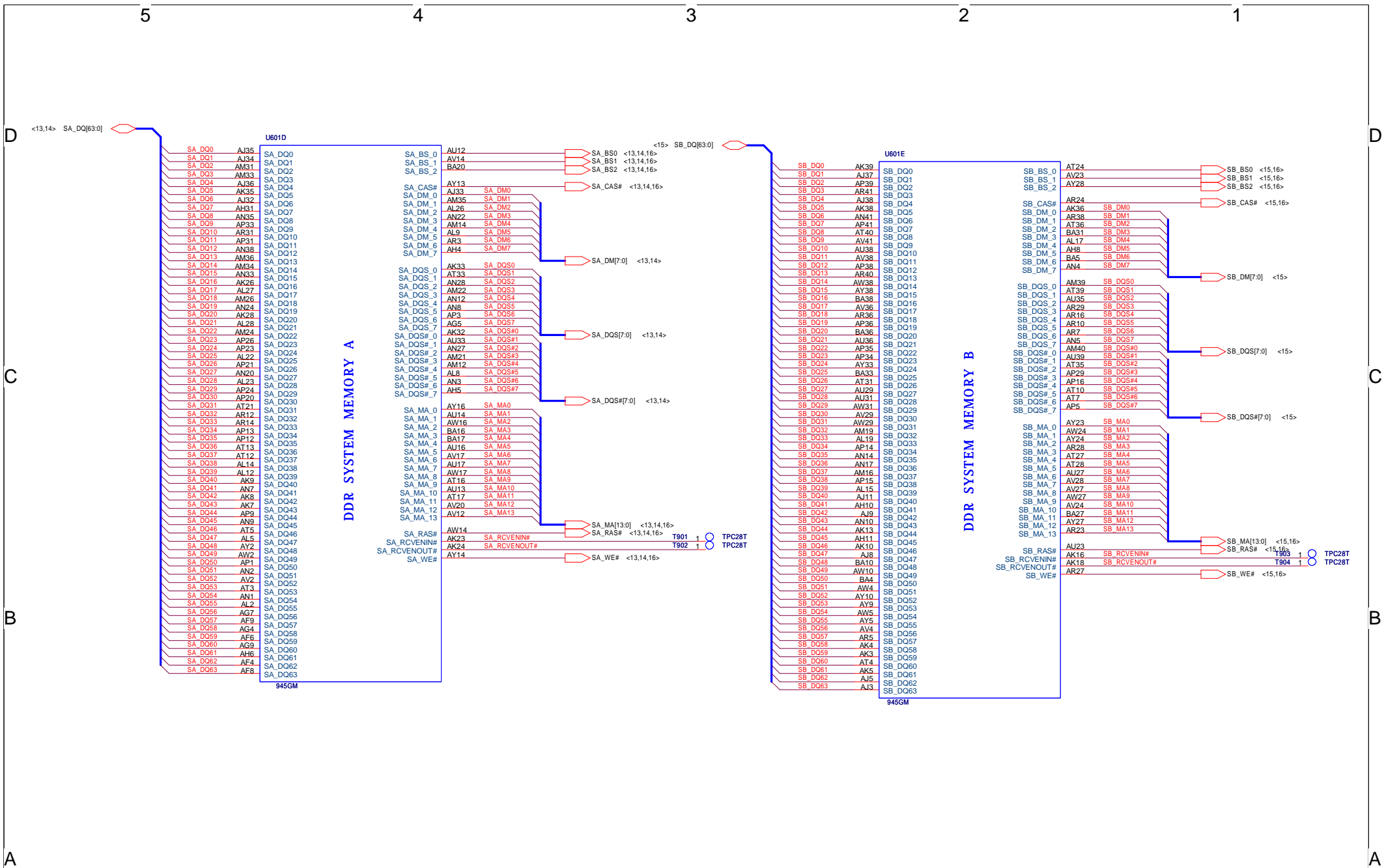

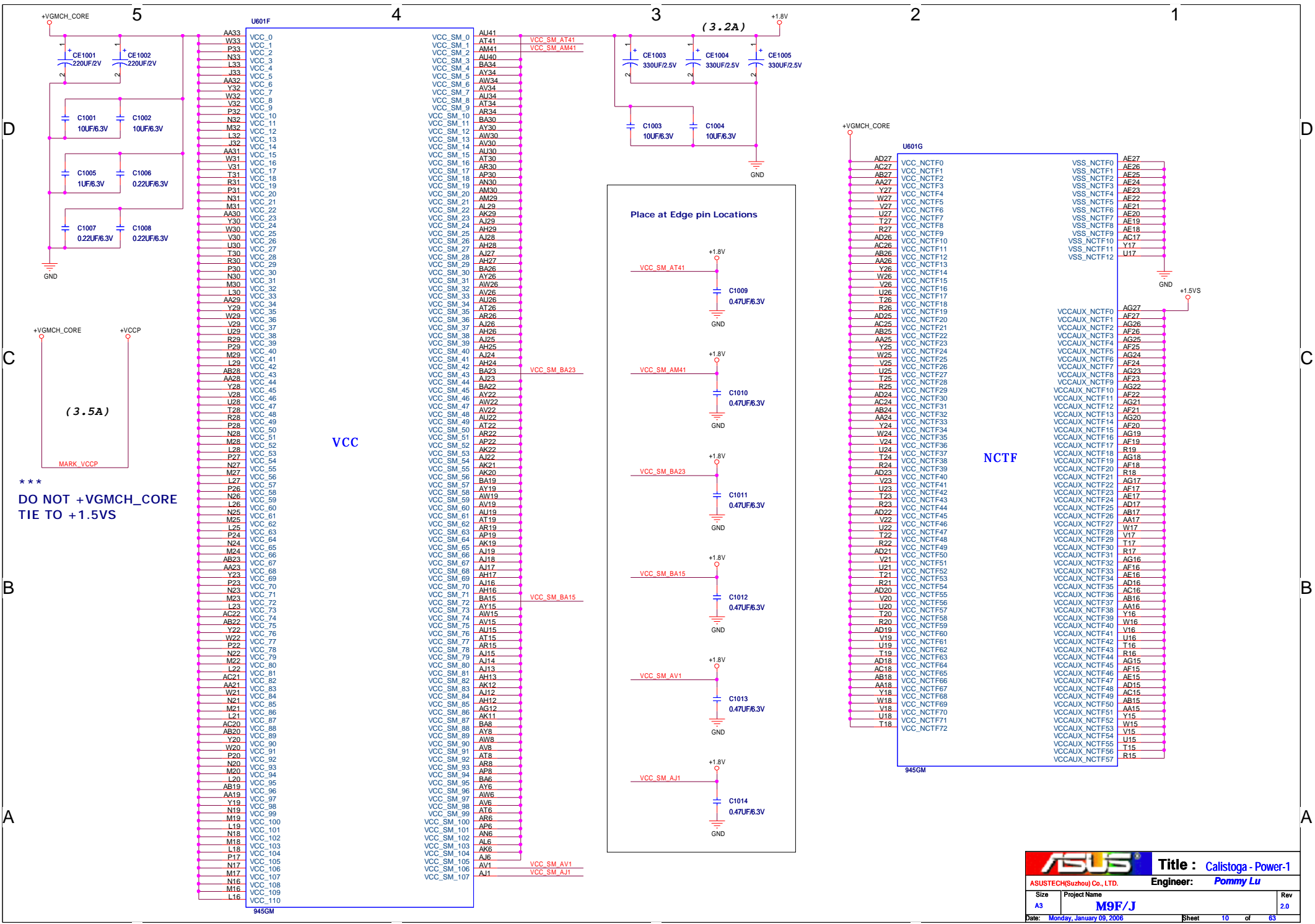

D

D

C

C

B

B

A

A

DO NOT +VGMCH_CORE
TIE TO +1.5VS

Place at Edge pin Locations

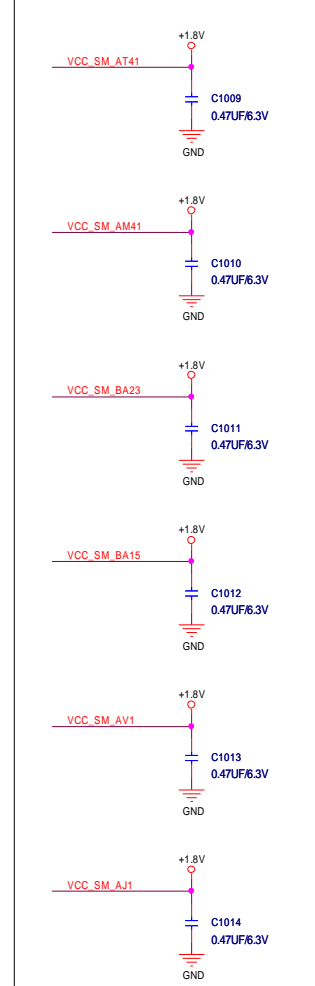

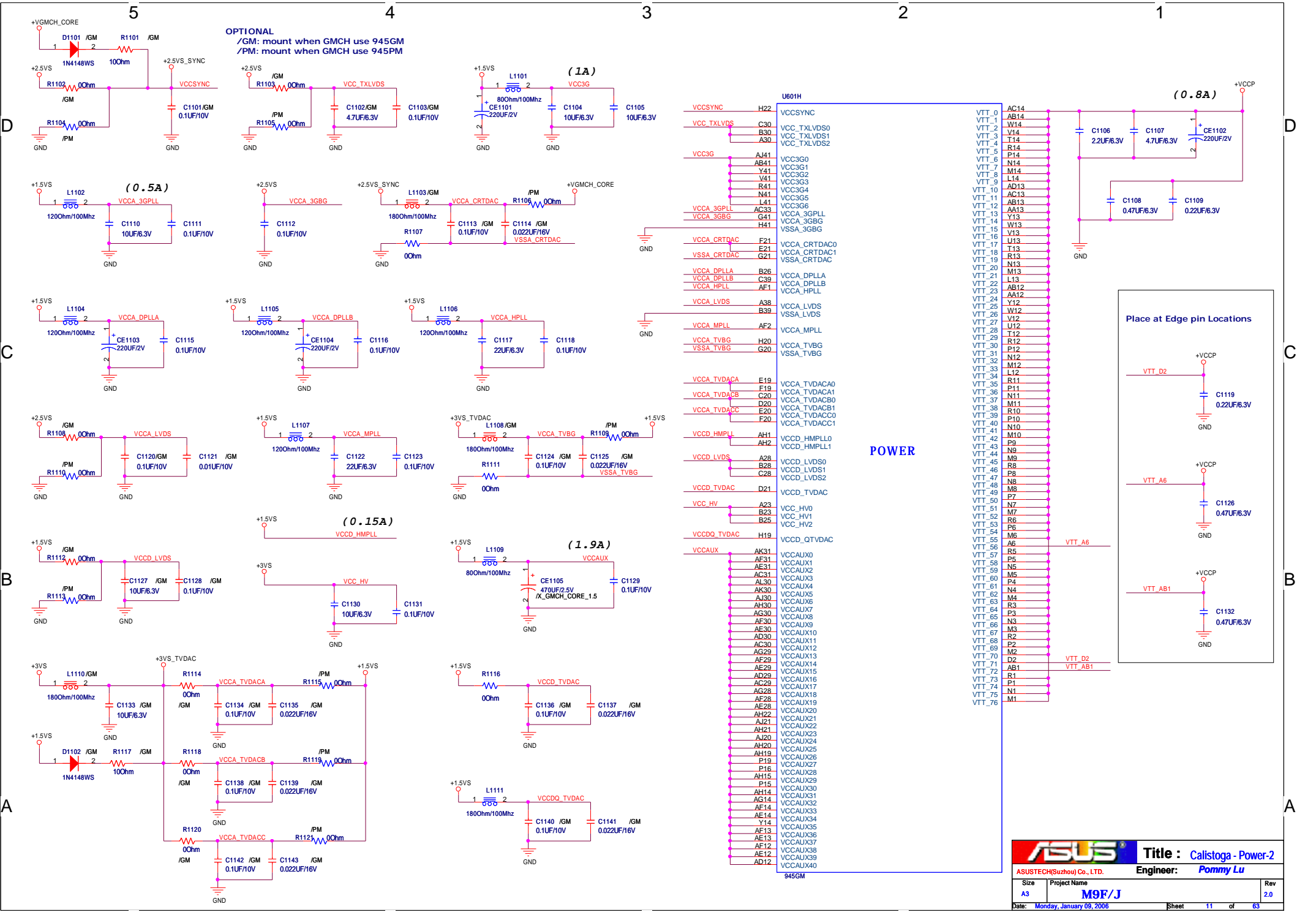

5

4

3

2

1

D

D

C

C

B

B

A

A

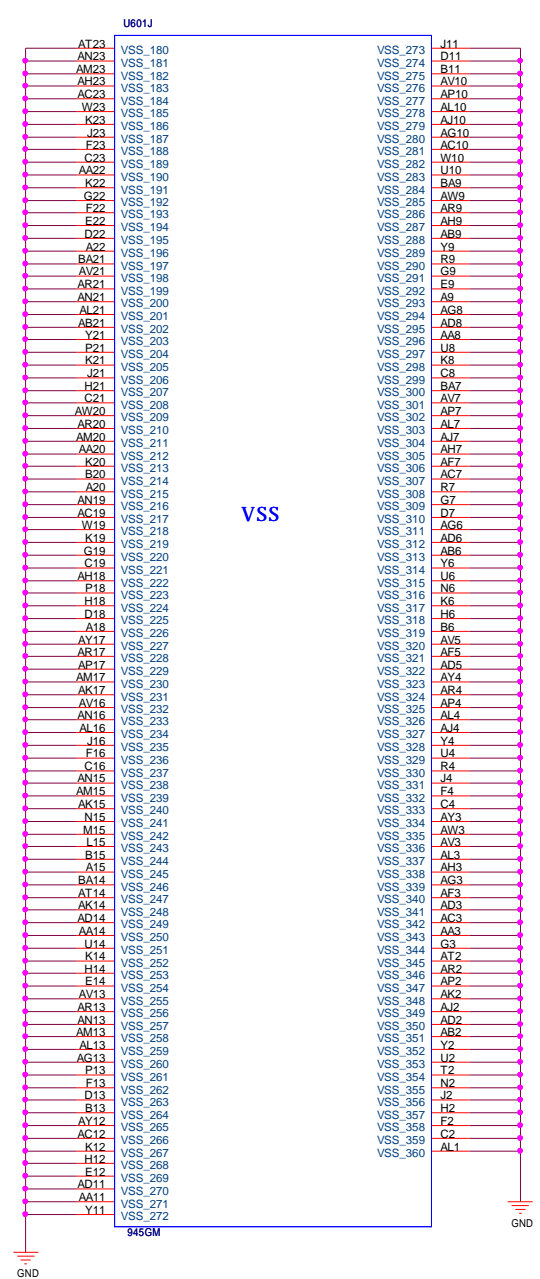
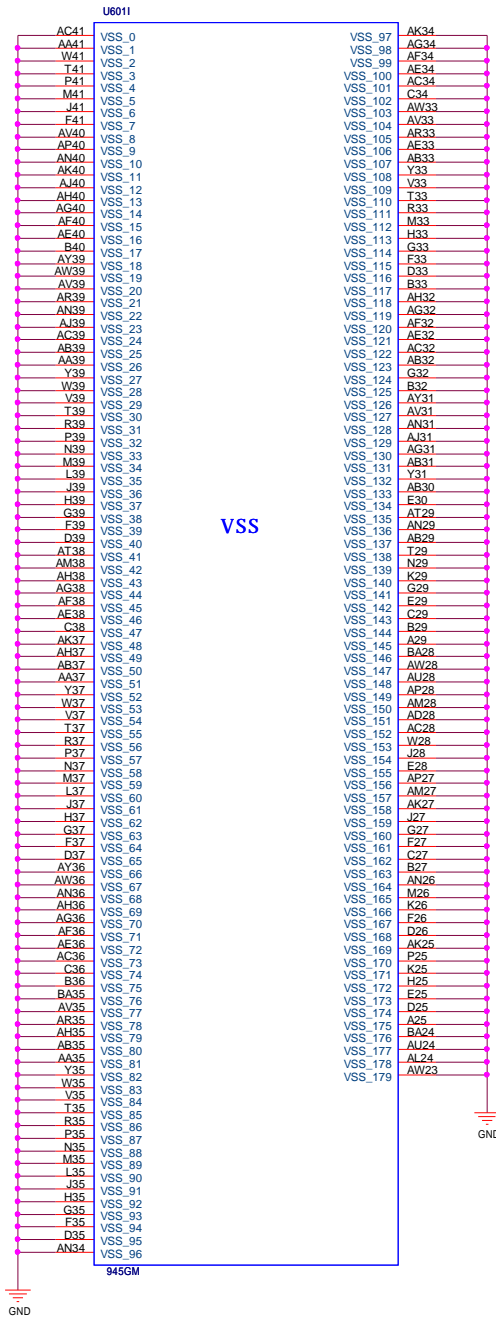

		Title : Calistoga - GND	
ASUSTECH(Suzhou) Co., LTD.		Engineer: Pommy Lu	
Size	Project Name	Rev	
A3	M9F/J	2.0	
Date: Monday, January 09, 2006		Sheet	12 of 63

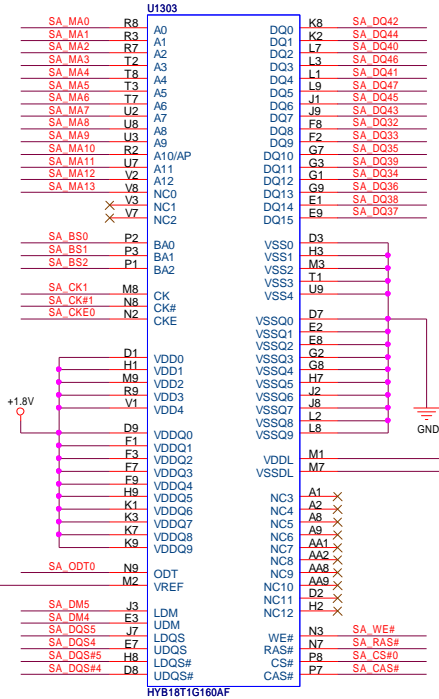
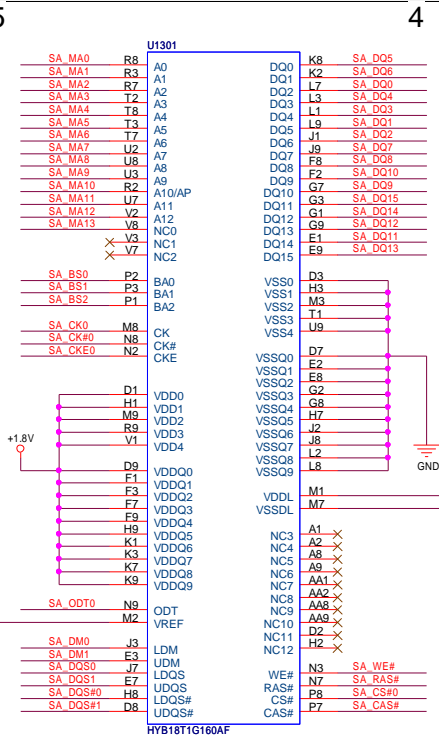

On Board 256MB
DDR2 533 32Mx16-3.7
P/N: 03G15073B010 (1st)
03G15133E110 (2nd)

On Board 512MB
DDR2 533 32Mx16-3.7
P/N: 03G15073B010 (1st)
03G15133E110 (2nd)

On Board 512MB
DDR2 667 32Mx16-3
P/N: (null)

On Board 1GB
DDR2 533 64Mx16-3.7
P/N: 03G15163E010

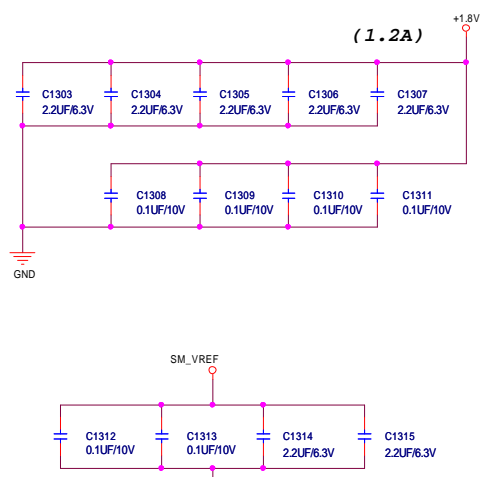
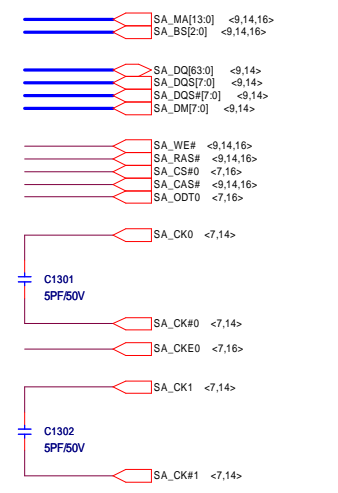
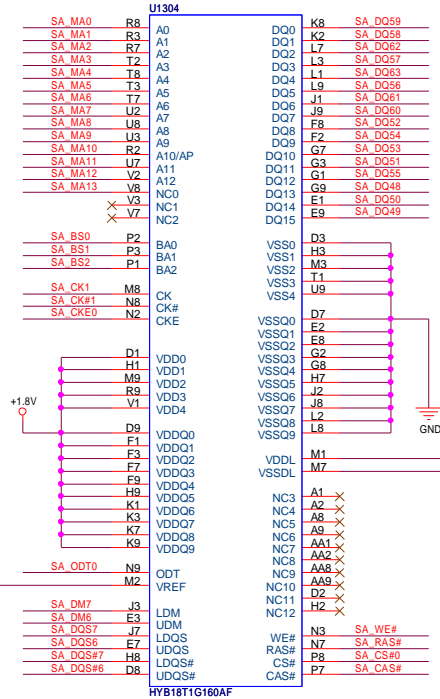
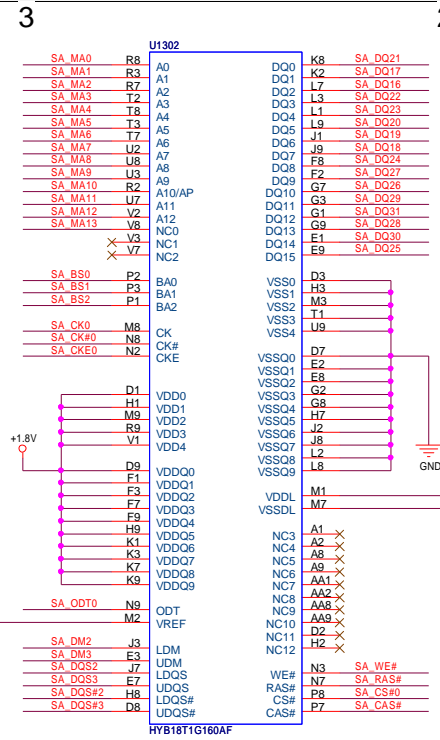

		Title : DDR2 Onboard CHA-1	
ASUSTECH(Suzhou) Co., LTD.		Engineer: Pommy Lu	
Size	Project Name		Rev
A3	M9F/J		2.0
Date: Wednesday, March 01, 2006		Sheet	13 of 63

5 4 3 2 1

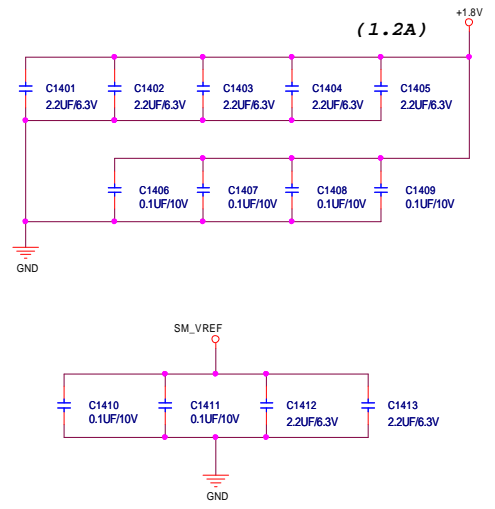
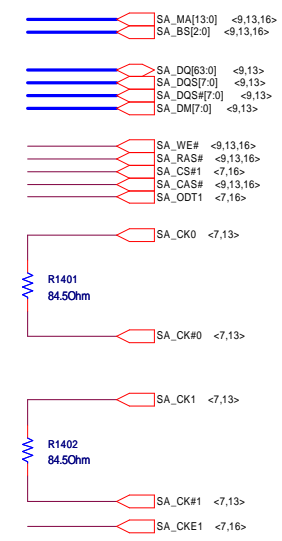
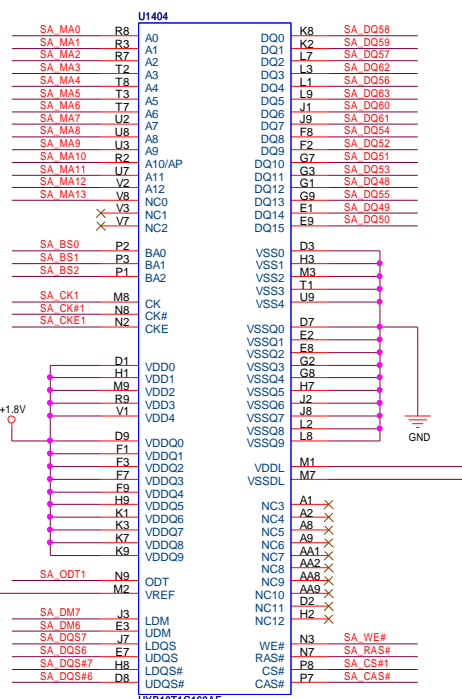
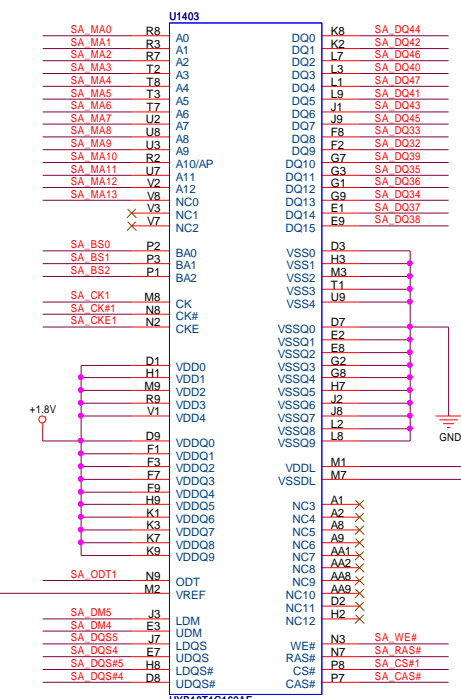
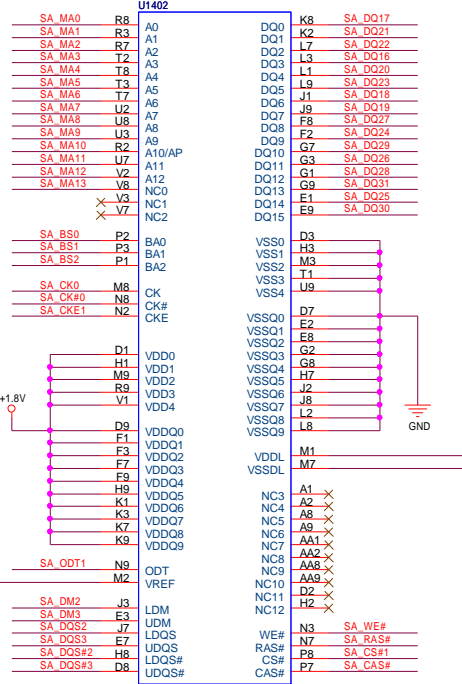
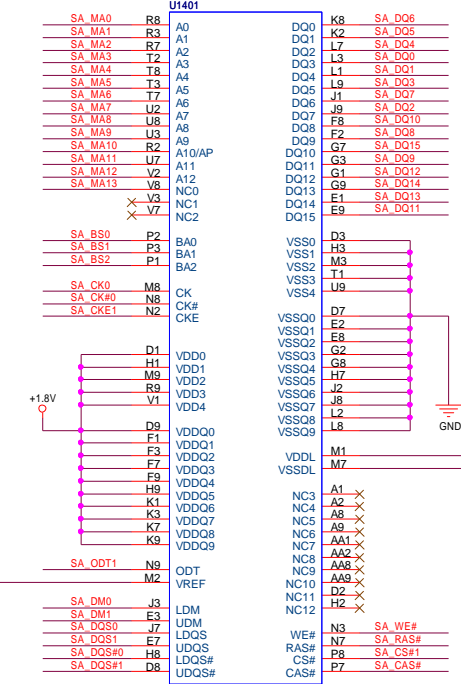

5

4

3

2

1

P/N: 12G025122007

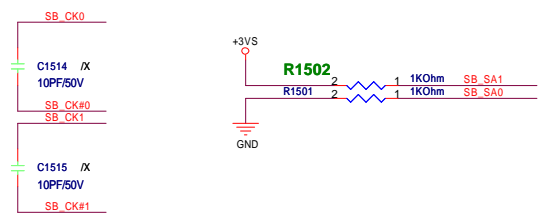
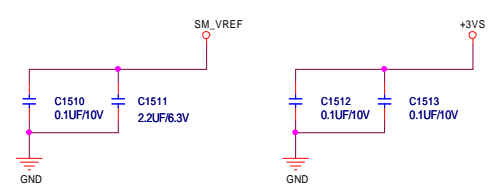
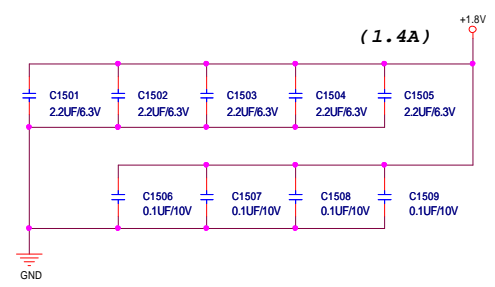
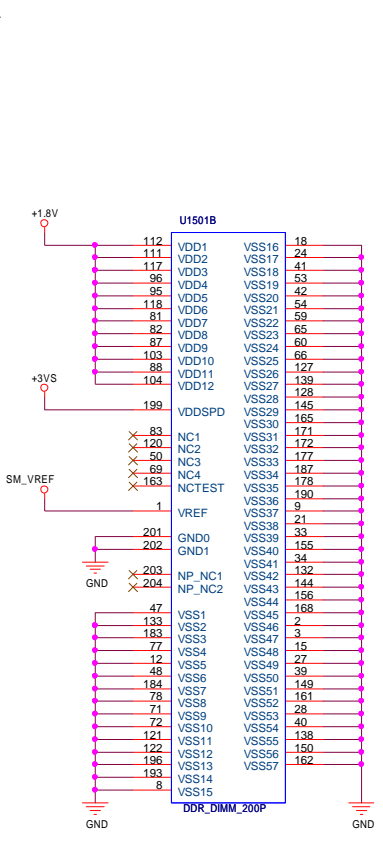
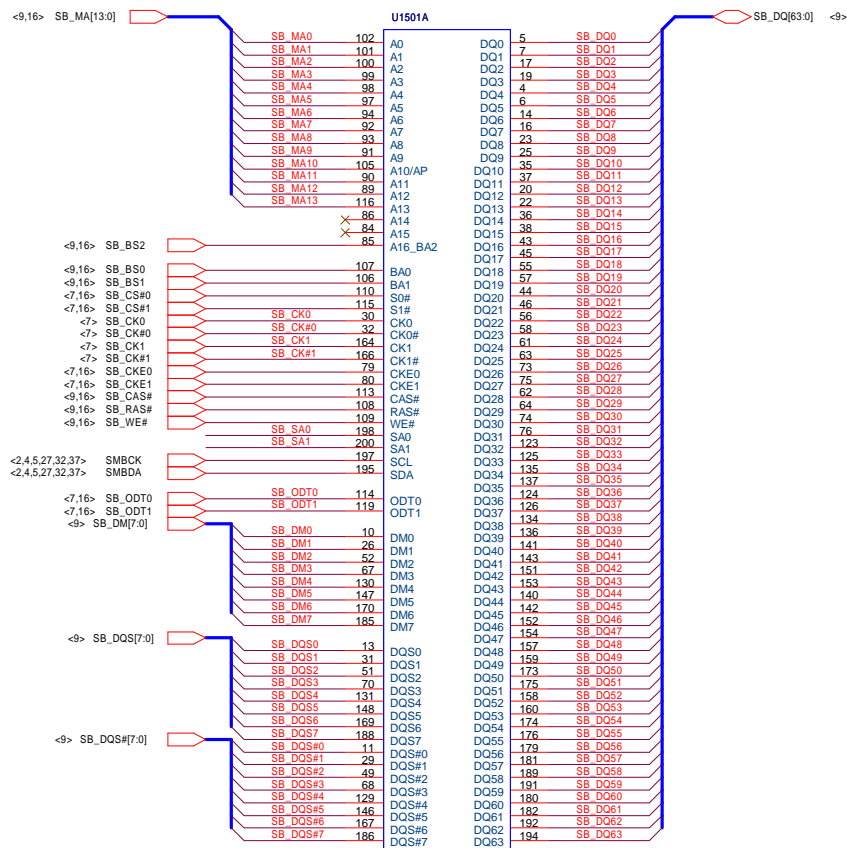

5

4

3

2

1

D

D

C

C

B

B

A

A

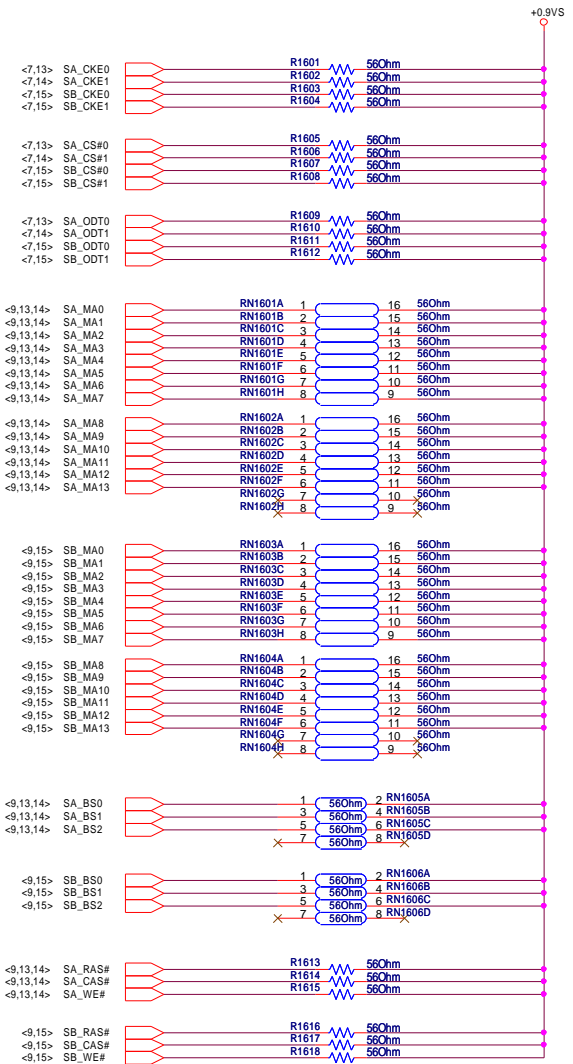

Place one cap close to every 2 pull-up resistors terminated to +0.9VS

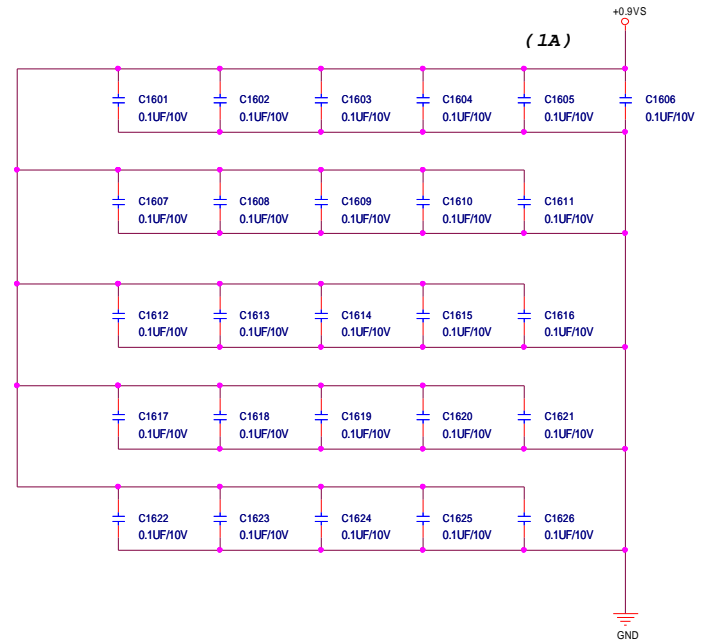

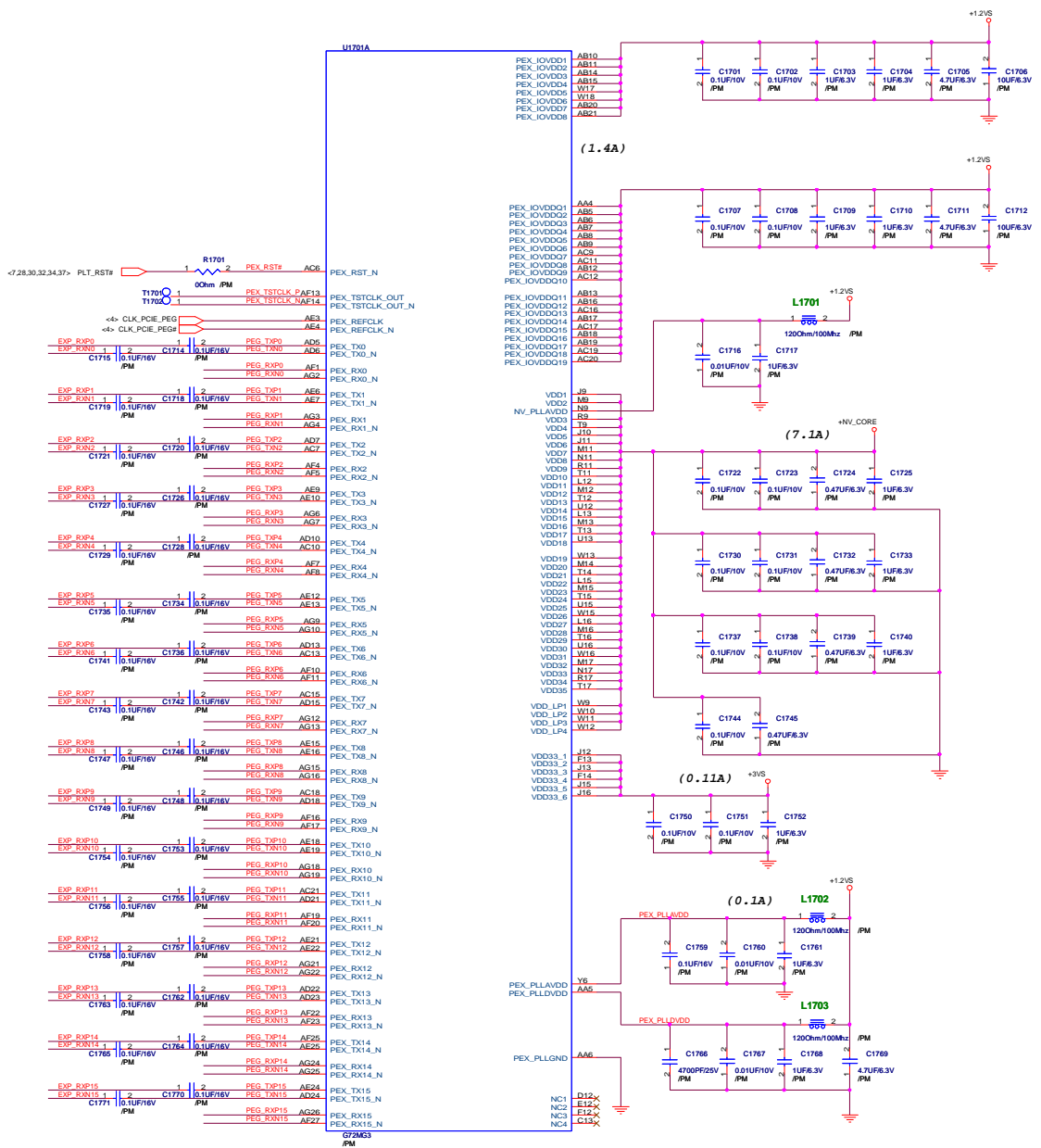

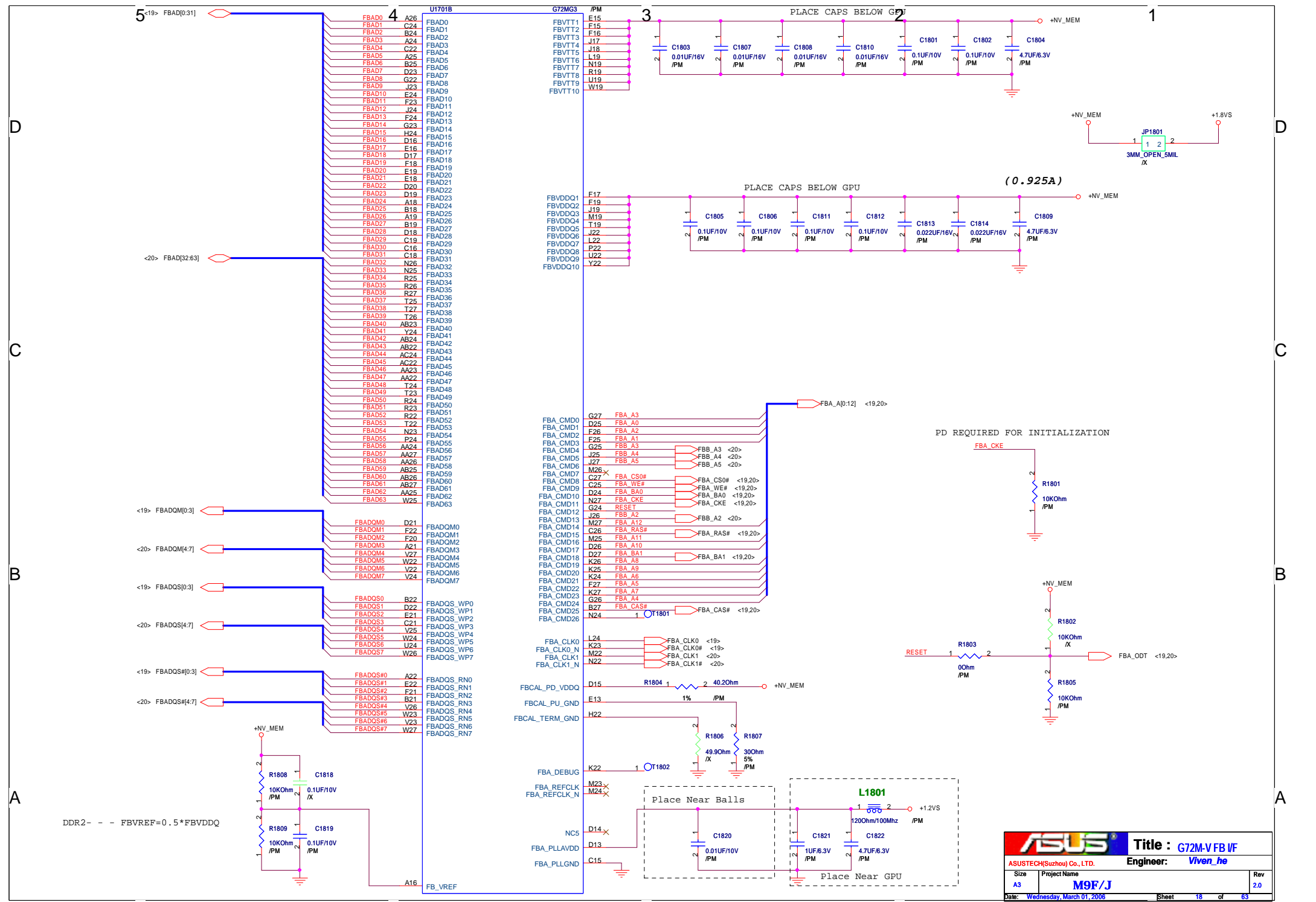

5 4 3 2 1

- <18,20> FBA_A[0:12]
- <18> FBAD[0:31]
- <18> FBADQS[0:3]
- <18> FBADQS# [0:3]
- <18> FBADQM[0:3]

VRAM 16Mx16 - 2.5 (400MHz)
P/N: 03G151236011

VRAM 16Mx16 - 2.5 (400MHz)
P/N: 03G151236011

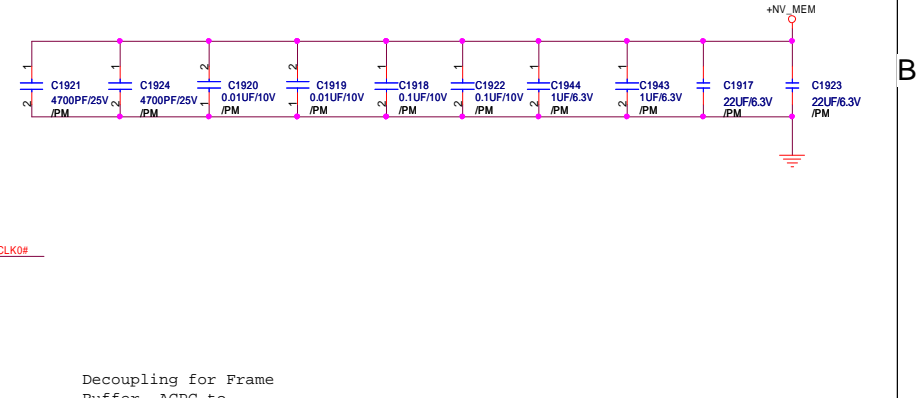
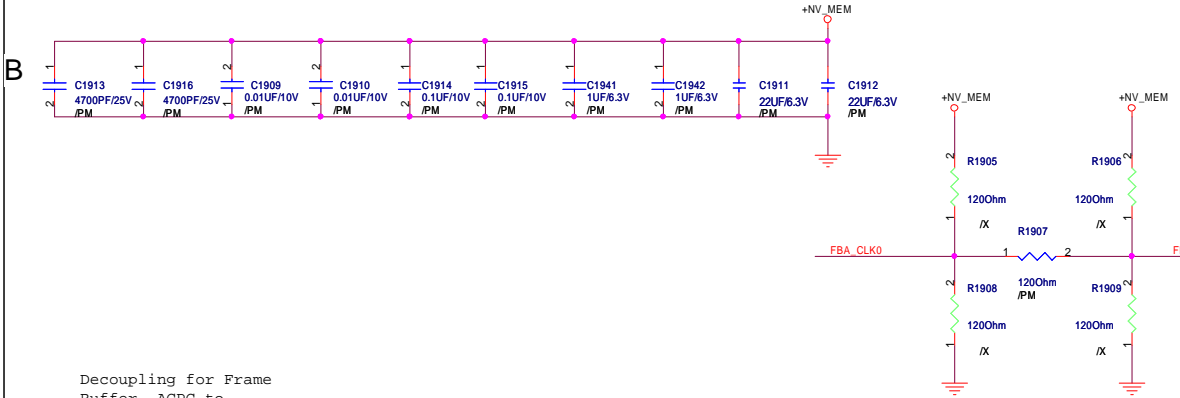
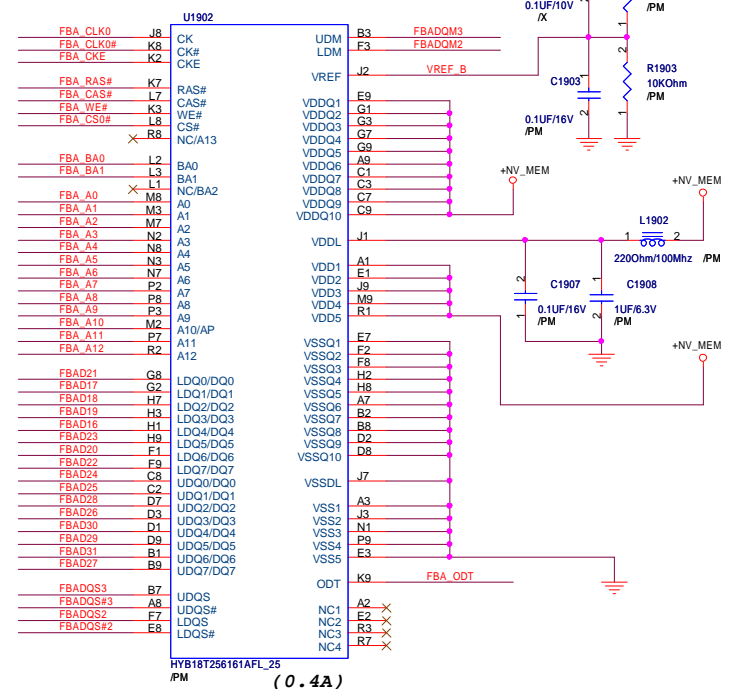
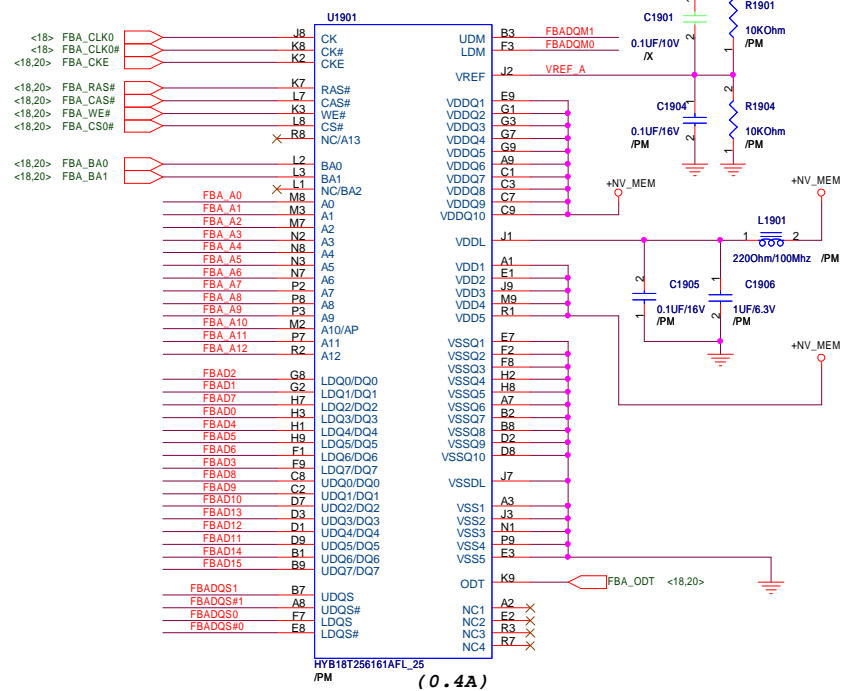

Decoupling for Frame Buffer. ACPC to memory

Decoupling for Frame Buffer. ACPC to memory

- <18,19> FBA_A[0:12]
- <18> FBAD[32:63]
- <18> FBADQS[4:7]
- <18> FBB_A[2:5]
- <18> FBADQS[4:7]
- <18> FBADQM[4:7]

VRAM 16Mx16 - 2.5 (400MHz)
P/N: 03G151236011

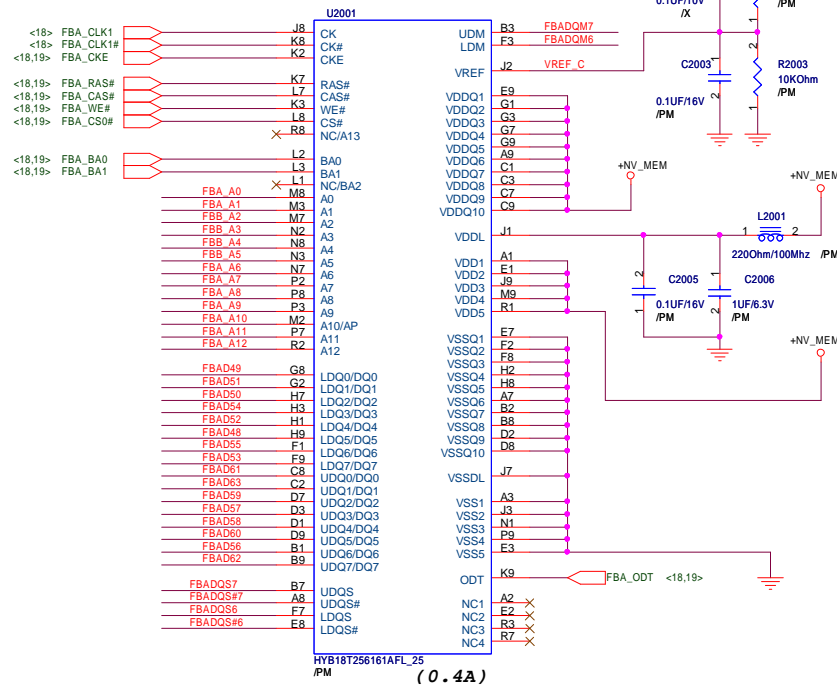

VRAM 16Mx16 - 2.5 (400MHz)
P/N: 03G151236011

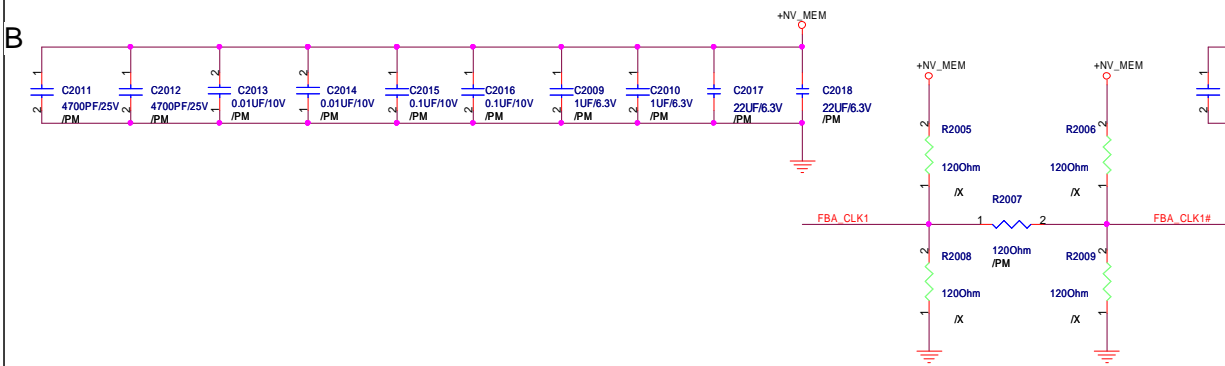
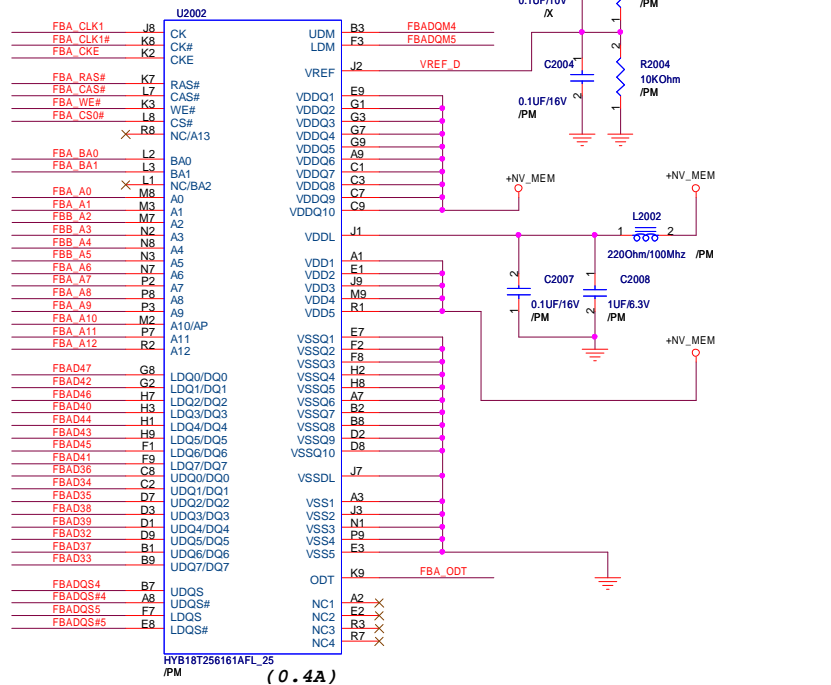

Decoupling for Frame Buffer. ACPC to memory

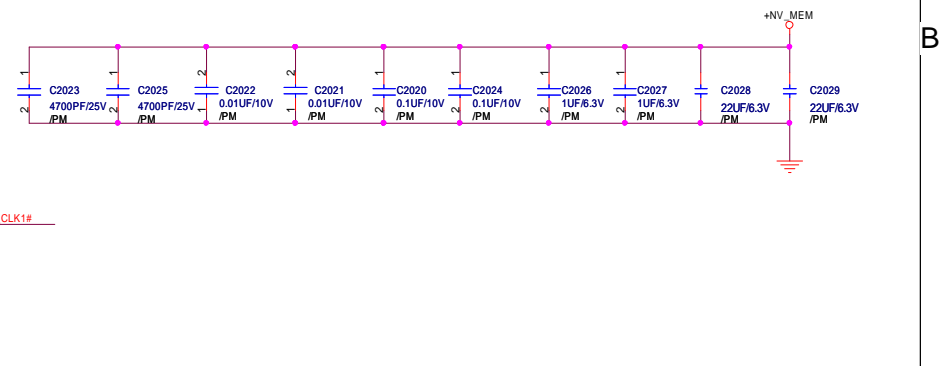

Decoupling for Frame Buffer. ACPC to memory

5 4 3 2 1

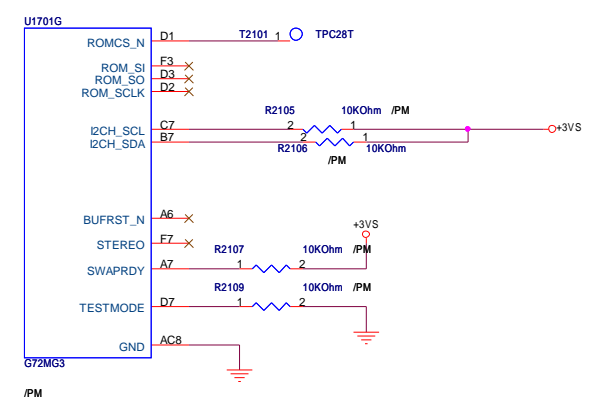
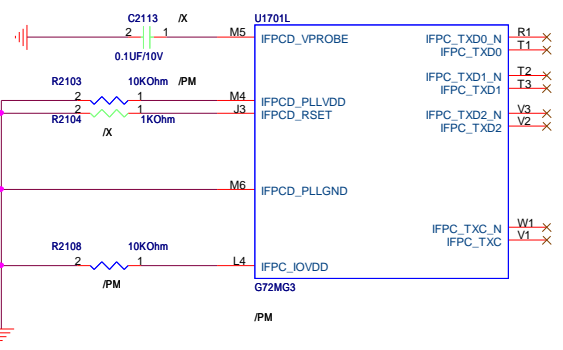
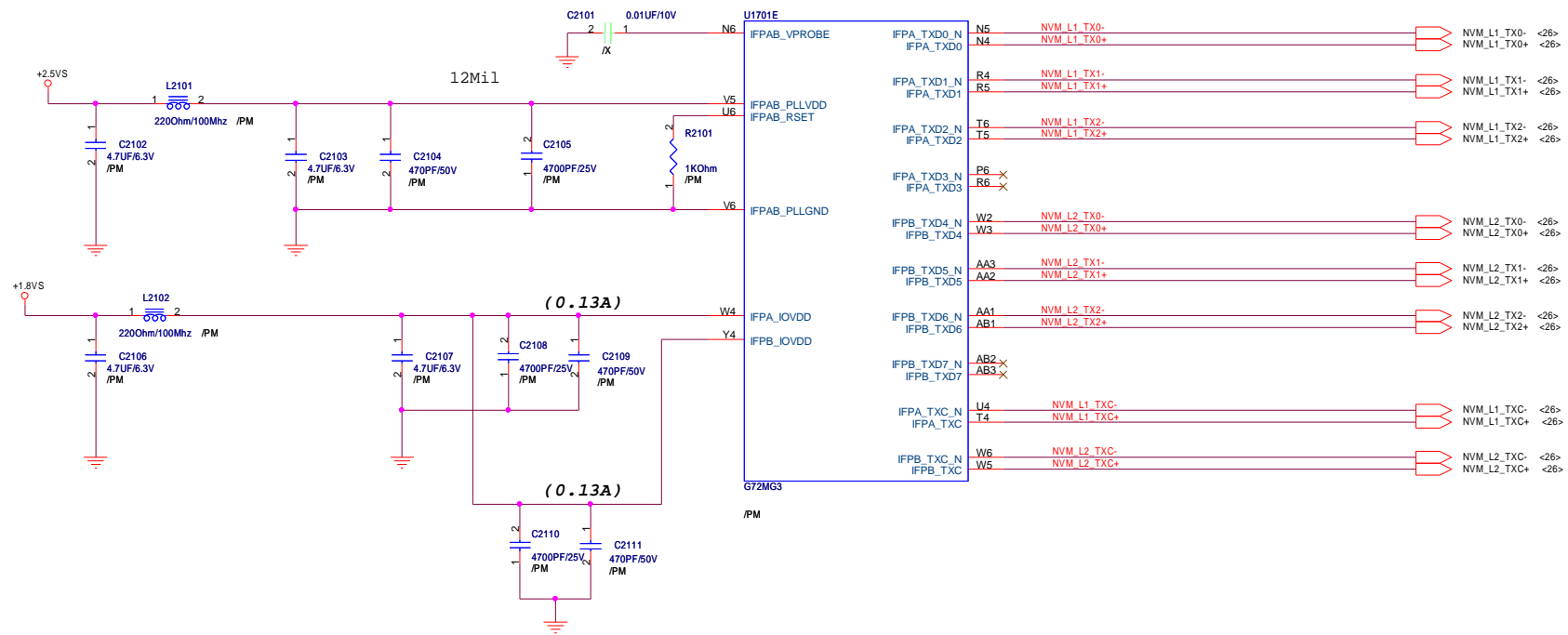

5 4 3 2 1

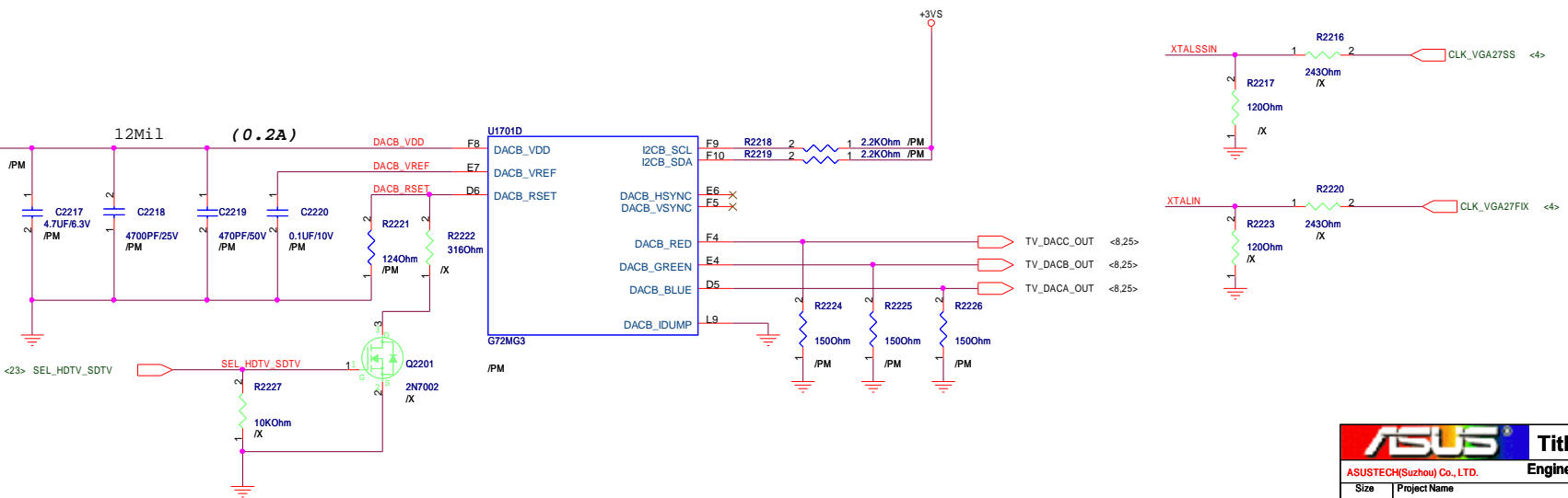
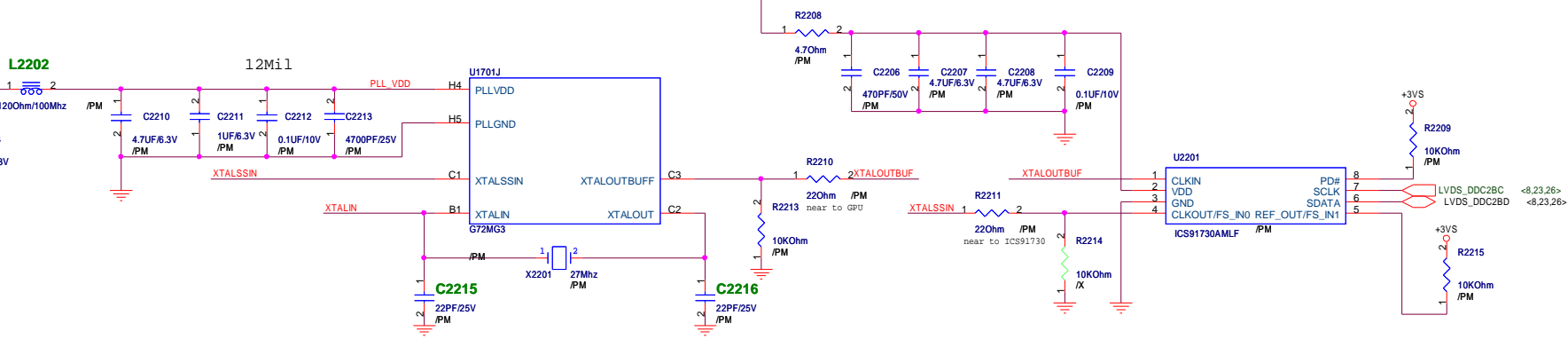
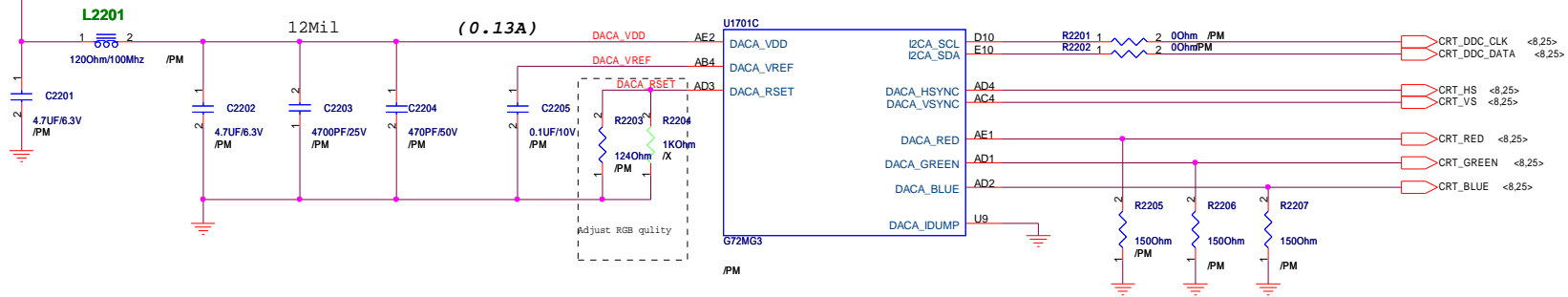

D

D

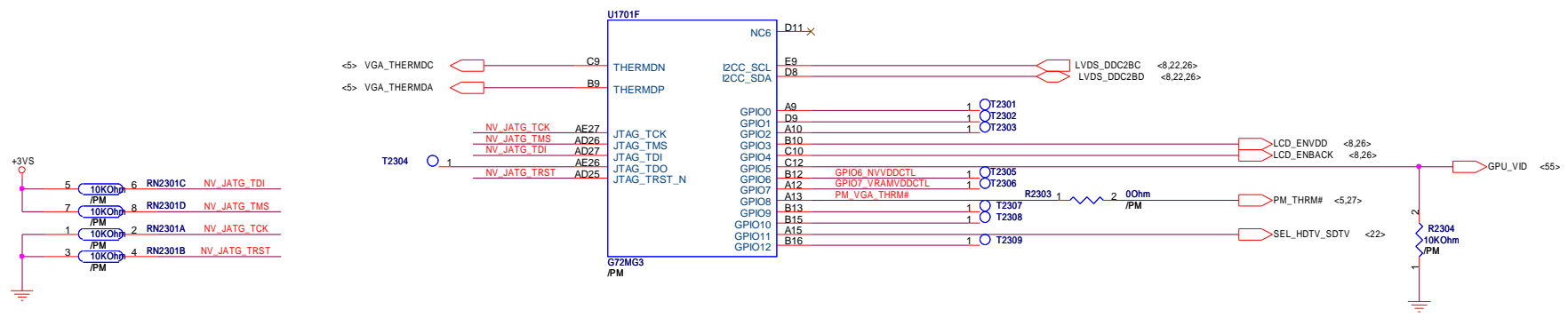

C

C

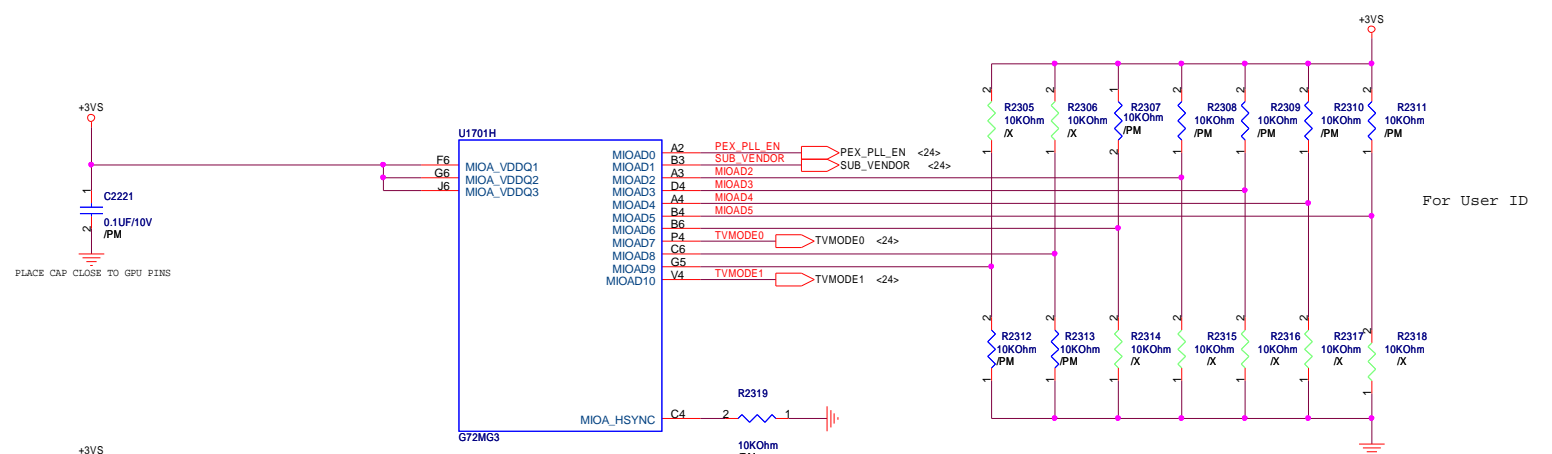

B

B

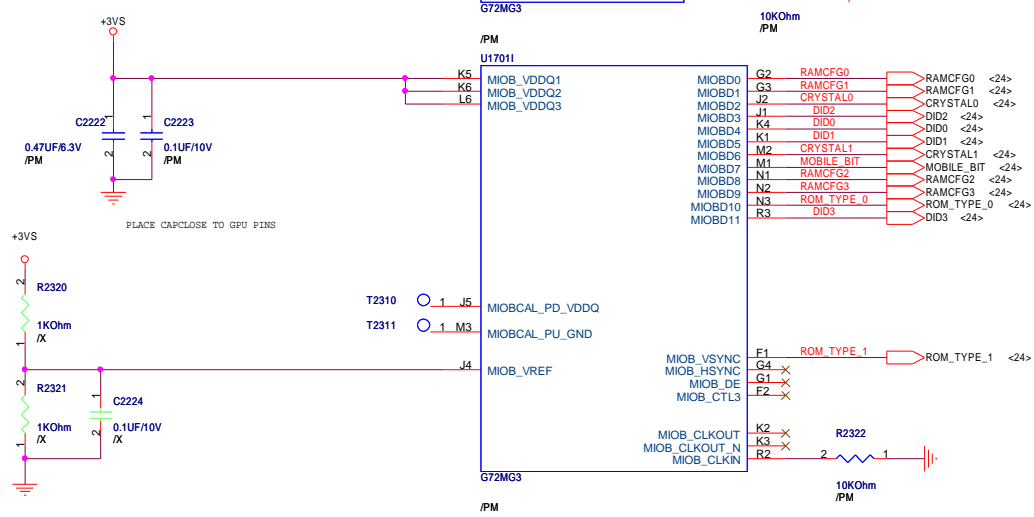

A

A

ASUS		Title : G72M-V GPIO	
ASUSTECH(Suzhou) Co., LTD.		Engineer: <i>Viven_he</i>	
Size	Project Name	Rev	
A3	M9F/J	2.0	
Date: Wednesday, March 01, 2006		Sheet	23 of 63

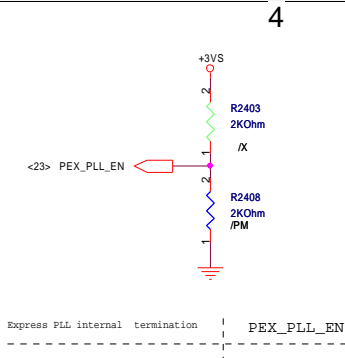
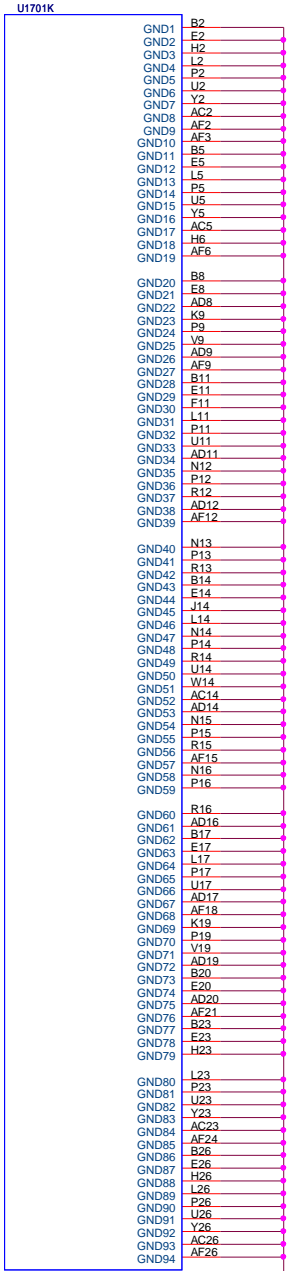

Express PLL internal termination	PEX_PLL_EN
Enable	0
Disable	1

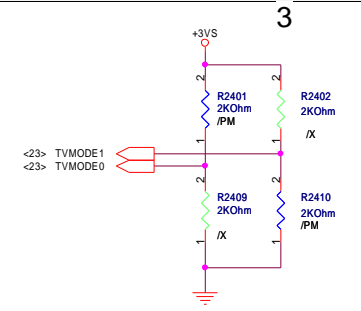

TV Mode	TVMODE1	TVMODE0
SECAN	0	0
PAL	1	0
NTSC(Default)	0	1
CRT	1	1

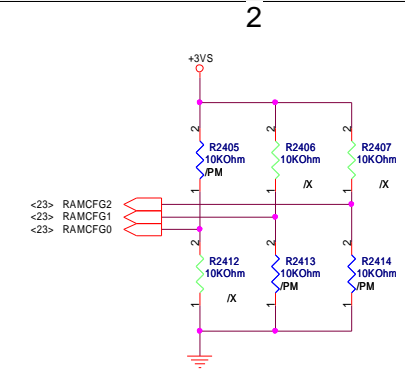

GPU	RAMCFG2	RAMCFG1	RAMCFG0
DDR2 16Gb16x4 128MB,SAMSUNG	0	0	1
DDR2 16Gb16x4 128MB,Infineon	0	1	0
DDR2 16Gb16x4 128MB,Hynix	0	1	1

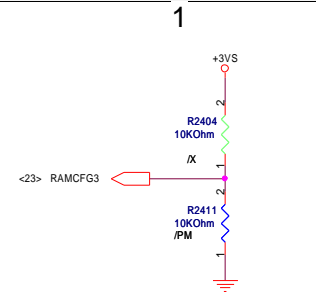

	RAMCFG3
Full width of frame buffer	0
Half width of frame buffer	1

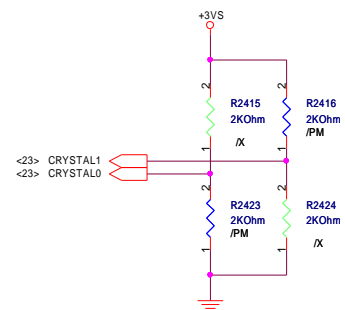

CRYSTAL	CRYSTAL1	CRYSTAL0
13.5MHZ	0	0
27MHZ(Default)	1	0
14.318MHZ	0	1
Reserved	1	1

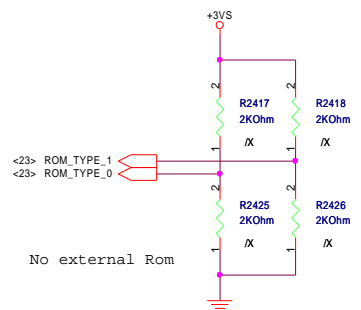

ROM_TYPE	ROM_TYPE_1	ROM_TYPE_0
Parallel	0	0
Reserved	1	0
Serial AT25F(Default)	0	1
LPC	1	1

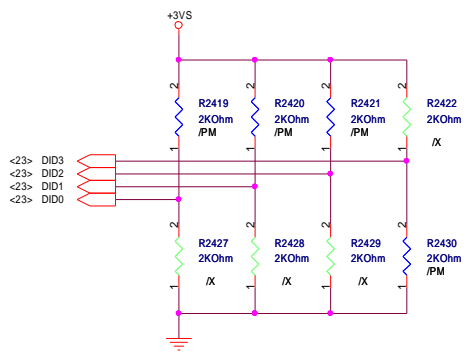

GPU	DID3	DID2	DID1	DID0
G72M	1	0	0	0
G72M-V	0	1	1	1

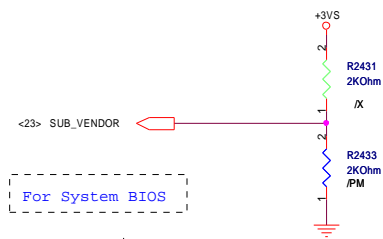

	SUB_VENDOR
System BIOS	0
Adapter BIOS	1

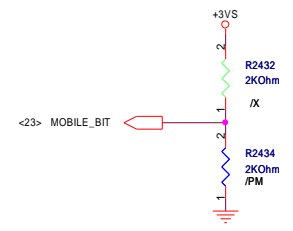

MOBILE_BIT= 0: MOBILE

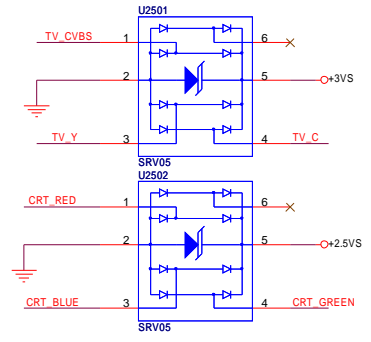
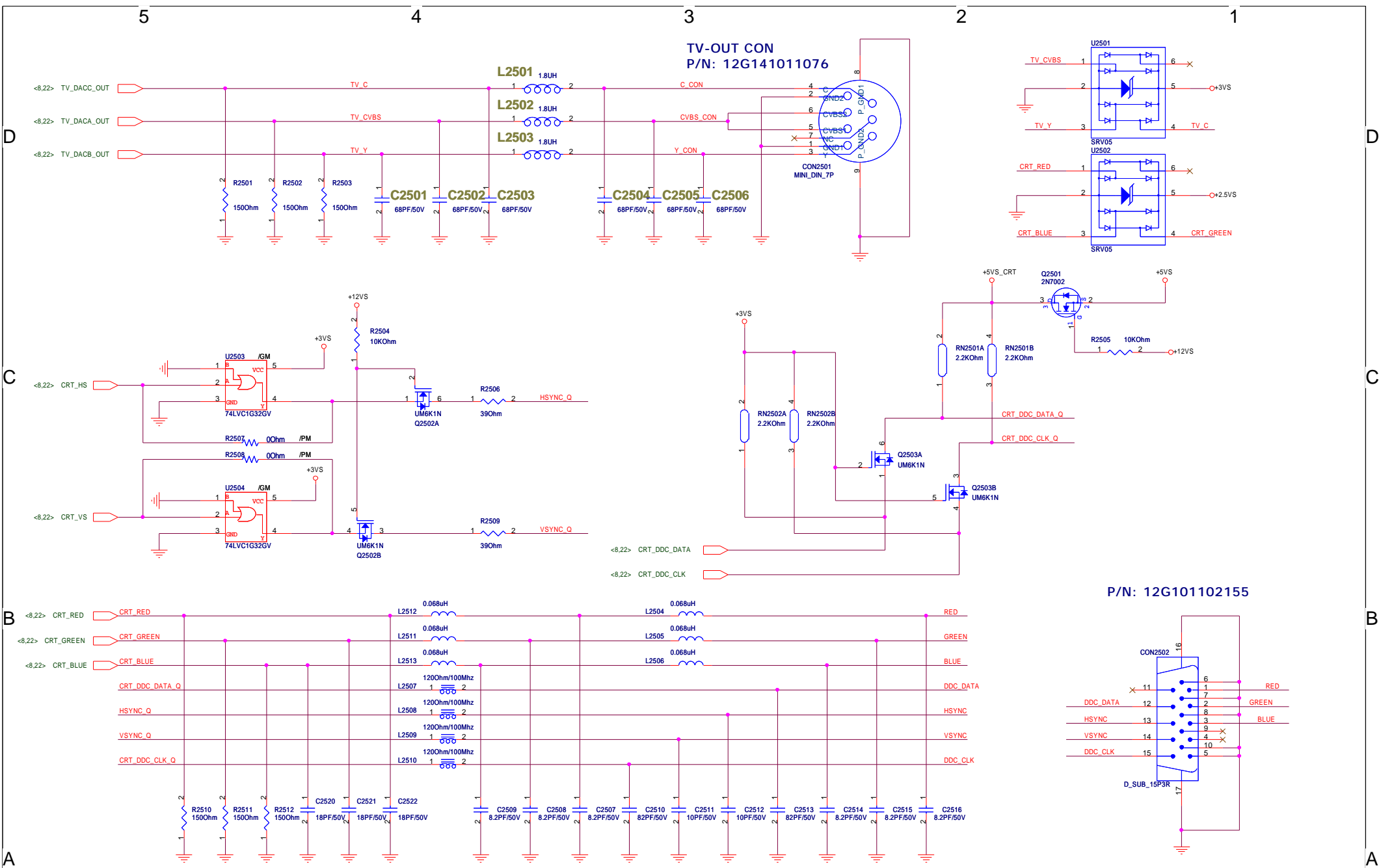

P/N: 12G101102155

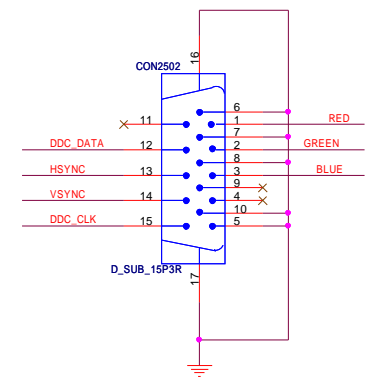

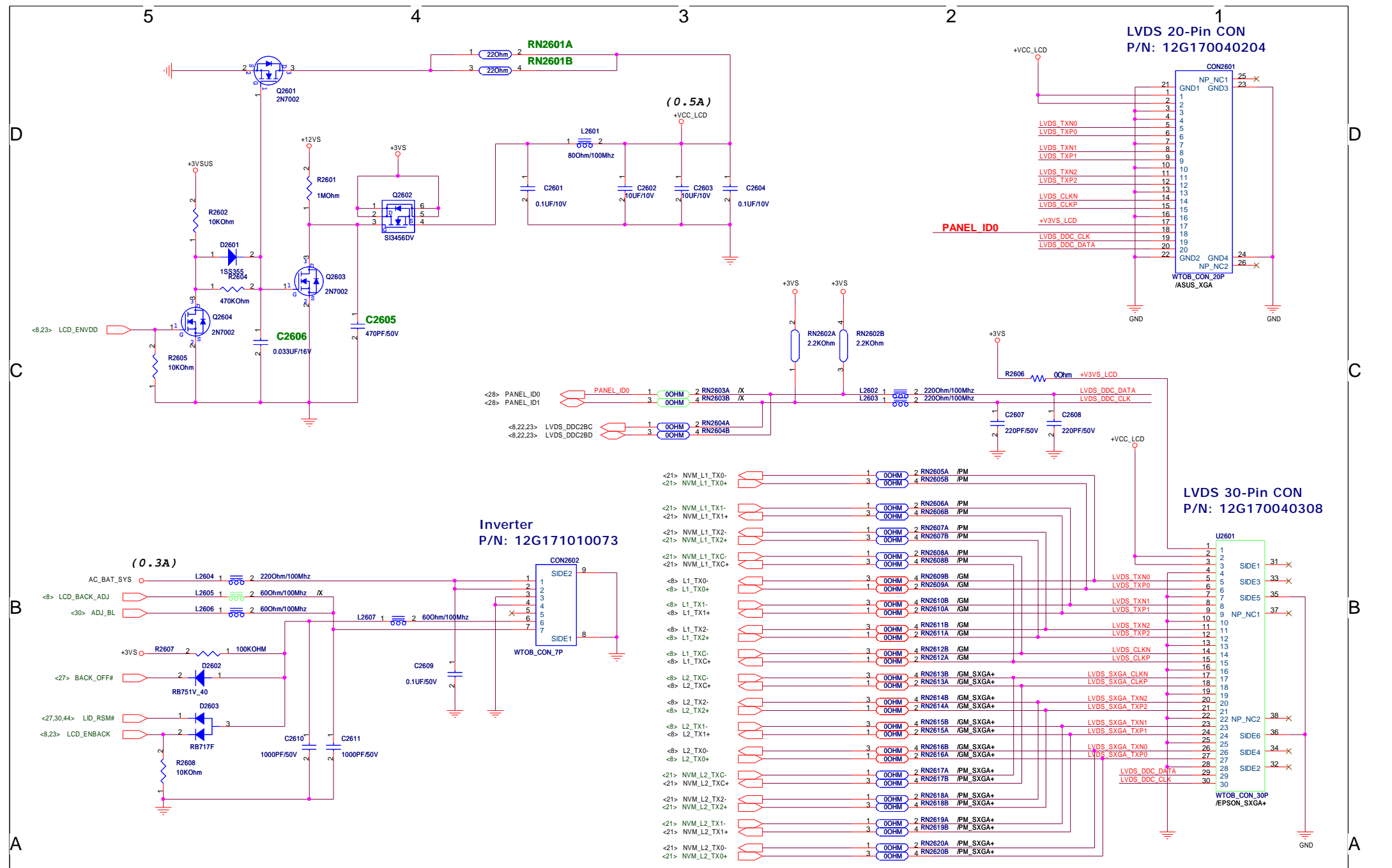

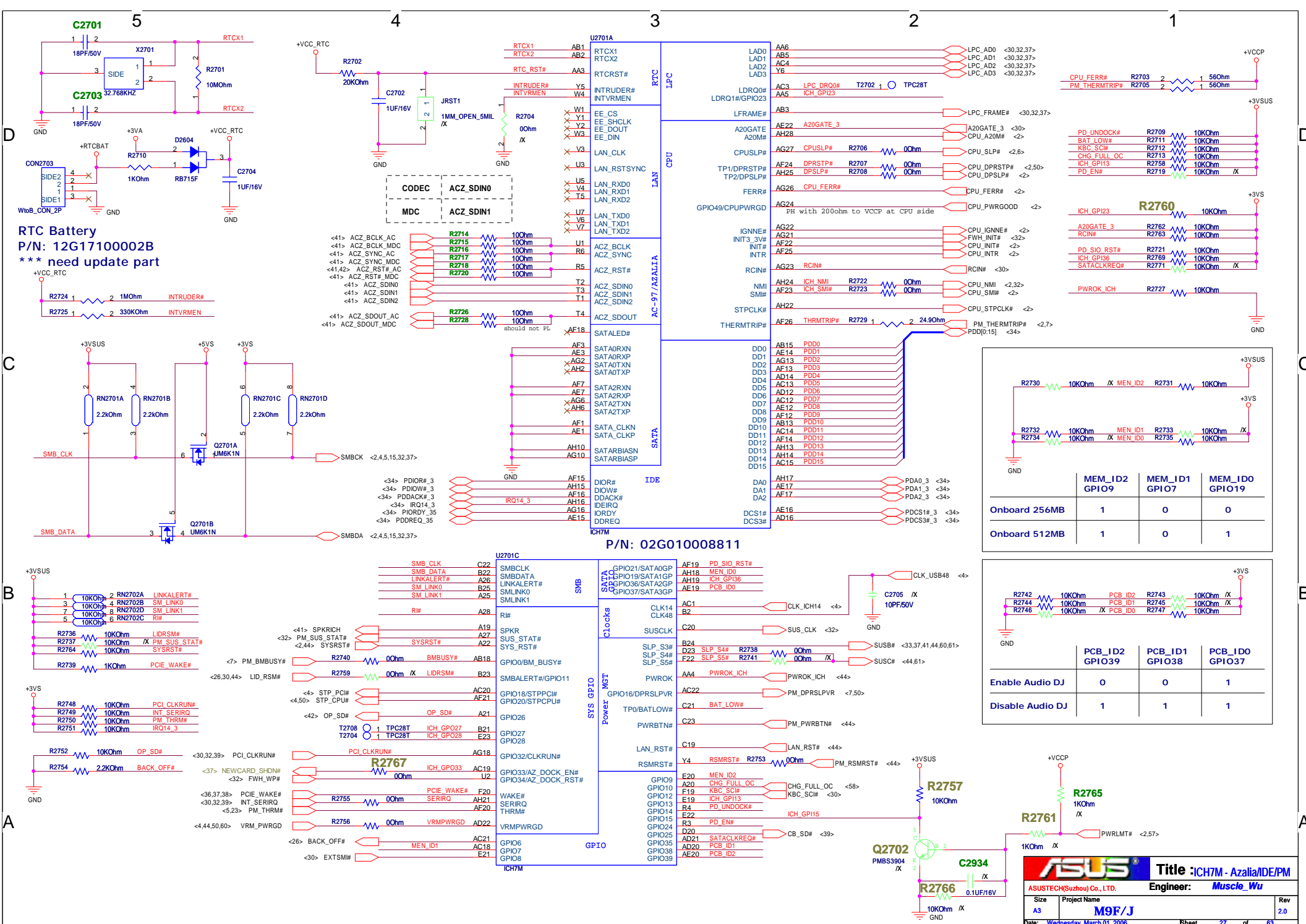

D

RTC Battery
 P/N: 12G17100002B
 *** need update part

C

SMB_CLK
 SMB_DATA

B

LINKALERT#
 SM_LINK0
 SM_LINK1
 RI#

A

PCI_CLKRUN#
 BACK_OFF#

CODEC ACZ_SDIN0

<41> ACZ_BCLK_AC
 <41> ACZ_BCLK_MDC
 <41> ACZ_SYNC_AC
 <41> ACZ_SYNC_MDC
 <41,42> ACZ_RST#_AC
 <41> ACZ_RST#_MDC
 <41> ACZ_SDIN0
 <41> ACZ_SDIN1
 <41> ACZ_SDIN2
 <41> ACZ_SDOUT_AC
 <41> ACZ_SDOUT_MDC

U2701C

SMB_CLK C22
 SMB_DATA B22
 LINKALERT# A26
 SM_LINK0 B25
 SM_LINK1 A25
 RI# A28

<41> SPKRICH A19
 <32> PM_SUS_STAT# A27
 <2,44> SYSRST# A22

<7> PM_BMBUSY# R2740
 <26,30,44> LID_RSM# R2759

<4> STP_PCIF# AC20
 <4,50> STP_CPU# AE21

<42> OP_SD# A21

T2708 T2704
 1 TPC28T ICH_GPO27 B21
 2 TPC28T ICH_GPO28 E23

GPIO32/CLKRUN# AG18
 GPIO33/AZ_DOCK_EN# AC19
 GPIO34/AZ_DOCK_RST# U2

WAKE# F20
 SERIRQ AH21
 THRM# AF20

VRMPWRGD AD22

BACK_OFF# AC21
 GPIO6 AC18
 GPIO7 E21
 GPIO8 E23
 ICH7M

U2701A

RTCX1 AB1
 RTCX2 AB2
 RTC_RST# AA3
 INTRUDER# Y5
 INTVRMEN W4

EE_CS X1
 EE_SHCLK X2
 EE_DOUT X3
 EE_DIN X4

LAN_CLK U3
 LAN_RSTSYNC U4
 LAN_RXD0 U5
 LAN_RXD1 U4
 LAN_RXD2 U5

LAN_TXD0 U7
 LAN_TXD1 U6
 LAN_TXD2 U7

U1 ACZ_BCLK
 R6 ACZ_SYNC
 R5 ACZ_RST#
 T2 ACZ_SDIN0
 T3 ACZ_SDIN1
 T1 ACZ_SDIN2
 T4 ACZ_SDOUT
 AF18 ACZ_SDOUT_MDC

SATALED# AF18

AF3 SATA0RXN
 AE3 SATA0RXP
 AG2 SAT_A0TXN
 AH2 SAT_A0TXP
 AF7 SATA2RXN
 AE7 SATA2RXP
 AG6 SAT_A2TXN
 AH6 SAT_A2TXP
 AE1 SATA_CLKN
 AF1 SATA_CLKP
 AH10 SATARBIASN
 AG10 SATARBIASP

DIOR# AF15
 DIOW# AH15
 DDACK# AF16
 IDEIRO AH16
 JORDY AG16
 DDREQ AE15

GPIO21/SATA0GP AF19
 GPIO19/SATA1GP AH18
 GPIO36/SATA2GP AH19
 GPIO37/SATA3GP AE19

CLK_USB48 <4>
 CLK_USB48 10PF/50V

CLK14 CLK48
 AC1 B2
 B2

SUSCLK C20
 SUS_CLK <32>
 SUSB# <33,37,41,44,60,61>
 SUSC# <44,61,4>

PWROK AA4
 PWROK_ICH PWROK_ICH <44>

AC22
 C21 BAT_LOW#
 C22

C23
 C23

C19
 LAN_RST# <44>

Y4
 RSMRST# R2753
 PM_RSMRST# <44>

GPIO9 E20
 GPIO10 A20
 GPIO12 F19
 GPIO13 E19
 GPIO14 R4
 GPIO15 E22
 GPIO24 R3
 GPIO25 D20
 GPIO35 AD21
 GPIO38 AD20
 GPIO39 AE20

PD_SIO_RST# AF19
 MEN_ID0 AH18
 ICH_GPIB6 AH19
 PCB_ID0 AE19

CLK_ICH14 <4>
 CLK_ICH14 10PF/50V

SUS_CLK <32>
 SUSB# <33,37,41,44,60,61>
 SUSC# <44,61,4>

PWROK_ICH <44>
 PM_DPRSLPVR <7,50>
 C21 BAT_LOW#

PM_PWRBTN# <44>
 PM_PWRBTN#

LAN_RST# <44>
 LAN_RST#

RSMRST# R2753
 PM_RSMRST# <44>

MEN_ID2 E20
 CHG_FULL_OC A20
 KBC_SCI# F19
 ICH_GPH13 E19
 PD_UNDOCK# R4
 ICH_GPH15 R3
 PD_EN# R3
 CB_SD# <39>
 SATACLKREQ# AD21
 PCB_ID1 AD20
 PCB_ID2 AE20

U2701A

LAD0 AA6
 LAD1 AB5
 LAD2 AC4
 LAD3 Y6

LPC_DRQ0# AC3
 ICH_GPI23 AA5

LPC_FRAME# AB3
 A20GATE_3 AE22
 CPU_SLIP# AG27
 DPRSTP# AF24
 DPSLP# AH25
 CPU_FERR# AG26
 PH with 200ohm to VCCP at CPU side AG24
 CPU_PWRGOOD <2>
 AG24
 CPU_IGNNE# AG22
 FWL_INIT# AG21
 CPU_INTR# AF22
 RCIN# AG23
 CPU_NMI <2,32>
 CPU_SMI# AF23
 CPU_STPCLK# <2>
 CPU_STPCLK# AH22
 PM_THERMTRIP# <2,7>
 PM_THERMTRIP# AF26

LPC_AD0 <30,32,37>
 LPC_AD1 <30,32,37>
 LPC_AD2 <30,32,37>
 LPC_AD3 <30,32,37>

LPC_FRAME# <30,32,37>
 A20GATE_3 <30>
 CPU_SLIP# <2,6>
 CPU_DPRSTP# <2,50>
 CPU_DPSLP# <2>
 CPU_FERR# <2>
 CPU_PWRGOOD <2>
 CPU_IGNNE# <2>
 FWL_INIT# <32>
 CPU_INTR# <2>
 RCIN# <30>
 CPU_NMI <2,32>
 CPU_SMI# <2>
 CPU_STPCLK# <2>
 CPU_STPCLK# <2>
 PM_THERMTRIP# <2,7>
 PM_THERMTRIP# <2,7>

U2701A

DD0 AB15
 DD1 AE14
 DD2 AG13
 DD3 DD2
 DD4 AD14
 DD5 AC13
 DD6 AD12
 DD7 AC12
 DD8 AE12
 DD9 AF12
 DD10 AB13
 DD11 AC14
 DD12 AF14
 DD13 AH13
 DD14 AH14
 DD15 AC15

PDA0_3 <34>
 PDA1_3 <34>
 PDA2_3 <34>

PDCS#_3 <34>
 PDCS#_3 <34>

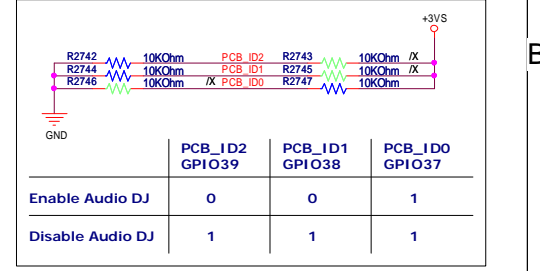
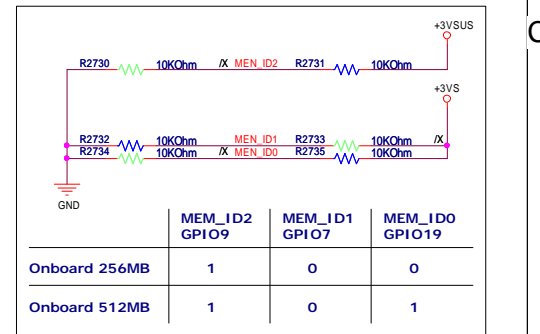

D

C

B

A

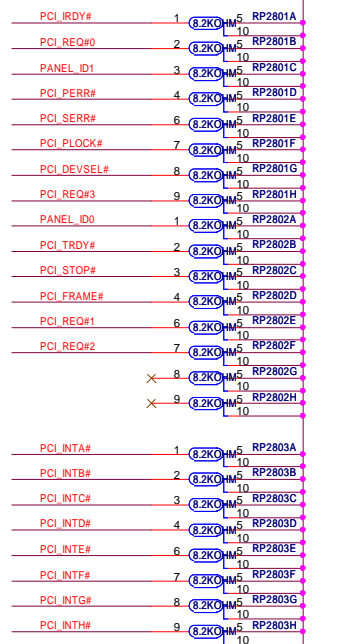
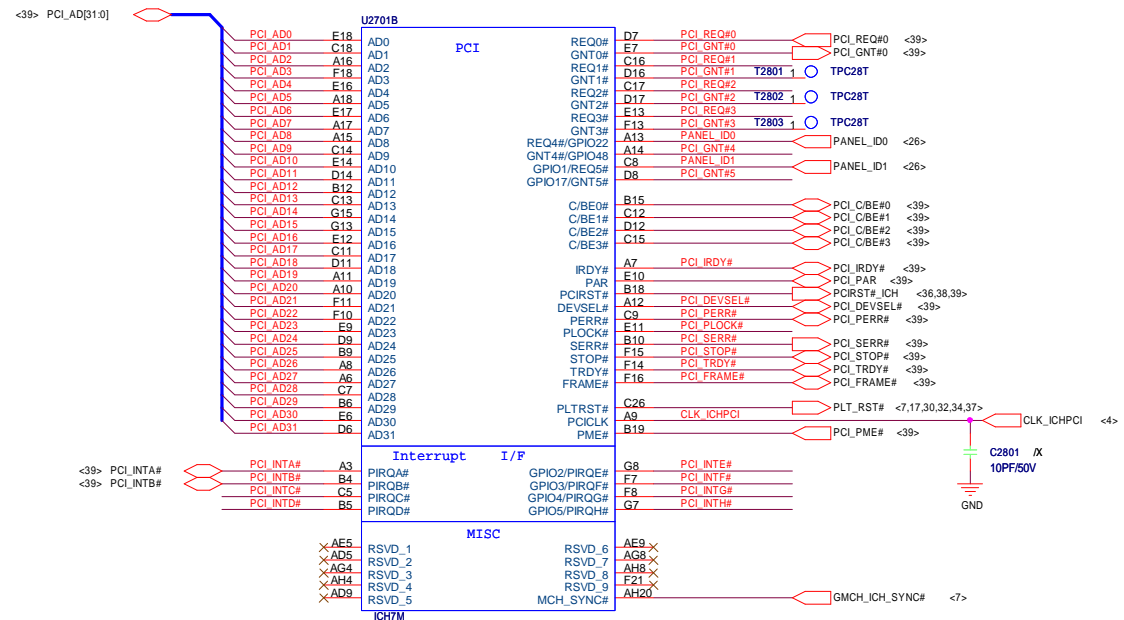

P/N: 02G010008811

Strap:
Boot BIOS Destination

GNT#5	GNT#4	(internal pull-ups)
0	1	SPI
1	0	PCI
1	1	LPC (default)

PCI_GNT#5 R2801 2 1 10KOhm /X
 PCI_GNT#4 R2802 2 1 10KOhm /X

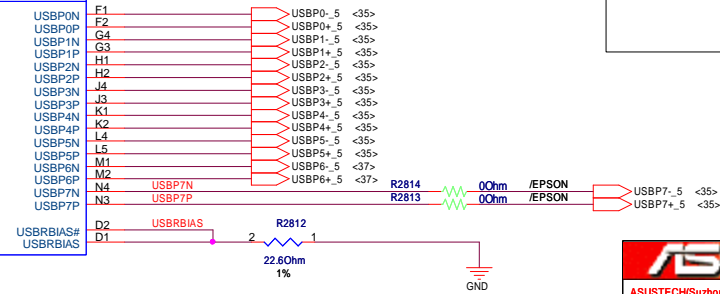
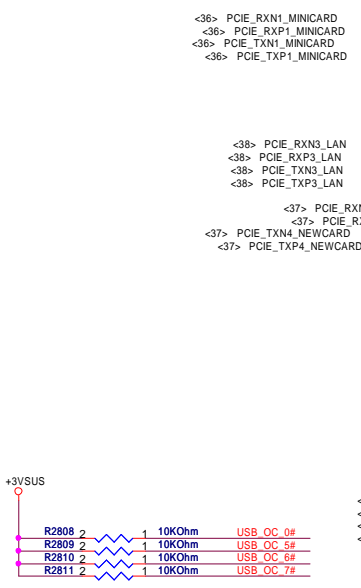

P/N: 02G010008811

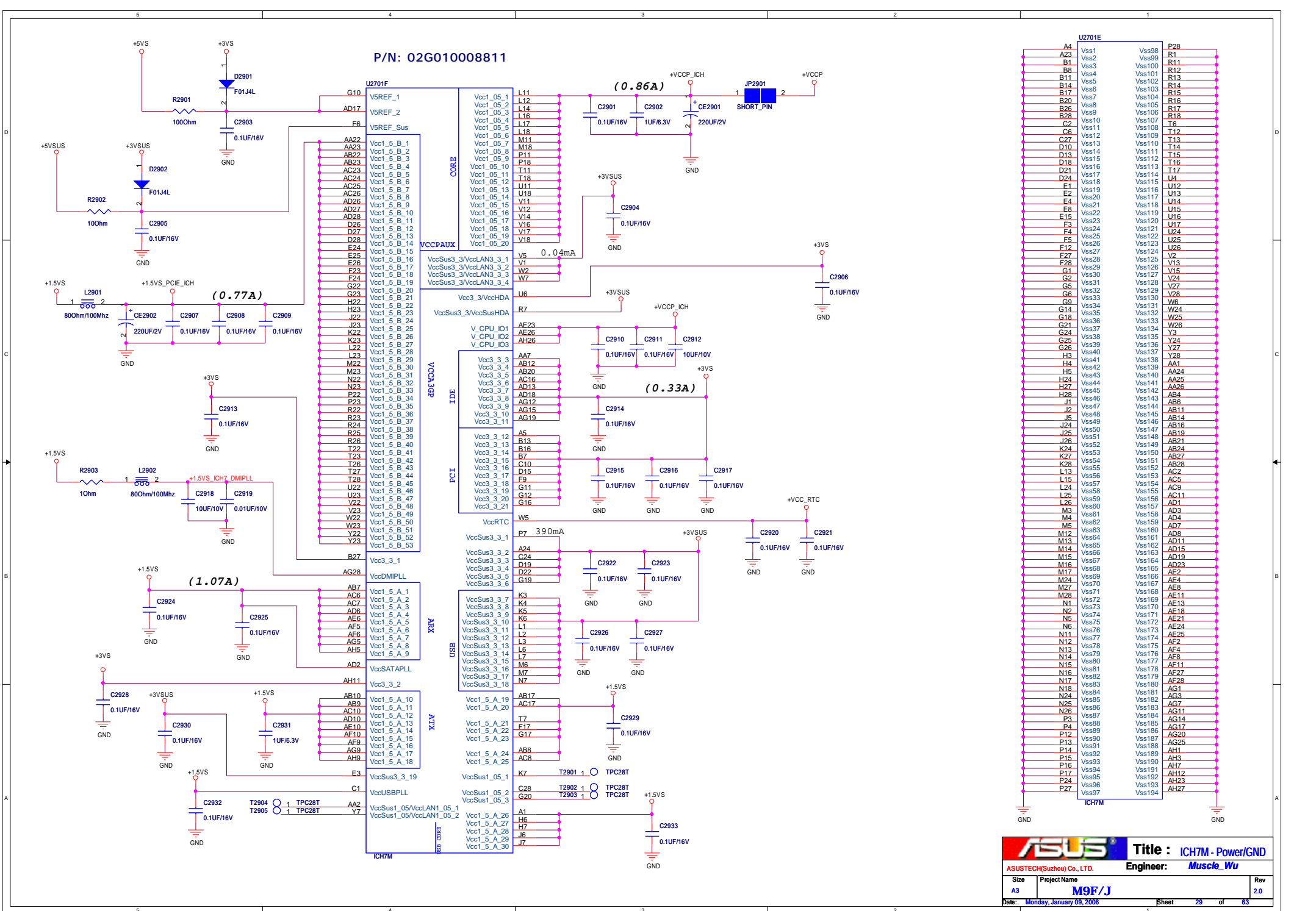

U2701E		
A4	Vss1	Vss98
A23	Vss2	R1
B1	Vss3	Vss100
B9	Vss4	R11
B11	Vss5	R12
B14	Vss6	R13
B17	Vss7	Vss102
B20	Vss8	R14
B26	Vss9	Vss103
B28	Vss10	Vss104
C2	Vss11	R15
C6	Vss12	R16
C27	Vss13	Vss105
D10	Vss14	R17
D13	Vss15	Vss106
D18	Vss16	T6
D21	Vss17	Vss107
D24	Vss18	Vss108
F3	Vss19	Vss109
E2	Vss20	T12
E4	Vss21	Vss110
E8	Vss22	T14
E15	Vss23	Vss112
F4	Vss24	T16
F5	Vss25	Vss113
F12	Vss26	Vss114
F27	Vss27	Vss115
F29	Vss28	U4
G1	Vss29	Vss116
G2	Vss30	Vss117
G5	Vss31	Vss118
G6	Vss32	Vss119
G9	Vss33	Vss120
G14	Vss34	U12
G18	Vss35	U13
G21	Vss36	Vss121
G24	Vss37	U14
G25	Vss38	Vss122
G28	Vss39	Vss123
H3	Vss40	U16
H4	Vss41	Vss124
H5	Vss42	V2
H28	Vss43	Vss125
H32	Vss44	Vss126
J1	Vss45	V24
J2	Vss46	Vss127
J5	Vss47	Vss128
J24	Vss48	Vss129
J25	Vss49	V28
J26	Vss50	W2
K24	Vss51	Vss132
K27	Vss52	Vss133
K28	Vss53	W25
L13	Vss54	Vss134
L15	Vss55	Y3
L24	Vss56	Vss135
L25	Vss57	Y24
M3	Vss58	Y27
M4	Vss59	Vss137
M5	Vss60	Vss138
M12	Vss61	Vss139
M13	Vss62	Vss140
M14	Vss63	AA24
M15	Vss64	AA25
M16	Vss65	AA26
M17	Vss66	AB4
M24	Vss67	AB6
M27	Vss68	AB11
M28	Vss69	AB14
N1	Vss70	AB16
N2	Vss71	AB19
N5	Vss72	AB21
N6	Vss73	AB24
N7	Vss74	AB27
N11	Vss75	AB28
N12	Vss76	AC2
N13	Vss77	AC5
N14	Vss78	AC9
N15	Vss79	AD1
N16	Vss80	AD3
N17	Vss81	AD4
N18	Vss82	AD7
N24	Vss83	AD11
N25	Vss84	AD15
N26	Vss85	AD19
N28	Vss86	AD23
N3	Vss87	AE2
N4	Vss88	AE4
N11	Vss89	AE8
N12	Vss90	AE11
N13	Vss91	AE13
N14	Vss92	AE18
N15	Vss93	AE21
N16	Vss94	AE24
N17	Vss95	AF2
N18	Vss96	AF4
N19	Vss97	AF7
N20	Vss98	AF11
N21	Vss99	AF17
N22	Vss100	AF27
N23	Vss101	AF28
N24	Vss102	AG1
N25	Vss103	AG3
N26	Vss104	AG7
N27	Vss105	AG11
N28	Vss106	AG14
N29	Vss107	AG17
N30	Vss108	AG20
N31	Vss109	AG25
N32	Vss110	AH1
N33	Vss111	AH3
N34	Vss112	AH7
N35	Vss113	AH12
N36	Vss114	AH23
N37	Vss115	AH27
N38	Vss116	
N39	Vss117	
N40	Vss118	
N41	Vss119	
N42	Vss120	

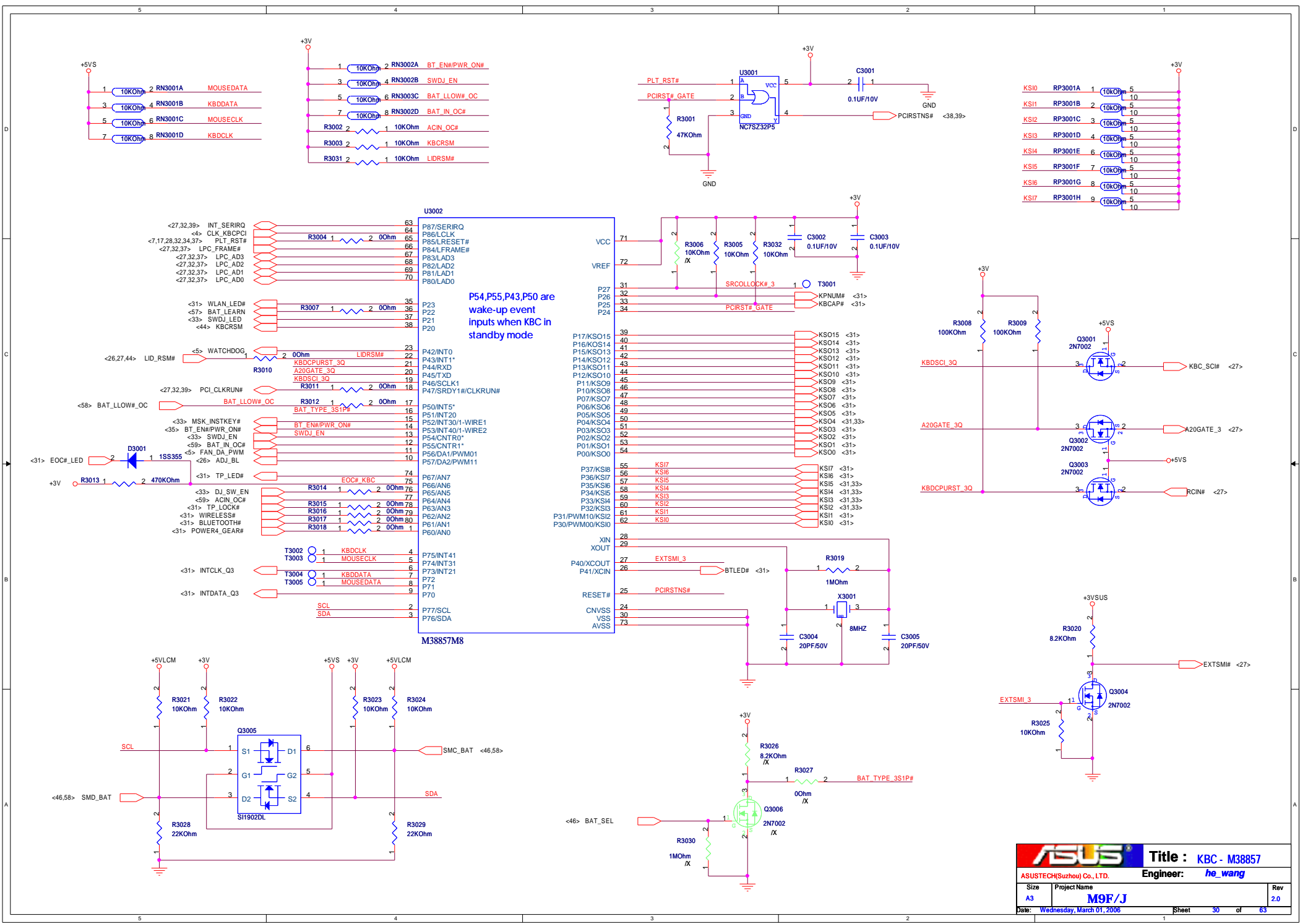

Keyboard
P/N: 12G182402404

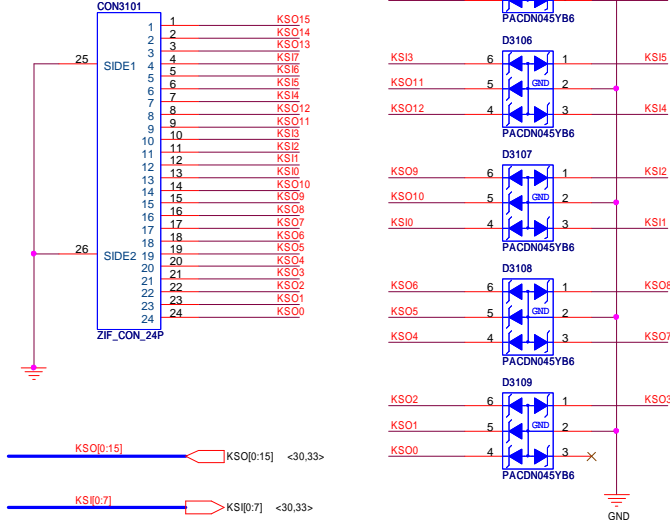

Touch Pad
P/N: 12G183101206

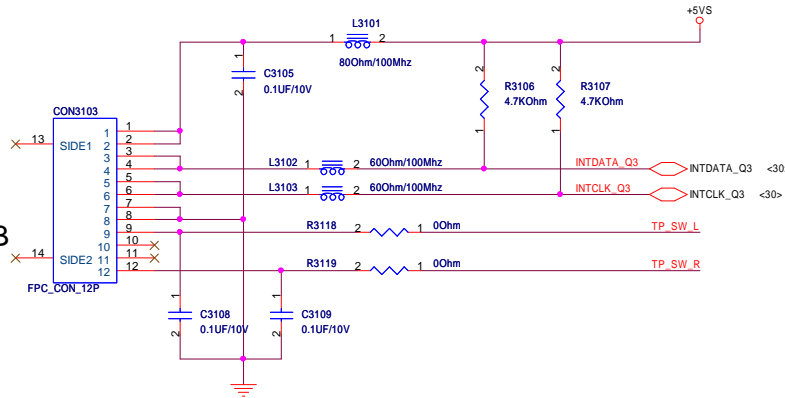

Touch Pad Button
P/N: 12G091031040

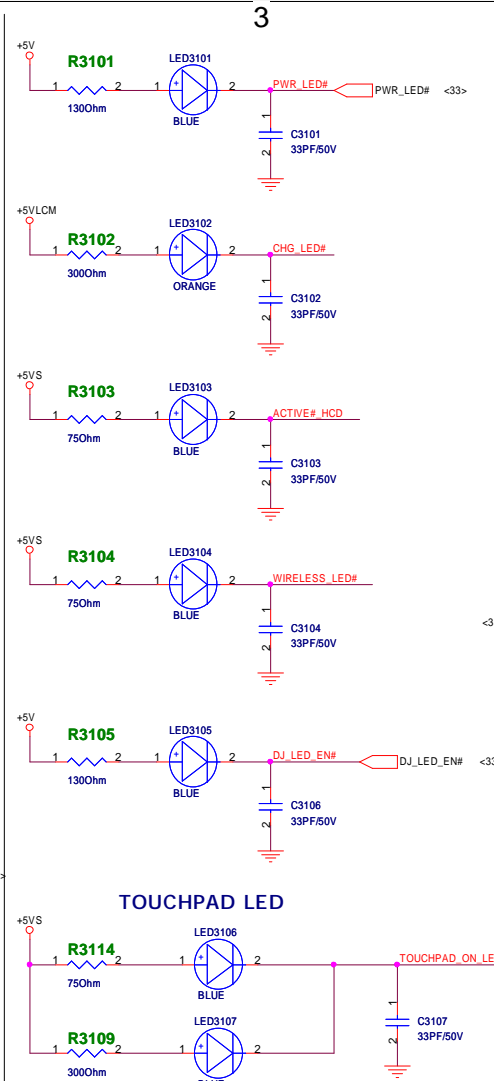
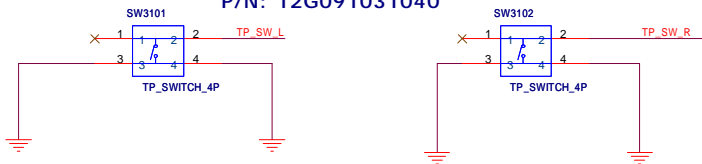

TOUCHPAD LED

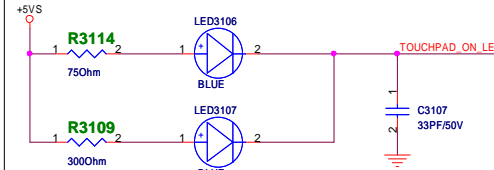

Instant Key Board Connector
P/N: 12G183101409

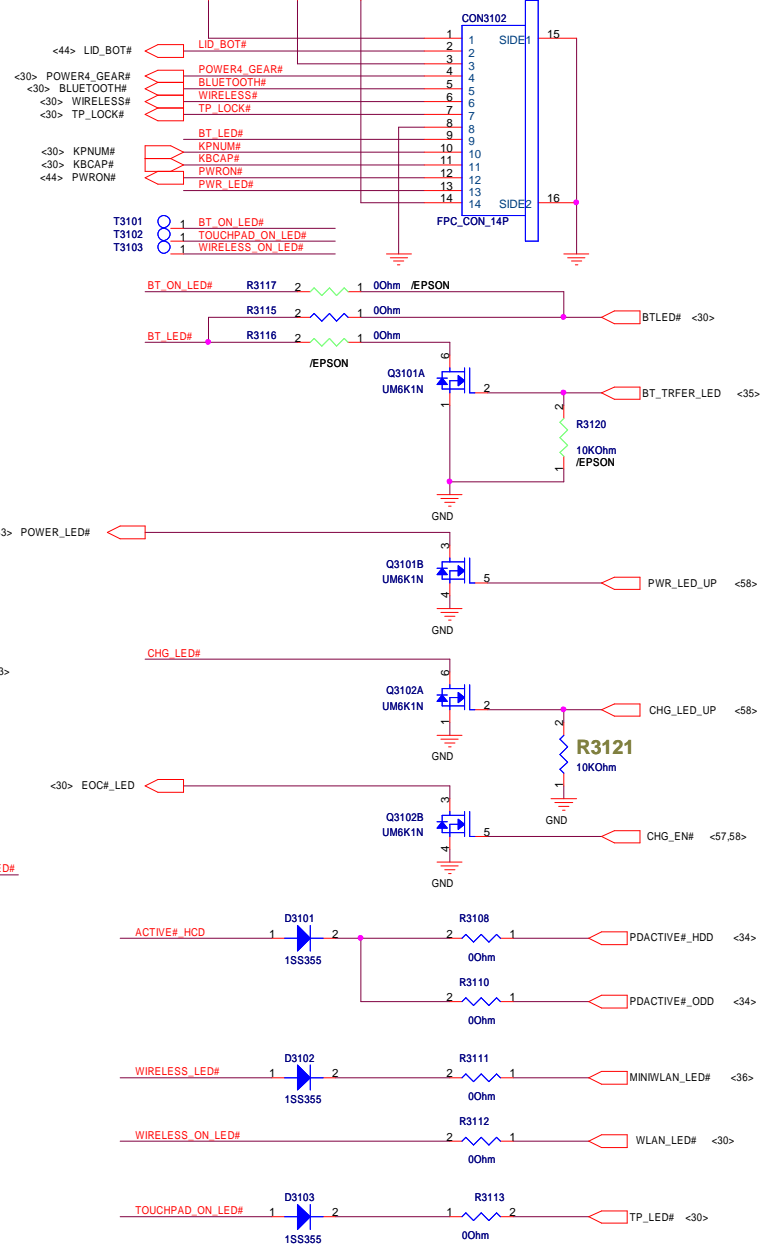

TPM CON

P/N: 12G16080020J

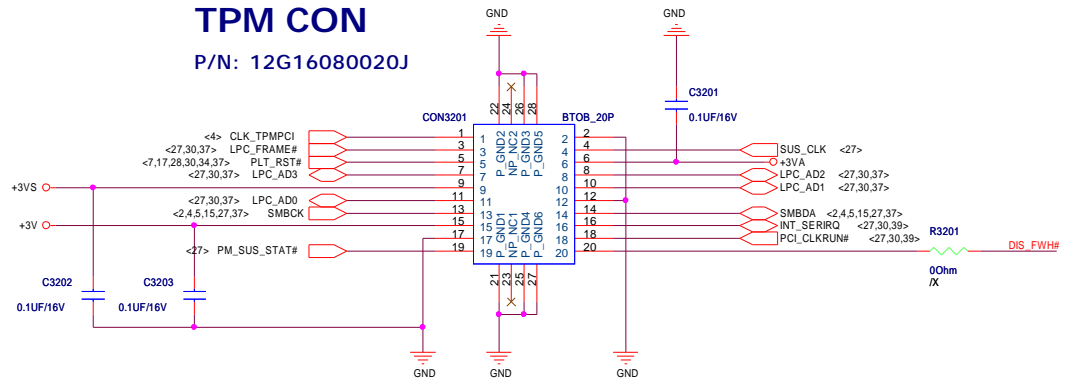

FWH

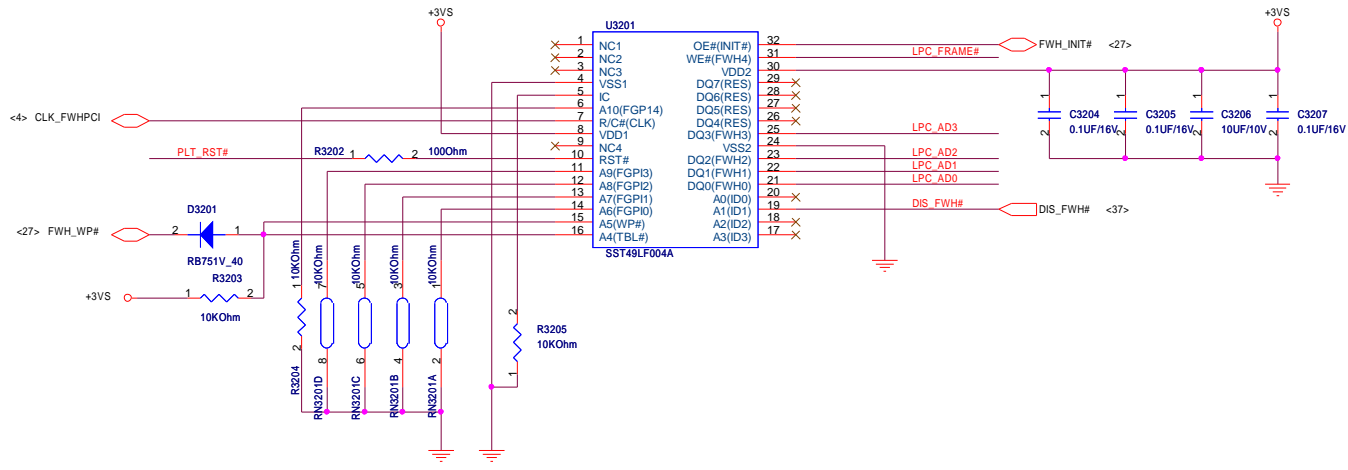

DEBUG PORT (CONNECT WITH FFC)

P/N: 12G183101206

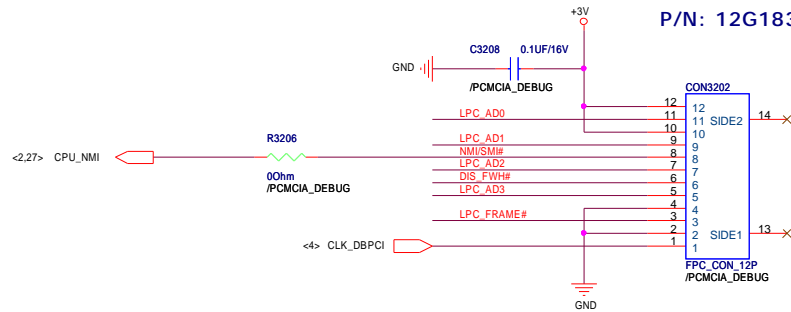

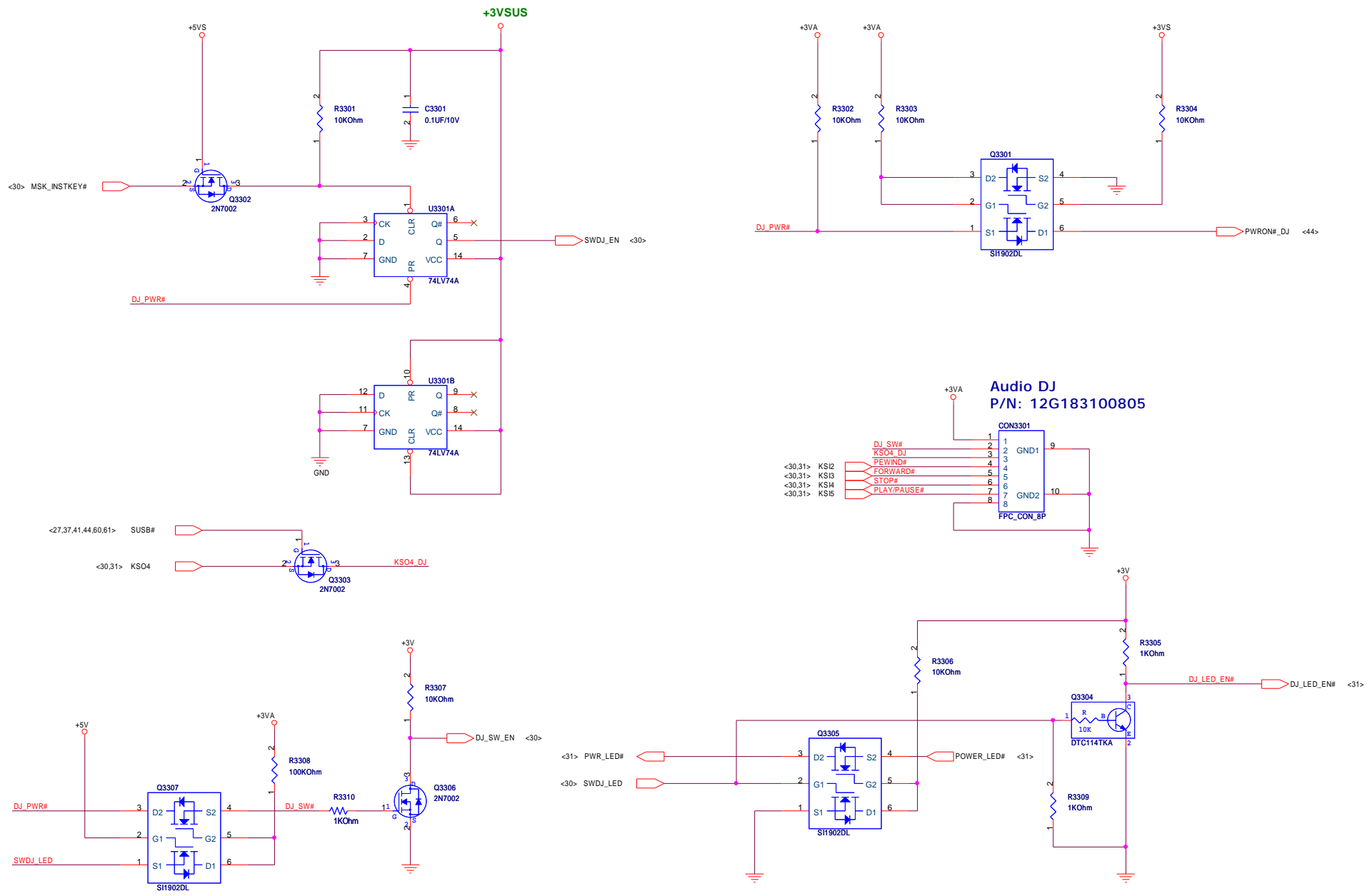

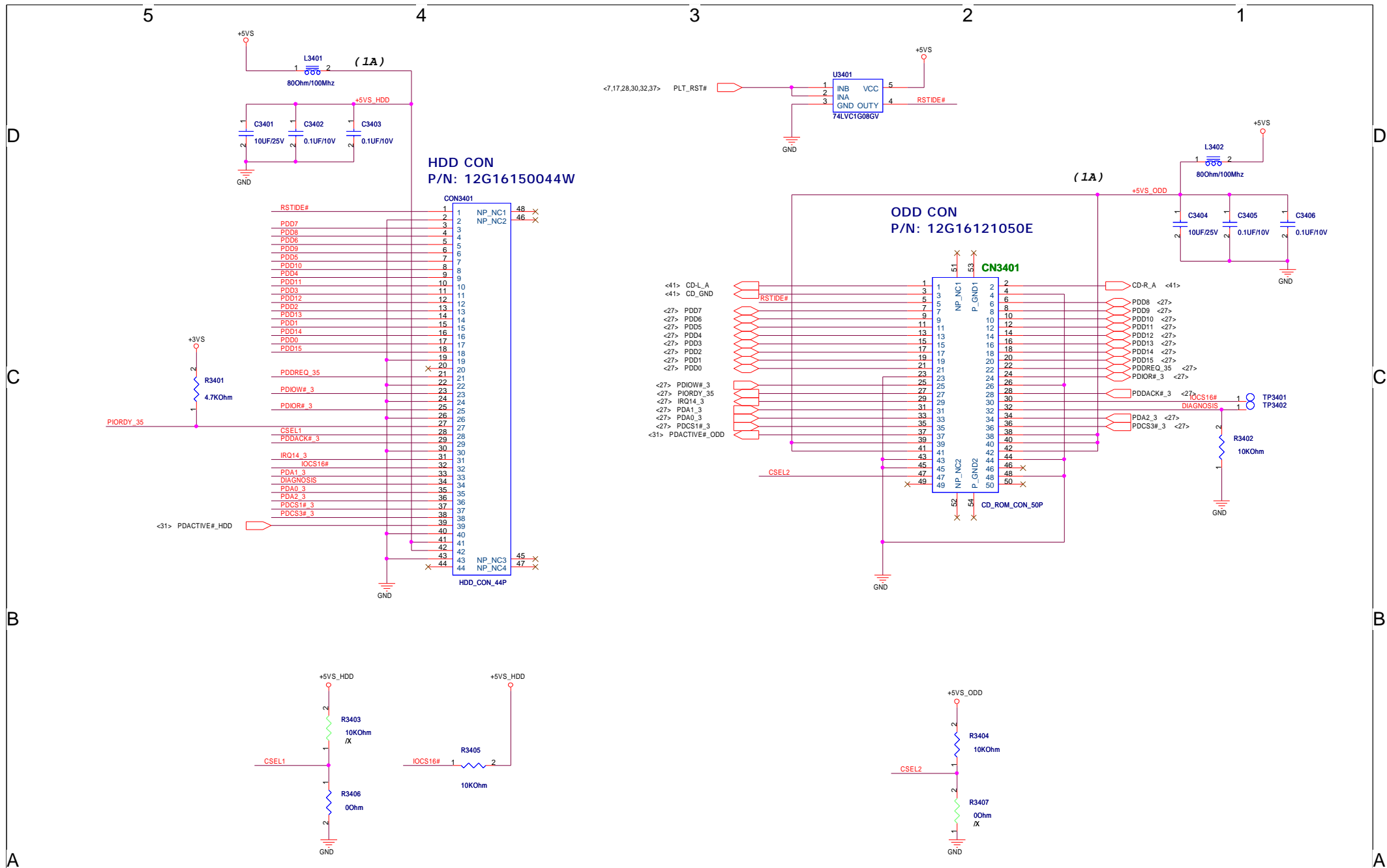

5

4

3

2

1

D

D

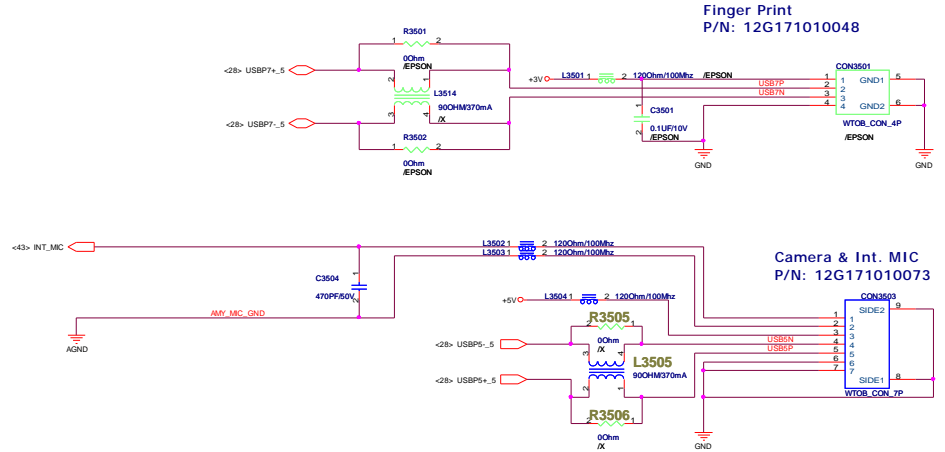
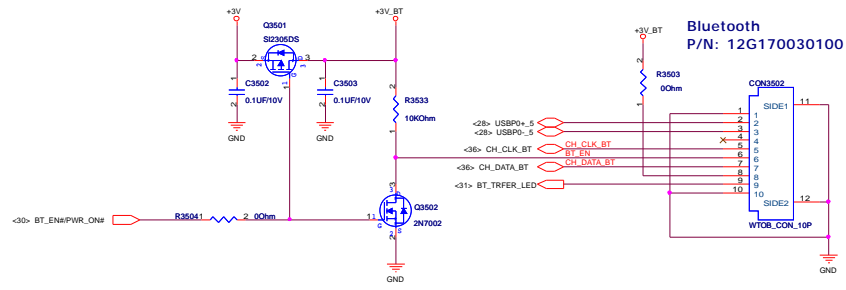

C

C

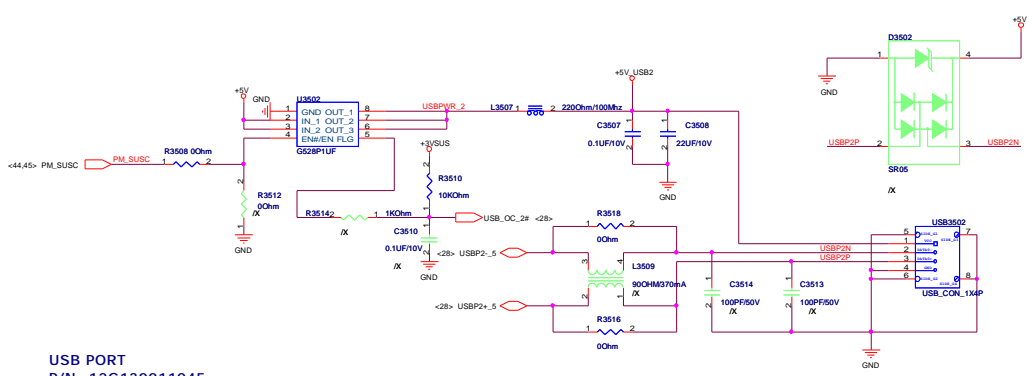
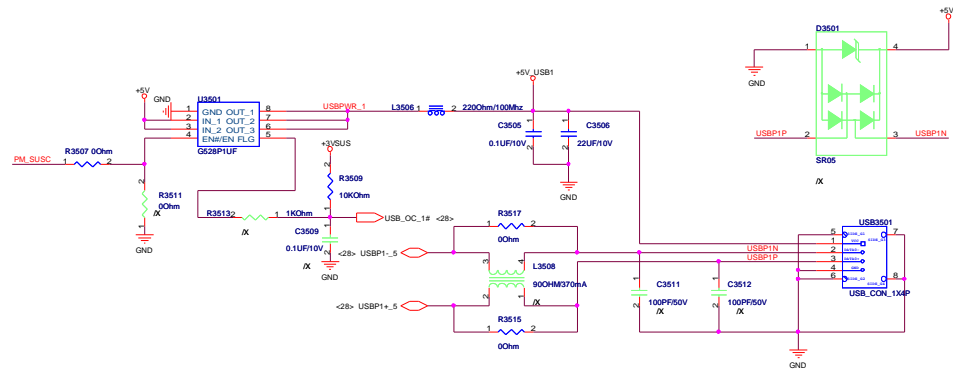

B

B

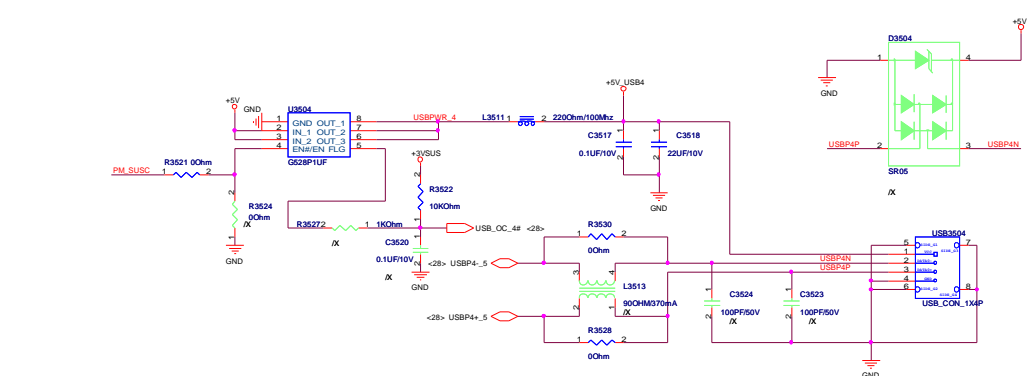
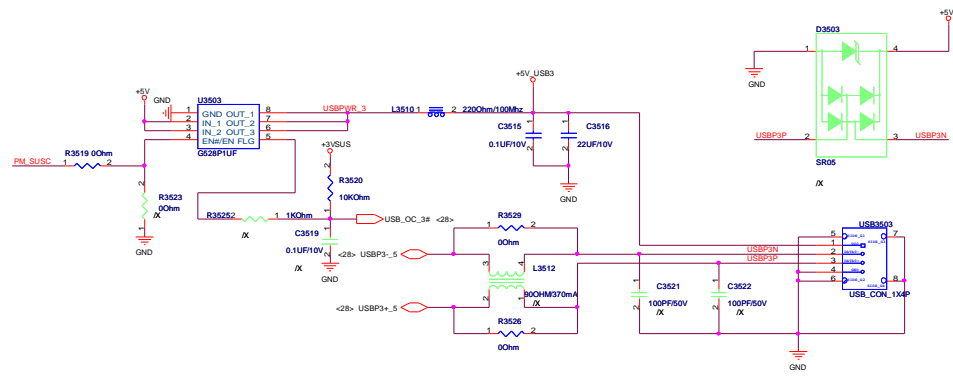

A

A

5

4

3

2

1

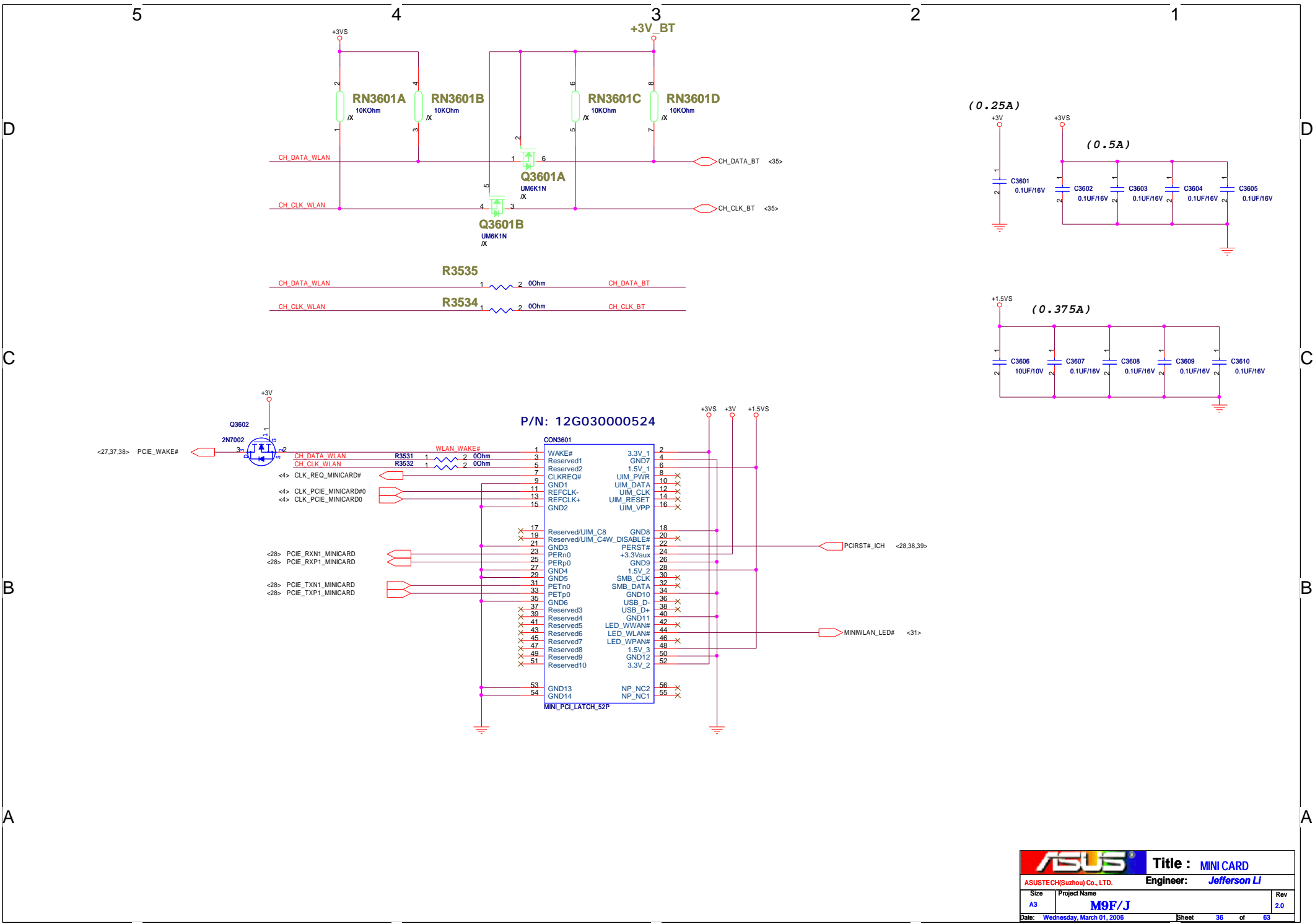

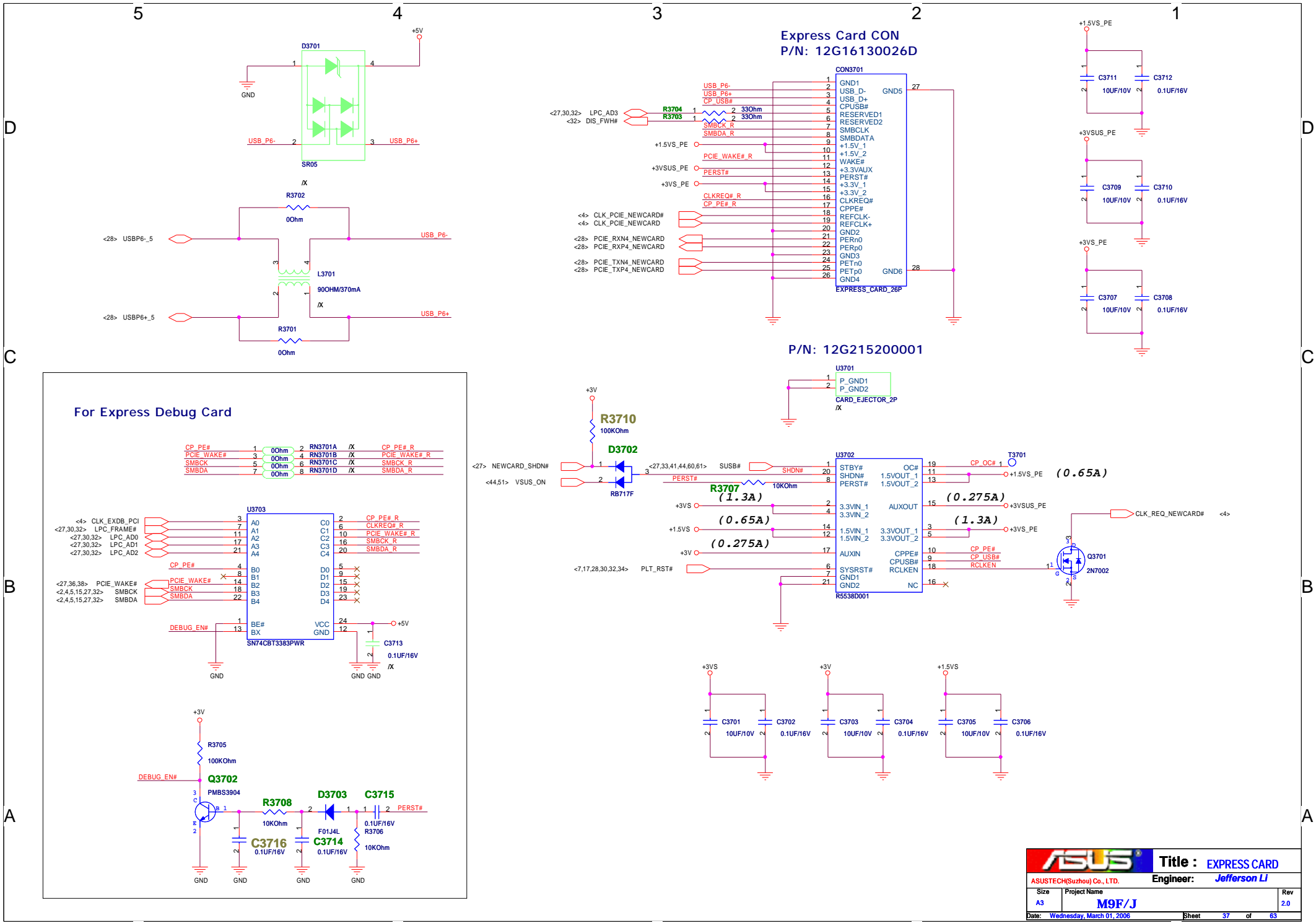

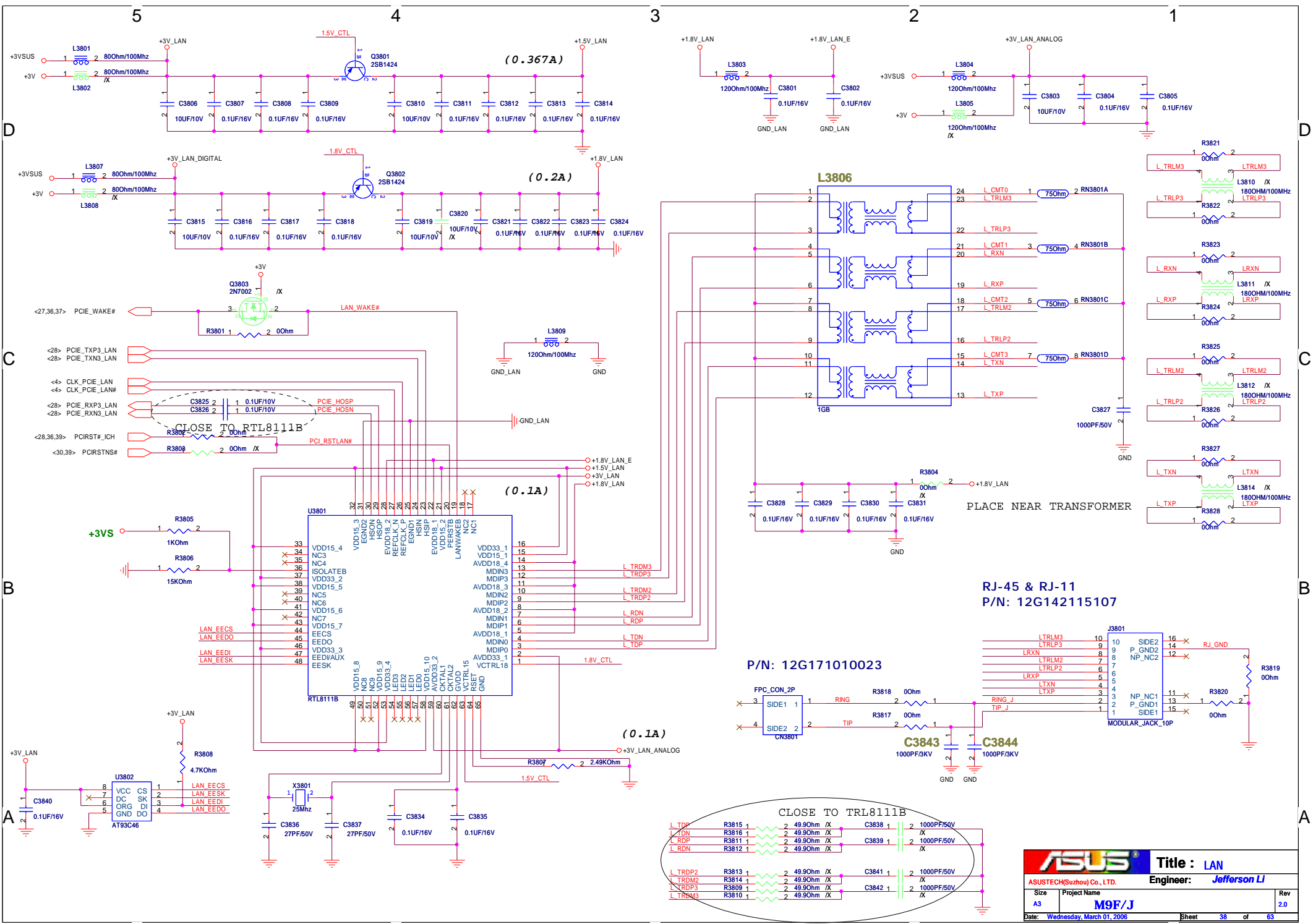

CLOSE TO RTL8111B

L TRDP2	R3813	1	2	49.90hm	/X	C3841	1	2	1000PF/50V
L TRDP3	R3814	1	2	49.90hm	/X	C3842	1	2	1000PF/50V
L TRDM3	R3809	1	2	49.90hm	/X	C3838	1	2	1000PF/50V
L TRDM2	R3810	1	2	49.90hm	/X	C3839	1	2	1000PF/50V

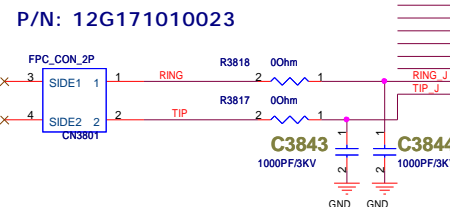
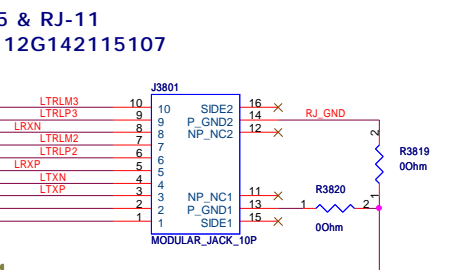

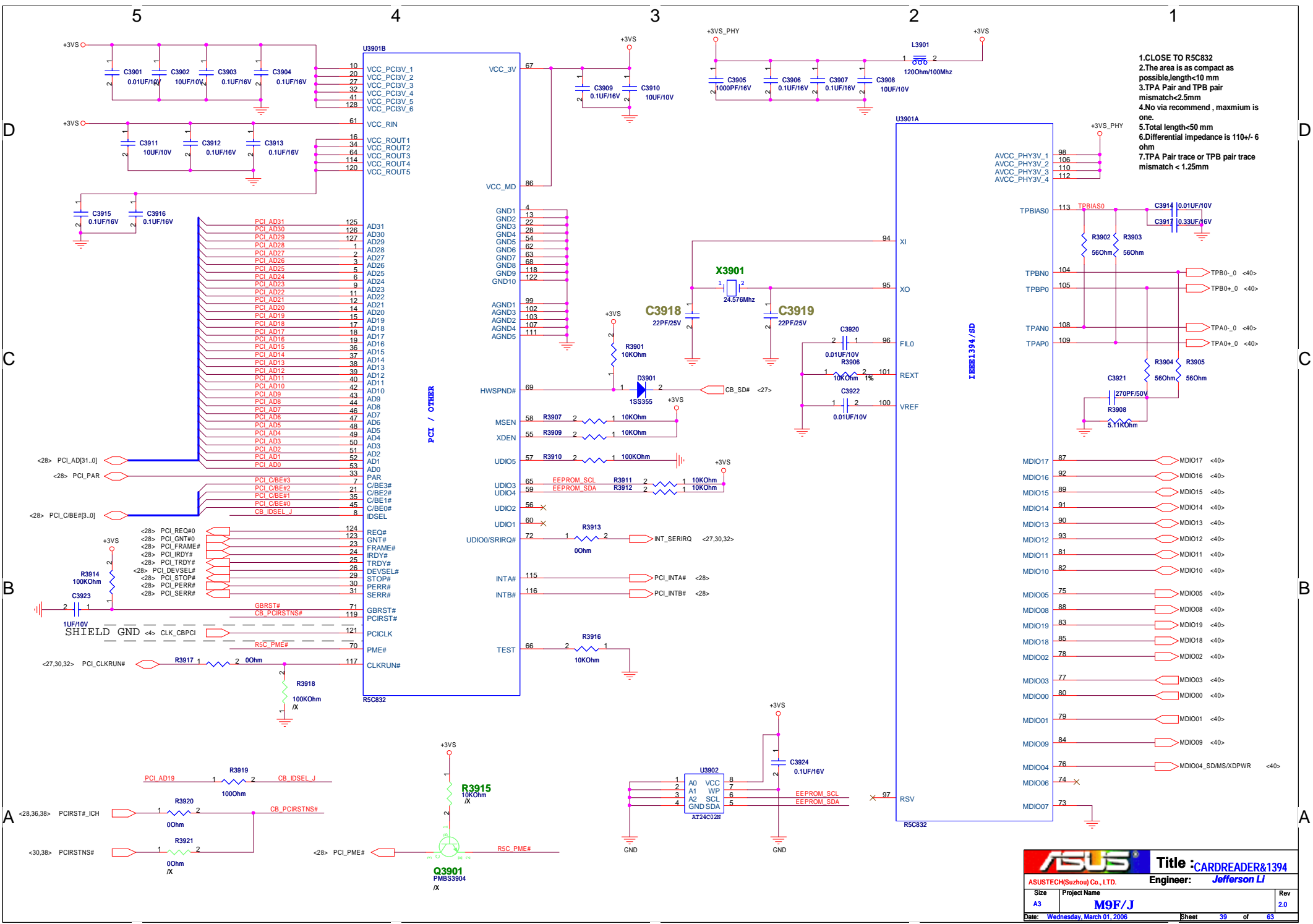

1. CLOSE TO R5C832
2. The area is as compact as possible, length < 10 mm
3. TPA Pair and TPB pair mismatch < 2.5mm
4. No via recommend, maximum is one.
5. Total length < 50 mm
6. Differential impedance is 110 +/- 6 ohm
7. TPA Pair trace or TPB pair trace mismatch < 1.25mm

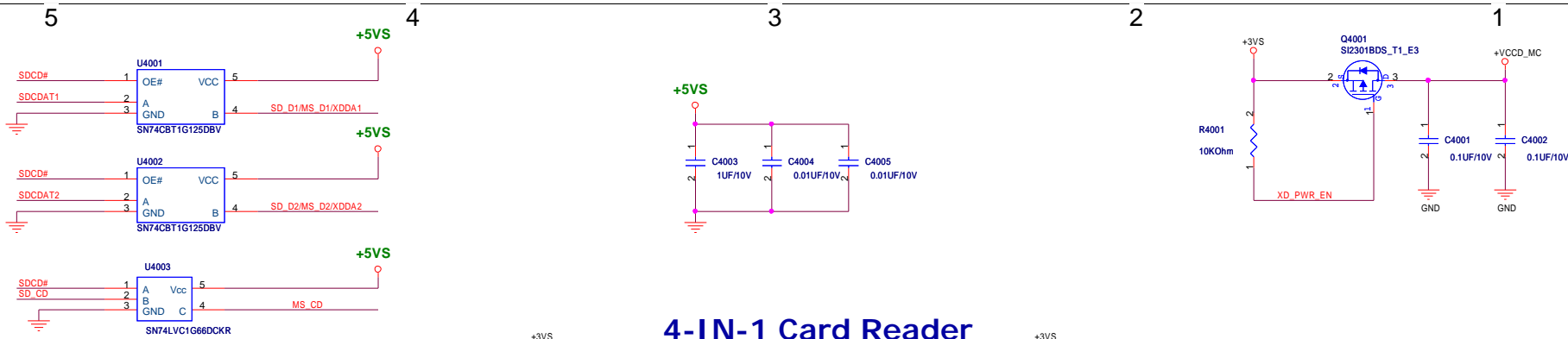

4-IN-1 Card Reader

P/N: 12G340004420

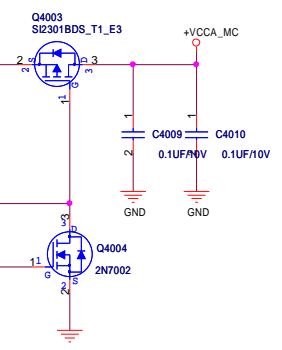
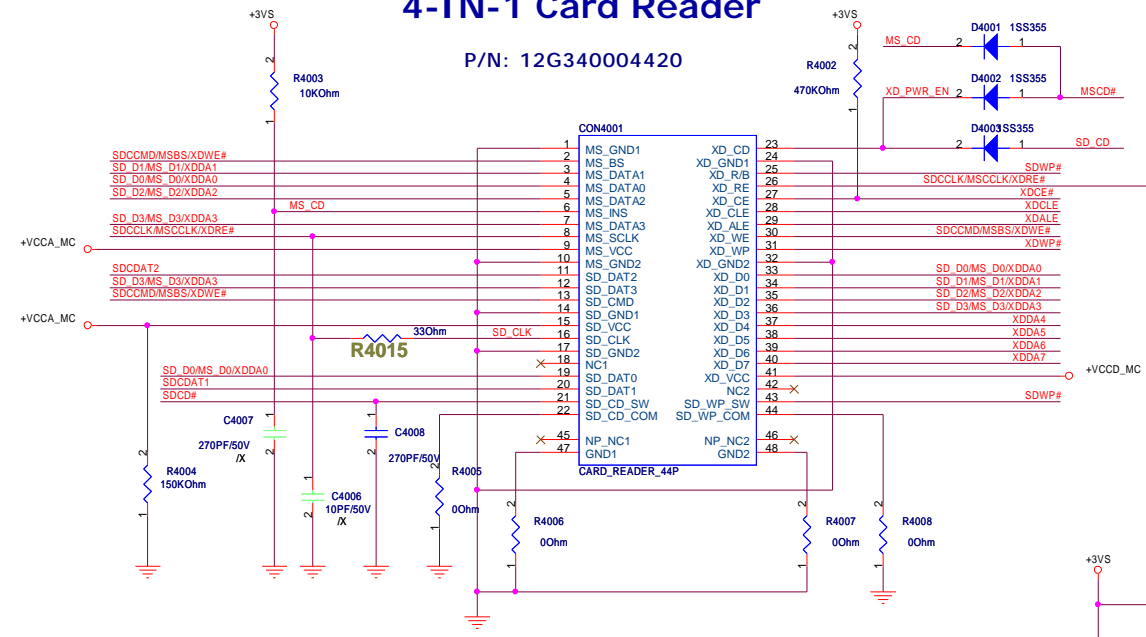
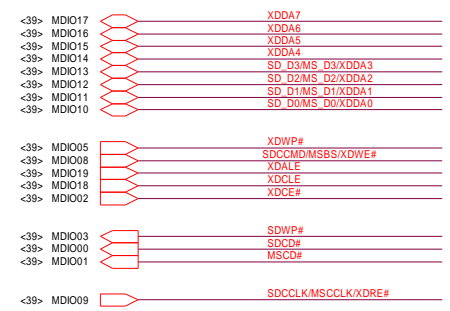

1394a CON

P/N: 12G130012043

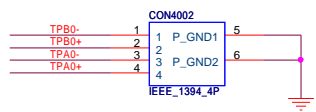
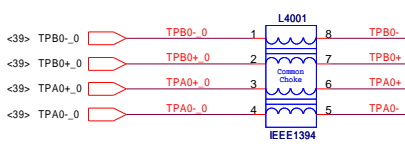

Modem CON

P/N: 12G161200120

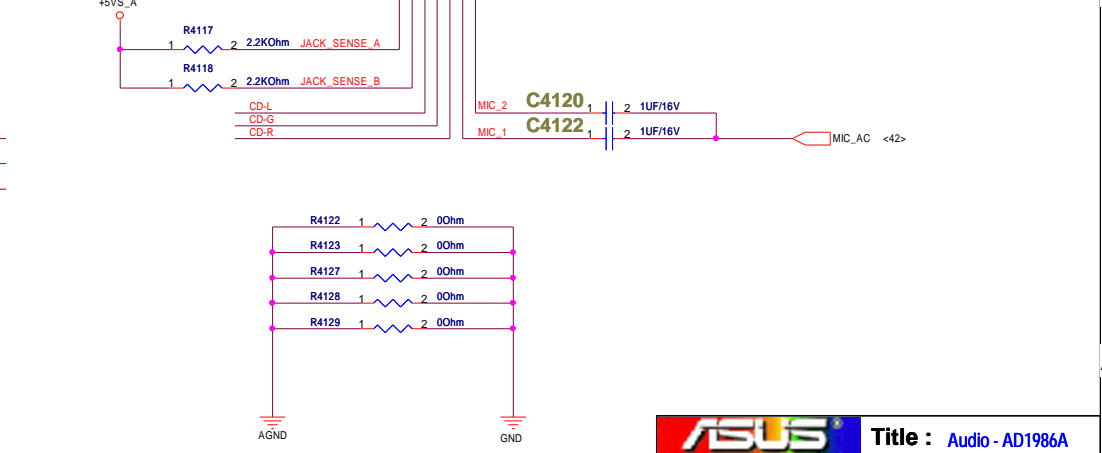
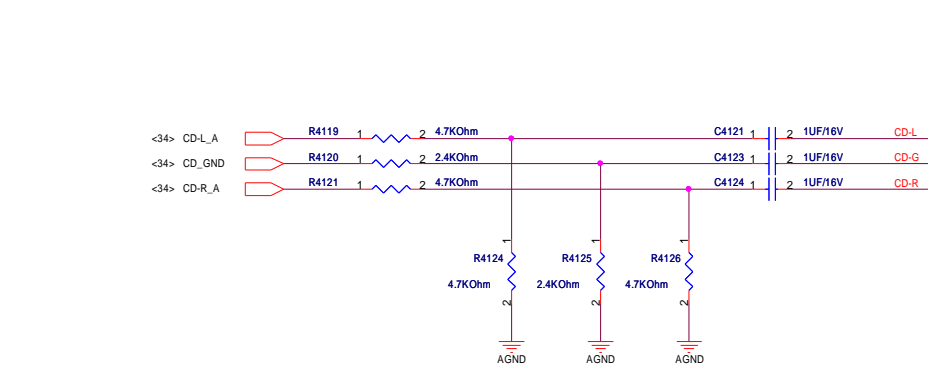
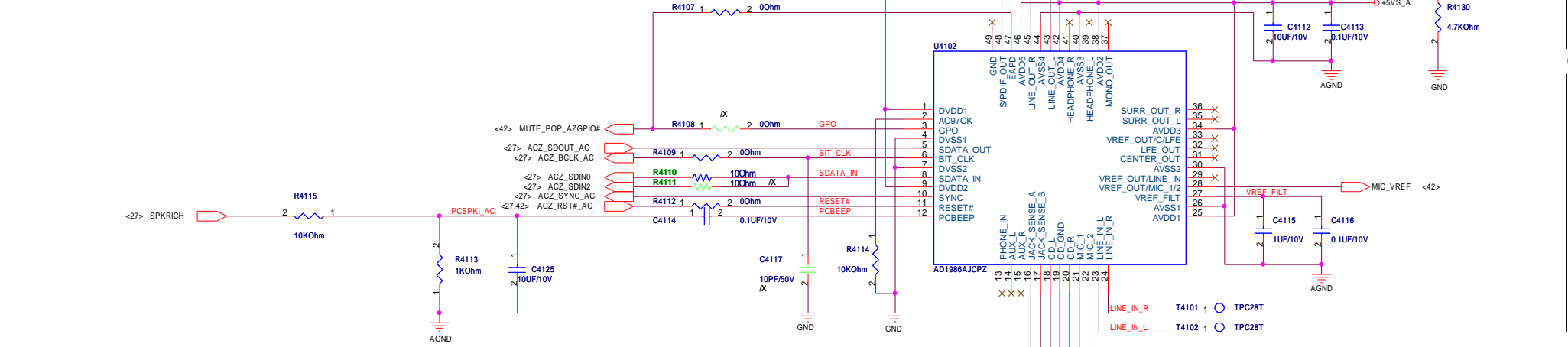
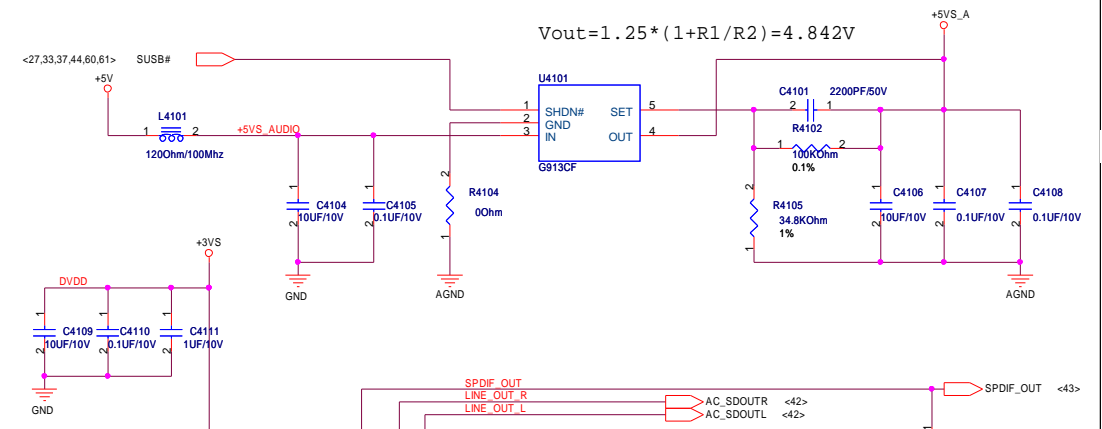
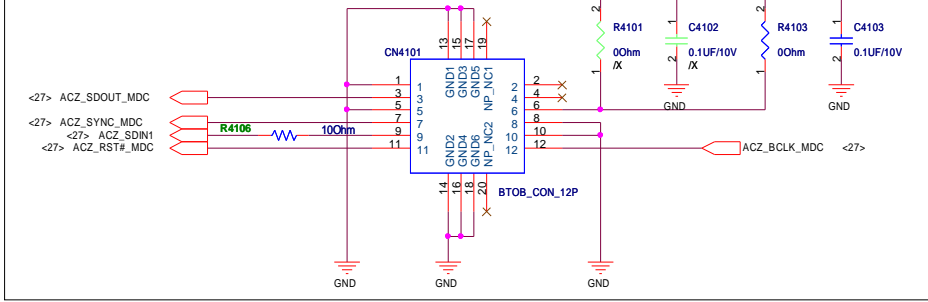

ASUS		Title : Audio - AD1986A	
ASUSTECH(Suzhou) Co., LTD.		Engineer: Muscle_Wu	
Size	Project Name		Rev
A3	M9F/J		2.0
Date: Thursday, March 02, 2006		Sheet	41 of 63

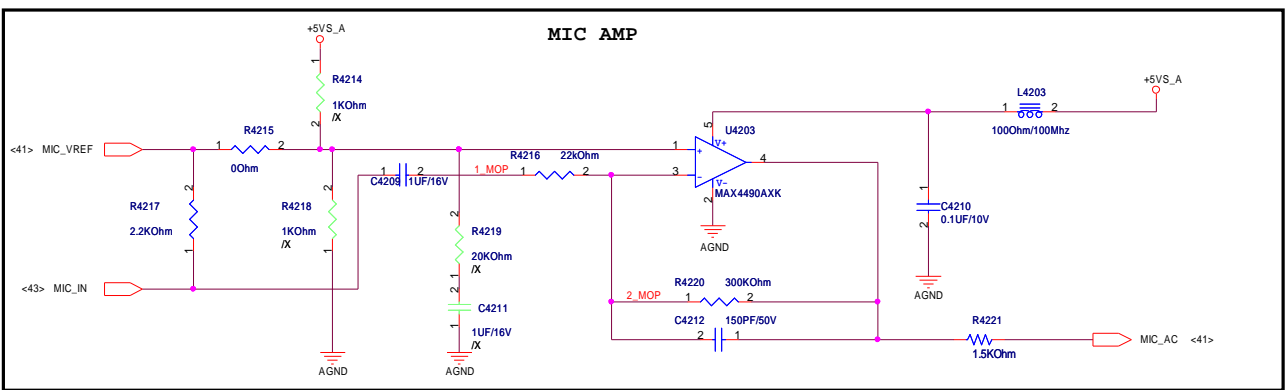
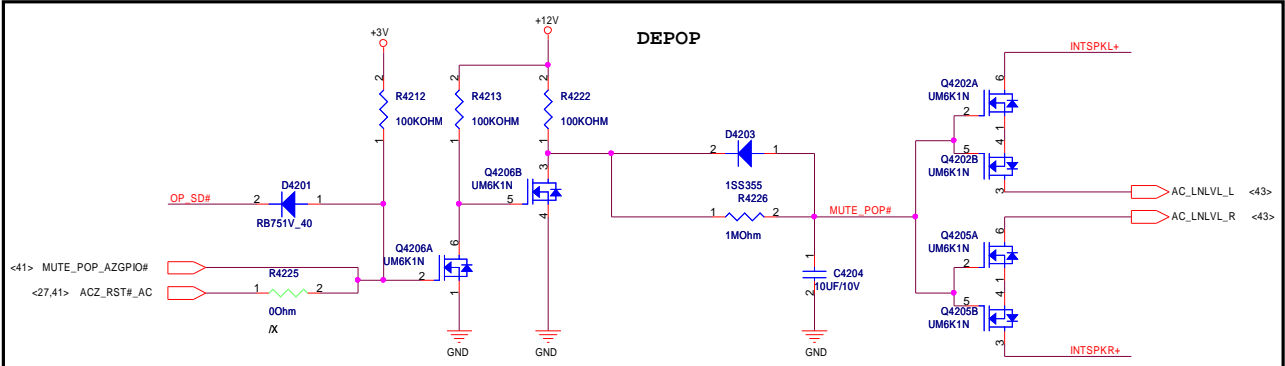
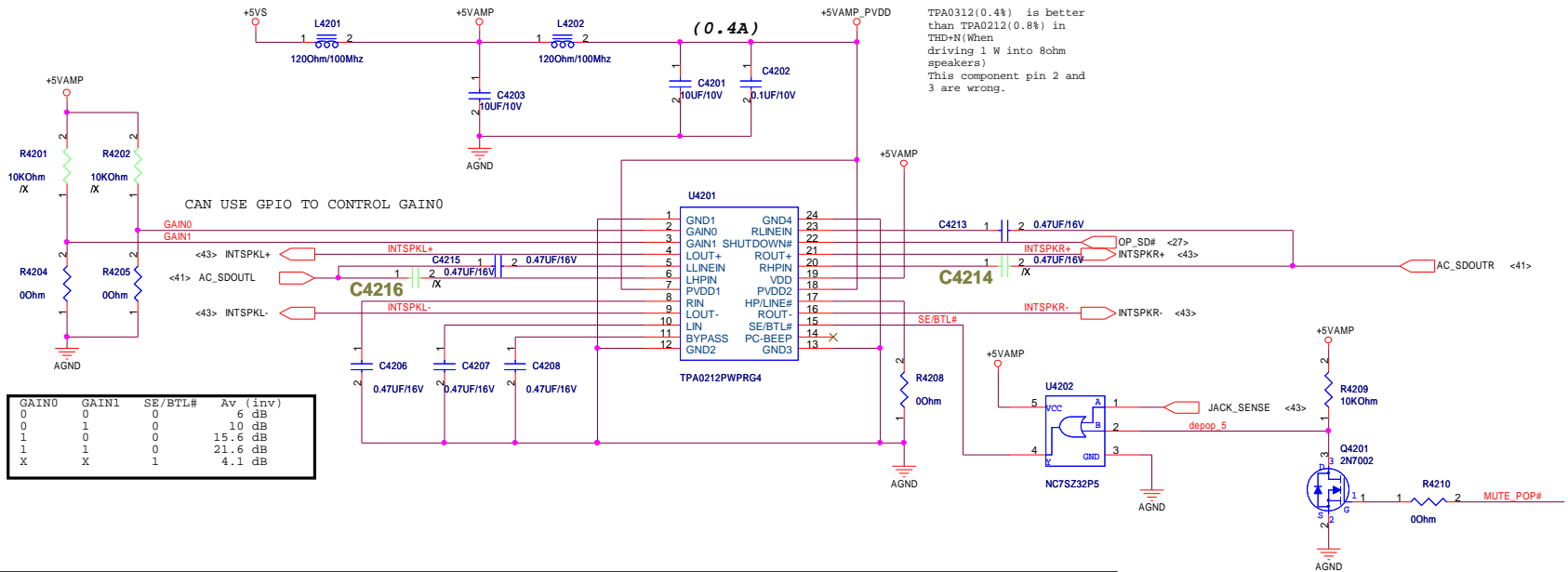

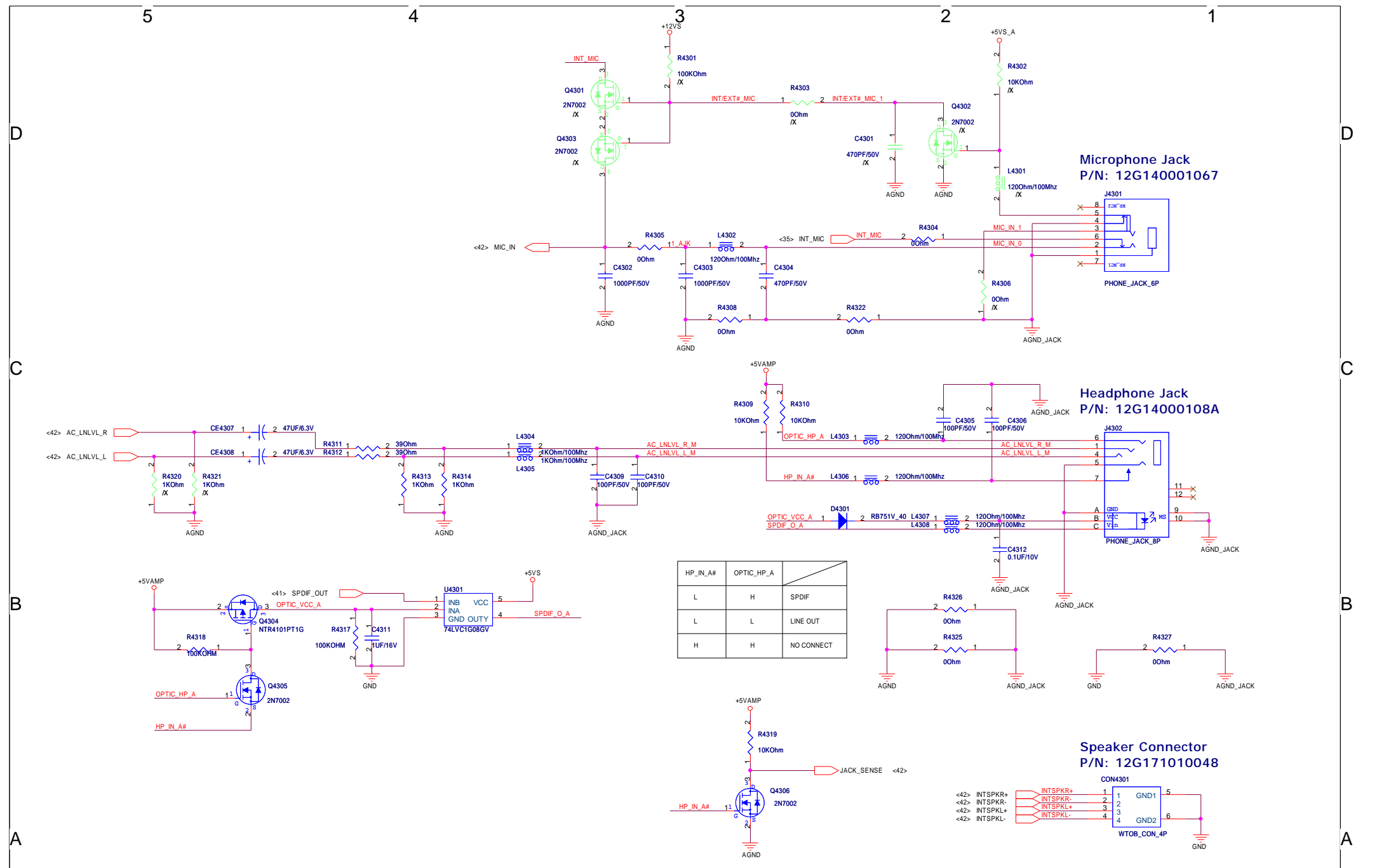

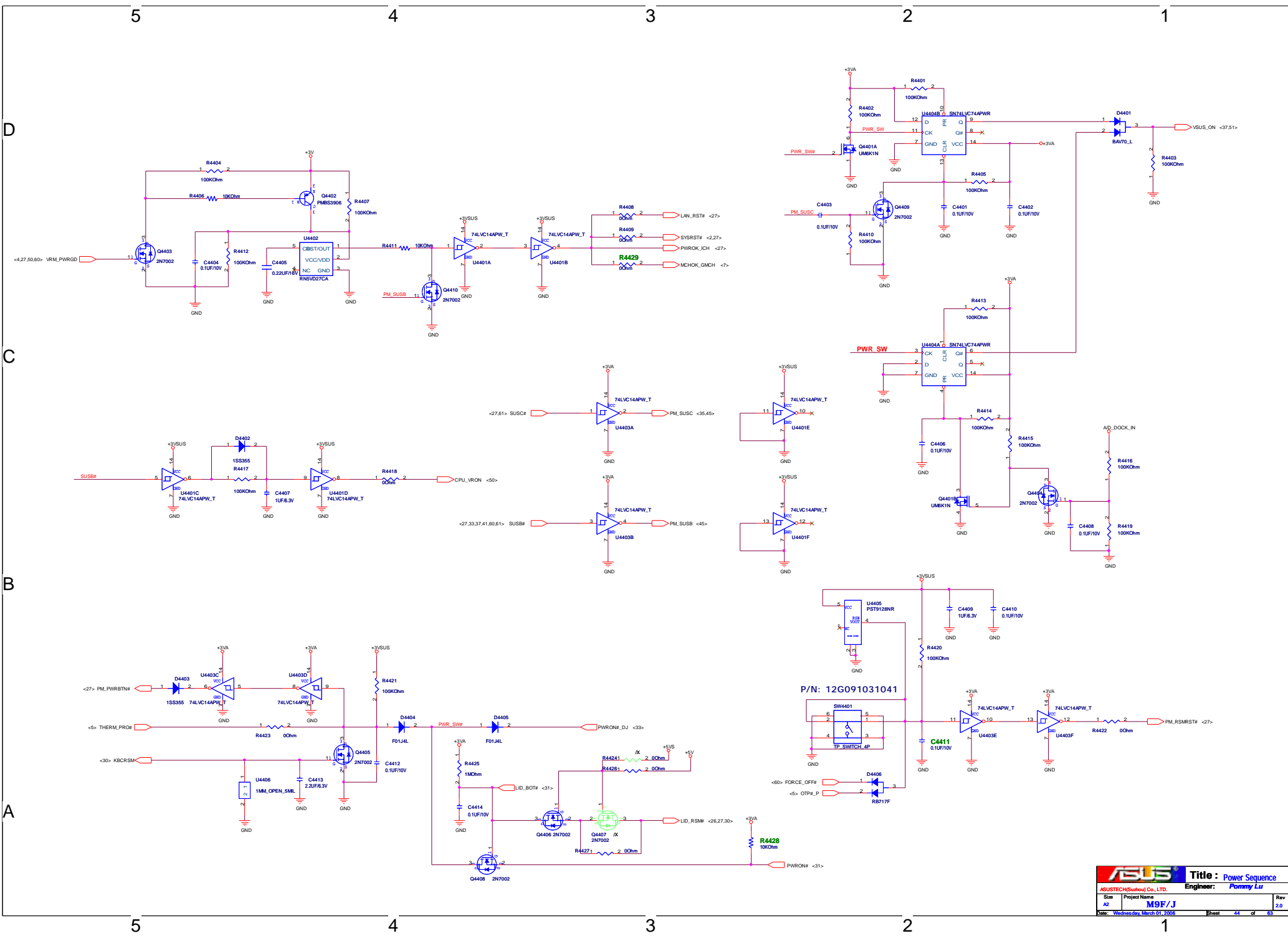

5

4

3

2

1

D

D

C

C

B

B

A

A

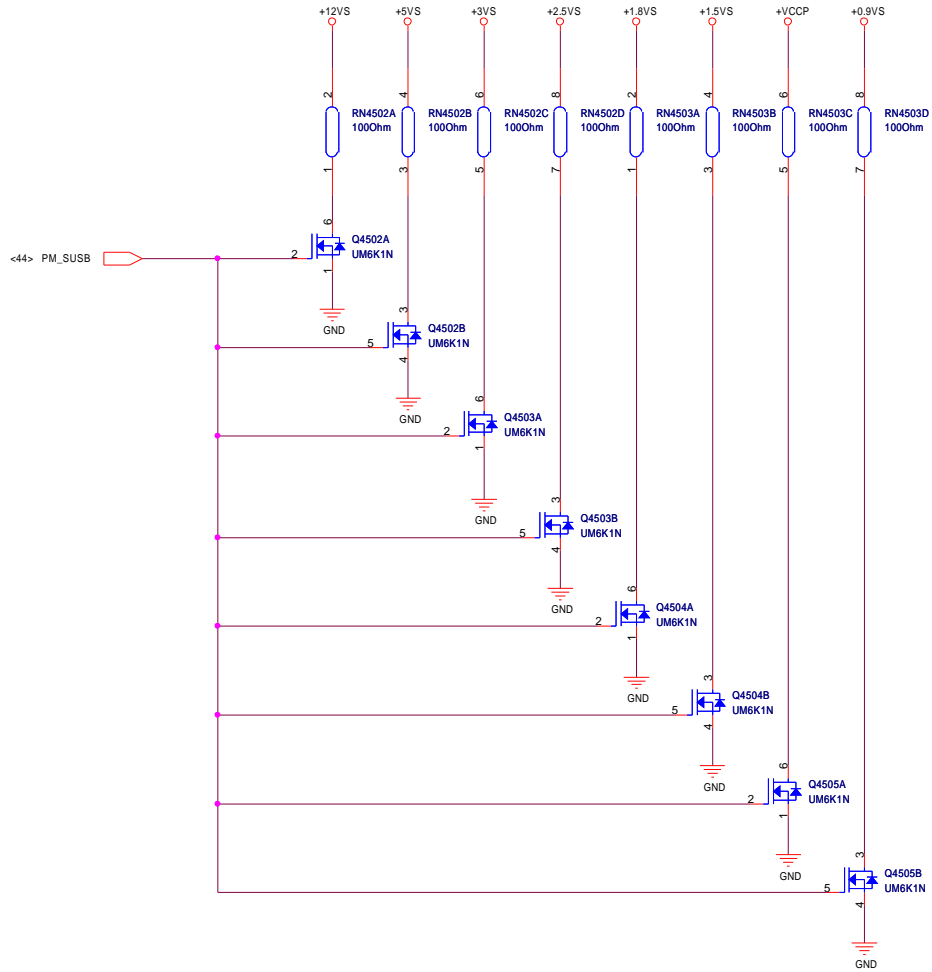
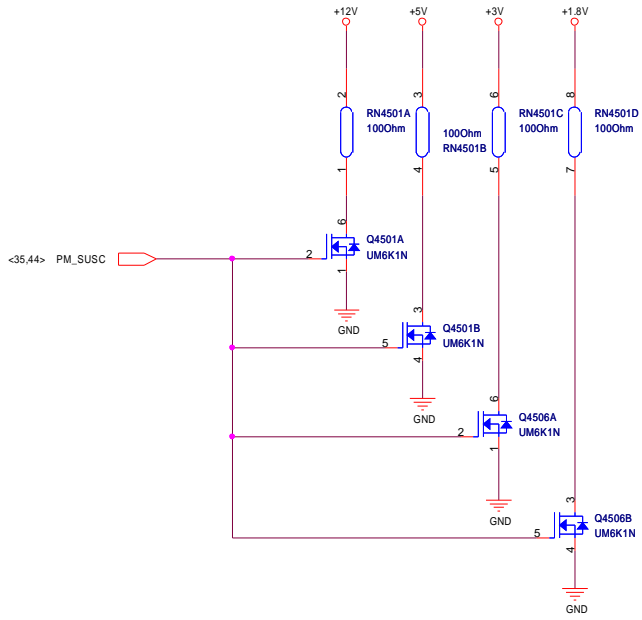

5

4

3

2

1

DC-IN

P/N: 12G14530103E

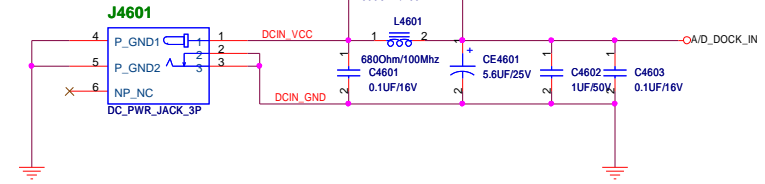

Battery-IN

P/N: 12G20001060B

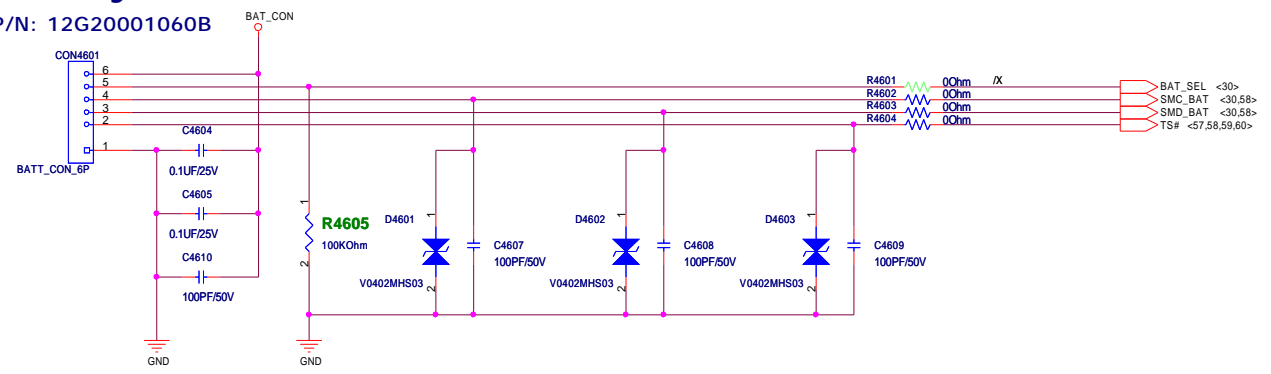

5

4

3

2

1

A

B

E

F

J

L

O

CPU Heat Sink Bracket Holes

Mini Card Latch Nuts

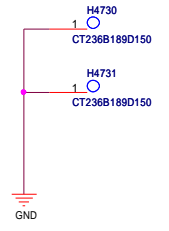
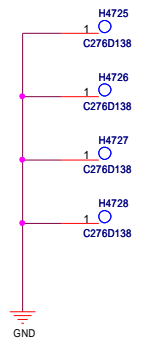
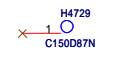
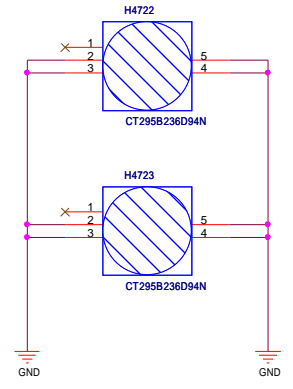
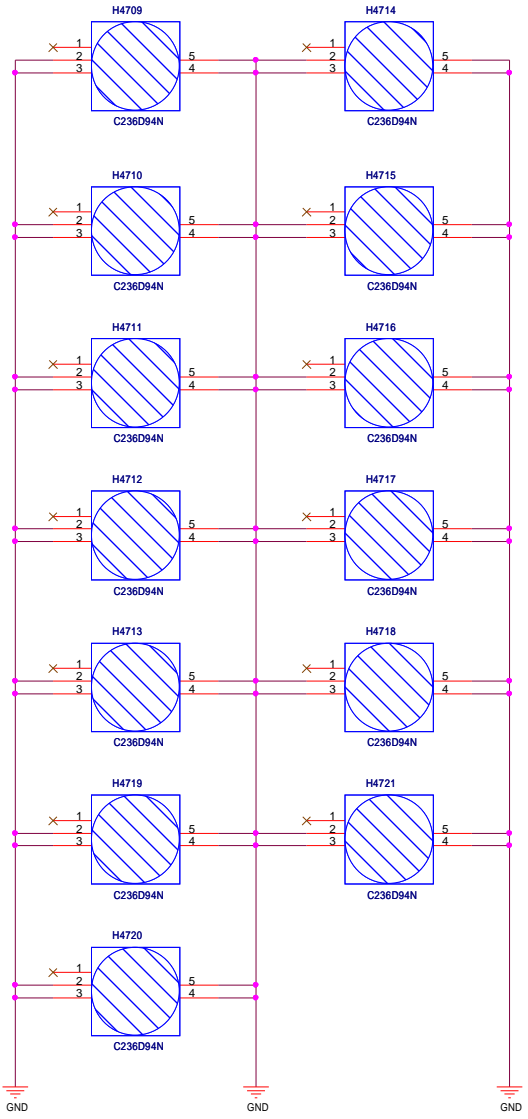
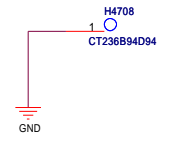
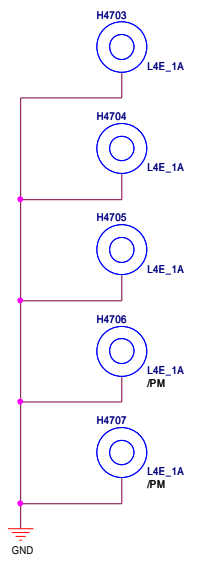
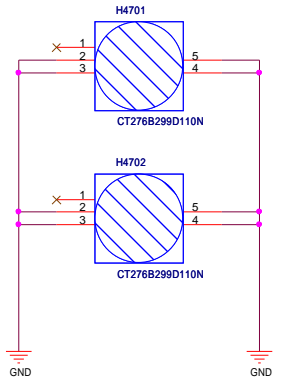

		Title : Screw Hole	
ASUSTECH(Suzhou) Co., LTD.		Engineer: Pommy Lu	
Size	Project Name	Rev	
A3	M9F/J	2.0	
Date: Thursday, February 23, 2006		Sheet	47 of 63

5

4

3

2

1

D

D

C

C

B

B

A

A

		Title : <i>Dummy</i>	
ASUSTECH(Suzhou) Co., LTD.		Engineer: <i>Dummy</i>	
Size	Project Name	Rev	
A3	M9F/J	2.0	
Date: <i>Monday, January 09, 2006</i>		Sheet	48 of 63

5

4

3

2

1

D

D

C

C

B

B

A

A

		Title : <i>Dummy</i>	
ASUSTECH(Suzhou) Co., LTD.		Engineer: <i>Dummy</i>	
Size	Project Name	Rev	
A3	M9F/J	2.0	
Date: <i>Monday, January 09, 2006</i>		Sheet	49 of 63

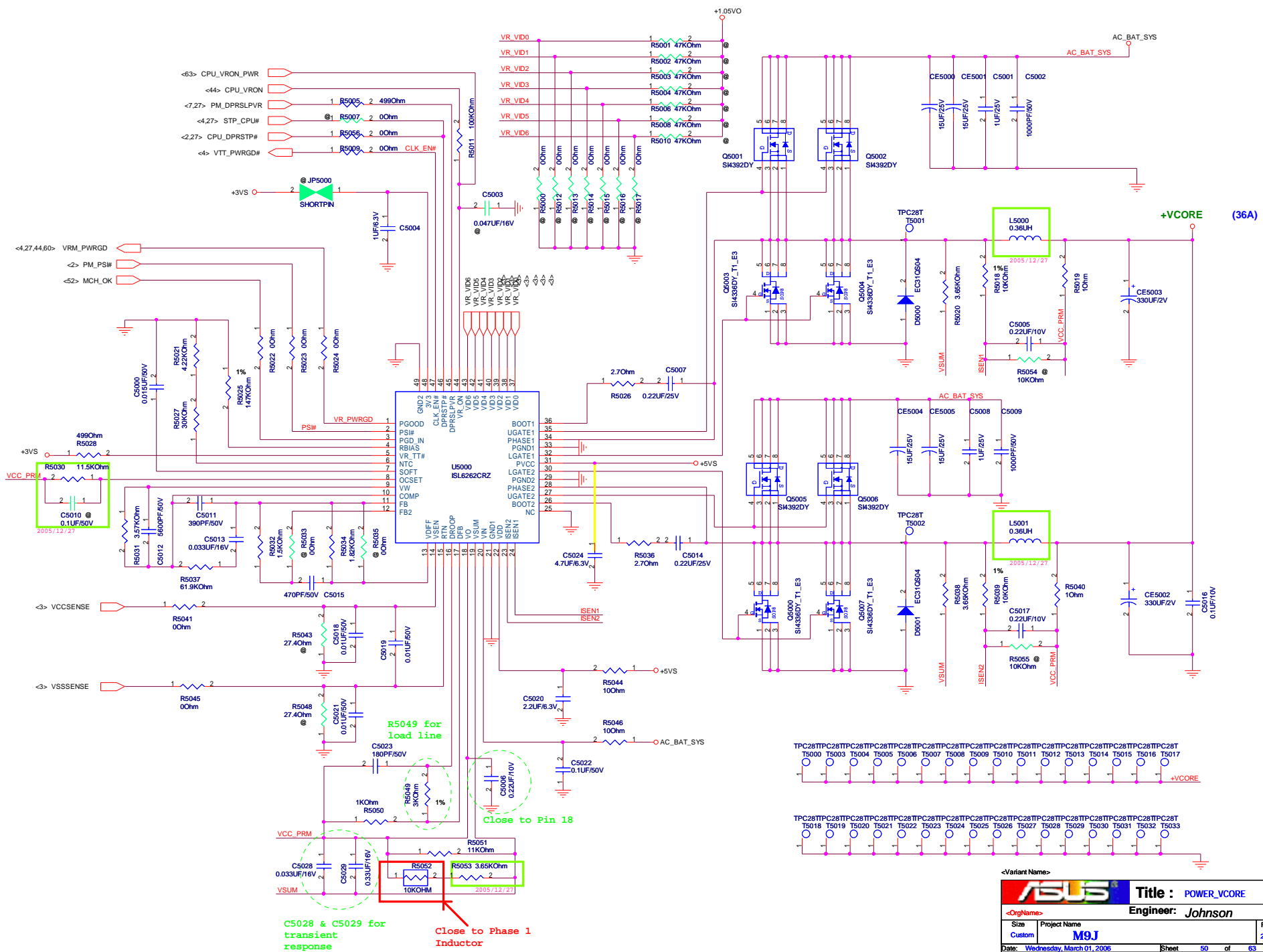

C5028 & C5029 for transient response

Close to Phase 1 Inductor

Close to Pin 18

<Variant Name>

ASUS Title : POWER_VCORE

<OrigName> Engineer: Johnson

Size	Project Name	Rev
Custom	M9J	2.0

Date: Wednesday, March 01, 2006 Sheet 50 of 63

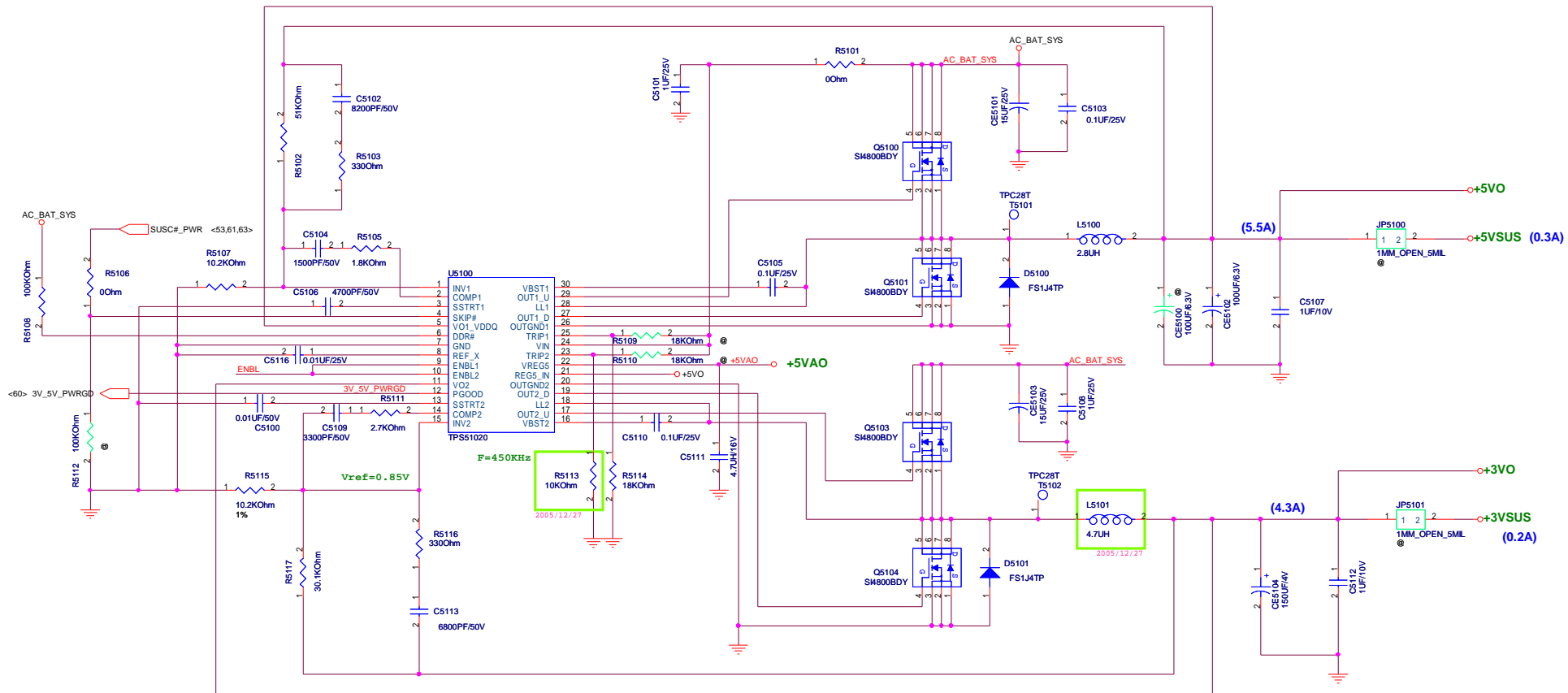

+12VSUS

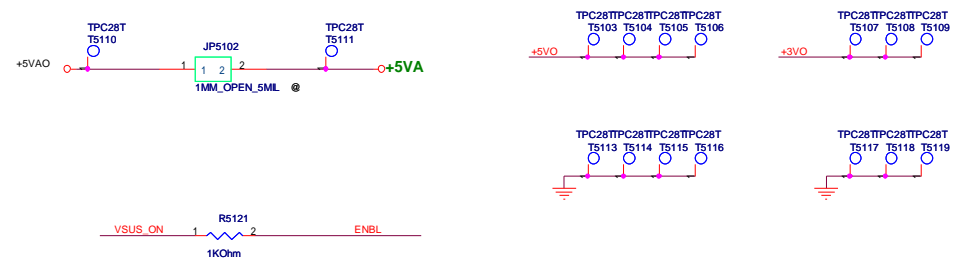
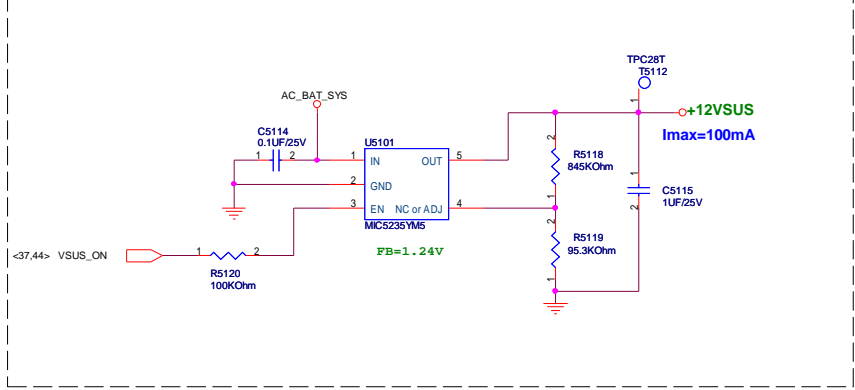

<Variant Name>

ASUS		Title : POWER_SYSTEM	
<OrgName>		Engineer: Johnson	
Size	Project Name	Date	Rev
Custom	M9J	Wednesday, March 01, 2006	2.0
Date:		Sheet	51 of 63

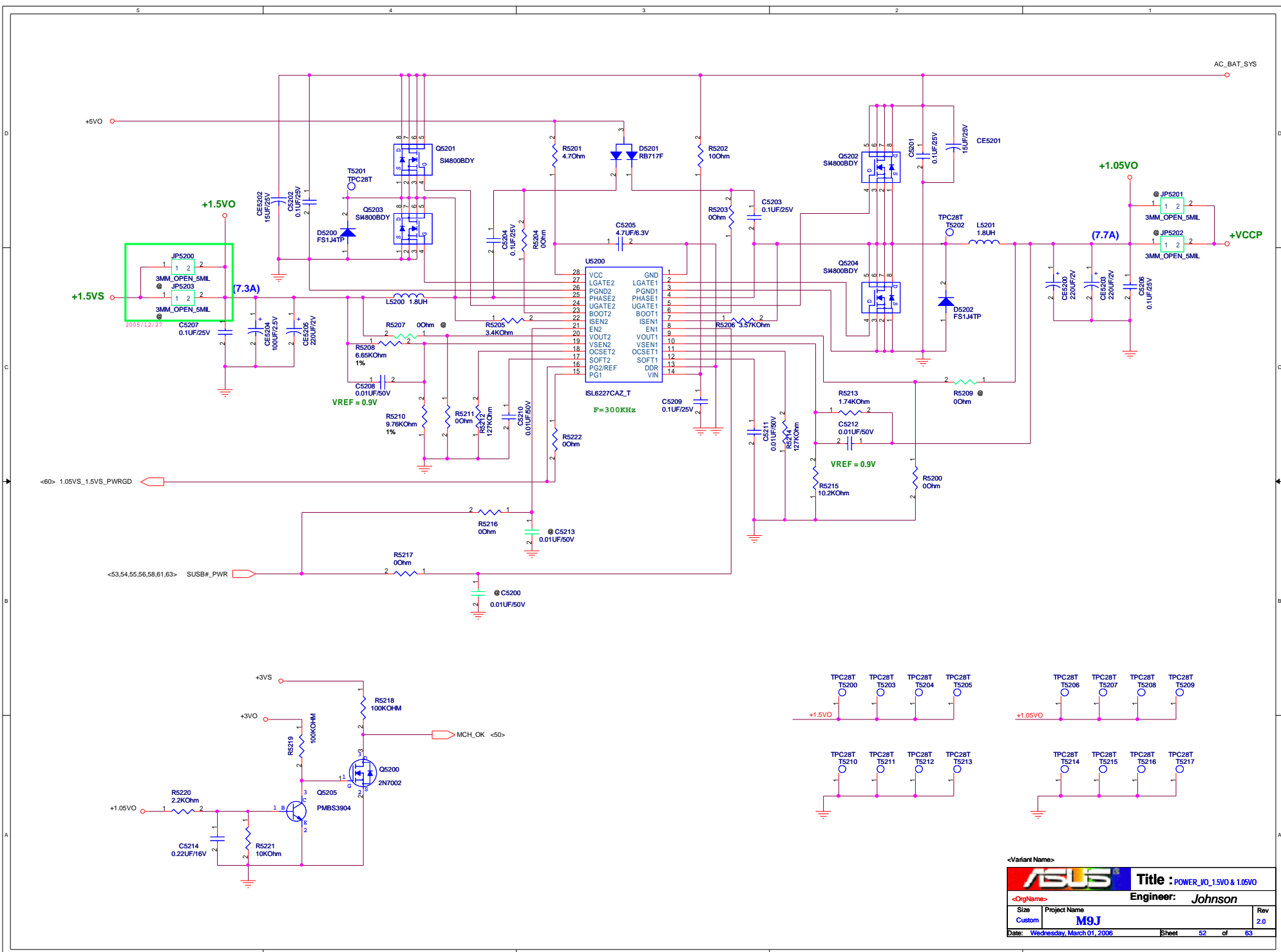

<Variant Name>

ASUS		Title : POWER_IO_1.5V0 & 1.05V0
<OrgName>		Engineer: Johnson
Size	Project Name	Rev
Custom	M9J	2.0
Date: Wednesday, March 01, 2006		Sheet 52 of 63

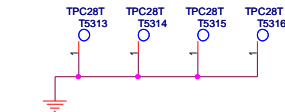
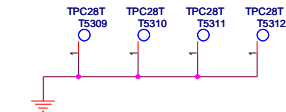
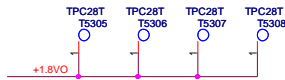
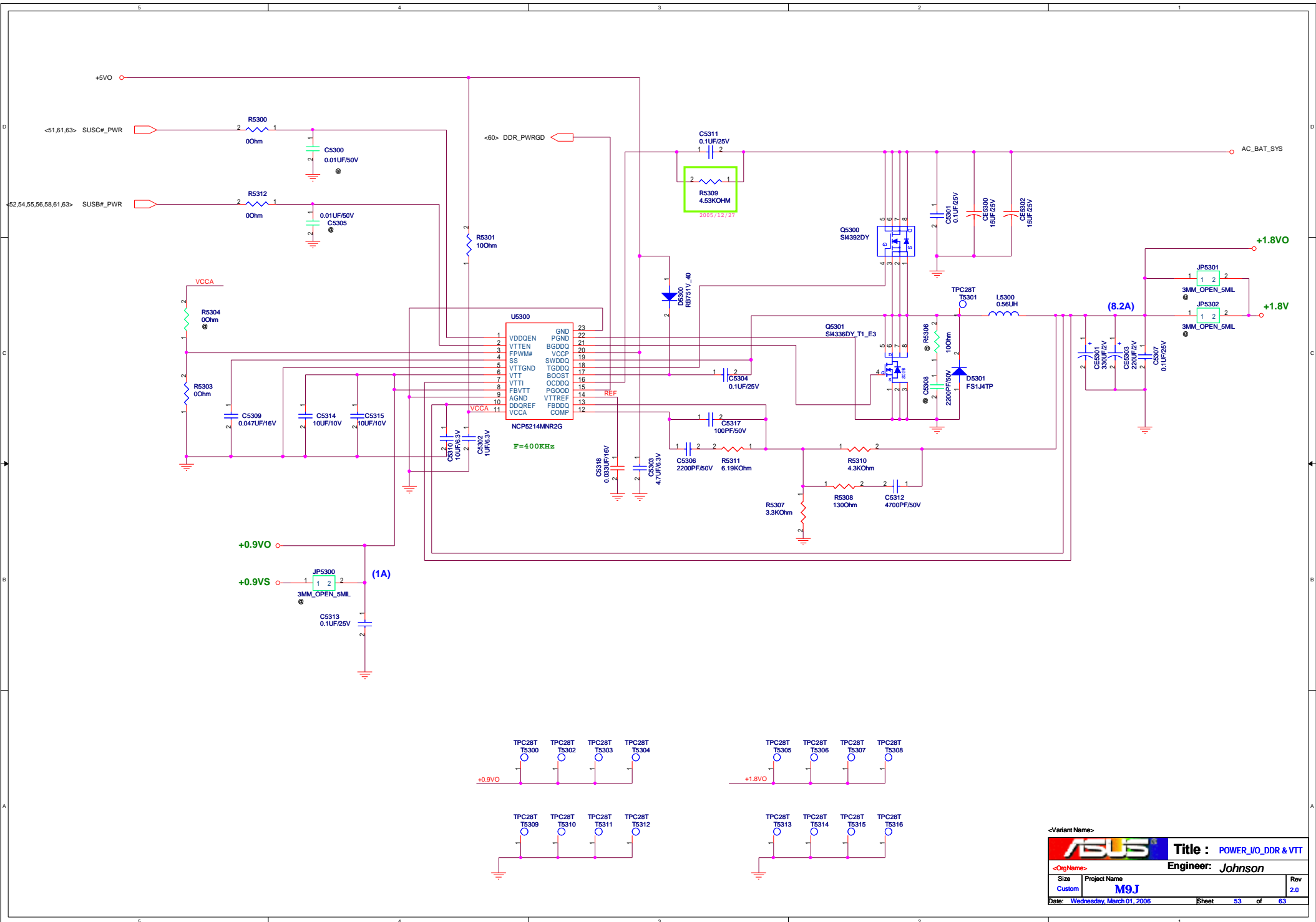

<Variant Name>

ASUS		Title : POWER_VO_DDR & VTT
<OrigName>		Engineer: Johnson
Size	Project Name	Rev
Custom	M9J	2.0
Date: Wednesday, March 01, 2006		Sheet 53 of 63

+3VAO

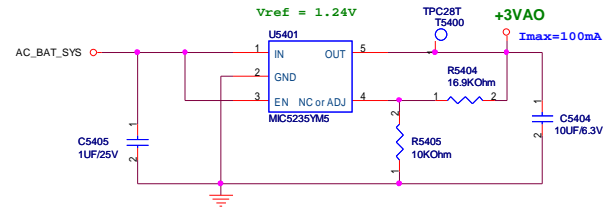
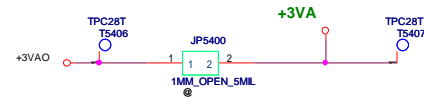

+2.5VS

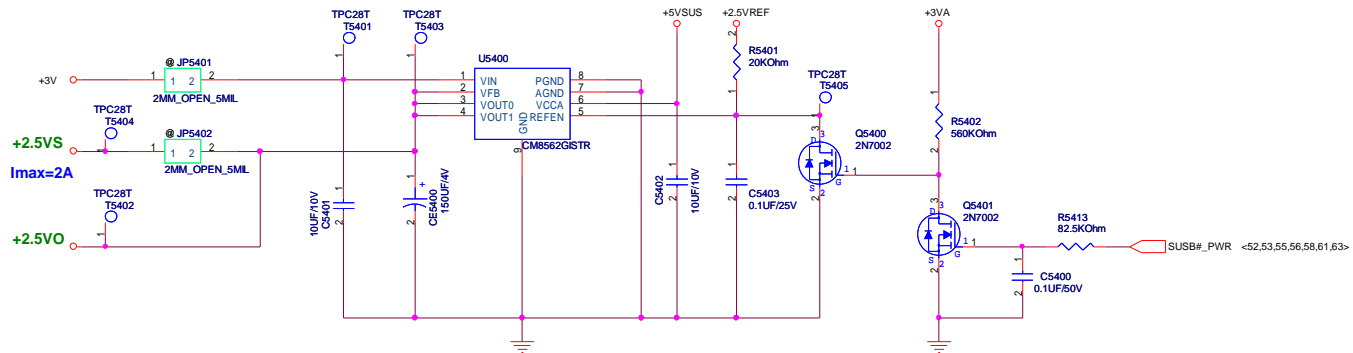

<Variant Name>

		Title : POWER_I/O_+3VA & +2.5V	
<OrigName>		Engineer: Johnson	
Size	Project Name	Rev	
Custom	M9J	2.0	
Date: Wednesday, March 01, 2006		Sheet	54 of 63

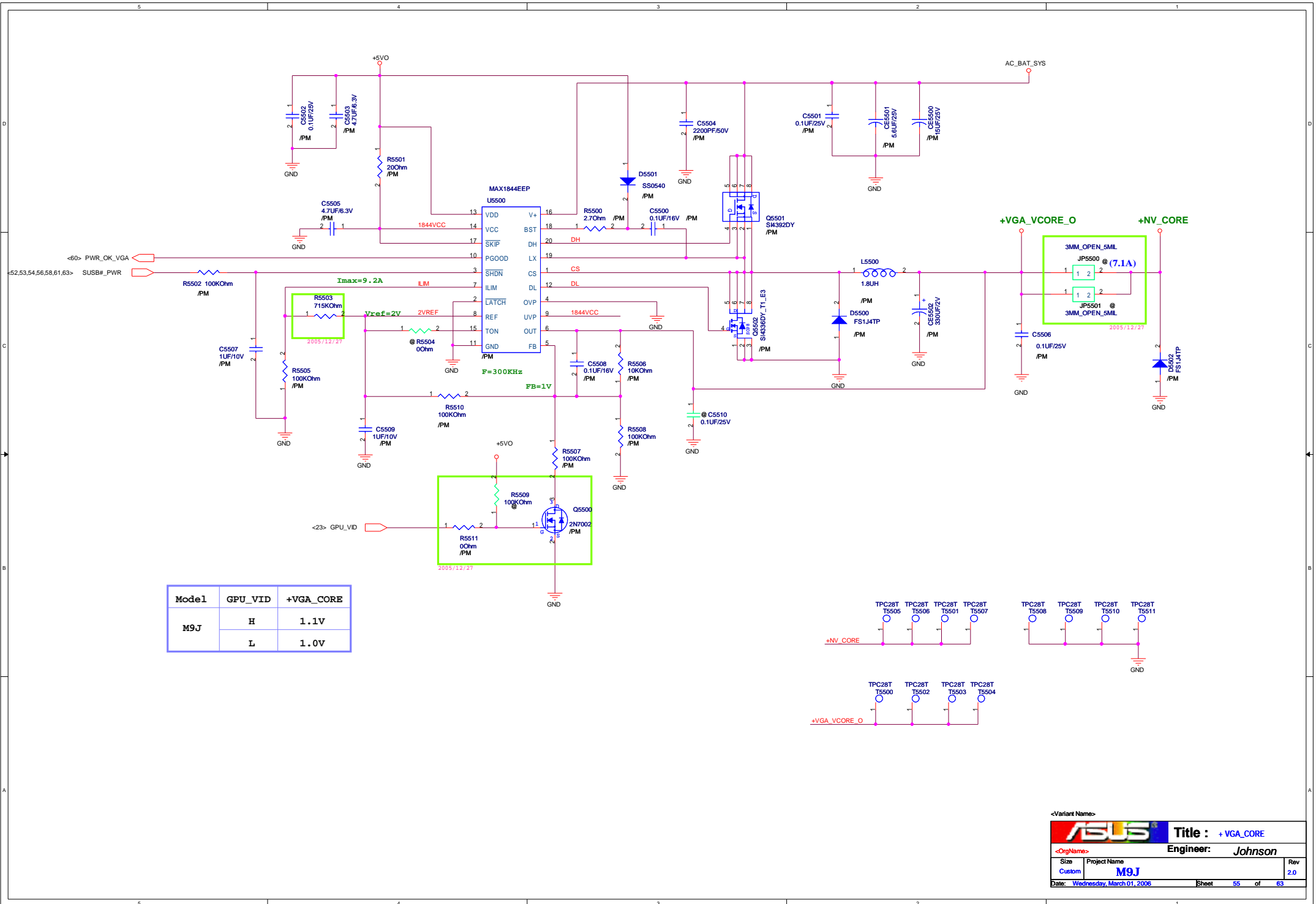

Model	GPU_VID	+VGA_CORE
M9J	H	1.1V
	L	1.0V

+1.2VSP

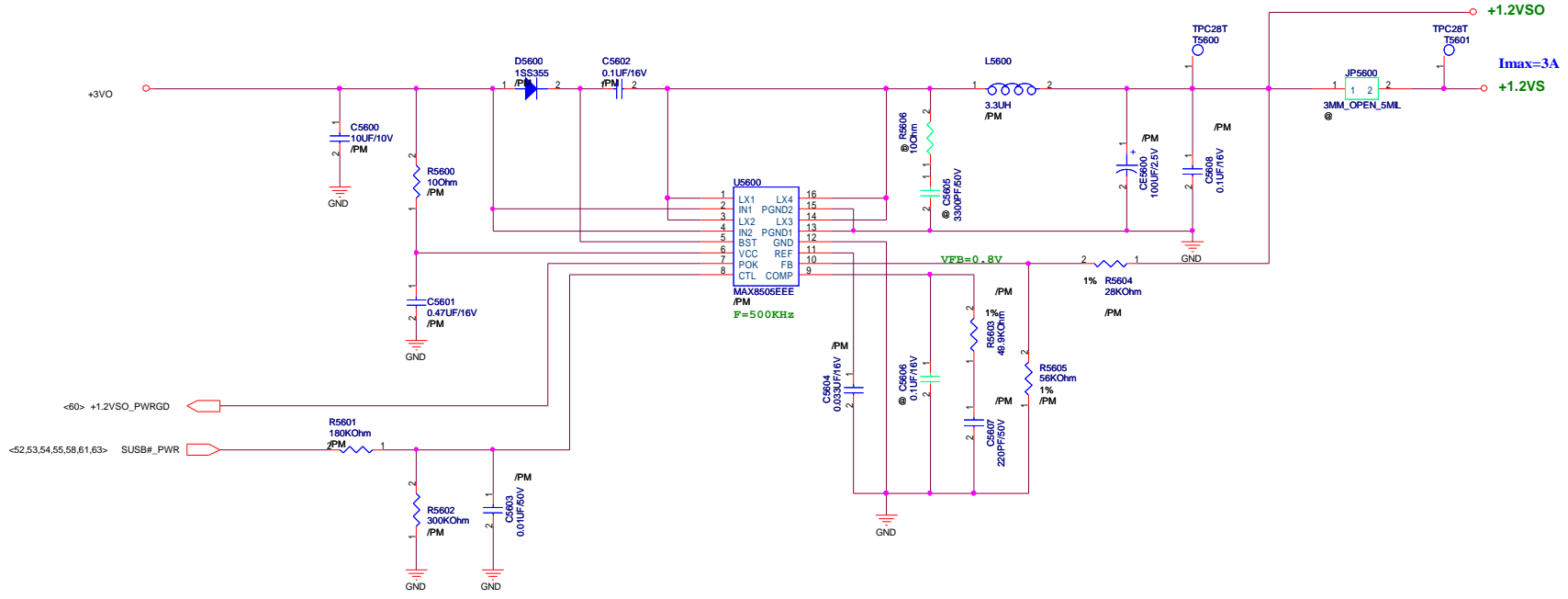

<Variant Name>

		Title : POWER_VGA_+1.2VSP	
<OrgName>		Engineer: Johnson	
Size	Project Name	Rev	
Custom	M9J	2.0	
Date: Wednesday, March 01, 2006		Sheet	56 of 63

POWER PATH & BAT_LEARN

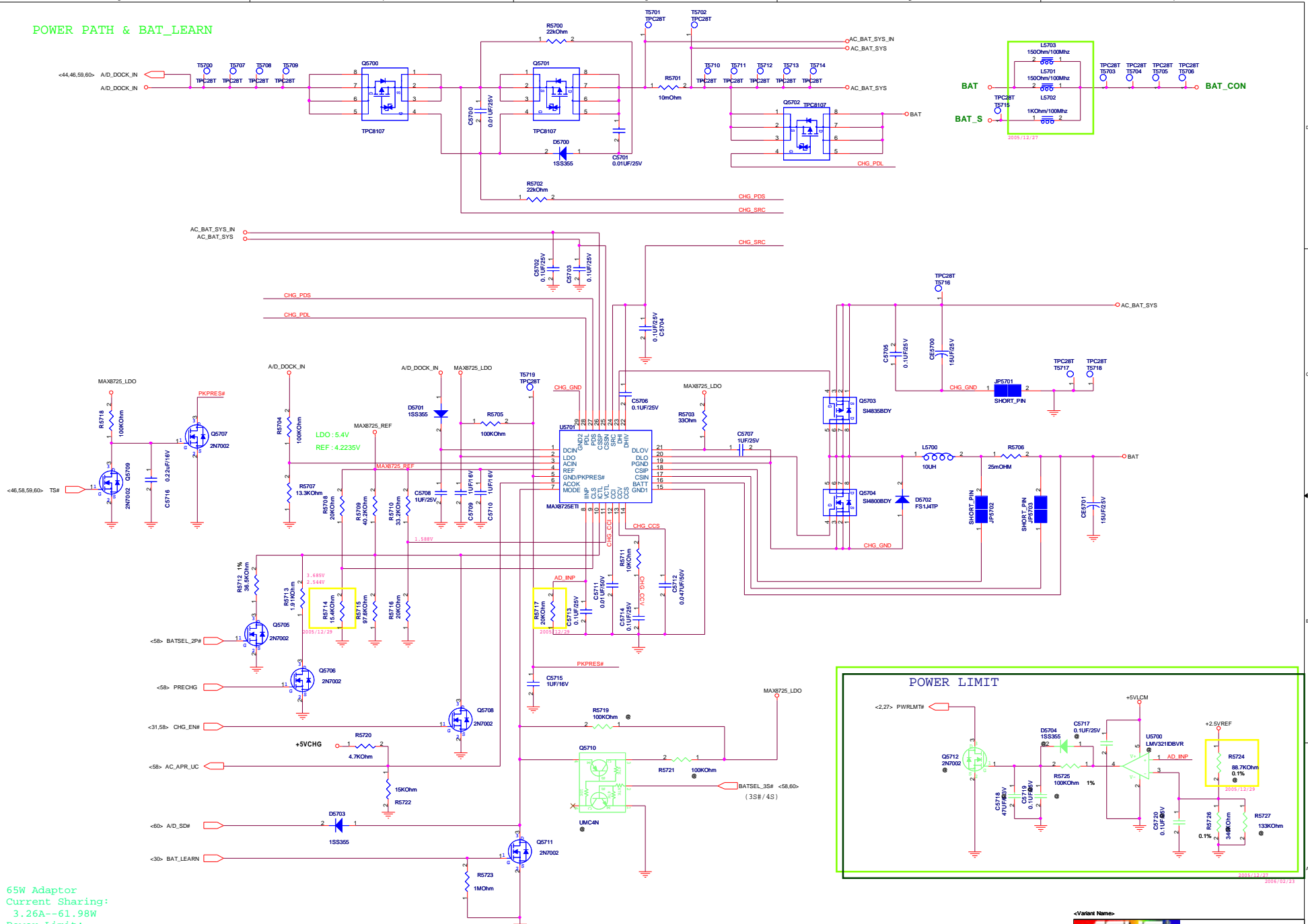

65W Adaptor
 Current Sharing:
 3.26A--61.98W
 Power Limit:
 3.305A--62.8W

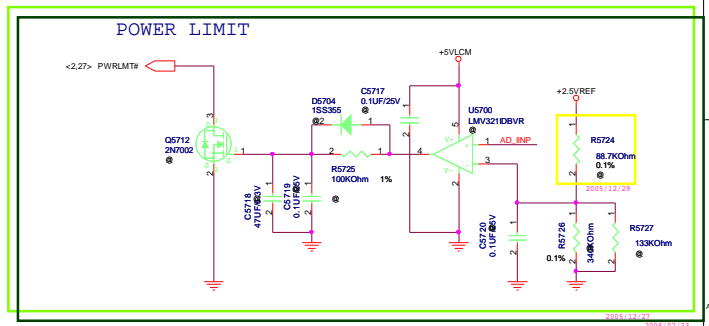
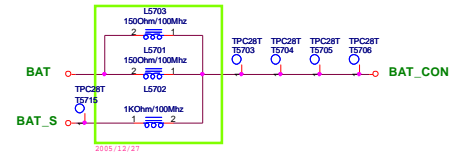

ASUS		Title : POWER_CHARGER	
Engineer: Johnson		Date: Wednesday, March 01, 2006	
Size: C	Project Name: MOJ	Rev: 2.0	Sheet: 67 of 63

BATTERY IN DETECT

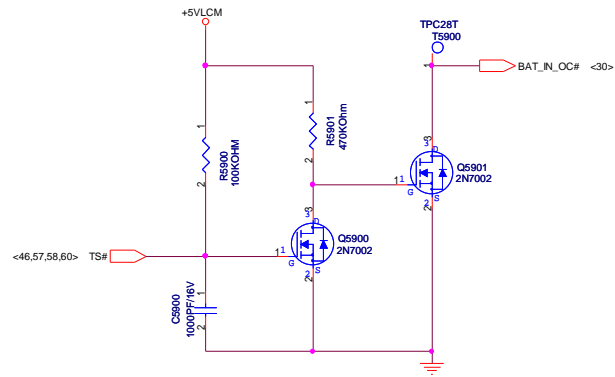

ADAPTER IN DETECT

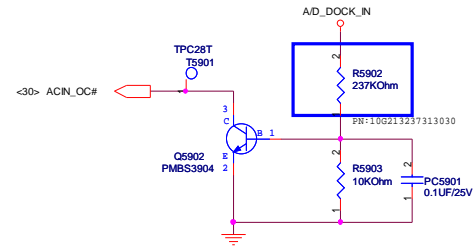

+5VLCM, +5VCHG & +2.5VREF

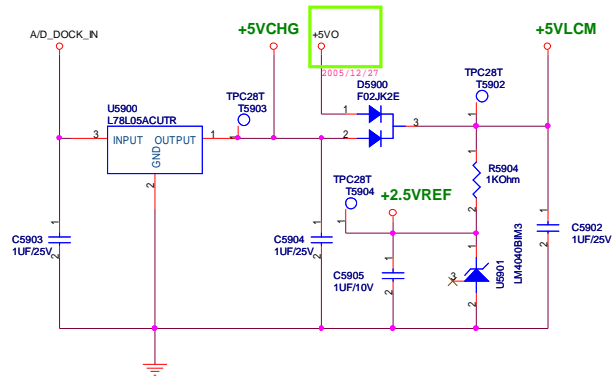

<Variant Name>

		Title : POWER_DETECT	
<OrgName>		Engineer: Johnson	
Size	Project Name	Rev	
Custom	M9J	2.0	
Date: Wednesday, March 01, 2006		Sheet	59 of 63

BATTERY A/D_SD# (OVP)

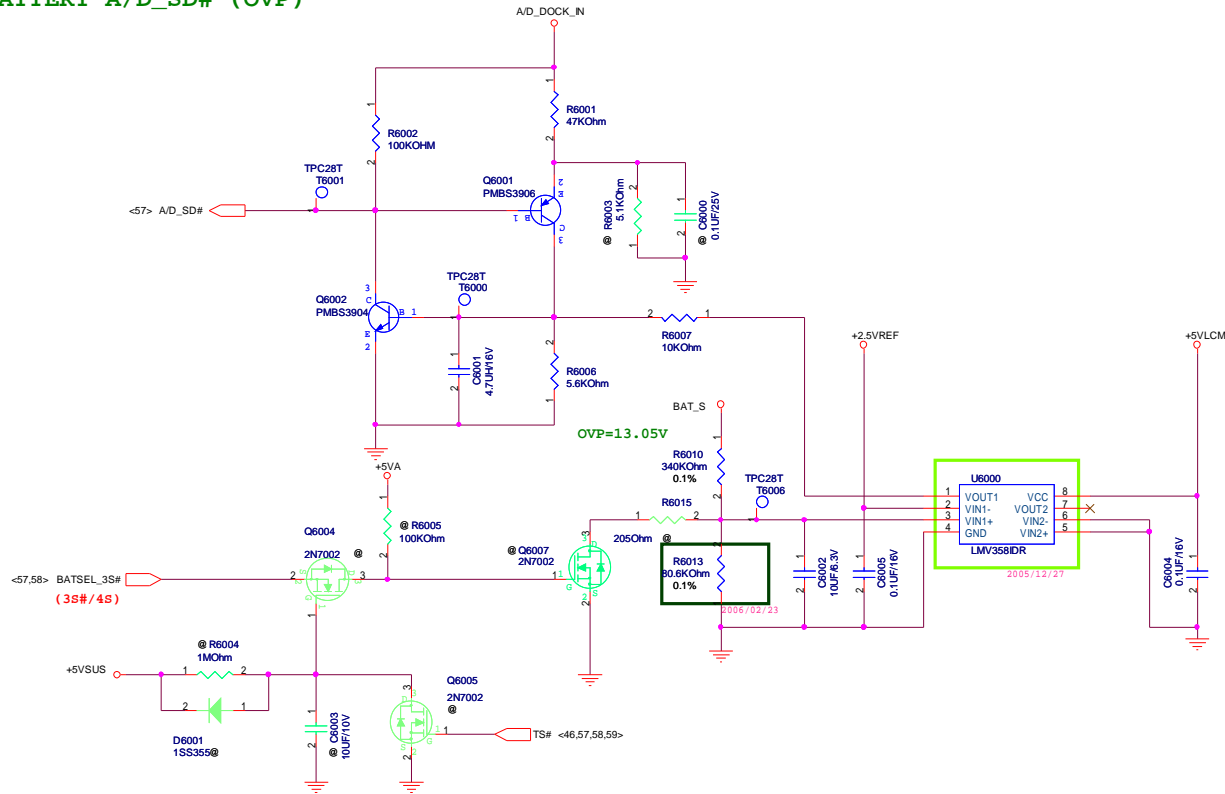

POWER GOOD DETECTOR

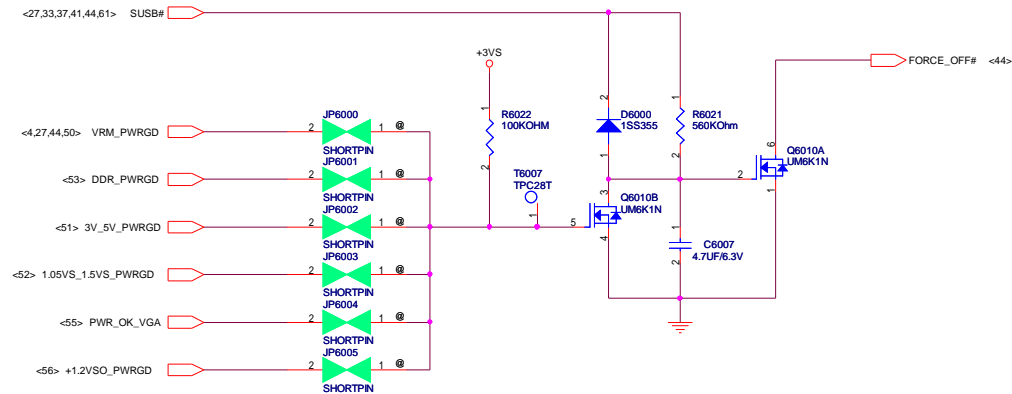

- TPC28T T6002 1 VRM_PWRGD
- TPC28T T6003 1 DDR_PWRGD
- TPC28T T6004 1 3V_5V_PWRGD
- TPC28T T6005 1 1.05VS_1.5VS_PWRGD

<Variant Name>

ASUS		Title : POWER_PROTECT	
<OrgName>		Engineer: Johnson	
Size	Project Name	Rev	
Custom	M9J	2.0	
Date: Wednesday, March 01, 2006		Sheet	60 of 63

SUSB#_PWR POWER

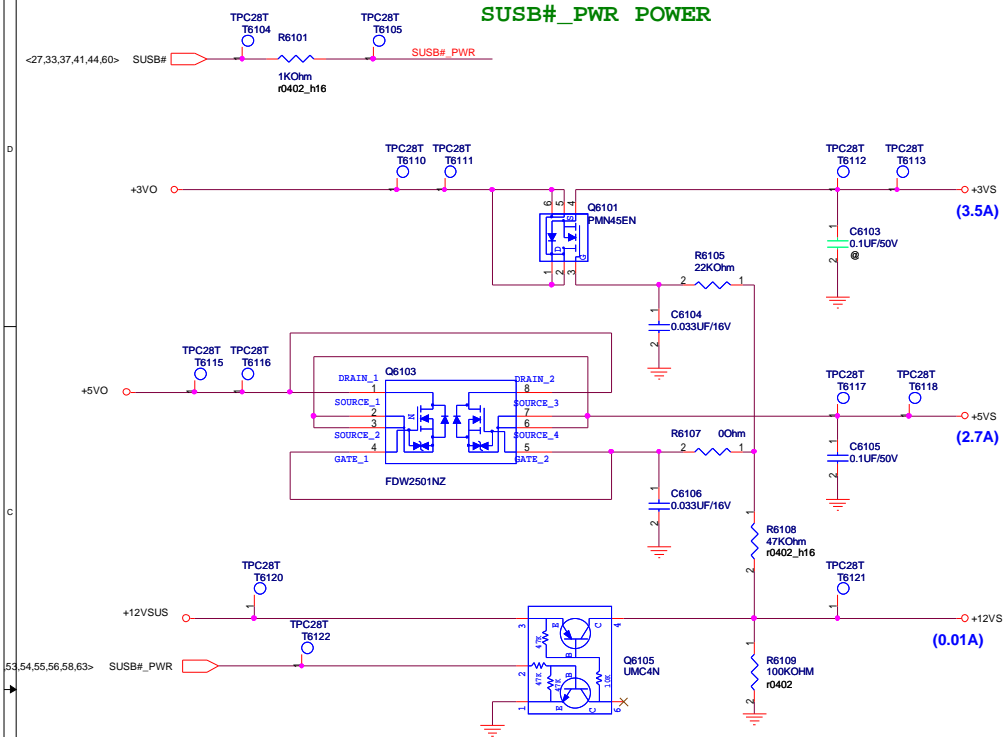

SUSC#_PWR POWER

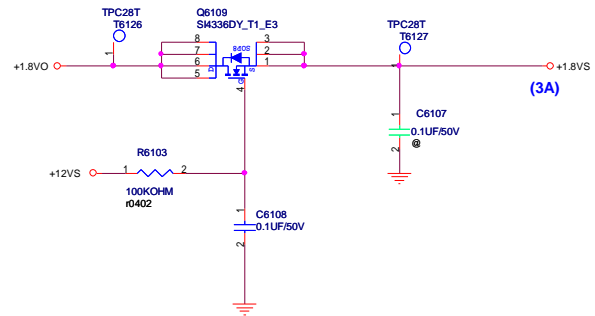
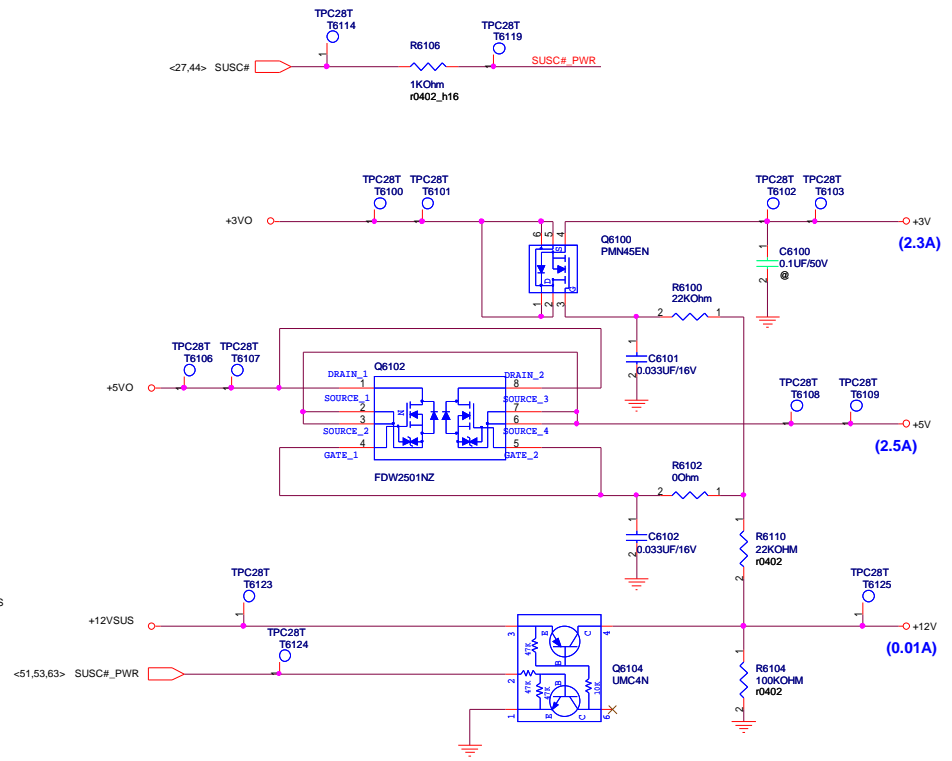

<Variant Name>

ASUS		Title : POWER_LOAD SWITCH	
<OrgName>		Engineer: Johnson	
Size Custom	Project Name M9J	Rev 2.0	
Date: Wednesday, March 01, 2006	Sheet	61	of 63

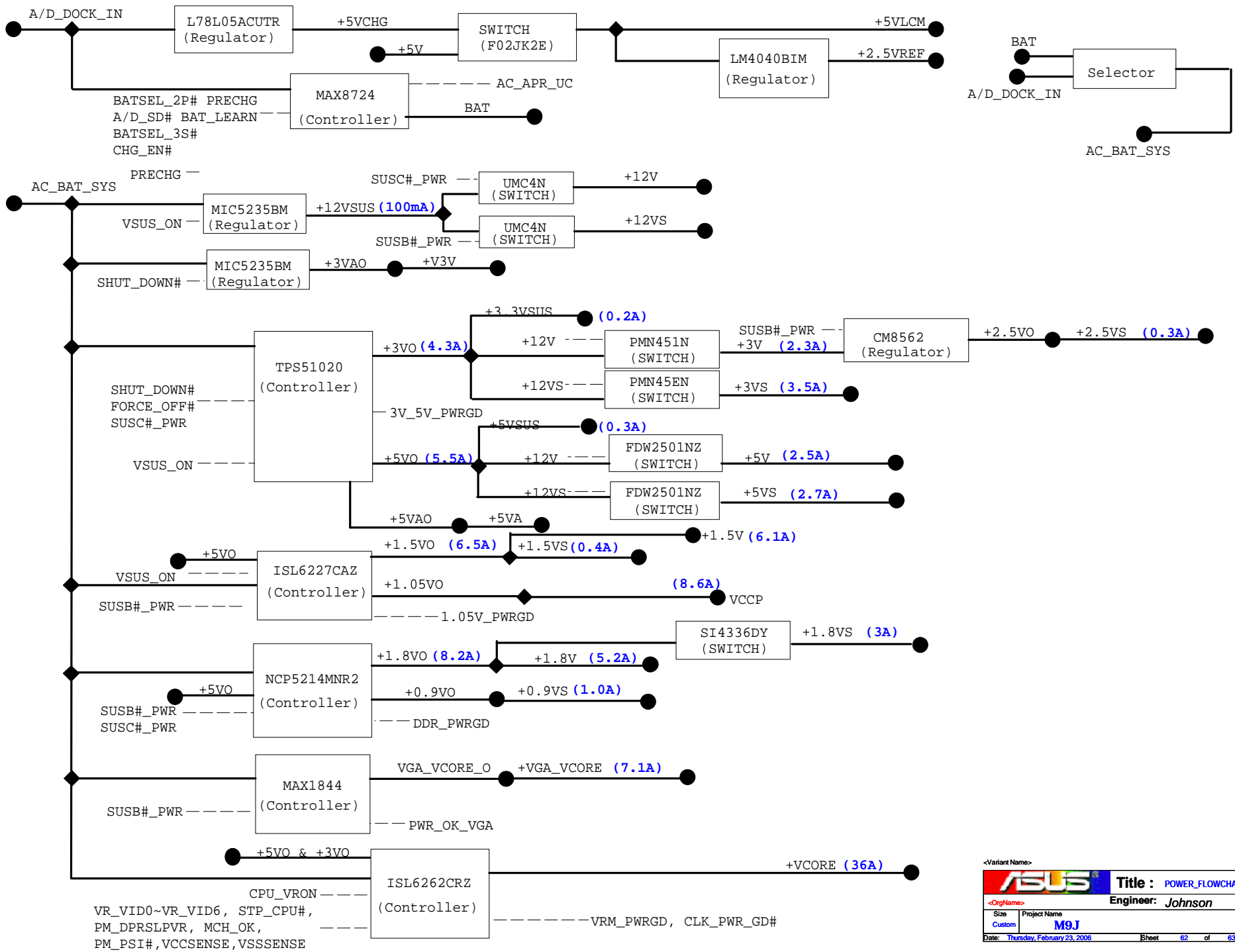

<Variant Name>

		Title : POWER_FLOWCHART	
<OrgName>		Engineer: Johnson	
Size	Project Name	Rev	
Custom	M9J	2.0	
Date: Thursday, February 23, 2006		Sheet	62 of 63

FOR POWER TEST

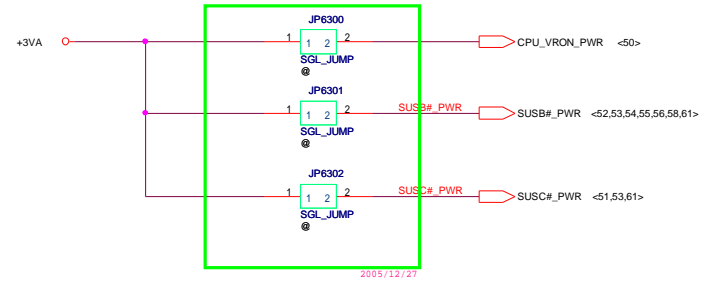
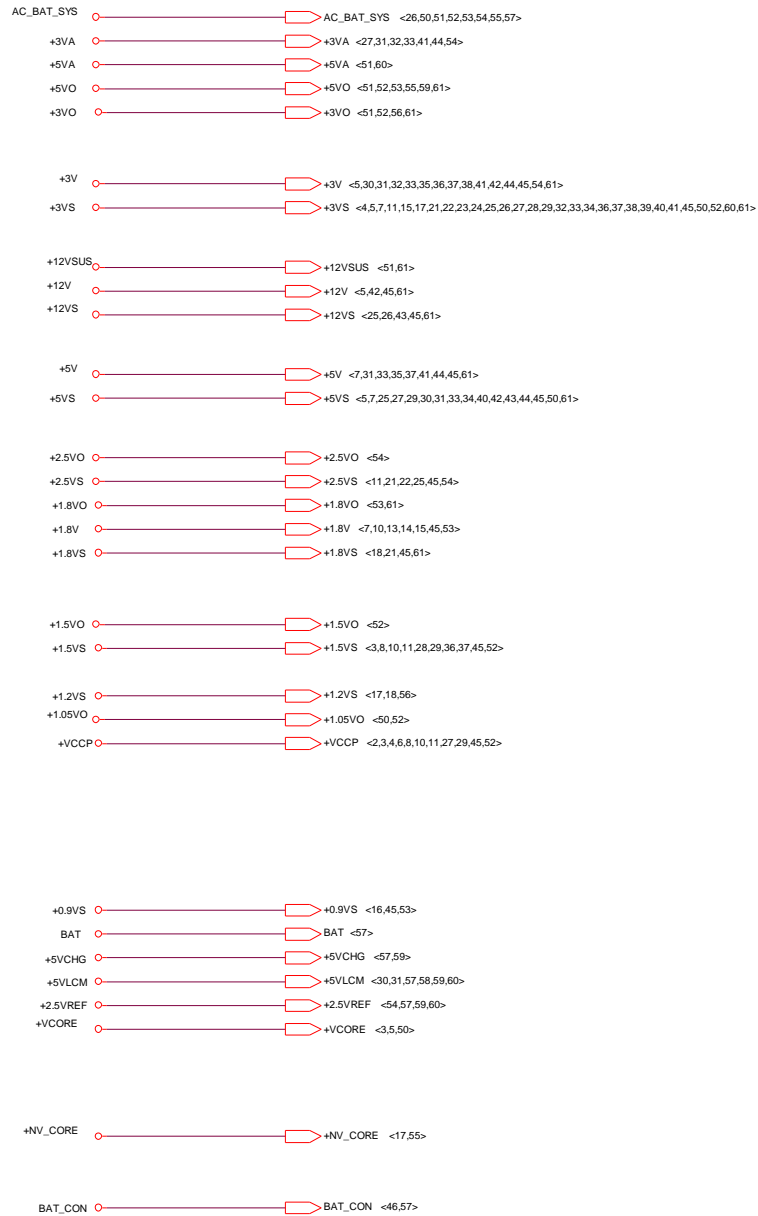

MODIFY LIST

- 2000/02/23
- 1.Unmount Power Limit Circuit
 - 2.Modify OVP Circuit
 - 3.Change R6013 to 0.1k resistor

<Variant Name>

ASUS		Title : POWER_SIGNAL	
<OrgName>		Engineer: Johnson	
Size	Project Name	Rev	
Custom	M9J	2.0	
Date: Wednesday, March 01, 2006		Sheet	63 of 63