

- 01_Block Diagram
- 02_System Setting
- 03_Power Sequence
- 04_EC Pin Define
- 05_History
- 06_
- 07_Clock Gen_CY28442-2
- 08_Dothan_HOST
- 09_Dothan_PWR_GND
- 10_910GML_HOST_DMI
- 11_910GML_DRAM
- 12_910GML_VGA_LVDS_TV
- 13_910GML_PWR
- 14_910GML_GND
- 15_ICH6-M_Azalia_GPIO_PCI_LAN
- 16_ICH6-M_USB_PCIE_DMI_IDE_SATA
- 17_ICH6-M_PWR_GND
- 18_Onboard DRAM_1
- 19_Onboard DRAM_2
- 20_DDR2_Termination
- 21_Onboard VGA
- 22_LCD Conn
- 23_Minicard
- 24_LAN_Attansic L2
- 25_MDC_RJ11_RJ45
- 26_Flash Conn
- 27_USB Port
- 28_Card Reader_ENE UB6225P
- 29_Camera Conn
- 30_Codec_ALC662
- 31_Audio_AMP_Jack
- 32_EC_ENE KB3310
- 33_Switch_SPI ROM_Debug Conn
- 34_KB_Touch Pad
- 35_Thermal Sensor
- 36_LED
- 37_Discharge
- 38_PWR Jack
- 39_Srew Hole
- 40_EMI
- 41_POWER FLOW
- 42_CHARGER
- 43_VCORE(7A)
- 44_POWER_3V_5V_VTT_DDR
- 45_POWER_3VA_3VSB
- 46_POWER_1.05V_1.5V_2.5V
- 47_POWER_1.8V_DUAL_5VSB

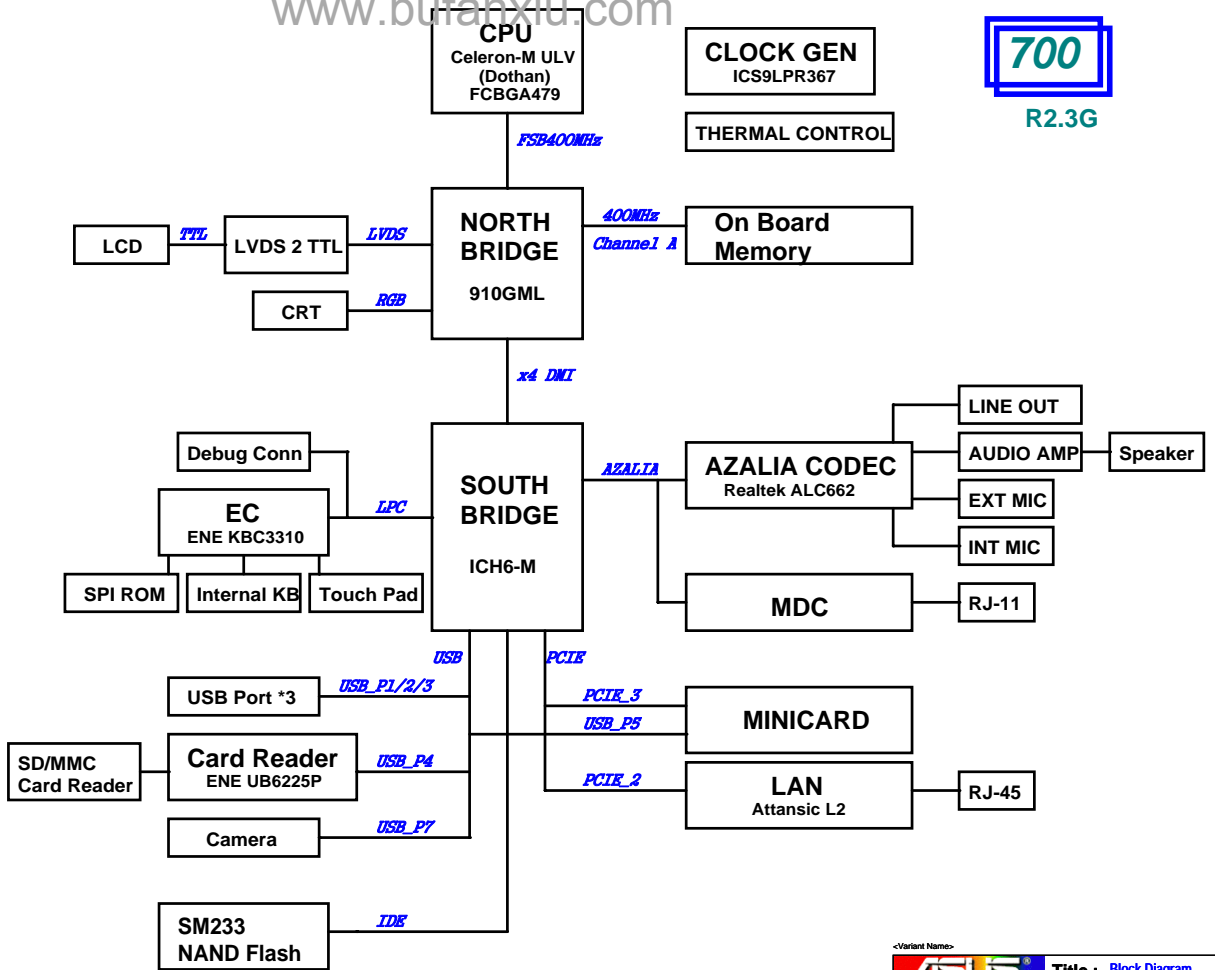

<Variant Name>

| | | | |
|-----------------------|--------------|------------------------------|-------|
| ASUS | | Title : Block Diagram | |
| ASUSTek Computer INC. | | Engineer: <i>Kell_Huang</i> | |
| Size | Project Name | Rev | |
| A3 | P700 | | R2.3G |
| Date: 08-11-13-2007 | Sheet | 1 | of 48 |

ICH6 GPIO SETTING

| Pin | Pin Name | Connect to | Type | Input/Output Set |
|------|-------------------|-------------------|------|----------------------|
| B7 | GPIO/REQ6# | 10K Pull +3V | I | fixed as Input only |
| E8 | GPI1 / REQ5# | 10K Pull +3V | I | fixed as Input only |
| D9 | GPI2 / PIRQE# | 10K Pull +3V | I | fixed as Input only |
| C7 | GPI3 / PIRQF# | 10K Pull +3V | I | fixed as Input only |
| C6 | GPI4 / PIRQG# | 10K Pull +3V | I | fixed as Input only |
| M3 | GPI5 / PIRQH# | 10K Pull +3V | I | fixed as Input only |
| AD19 | GPI6 / BMBUSY# | NB BMBUSY# | I | Input |
| AE19 | GPI7 | NC | GPI | fixed as Input only |
| R1 | GPI8 | EC KBC_SCI# | GPI | fixed as Input only |
| C23 | GPI9/OC4# | 10K Pull +3V | I | Input |
| D23 | GPI10/OC5# | 10K Pull +3V | I | Input |
| W6 | GPI11 / SMBALERT# | 10K Pull +3V | I | Input |
| M2 | GPI12 | NC | GPI | fixed as Input only |
| R6 | GPI13 | EC EXTSM# | GPI | fixed as Input only |
| C25 | GPI14/OC6# | 10K Pull +3V | I | Input |
| C24 | GPI15 /OC7# | 10K Pull +3V | I | Input |
| D8 | GPO16/GTN6# | NC | O | Output |
| F6 | GPO17 / GNT5# | NC | O | Output |
| AC21 | GPO18 / STP_PC# | Clock GEN STP_PC# | O | Output |
| AB21 | GPO19 | WLAN_LED# | GPO | fixed as Output only |
| AD22 | GPO20 / STP_CPU# | STP_CPU# | O | Output |
| AD20 | GPO21 | NC | GPO | fixed as Output only |
| NA | GPIO22 | NA | NA | NA |
| AD21 | GPO23 | NC | GPO | fixed as Output only |
| V3 | GPIO24 | WLAN | I/O | Output |
| P5 | GPIO25 | NC | I/O | Output |

| Pin | Pin Name | Connect to | Type | Input/Output Set |
|------|------------------|--------------|------|------------------|
| AF17 | GPI26/SATA0GP | NC | GPI | (GPI)Input |
| R3 | GPIO27 | NC | I/O | Output |
| T3 | GPIO28 | NC | I/O | Output |
| AE18 | GPI29 / SATA1GP | PCBVER0 | GPI | (GPI)Input |
| AF18 | GPI30 / SATA2GP | NC | GPI | (GPI)Input |
| AG18 | GPI31 / SATA3GP | PCBVER1 | GPI | (GPI)Input |
| AF19 | GPIO32 / CLKRUN# | 10K Pull +3V | I/O | Input |
| AF20 | GPIO33 | NC | I/O | Output |
| AC18 | GPIO34 | NC | I/O | Output |
| NA | GPIO35 | NA | NA | NA |
| NA | GPIO36 | NA | NA | NA |
| NA | GPIO37 | NA | NA | NA |
| NA | GPIO38 | NA | NA | NA |
| NA | GPIO39 | NA | NA | NA |
| F7 | GPI40 / REQ4# | 10K Pull +3V | I | Input |
| P4 | GPI41 / LDRQ1# | NC | I | Input |
| NA | GPIO42 | NA | NA | NA |
| NA | GPIO43 | NA | NA | NA |
| NA | GPIO44 | NA | NA | NA |
| NA | GPIO45 | NA | NA | NA |
| NA | GPIO46 | NA | NA | NA |
| NA | GPIO47 | NA | NA | NA |
| E7 | GPO48 / GNT4# | NC | O | Output |
| AC25 | GPO49 / CPUPWRGD | CPU Power Ok | O | Output |

<Variant Name>

| | | | |
|--|--------------|-------------------------------|-------|
|  | | Title : System Setting | |
| ASUSTek Computer INC. | | | |
| Size | | Engineer: Kell_Huang | |
| A3 | Project Name | | Rev |
| | P700 | | R2.3C |
| Date: 11/13/2007 | Sheet 2 | | of 48 |

*This sequence is for Battery Plug-in and no Adapter,
 if Adapter Plug-in, the sequence change to:
 A/D_DOCK_IN-->AC_BAT_SYS-->+3VA-->VSUS_ON-->+3VSB & +5VSB
 -->VSUS_GD-->PM_REMRST#-->PWR_SW#-->PM_PWRBTN-->PM_SUSC#-->PM_SUSB#

| | Signal | S0/S1 | S3 | S4/S5 | Power |
|--------------|---------|-------|----|-------|-------|
| Only Battery | VSUS_ON | H | H | L | VSB |
| Adapter In | VSUS_ON | H | H | H | VSB |
| | SUSB_ON | H | L | L | Main |
| | SUSC_ON | H | H | L | DUAL |

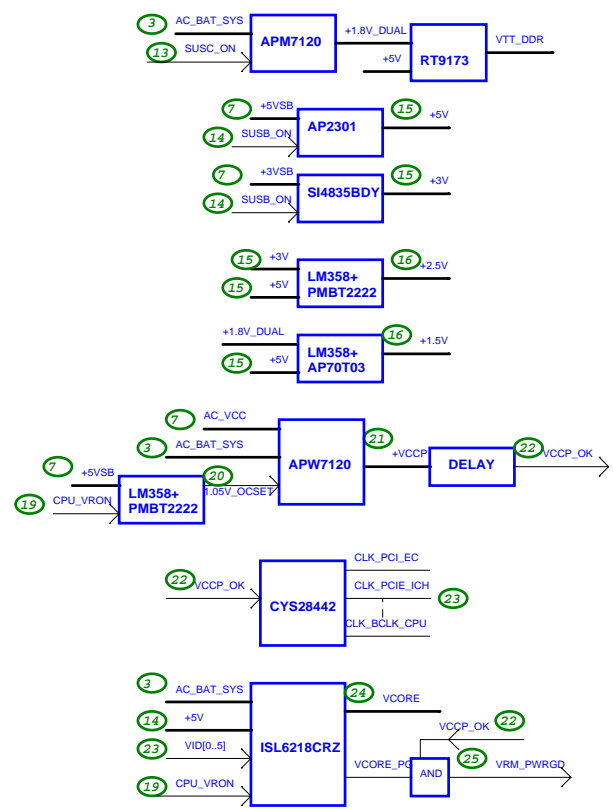
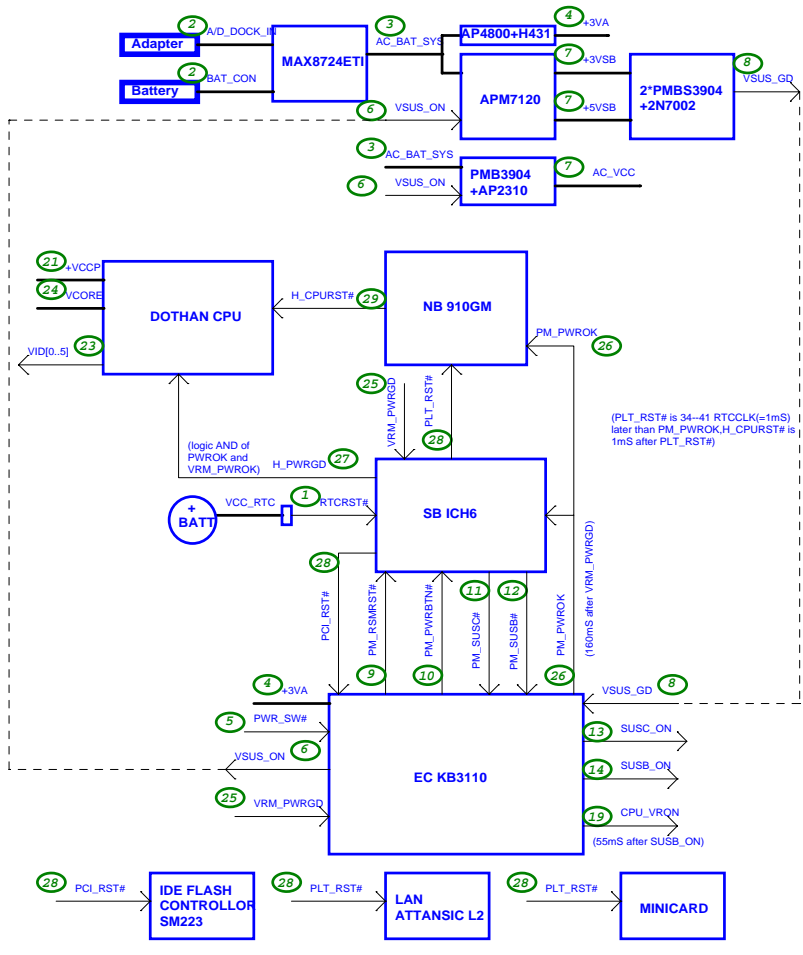

ASUS Title: Power Sequence
 Engineer: Kell Huang
 Project Name: P700
 Date: 11/13/2007
 Sheet 3 of 48

EC KB3310 GPIO SETTING

| Pin No. | Pin Name | Signal Name | Type | NOTE |
|---------|----------|------------------|------|--------------------------|
| 1 | GA20 | AZOGATE | O | AZOGATE |
| 2 | KBRST# | RC_IN# | O | KBRST# |
| 6 | GPIO04 | CTRL_CAMER_PWR | I | Default: High |
| 13 | PCIRST# | PCI_RST# | I | PCI Reset |
| 14 | GPIO07 | N.C | O | Reserved |
| 15 | GPIO08 | EXTSM# | O | EXTSM#, 10K Pull +3VSUS |
| 16 | GPIO0A | LID_EC# | I | LID_EC#, * |
| 17 | GPIO0B | LCD_CSB | O | LCD chip select |
| 18 | GPIO0C | LCD_SDA | I/O | LCD Data |
| 19 | GPIO0D | DISTP_SW# | I | Touch Pad Disabled, * |
| 20 | SCI# | KBC_SC# | O | KBC_SC#, 10K Pull +3VSUS |
| 21 | PWM1 | BL_PWM_DA | O | LCD Light Switch |
| 23 | PWM2 | LCD_SCL | O | LCD clock |
| 25 | GPIO11 | PM_PWRBTN# | OD | Power Button to SB, * |
| 26 | FANPWM1 | FAN0_PWM | O | CPU Fan(Unused) |
| 27 | FANPWM2 | FAN1_PWM | O | VGA Fan(Unused) |
| 28 | FANFB1 | FAN0_TACH | I | CPU FanTach(Unused) |
| 29 | FANFB2 | FAN1_TACH | I | VGA FanTach(Unused) |
| 30 | GPIO16 | ES1_TX | O | RS232 debug port |
| 31 | GPIO17 | N.C | O | Reserved |
| 32 | GPIO18 | PWR_SW# | I | power button, * |
| 34 | GPIO19 | MAIL_LED# | O | Mail LED(Unused) |
| 36 | GPIO1A | CTRL_MinCard_PWR | O | Default: High |
| 38 | CLKRUN# | N.C | O | Reserved |
| 39 | KSO0 | KSO0 | O | For Keyboard interface |
| 40 | KSO1 | KSO1 | O | For Keyboard interface |
| 41 | KSO2 | KSO2 | O | For Keyboard interface |
| 42 | KSO3 | KSO3 | O | For Keyboard interface |
| 43 | KSO4 | KSO4 | O | For Keyboard interface |
| 44 | KSO5 | KSO5 | O | For Keyboard interface |
| 45 | KSO6 | KSO6 | O | For Keyboard interface |
| 46 | KSO7 | KSO7 | O | For Keyboard interface |
| 47 | KSO8 | KSO8 | O | For Keyboard interface |
| 48 | KSO9 | KSO9 | O | For Keyboard interface |
| 49 | KSO10 | KSO10 | O | For Keyboard interface |
| 50 | KSO11 | KSO11 | O | For Keyboard interface |
| 51 | KSO12 | KSO12 | O | For Keyboard interface |
| 52 | KSO13 | KSO13 | O | For Keyboard interface |
| 53 | KSO14 | KSO14 | O | For Keyboard interface |
| 54 | KSO15 | KSO15 | O | For Keyboard interface |
| 55 | KSI0 | KSI0 | I | For Keyboard interface |
| 56 | KSI1 | KSI1 | I | For Keyboard interface |
| 57 | KSI2 | KSI2 | I | For Keyboard interface |
| 58 | KSI3 | KSI3 | I | For Keyboard interface |
| 59 | KSI4 | KSI4 | I | For Keyboard interface |
| 60 | KSI5 | KSI5 | I | For Keyboard interface |
| 61 | KSI6 | KSI6 | I | For Keyboard interface |
| 62 | KSI7 | KSI7 | I | For Keyboard interface |
| 63 | AD0 | P_PMON_10 | I | Sense Power Loading |
| 64 | AD1 | BAT_IN | I | sense Battery |
| 65 | AD2 | N.C | I | Reserved |
| 66 | AD3 | N.C | I | Reserved |
| 68 | GPO3C | DOC | O | Trigger Clock Gen |

www.bufoaxiu.com

| Pin No. | Pin Name | Signal Name | Type | NOTE |
|---------|----------|--------------|------|--|
| 70 | GPO3D | LCD_BACKOFF# | O | LCD_BACKOFF# |
| 71 | GPO3E | CLK_PWRSAVE# | O | Active when BAT_#N#1 and AC_#N#(Unused) |
| 72 | GPO3F | BAT_LL# | O | Battery Low Low |
| 73 | GPIO40 | AC_OK | I | AC Adaptor Plug in |
| 74 | GPIO41 | PM_RSMRST# | O | 10K Pull GND |
| 75 | GPIO42 | N.C | O | Reserved |
| 76 | GPIO43 | N.C | O | Reserved |
| 77 | SCL1 | SMB0_CLK | I/OD | 4.7K Pull +3VA_EC |
| 78 | SDA1 | SMB0_DAT | I/OD | 4.7K Pull +3VA_EC |
| 79 | SCL2 | SMB1_CLK | I/OD | 10K Pull +3VS |
| 80 | SDA2 | SMB1_DAT | I/OD | 10K Pull +3VS |
| 81 | KSO16 | N.C | O | Reserved |
| 82 | KSO17 | N.C | O | Reserved |
| 83 | PSCLK1 | N.C | O | Reserved |
| 84 | PSDAT1 | N.C | O | Reserved |
| 85 | PSCLK2 | N.C | O | Reserved |
| 86 | PSDAT2 | N.C | O | Reserved |
| 87 | PSCLK3 | TP_CLK | I/OD | 10K Pull +3VS |
| 88 | PSDAT3 | TP_DAT | I/OD | 10K Pull +3VS |
| 89 | GPIO50 | BATSEL_3S | O | Battery select, #E3S, Led#(Unused) |
| 90 | GPIO52 | CHG_LED_UP# | O | charger LED |
| 91 | GPIO53 | CTRL_L2_PWR | O | Default: High |
| 92 | GPIO54 | PWR_LED_UP | O | EC H/W blinking |
| 93 | GPIO55 | SCRL_LED# | O | EC H/W controls |
| 95 | GPIO56 | PWR4G_SW# | I | * |
| 97 | GPX0A00 | SPI_MODE# | O | H/W Strap for SPI Flash de-Program! |
| 98 | GPX0A01 | SUSC_ON | O | Pull Down 100K ohm to GND* |
| 99 | GPX0A02 | VSUS_ON | O | |
| 100 | GPX0A03 | CPU_VRON | O | |
| 101 | GPX0A04 | SUSB_ON | O | |
| 102 | GPX0A05 | ICH8_PWROK | O | |
| 103 | GPX0A06 | N.C | O | Reserved |
| 104 | GPX0A07 | CHG_EN# | O | Battery charging enabled |
| 105 | GPX0A08 | PRECHG | O | |
| 106 | GPX0A09 | SPI_WP# | O | |
| 107 | GPX0A10 | OP_SD# | O | Audio OP |
| 108 | GPX0A11 | BAT_LEARN | O | |
| 109 | GPXID0 | BATSEL_2P# | O | Battery parallel, #E1P, Led#_2P |
| 110 | GPXID1 | N.C | O | Reserved |
| 112 | GPXID2 | THRO_CPU | O | Active if Battery Temperature is Pull Down 100K ohm to GND |
| 114 | GPXID3 | SUSB# | I | Pull Down 100K ohm to GND |
| 115 | GPXID4 | SUSC# | I | Pull Down 100K ohm to GND |
| 116 | GPXID5 | CPUPWR_GD | I | 10K Pull +3VS |
| 117 | GPXID6 | VSUS_GD | I | Disabled ** |
| 118 | GPXID7 | N.C | O | Reserved |
| 121 | GPIO57 | INTERNET# | I | * |
| 126 | SPICLK | SPI_CLK | O | SPI Clock |
| 127 | GPIO59 | N.C | O | Reserved |

EC KB3310 Other Pin SETTING

| Pin No. | Pin Name | Signal Name | Type | NOTE |
|---------|----------|-------------|------|---------------------|
| 3 | SERIRQ | INT_SERIRQ | I/OD | 8.2K Pull +3VS |
| 4 | LFAME# | LPC_FRAME# | I | |
| 5 | LAD3 | LPC_AD3 | I/O | |
| 7 | LAD2 | LPC_AD2 | I/O | |
| 8 | LAD1 | LPC_AD1 | I/O | |
| 9 | VCC | +3VA_EC | P | |
| 10 | LAD0 | LPC_AD0 | I/O | |
| 11 | GND | GND | P | |
| 12 | PCICLK | CLK_PCI_EC | I | |
| 22 | VCC | +3VA_EC | P | |
| 24 | GND | GND | P | |
| 33 | VCC | +3VA_EC | P | |
| 35 | GND | GND | P | |
| 37 | ECRST# | EC_RST# | I | Add 100K ohm to GND |
| 67 | AVCC | +3VACC | P | |
| 69 | AGND | AGND | P | |
| 94 | GND | GND | P | |
| 96 | VCC | +3VA_EC | P | |
| 111 | VCC | +3VA_EC | P | |
| 113 | GND | GND | P | |
| 119 | RD# | SPI_SO | I | |
| 120 | WR# | SPI_SI | O | |
| 112 | XCLKI | 32KXCLKI | I | |
| 123 | XCLKO | 32KXCLKO | O | |
| 124 | V18R | K_V18R | | Reserved 1uF to GND |
| 125 | VCC | +3VA_EC | P | |
| 128 | SPICS# | SPI_CE# | O | |

<Variant Name>



Title : EC Pin Define
Engineer: Keli_Huang

ASUSTek Computer INC.
 Size: A3 Project Name: P700 Rev: R2.3C
 Date: 11/13/2007 Sheet: 4 of 48

CIRCUIT UPDATED HISTORY

| Rev | Date | Description |
|------|------------|--|
| 1.0G | 2007/02/26 | S701L Schematic 1.0G Beginning |
| | 2007/03/16 | S701L 1.0G Gerber Out |
| 1.1G | 2007/03/24 | S701L Schematic 1.1G Beginning |
| | 2007/04/19 | S701L 1.1G Gerber Out |
| 1.2G | 2007/04/24 | P701(S701L renamed) Schematic 1.0G Beginning 1. PC8054, PR6075 /X to N/A 2. Attansic L2 change to Atheros L2(pin to pin) 3. LC1, LC33 /CAP/X to N/A 4. C87 change to X5R to cost down 5. L1, L2, L3 change to 56 NH, R5, R6 change to 75 Ohm to pass CRT EA measure 6. PR48 change to 22K Ohm, PC35 change to 4700PF to fix no VCORE issue 7. PR6074 change to 4.7K Ohm to fix +3VSB OCP issue 8. Clock Gen CY28442-2 change to ICS9LPR367 9. Phase in Power Level Reduce solution, mark "Taipei0508" 10. Card Reader Socket change to SD Socket 12G25100091E 11. Add System FAN circuit 12. Camera change to USB port 7, Minicard change to USB port 5 13. Use SB GPIO27 to Enable/Disable Card Reader UB6225P 14. Use SB GPIO28 to Enable/Disable Modem 15. Stuff CC33, CC34, CC35, CC36, CC37, CC38 for EMI 16. Card Reader UB6225P share 48M clock from CLock Gen with SB USB part 17. Add D29 to fix LCD_CSB leakage current issue 18. LC29, LC30 change to 27PF to pass EA crystal measure 19. Change vaule of PR73, PR74, PC56 and add PC60 to adjust the power sequence timing between Stand By power and RSMRST# 20. Remove USB port 1 21. Add +5V generate +3V_LCD circuit 22. Remove +5V_CHG generate circuit 23. Use SB GPIO33, GPIO34 to controll the level of VCORE 24. U31 use APL5315BI-TRL to replace MAX8863TEUK(pin to pin, but reference voltage level different) 25. PR59 change to 130K Ohm for both 12V Adapter and 9.8V Adapter |

| Rev | Date | Description |
|-----|------|-------------|
| | | |

<Variant Name>

| | | | |
|---|----------------------|-----------------------------|--|
|  | | Title : History | |
| ASUSTek Computer INC. | | Engineer: Kell_Huang | |
| Size A3 | Project Name P700 | Rev R2.3G | |
| Date: 04/13/2007 | Sheet 5 | of 48 | |

<Variant Name>

| | | |
|---|--------------|-----------------------------|
|  | | Title : Blank |
| ASUSTek Computer INC. | | Engineer: Keli_Huang |
| Size | Project Name | Rev |
| A3 | P700 | R2.3G |
| Date: | 2007.11.13 | Sheet 6 of 48 |

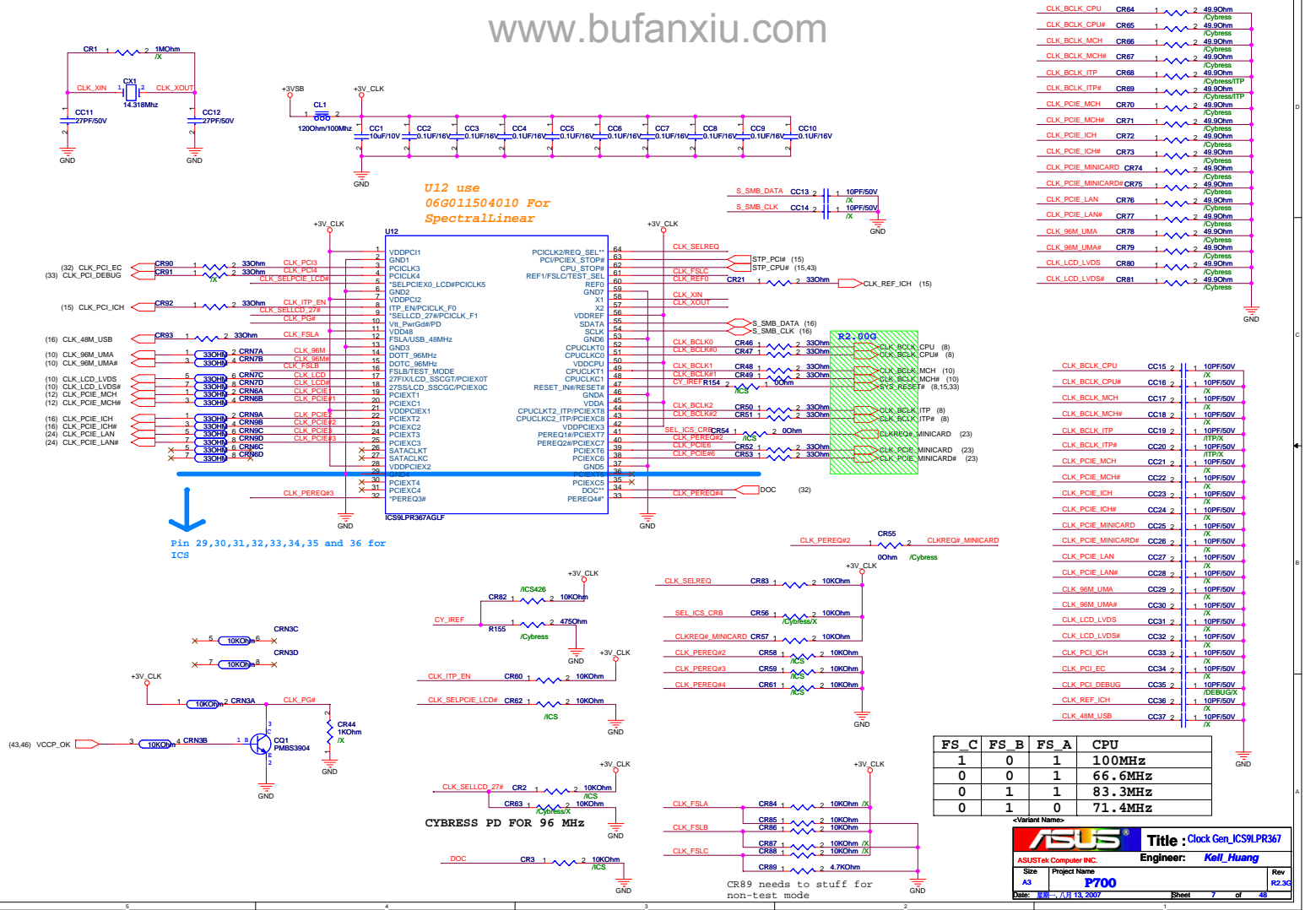

| | | | |
|--------------------|------|---|----------|
| CLK_BCLK_CPU# | CR64 | 1 | 49.90nm |
| CLK_BCLK_CPU# | CR65 | 1 | 49.90nm |
| CLK_BCLK_MCH | CR66 | 1 | 49.90nm |
| CLK_BCLK_MCH# | CR67 | 1 | 49.90nm |
| CLK_BCLK_ITP | CR68 | 1 | 49.90nm |
| CLK_BCLK_ITP# | CR69 | 1 | 49.90nm |
| CLK_PCIE_MCH | CR70 | 1 | 49.90nm |
| CLK_PCIE_MCH# | CR71 | 1 | 49.90nm |
| CLK_PCIE_ICH | CR72 | 1 | 49.90nm |
| CLK_PCIE_ICH# | CR73 | 1 | 49.90nm |
| CLK_PCIE_MINICARD# | CR74 | 1 | 49.90nm |
| CLK_PCIE_MINICARD# | CR75 | 1 | 49.90nm |
| CLK_PCIE_LAN# | CR76 | 1 | 49.90nm |
| CLK_PCIE_LAN# | CR77 | 1 | 49.90nm |
| CLK_96M_UMA# | CR78 | 1 | 49.90nm |
| CLK_96M_UMA# | CR79 | 1 | 49.90nm |
| CLK_LCD_LVDS# | CR80 | 1 | 49.90nm |
| CLK_LCD_LVDS# | CR81 | 1 | 49.90nm |
| CLK_BCLK_CPU | CC15 | 2 | 10PF/50V |
| CLK_BCLK_CPU# | CC16 | 2 | 10PF/50V |
| CLK_BCLK_MCH | CC17 | 2 | 10PF/50V |
| CLK_BCLK_MCH# | CC18 | 2 | 10PF/50V |
| CLK_BCLK_ITP | CC19 | 2 | 10PF/50V |
| CLK_BCLK_ITP# | CC20 | 2 | 10PF/50V |
| CLK_PCIE_MCH# | CC21 | 2 | 10PF/50V |
| CLK_PCIE_ICH | CC22 | 2 | 10PF/50V |
| CLK_PCIE_ICH# | CC23 | 2 | 10PF/50V |
| CLK_PCIE_MINICARD | CC24 | 2 | 10PF/50V |
| CLK_PCIE_MINICARD# | CC25 | 2 | 10PF/50V |
| CLK_PCIE_LAN | CC26 | 2 | 10PF/50V |
| CLK_PCIE_LAN# | CC27 | 2 | 10PF/50V |
| CLK_96M_UMA# | CC28 | 2 | 10PF/50V |
| CLK_96M_UMA# | CC29 | 2 | 10PF/50V |
| CLK_LCD_LVDS | CC30 | 2 | 10PF/50V |
| CLK_LCD_LVDS# | CC31 | 2 | 10PF/50V |
| CLK_PCL_ICH | CC32 | 2 | 10PF/50V |
| CLK_PCL_ICH# | CC33 | 2 | 10PF/50V |
| CLK_PCL_EC | CC34 | 2 | 10PF/50V |
| CLK_PCL_DEBUG | CC35 | 2 | 10PF/50V |
| CLK_REF_ICH | CC36 | 2 | 10PF/50V |
| CLK_48M_USB | CC37 | 2 | 10PF/50V |

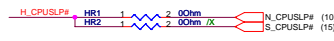
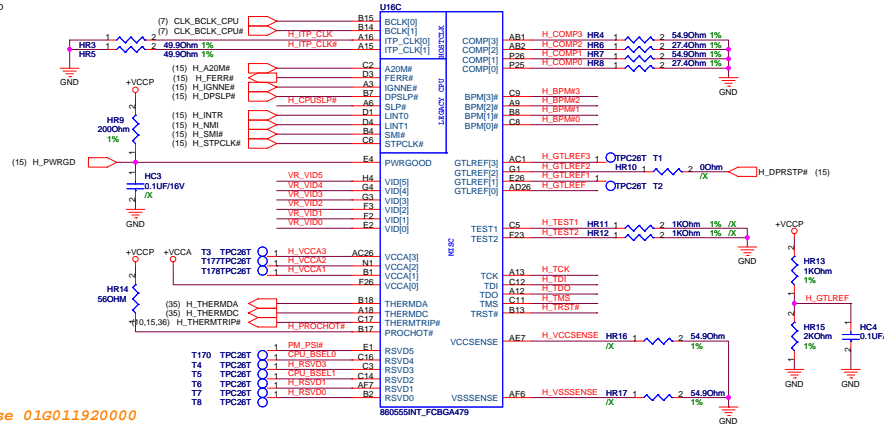

Table with columns for pin names (e.g., H_DM15, H_DM14) and component values (e.g., C25, C24, C23).



U16 use 01G011920000

Table with columns for pin names (e.g., H_AD16, H_AD15) and component values (e.g., A2, A1, A0).

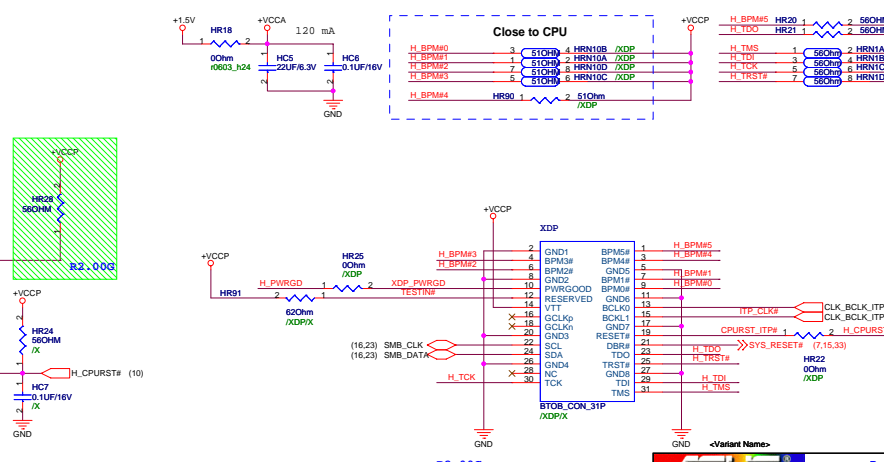
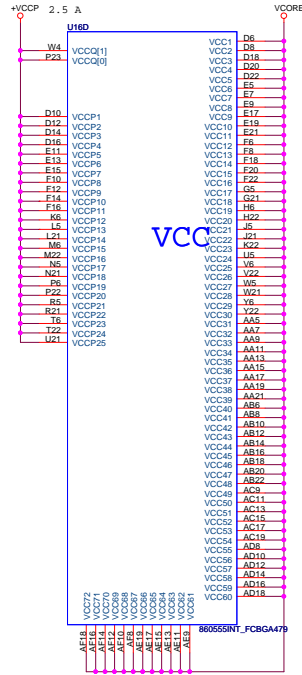

Table with columns for pin names (e.g., H_AD16, H_AD15) and component values (e.g., A2, A1, A0).



ASUS logo and project information: Title: Dothan_HOST, Engineer: Kell_Huang, Project Name: P700, Date: 11/13/2007, Sheet 8 of 48.



Celeron-M(Dothan) ULV max 7 A

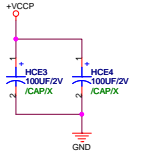
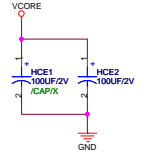

U16 use 01G011920000

0.1U All X7R

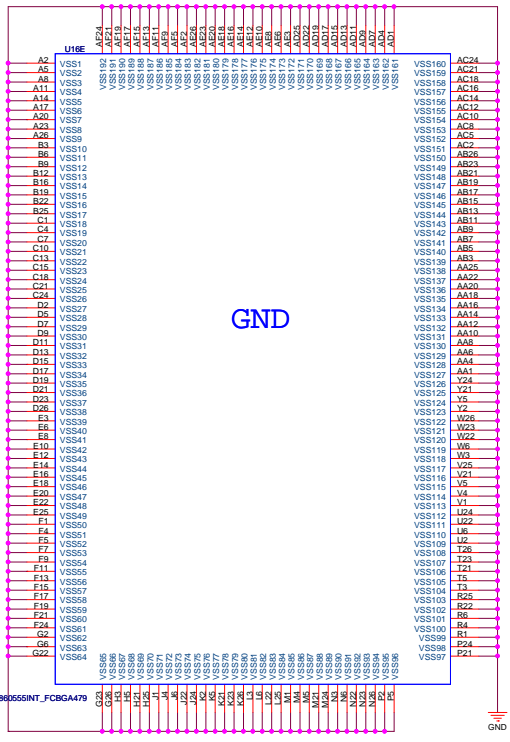
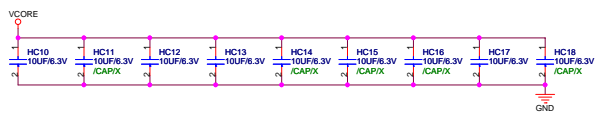
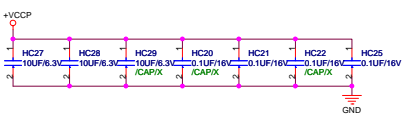
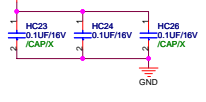

GND

ASUS Title: Dothan_PWR_GND
 ASUSTek Computer INC. Engineer: Kell Huang
 Size: A3 Project Name: P700 Rev: R2.3C
 Date: 08-11-13 2007 Sheet: 9 of 10

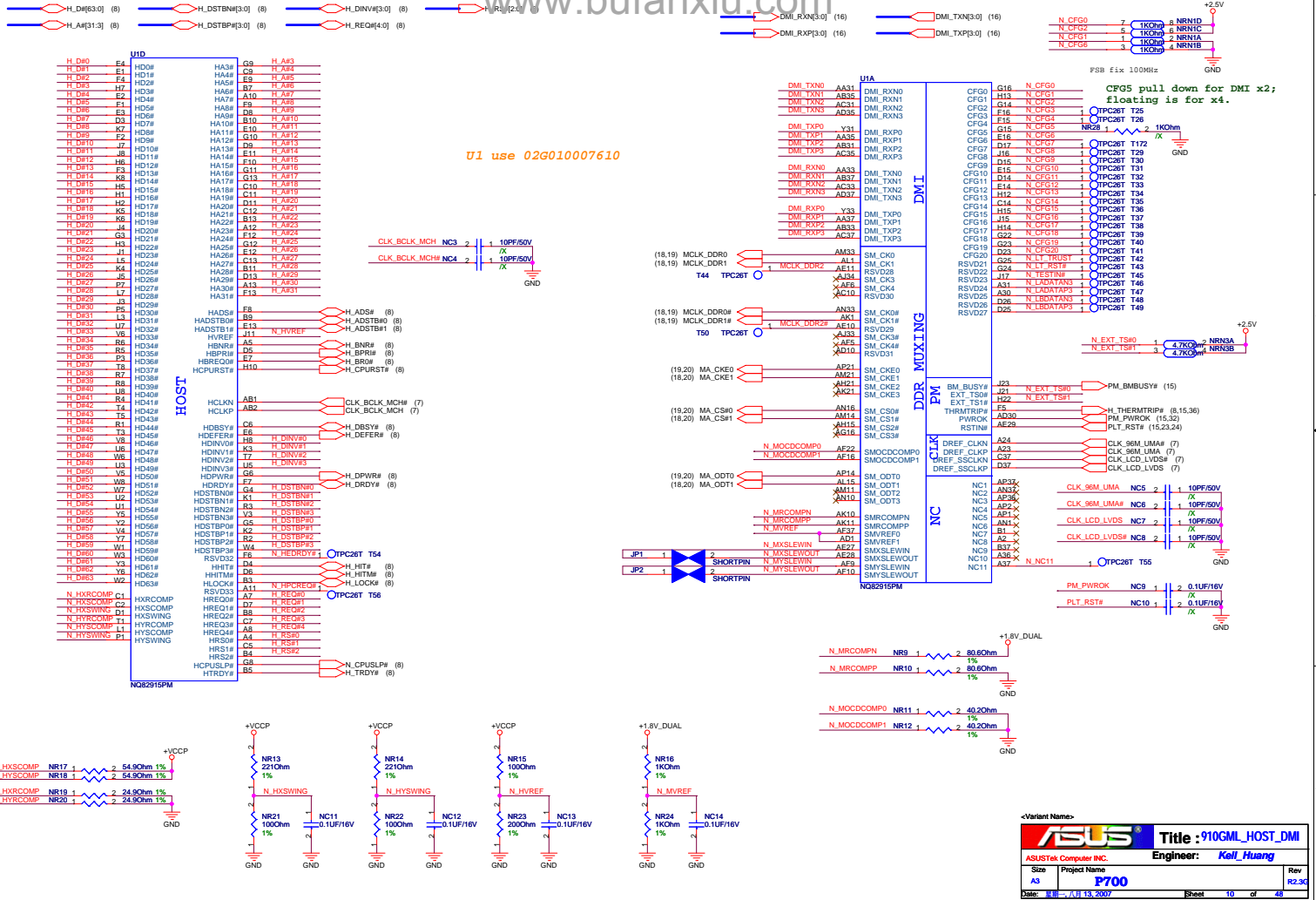

ASUS
ASUSTek Computer INC.
Project Name: P700
Title: 910GML_HOST_DMI
Engineer: Kell Huang
Rev: R2.3C
Date: 11/13/2007
Sheet: 10 of 48



U1 use 02G010007610

| U1B | | AK15 | | MA_BA0 | |
|---------|------|---------|--------------|--------|---------------------------|
| MA_DQ0 | AG35 | SA_D00 | SA_B50 | MA_BA0 | |
| MA_DQ1 | AH35 | SA_D01 | SA_B51 | MA_BA1 | |
| MA_DQ2 | AL35 | SA_D02 | SA_B52 | MA_BA2 | |
| MA_DQ3 | AL37 | SA_D03 | | | |
| MA_DQ4 | AK36 | SA_D04 | SA_DM0 | MA_DM0 | |
| MA_DQ5 | AJ35 | SA_D05 | SA_DM1 | MA_DM1 | |
| MA_DQ6 | AK37 | SA_D06 | SA_DM2 | MA_DM2 | |
| MA_DQ7 | AL34 | SA_D07 | SA_DM3 | MA_DM3 | |
| MA_DQ8 | AM36 | SA_D08 | SA_DM4 | MA_DM4 | |
| MA_DQ9 | AK38 | SA_D09 | SA_DM5 | MA_DM5 | |
| MA_DQ10 | AP32 | SA_D09 | SA_DM6 | MA_DM6 | |
| MA_DQ11 | AK41 | SA_D010 | SA_DM7 | MA_DM7 | |
| MA_DQ12 | AK34 | SA_D011 | | | |
| MA_DQ13 | AK36 | SA_D012 | | | |
| MA_DQ14 | AL32 | SA_D013 | SA_DQ50 | AK36 | MA_DQ50 |
| MA_DQ15 | AK32 | SA_D014 | SA_DQ51 | AK36 | MA_DQ51 |
| MA_DQ16 | AK31 | SA_D015 | SA_DQ52 | AK36 | MA_DQ52 |
| MA_DQ17 | AP31 | SA_D016 | SA_DQ53 | AK36 | MA_DQ53 |
| MA_DQ18 | AK38 | SA_D017 | SA_DQ54 | AK36 | MA_DQ54 |
| MA_DQ19 | AK38 | SA_D018 | SA_DQ55 | AK36 | MA_DQ55 |
| MA_DQ20 | AL30 | SA_D019 | SA_DQ56 | AK36 | MA_DQ56 |
| MA_DQ21 | AK30 | SA_D020 | SA_DQ57 | AK36 | MA_DQ57 |
| MA_DQ22 | AK32 | SA_D021 | | | |
| MA_DQ23 | AK38 | SA_D022 | SA_DQ58 | AK36 | MA_DQ58 |
| MA_DQ24 | AK32 | SA_D023 | SA_DQ59 | AK36 | MA_DQ59 |
| MA_DQ25 | AK37 | SA_D024 | SA_DQ60 | AK36 | MA_DQ60 |
| MA_DQ26 | AK31 | SA_D025 | SA_DQ61 | AK36 | MA_DQ61 |
| MA_DQ27 | AK32 | SA_D026 | SA_DQ62 | AK36 | MA_DQ62 |
| MA_DQ28 | AL33 | SA_D027 | SA_DQ63 | AK36 | MA_DQ63 |
| MA_DQ29 | AK31 | SA_D028 | SA_DQ64 | AK36 | MA_DQ64 |
| MA_DQ30 | AK32 | SA_D029 | SA_DQ65 | AK36 | MA_DQ65 |
| MA_DQ31 | AK32 | SA_D030 | | | |
| MA_DQ32 | AK32 | SA_D031 | SA_MA0 | AL17 | MA_MA0 |
| MA_DQ33 | AL38 | SA_D032 | SA_MA1 | AL17 | MA_MA1 |
| MA_DQ34 | AL38 | SA_D033 | SA_MA2 | AL17 | MA_MA2 |
| MA_DQ35 | AK37 | SA_D034 | SA_MA3 | AL17 | MA_MA3 |
| MA_DQ36 | AK37 | SA_D035 | SA_MA4 | AL17 | MA_MA4 |
| MA_DQ37 | AK37 | SA_D036 | SA_MA5 | AL17 | MA_MA5 |
| MA_DQ38 | AK37 | SA_D037 | SA_MA6 | AL18 | MA_MA6 |
| MA_DQ39 | AK37 | SA_D038 | SA_MA7 | AL19 | MA_MA7 |
| MA_DQ40 | AK37 | SA_D039 | SA_MA8 | AL20 | MA_MA8 |
| MA_DQ41 | AK37 | SA_D040 | SA_MA9 | AL20 | MA_MA9 |
| MA_DQ42 | AK37 | SA_D041 | SA_MA10 | AL20 | MA_MA10 |
| MA_DQ43 | AK37 | SA_D042 | SA_MA11 | AL20 | MA_MA11 |
| MA_DQ44 | AK37 | SA_D043 | SA_MA12 | AL20 | MA_MA12 |
| MA_DQ45 | AK37 | SA_D044 | SA_MA13 | AL20 | MA_MA13 |
| MA_DQ46 | AK37 | SA_D045 | | | |
| MA_DQ47 | AK37 | SA_D046 | SA_CAS# | AN15 | MA_CAS# (18,19,20) |
| MA_DQ48 | AK37 | SA_D047 | SA_RAS# | AP16 | MA_RAS# (18,19,20) |
| MA_DQ49 | AK37 | SA_D048 | SA_RCVENIN# | AF28 | MA_RCVENIN# 1 TPC26T T57 |
| MA_DQ50 | AK37 | SA_D049 | SA_RCVENOUT# | AF28 | MA_RCVENOUT# 1 TPC26T T58 |
| MA_DQ51 | AK37 | SA_D050 | SA_WE# | AP15 | MA_WE# (18,19,20) |
| MA_DQ52 | AK37 | SA_D051 | | | |
| MA_DQ53 | AK37 | SA_D052 | | | |
| MA_DQ54 | AK37 | SA_D053 | | | |
| MA_DQ55 | AK37 | SA_D054 | | | |
| MA_DQ56 | AK37 | SA_D055 | | | |
| MA_DQ57 | AK37 | SA_D056 | | | |
| MA_DQ58 | AK37 | SA_D057 | | | |
| MA_DQ59 | AK37 | SA_D058 | | | |
| MA_DQ60 | AK37 | SA_D059 | | | |
| MA_DQ61 | AK37 | SA_D060 | | | |
| MA_DQ62 | AK37 | SA_D061 | | | |
| MA_DQ63 | AK37 | SA_D062 | | | |
| MA_DQ64 | AK37 | SA_D063 | | | |

DDR SYSTEM MEMORY A

U1C

| | | |
|------|---------|--------------|
| AE31 | SB_D00 | AH15 |
| AE32 | SB_D01 | AG12 |
| AE33 | SB_D02 | AG21 |
| AE34 | SB_D03 | AG22 |
| AE35 | SB_D04 | |
| AE36 | SB_D05 | SB_DM0 |
| AE37 | SB_D06 | SB_DM1 |
| AE38 | SB_D07 | SB_DM2 |
| AE39 | SB_D08 | SB_DM3 |
| AE40 | SB_D09 | SB_DM4 |
| AE41 | SB_D010 | SB_DM5 |
| AE42 | SB_D011 | SB_DM6 |
| AE43 | SB_D012 | SB_DM7 |
| AE44 | SB_D013 | |
| AE45 | SB_D014 | SB_DQ50 |
| AE46 | SB_D015 | SB_DQ51 |
| AE47 | SB_D016 | SB_DQ52 |
| AE48 | SB_D017 | SB_DQ53 |
| AE49 | SB_D018 | SB_DQ54 |
| AE50 | SB_D019 | SB_DQ55 |
| AE51 | SB_D020 | SB_DQ56 |
| AE52 | SB_D021 | SB_DQ57 |
| AE53 | SB_D022 | |
| AE54 | SB_D023 | SB_DQ58 |
| AE55 | SB_D024 | SB_DQ59 |
| AE56 | SB_D025 | SB_DQ60 |
| AE57 | SB_D026 | SB_DQ61 |
| AE58 | SB_D027 | SB_DQ62 |
| AE59 | SB_D028 | SB_DQ63 |
| AE60 | SB_D029 | SB_DQ64 |
| AE61 | SB_D030 | SB_DQ65 |
| AE62 | SB_D031 | |
| AE63 | SB_D032 | SB_MA0 |
| AE64 | SB_D033 | SB_MA1 |
| AE65 | SB_D034 | SB_MA2 |
| AE66 | SB_D035 | SB_MA3 |
| AE67 | SB_D036 | SB_MA4 |
| AE68 | SB_D037 | SB_MA5 |
| AE69 | SB_D038 | SB_MA6 |
| AE70 | SB_D039 | SB_MA7 |
| AE71 | SB_D040 | SB_MA8 |
| AE72 | SB_D041 | SB_MA9 |
| AE73 | SB_D042 | SB_MA10 |
| AE74 | SB_D043 | SB_MA11 |
| AE75 | SB_D044 | SB_MA12 |
| AE76 | SB_D045 | SB_MA13 |
| AE77 | SB_D046 | |
| AE78 | SB_D047 | SB_CAS# |
| AE79 | SB_D048 | SB_RAS# |
| AE80 | SB_D049 | SB_RCVENIN# |
| AE81 | SB_D050 | SB_RCVENOUT# |
| AE82 | SB_D051 | SB_WE# |
| AE83 | SB_D052 | |
| AE84 | SB_D053 | |
| AE85 | SB_D054 | |
| AE86 | SB_D055 | |
| AE87 | SB_D056 | |
| AE88 | SB_D057 | |
| AE89 | SB_D058 | |
| AE90 | SB_D059 | |
| AE91 | SB_D060 | |
| AE92 | SB_D061 | |
| AE93 | SB_D062 | |
| AE94 | SB_D063 | |

DDR SYSTEM MEMORY B

NB82915PM

<Variant Name>

ASUS Title : 910GML_DRAM
 ASUSTek Computer INC. Engineer: Kell_Huang
 Size Project Name Rev
 A3 P700 R2.3C
 Date: 11/13/2007 Sheet 11 of 48

SDVOCTRL_DATA Int PD
 SDVO Smbus have internal pull down
 0 : No SDVO device
 1 : SDVO device present

U1 use 02G010007610

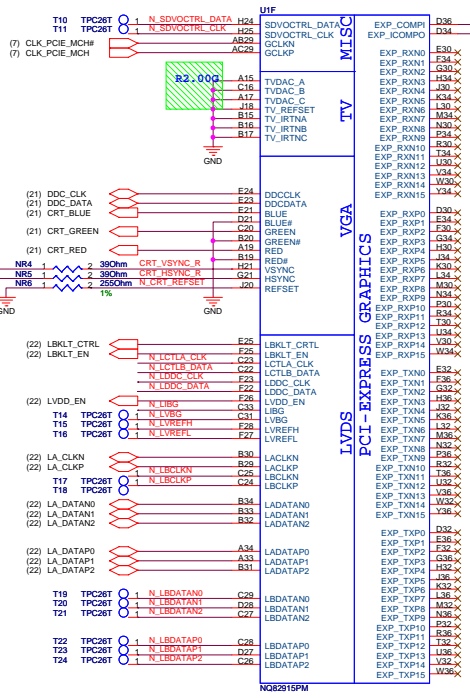
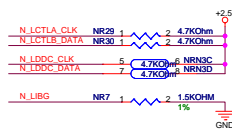
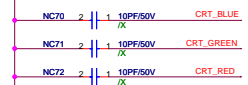
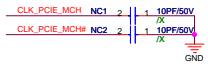

PCI-E signals can be left NC, if unused.

<Variant Name>
ASUS Title : 910GML_VGA_LVDS
 ASUSTek Computer INC. Engineer: Kell_Huang
 Size | Project Name | Rev
 A3 | P700 | R2.3C
 Date: 08-11-13 2007 | Sheet 12 of 48

U1 use 02G010007610

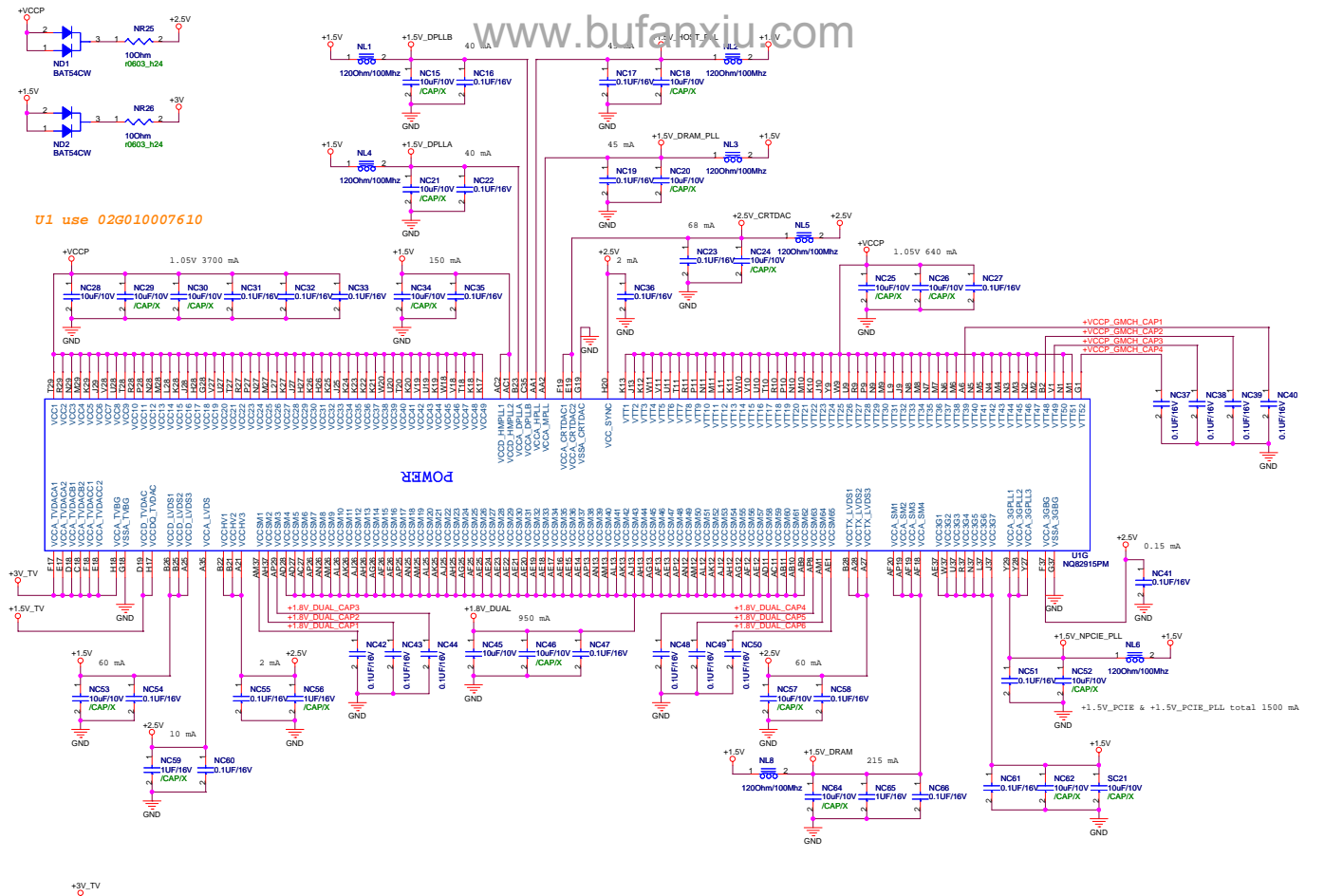

<Variant Name>

Title : 910GML_PWR

ASUSTek Computer INC. **Engineer: Keli_Huang**

| | | |
|---------------------|--------------|-------|
| Size | Project Name | Rev |
| A3 | P700 | R2.3G |
| Date: 08-11-13-2007 | Sheet 13 | of 48 |

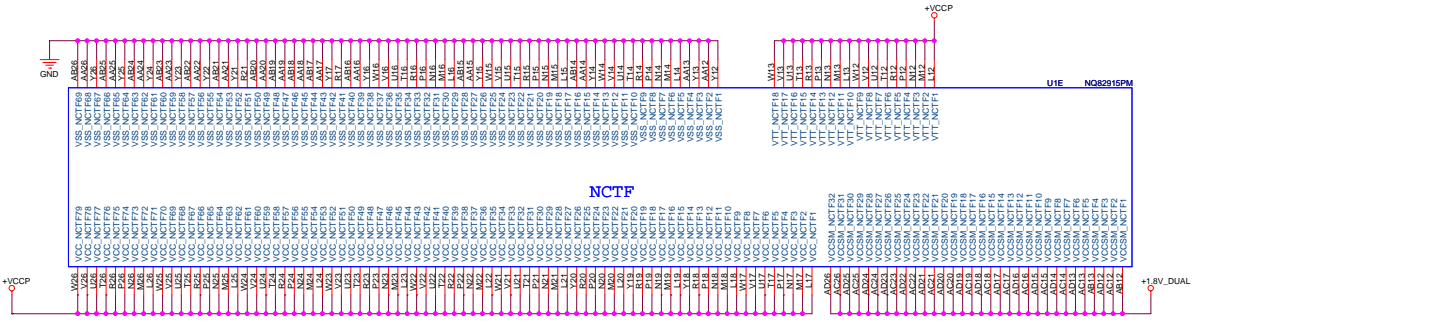

U1 use 02G01007610

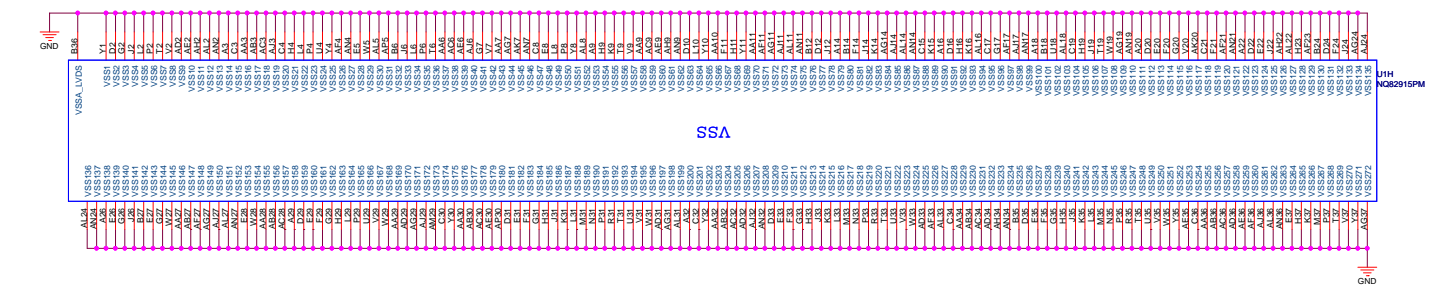

<Variant Name>

Title : 910GML_GND

ASUSTek Computer Inc. **Engineer: Keil_Huang**

| | | |
|------|--------------|-------|
| Size | Project Name | Rev |
| A3 | P700 | R2.3C |

Date: 10-11-13 2007 Sheet 14 of 48

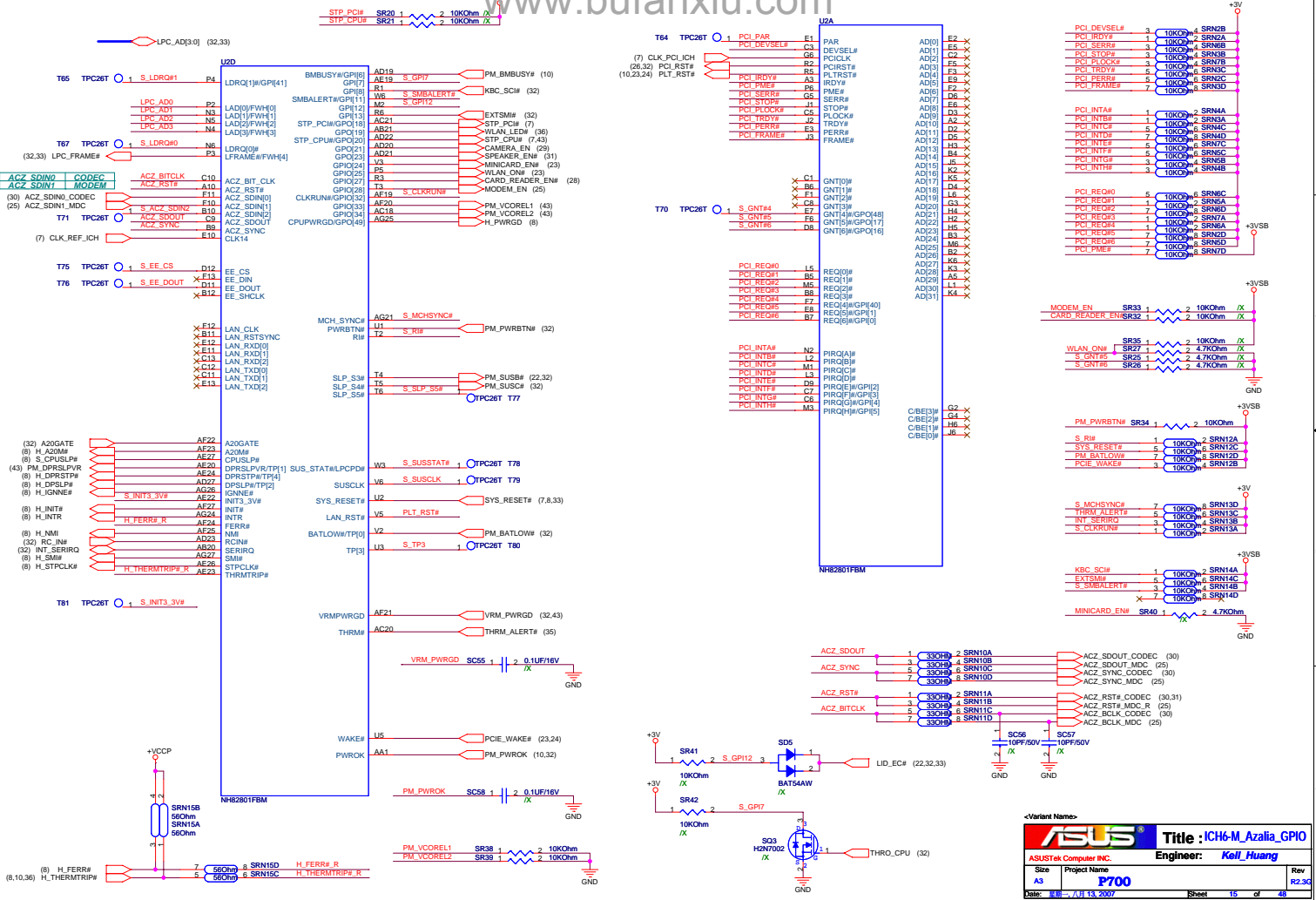

<Variant Name>

| | | | |
|-----------------------|--------------------|----------------------------------|--|
| ASUS | | Title: ICH6-M_Azalia_GPIO | |
| ASUSTek Computer INC. | | Engineer: Kell Huang | |
| Size: A3 | Project Name: P700 | Rev: R2.3C | |
| Date: 11/13/2007 | Sheet: 15 | of: 48 | |

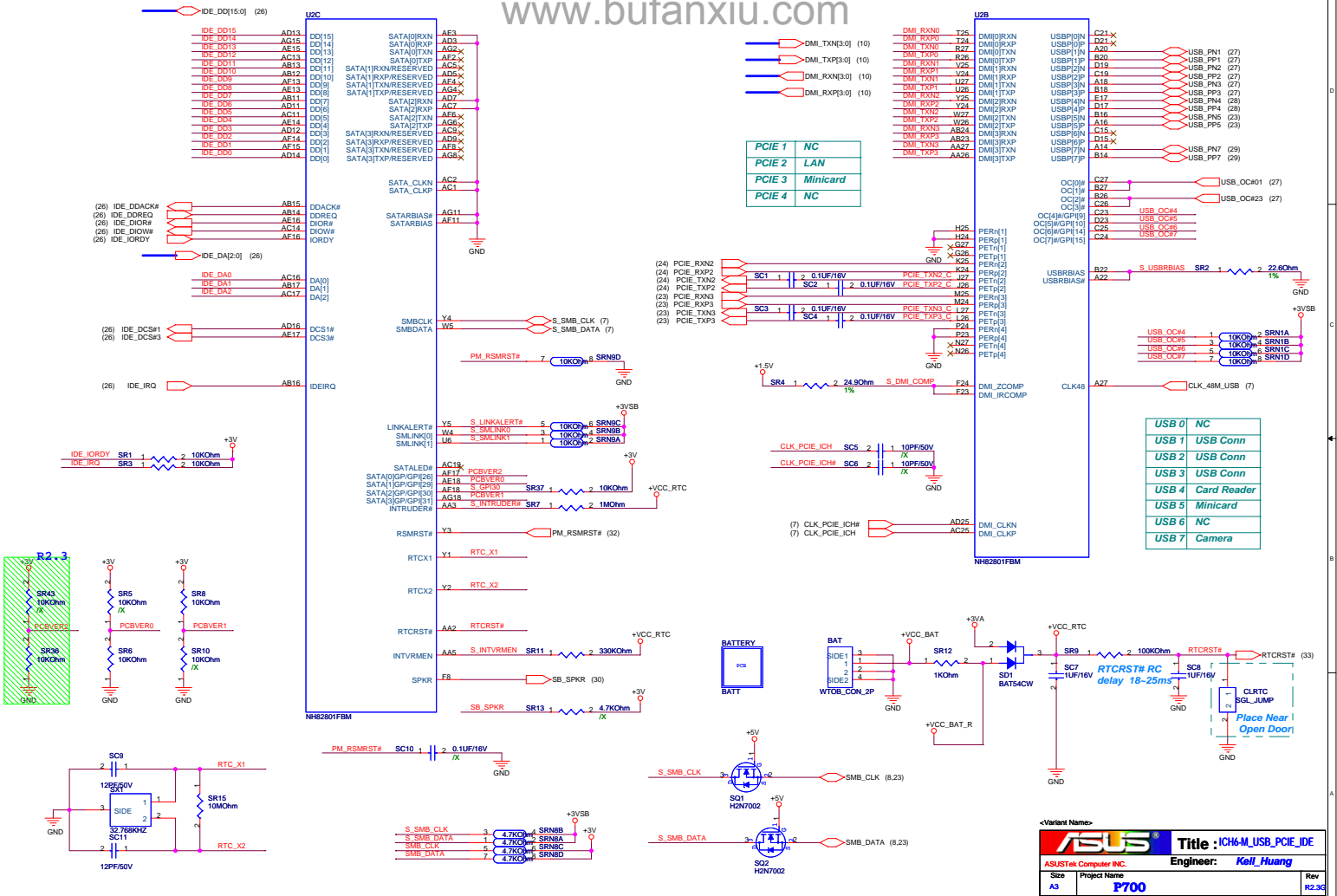

| | |
|--------|----------|
| PCIE 1 | NC |
| PCIE 2 | LAN |
| PCIE 3 | Minicard |
| PCIE 4 | NC |

| | |
|-------|-------------|
| USB 0 | NC |
| USB 1 | USB Conn |
| USB 2 | USB Conn |
| USB 3 | USB Conn |
| USB 4 | Card Reader |
| USB 5 | Minicard |
| USB 6 | NC |
| USB 7 | Camera |

ASUS Logo

Title: ICH6M_USB_PCIE_IDE

ASUSTek Computer INC. Project Name: P700

Engineer: Keli_Huang

Date: 11/13/2007

Sheet: 16 of 48

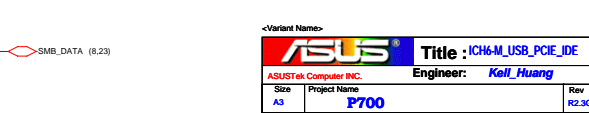
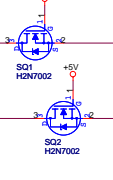
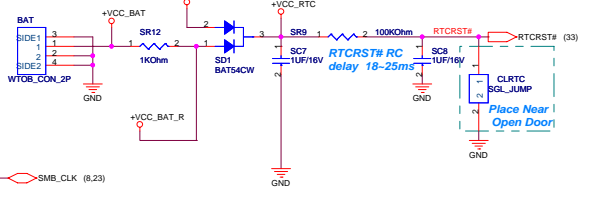
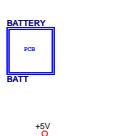
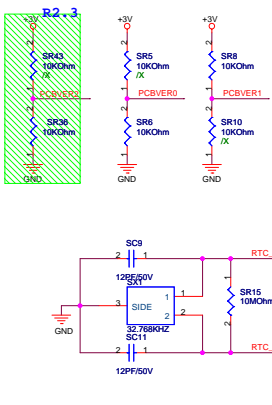

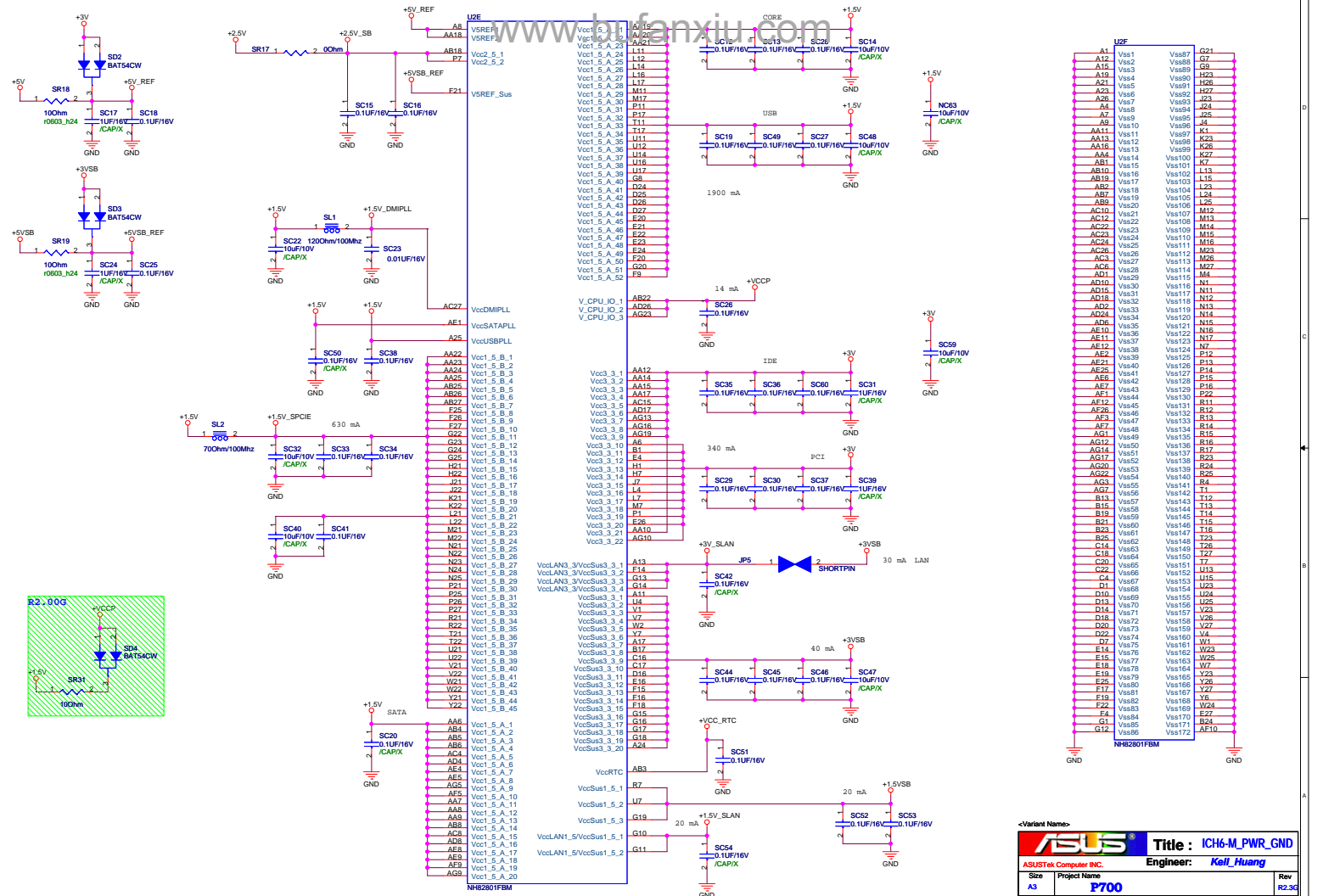

| U2F | U2F | U2F |
|------|-------|--------|
| A1 | Vas1 | Vas87 |
| A12 | Vas2 | Vas88 |
| A16 | Vas3 | Vas89 |
| A21 | Vas4 | Vas90 |
| A26 | Vas5 | Vas91 |
| A31 | Vas6 | Vas92 |
| A36 | Vas7 | Vas93 |
| A41 | Vas8 | Vas94 |
| A46 | Vas9 | Vas95 |
| A51 | Vas10 | Vas96 |
| A56 | Vas11 | Vas97 |
| A61 | Vas12 | Vas98 |
| A66 | Vas13 | Vas99 |
| A71 | Vas14 | Vas100 |
| A76 | Vas15 | Vas101 |
| A81 | Vas16 | Vas102 |
| A86 | Vas17 | Vas103 |
| A91 | Vas18 | Vas104 |
| A96 | Vas19 | Vas105 |
| A101 | Vas20 | Vas106 |
| A106 | Vas21 | Vas107 |
| A111 | Vas22 | Vas108 |
| A116 | Vas23 | Vas109 |
| A121 | Vas24 | Vas110 |
| A126 | Vas25 | Vas111 |
| A131 | Vas26 | Vas112 |
| A136 | Vas27 | Vas113 |
| A141 | Vas28 | Vas114 |
| A146 | Vas29 | Vas115 |
| A151 | Vas30 | Vas116 |
| A156 | Vas31 | Vas117 |
| A161 | Vas32 | Vas118 |
| A166 | Vas33 | Vas119 |
| A171 | Vas34 | Vas120 |
| A176 | Vas35 | Vas121 |
| A181 | Vas36 | Vas122 |
| A186 | Vas37 | Vas123 |
| A191 | Vas38 | Vas124 |
| A196 | Vas39 | Vas125 |
| A201 | Vas40 | Vas126 |
| A206 | Vas41 | Vas127 |
| A211 | Vas42 | Vas128 |
| A216 | Vas43 | Vas129 |
| A221 | Vas44 | Vas130 |
| A226 | Vas45 | Vas131 |
| A231 | Vas46 | Vas132 |
| A236 | Vas47 | Vas133 |
| A241 | Vas48 | Vas134 |
| A246 | Vas49 | Vas135 |
| A251 | Vas50 | Vas136 |
| A256 | Vas51 | Vas137 |
| A261 | Vas52 | Vas138 |
| A266 | Vas53 | Vas139 |
| A271 | Vas54 | Vas140 |
| A276 | Vas55 | Vas141 |
| A281 | Vas56 | Vas142 |
| A286 | Vas57 | Vas143 |
| A291 | Vas58 | Vas144 |
| A296 | Vas59 | Vas145 |
| A301 | Vas60 | Vas146 |
| A306 | Vas61 | Vas147 |
| A311 | Vas62 | Vas148 |
| A316 | Vas63 | Vas149 |
| A321 | Vas64 | Vas150 |
| A326 | Vas65 | Vas151 |
| A331 | Vas66 | Vas152 |
| A336 | Vas67 | Vas153 |
| A341 | Vas68 | Vas154 |
| A346 | Vas69 | Vas155 |
| A351 | Vas70 | Vas156 |
| A356 | Vas71 | Vas157 |
| A361 | Vas72 | Vas158 |
| A366 | Vas73 | Vas159 |
| A371 | Vas74 | Vas160 |
| A376 | Vas75 | Vas161 |
| A381 | Vas76 | Vas162 |
| A386 | Vas77 | Vas163 |
| A391 | Vas78 | Vas164 |
| A396 | Vas79 | Vas165 |
| A401 | Vas80 | Vas166 |
| A406 | Vas81 | Vas167 |
| A411 | Vas82 | Vas168 |
| A416 | Vas83 | Vas169 |
| A421 | Vas84 | Vas170 |
| A426 | Vas85 | Vas171 |
| A431 | Vas86 | Vas172 |
| A436 | Vas87 | AE10 |

<Variant Name>



Title : ICH6-M_PWR_GND

ASUSTek Computer INC. **Engineer: Kell Huang**

Size A3 Project Name **P700** Rev **R2.3C**

Date: **11/13/2007** Sheet **17** of **48**

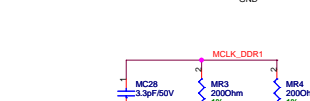
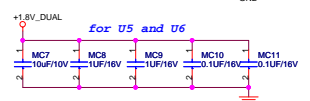
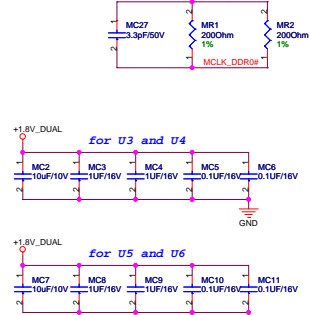
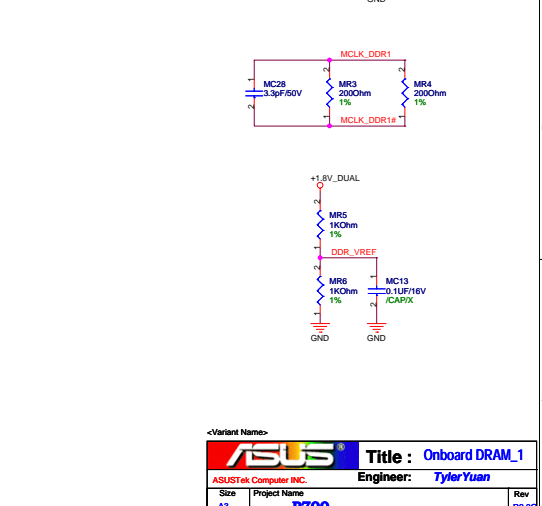
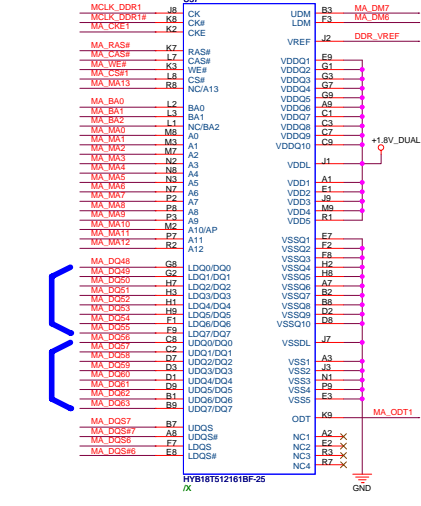
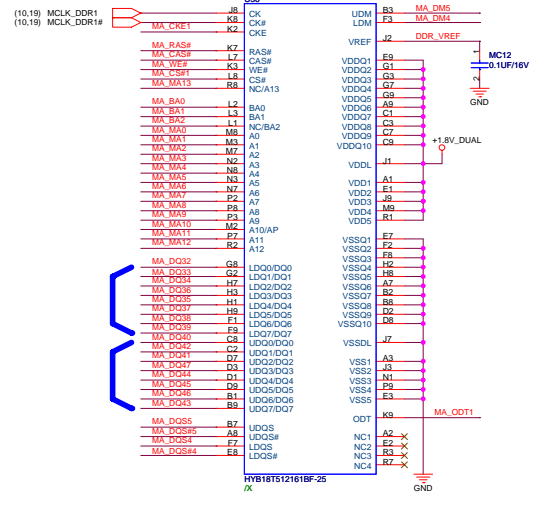
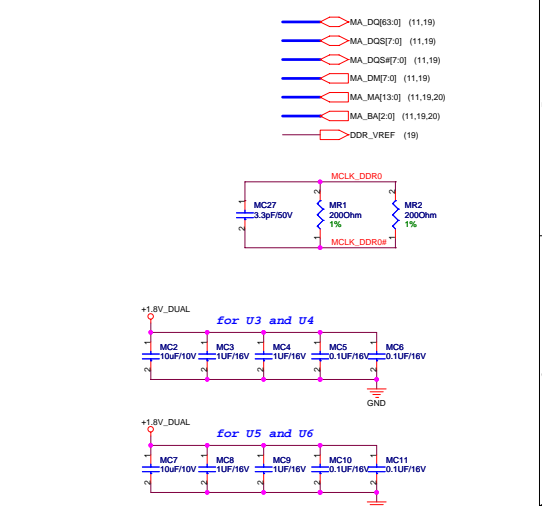
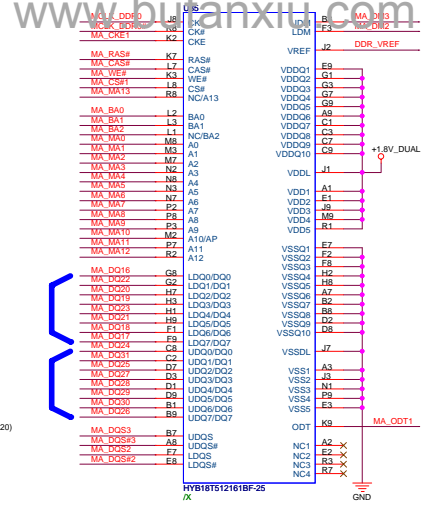
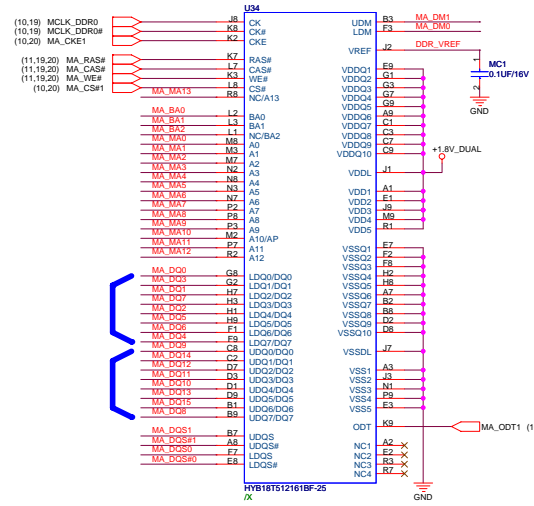

ASUS Logo, Title: Onboard DRAM_1, Engineer: Tyler Yuan, Project Name: P700, Date: 06-17-2007, Sheet: 18 of 48

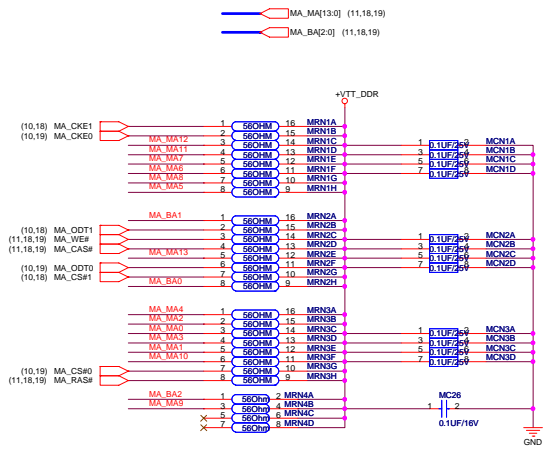

<Variant Name>

| | | | |
|-----------------------|--------------|---------------------------------|-------|
| ASUS | | Title : DDR2 Termination | |
| ASUSTek Computer INC. | | Engineer: <i>Tyler Yuan</i> | |
| Size | Project Name | | Rev |
| A3 | P700 | | R2.3G |
| Date: 11/13/2007 | | Sheet 20 | of 48 |

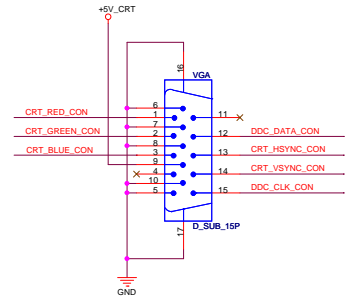
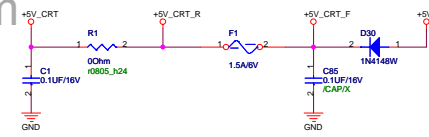
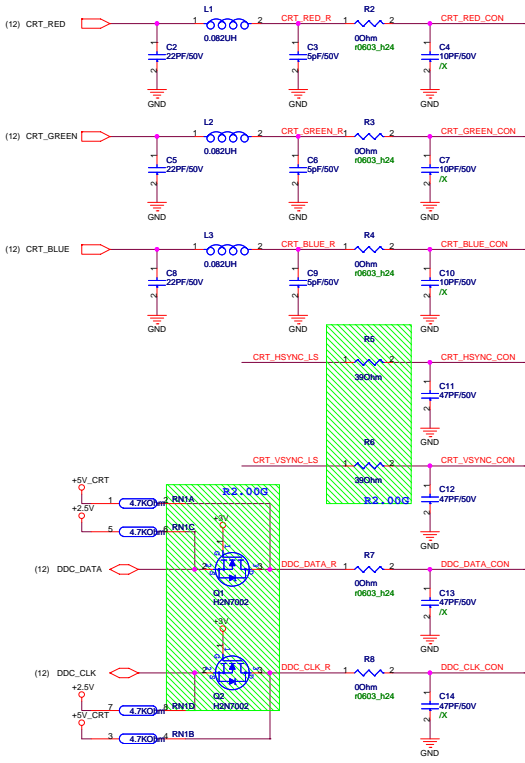

VGA use 12G10110015W or 12G10110015N

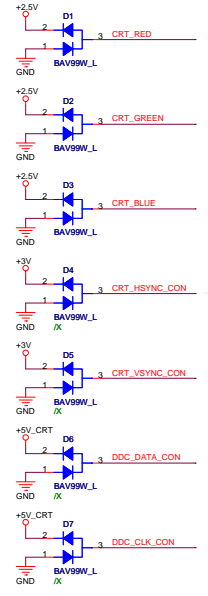
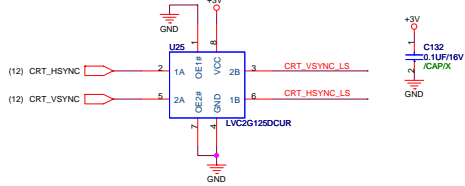

<Variant Name>

| | | | |
|-----------------------|--------------|-----------------------------|----------|
| ASUS | | Title : Onboard VGA | |
| ASUSTek Computer INC. | | Engineer: Kell_Huang | |
| Size | Project Name | | Rev |
| A3 | P700 | | R2.3G |
| Date: | 11/13/2007 | Sheet | 21 of 48 |

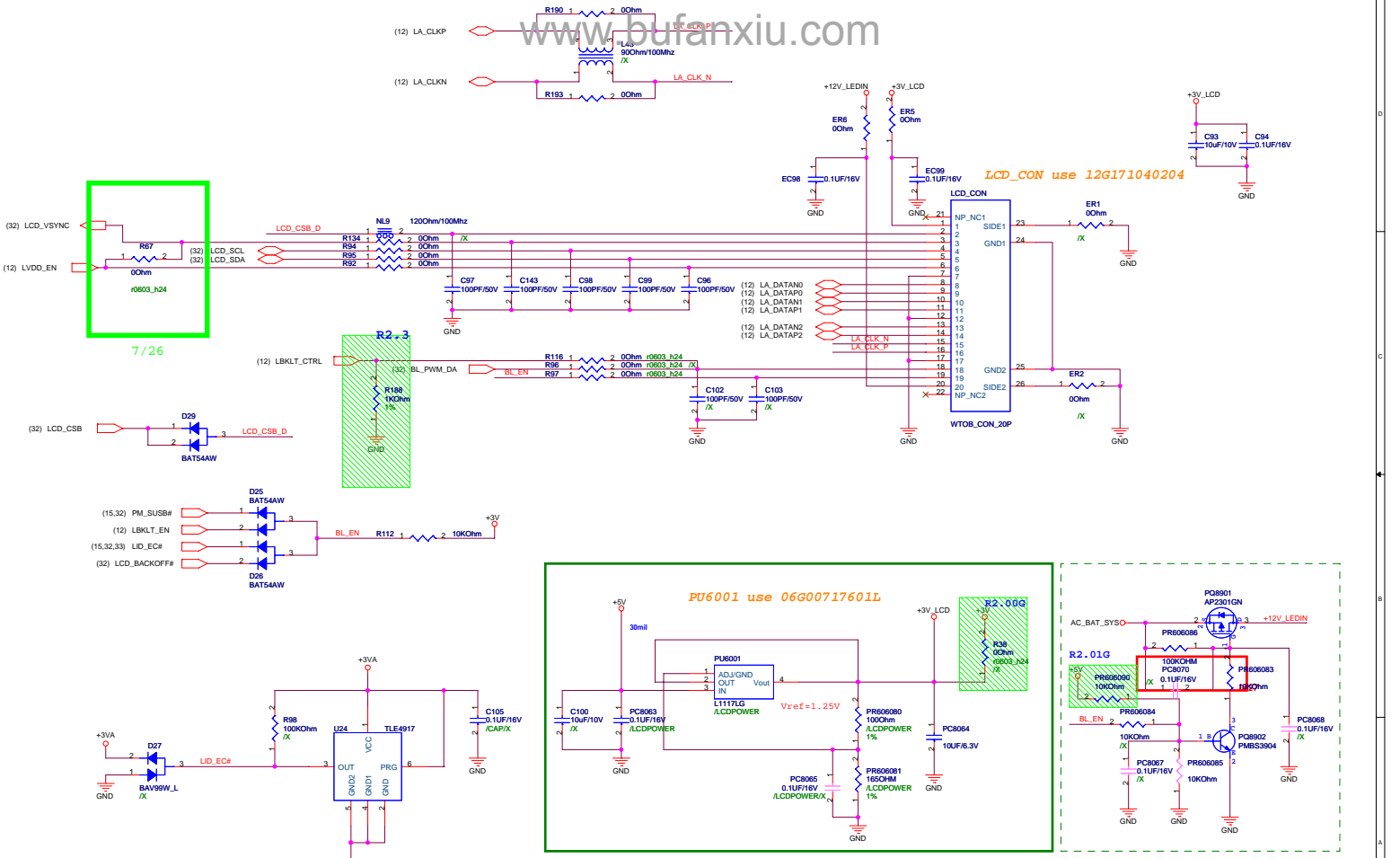

<Variant Name>

ASUS Title: LCD Conn
 ASUSTek Computer INC. Engineer: Keli_Huang
 Size: A3 Project Name: P700 Rev: R2.3G
 Date: 11/13/2007 Sheet: 22 of 48

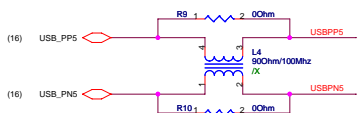

MINICARD use 12G03010052Q

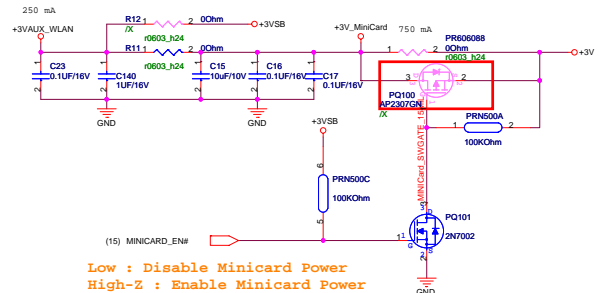
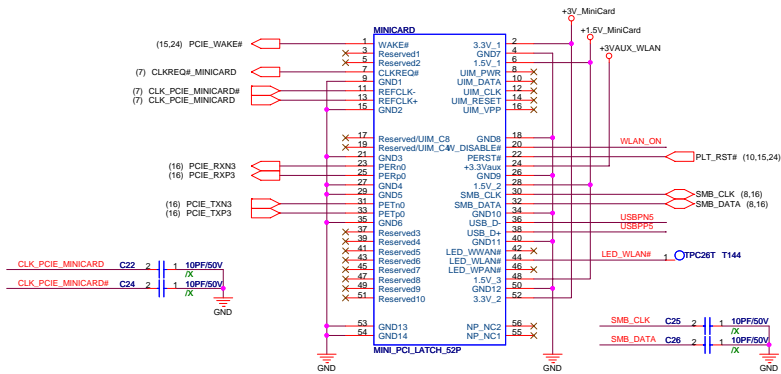

Low : Disable Minicard Power
High-Z : Enable Minicard Power

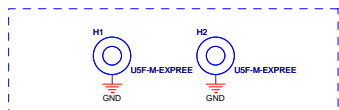

MINI CARD NUT(1.6mm) *2

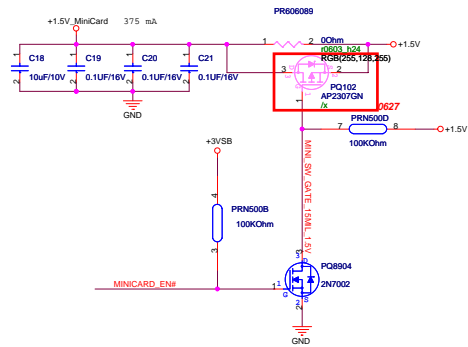
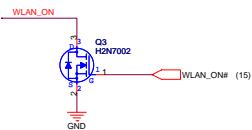
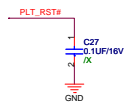

| | | | |
|-----------------------|--------------|----------------------|----------|
| ASUS | | Title : Minicard | |
| ASUSTek Computer INC. | | Engineer: Keli_Huang | |
| Size | Project Name | | Rev |
| A3 | P700 | | R2.3C |
| Date: 11/13/2007 | | Sheet | 23 of 48 |

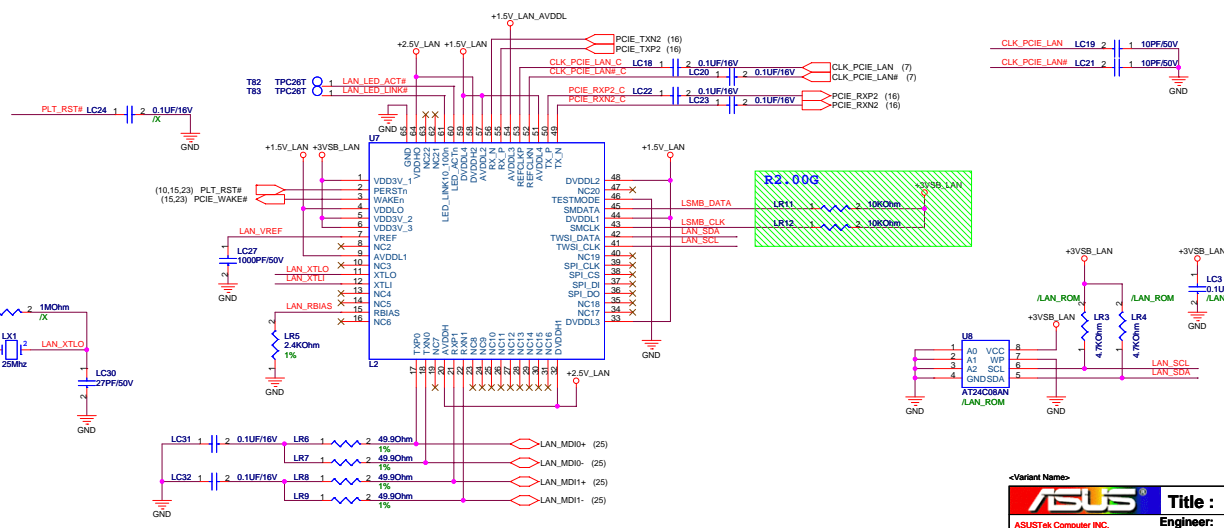
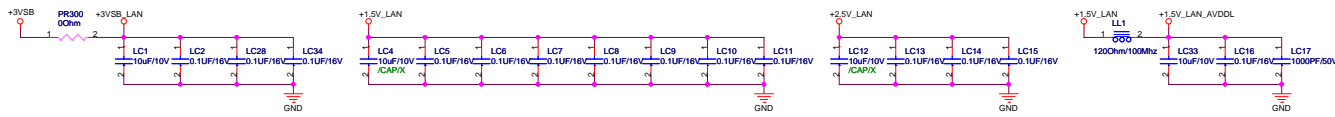

<Variant Name>

Title : LAN_Atheros L2

ASUSTek Computer INC. Engineer: *Kell_Huang*

| | | |
|------|--------------|-------|
| Size | Project Name | Rev |
| A3 | P700 | R2.3C |

Date: 11/13/2007 Sheet 24 of 48

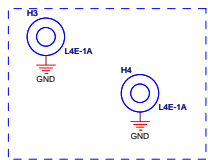

MODEM NUT(3.0mm) *2

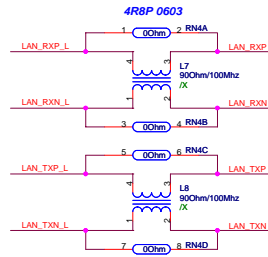
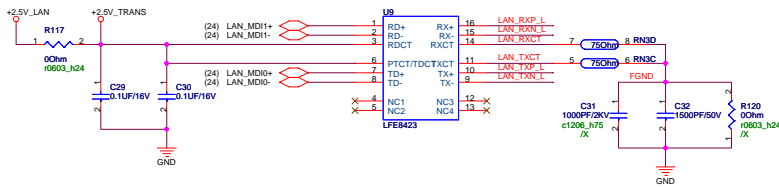
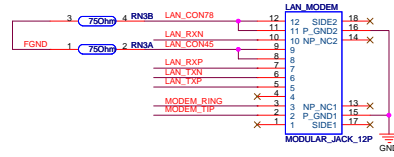
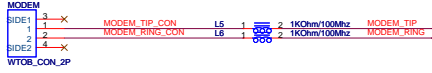
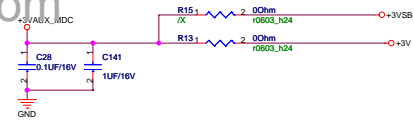
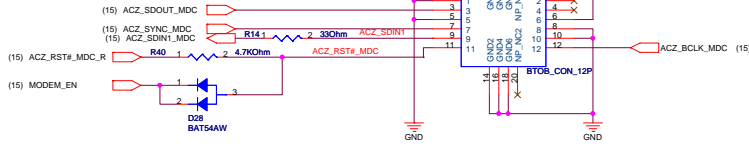

<Variant Name>

| | | | |
|-----------------------|--------------------|------------------------------|--|
| ASUS | | Title : MDC_RJ11_RJ45 | |
| ASUSTek Computer INC. | | Engineer: <i>Kell_Huang</i> | |
| Size: A3 | Project Name: P700 | Rev: R2.3G | |
| Date: 11/13/2007 | Sheet: 25 | of 48 | |

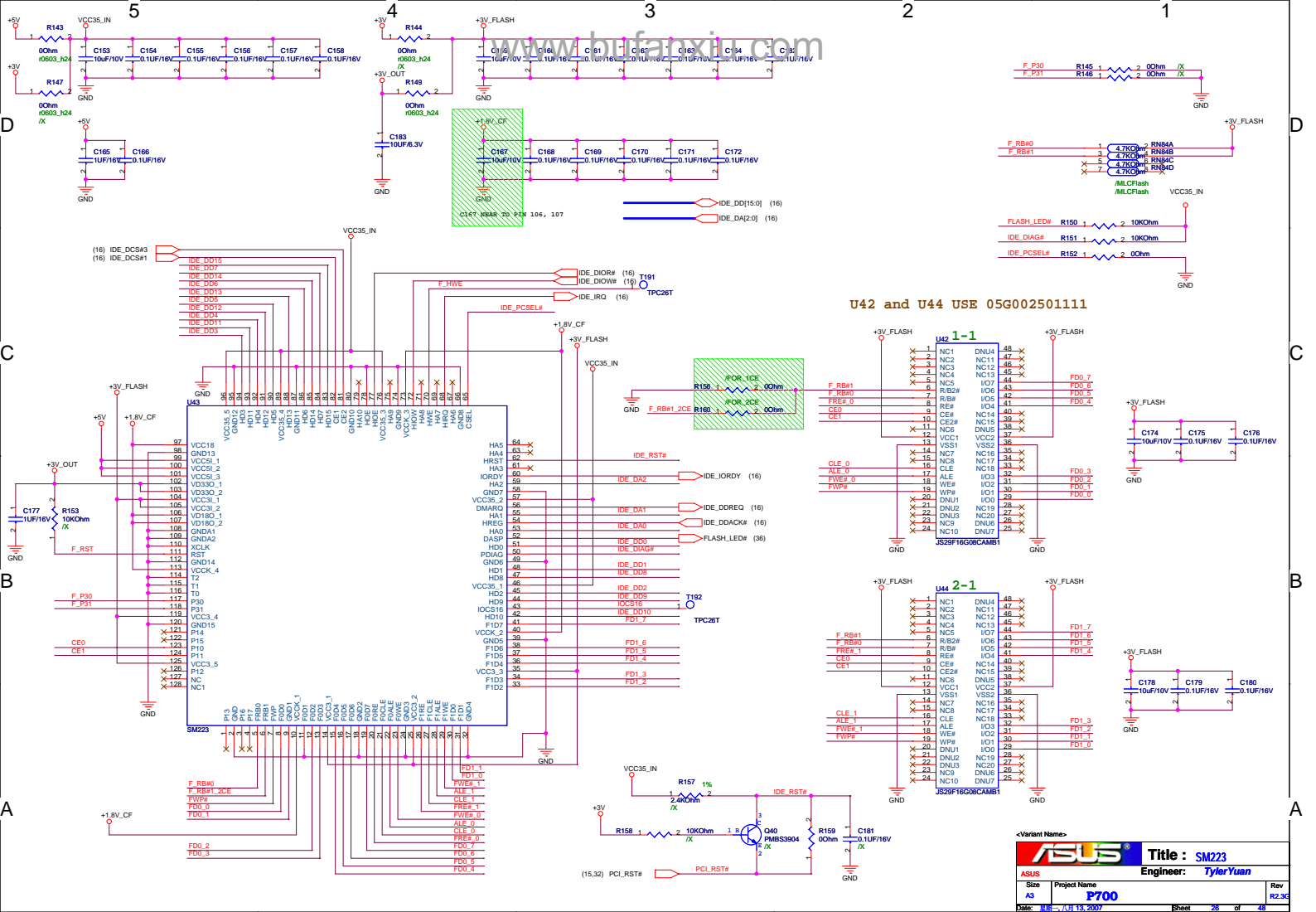

U42 and U44 USE 05G002501111

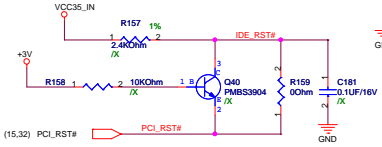
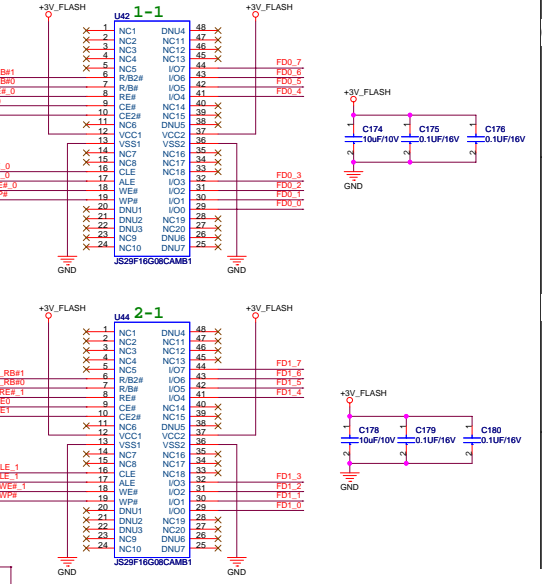

| | | | |
|------------------------|--------------------|---------------------|------------|
| ASUS | | Title: SM223 | |
| Size: A3 | Project Name: P700 | Engineer: TylerYuan | Rev: R2.3C |
| Date: 10-17-11 13:2007 | Sheet: 28 | of | 48 |

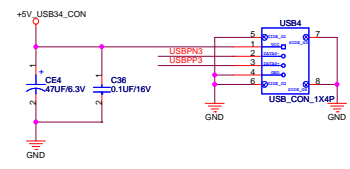
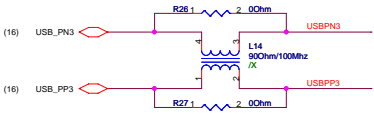
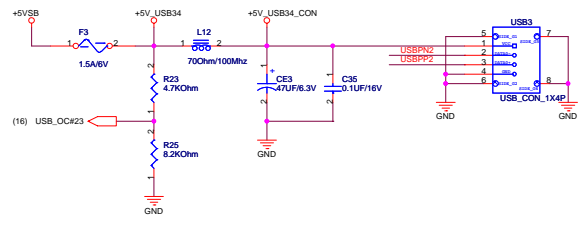
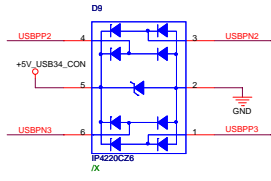
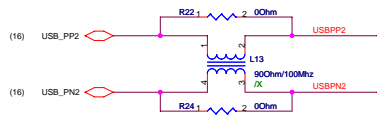
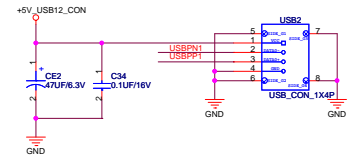
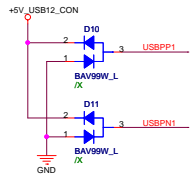
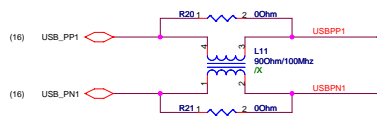
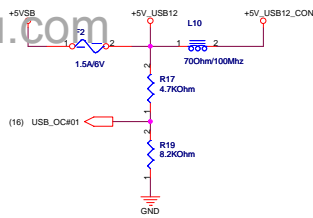

<Variant Name>

| | | | |
|-----------------------|--------------|-----------------------------|-------|
| ASUS | | Title : USB Port | |
| ASUSTek Computer INC. | | Engineer: <i>Kell_Huang</i> | |
| Size | Project Name | | Rev |
| A3 | P700 | | R2.3G |
| Date: 11/13/2007 | | Sheet 27 | of 48 |

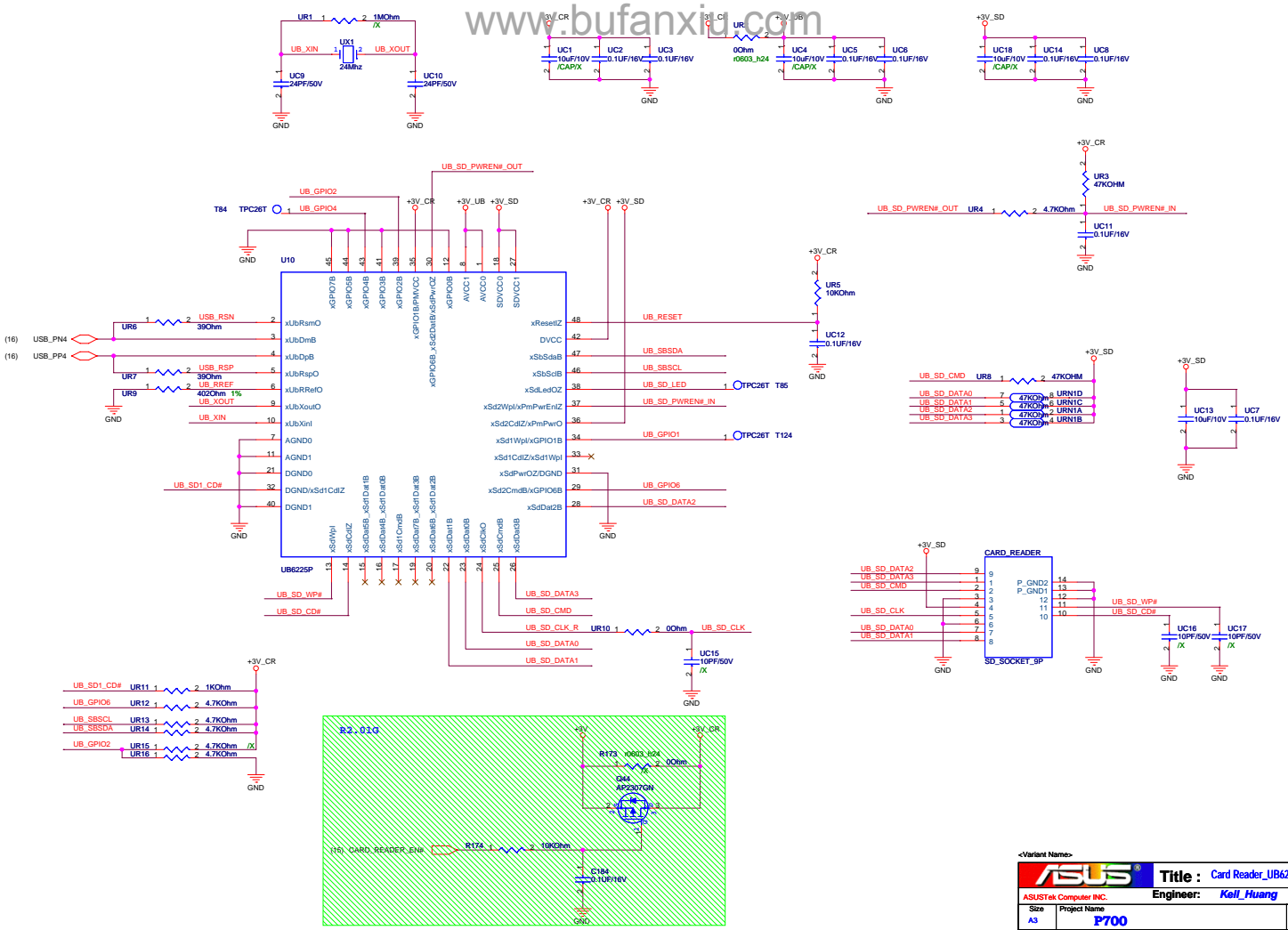

<Variant Name>

| | | | |
|-----------------------|--|-----------------------------------|--|
| ASUS | | Title : Card Reader_UB625P | |
| ASUSTek Computer INC. | | | |
| Size A3 | | Project Name | |
| P700 | | Engineer: <i>Kell Huang</i> | |
| Date: 11/13/2007 | | Sheet 28 of 48 | |

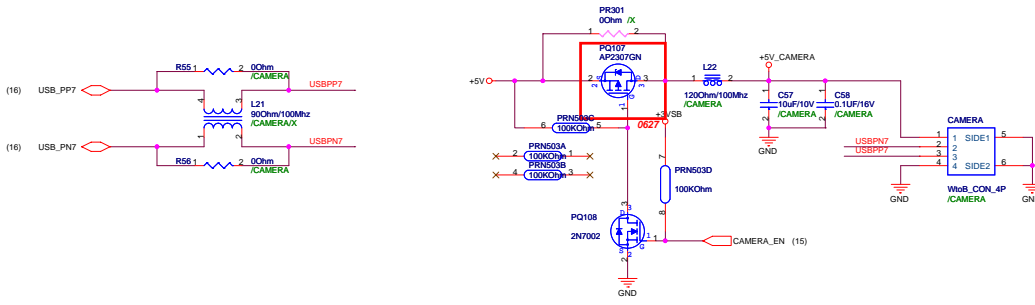

<Variant Name>

| | | | |
|-----------------------|--------------|-----------------------------|-------|
| ASUS | | Title : Camera Conn | |
| ASUSTek Computer INC. | | Engineer: <i>Kell_Huang</i> | |
| Size | Project Name | | Rev |
| A3 | P700 | | R2.3G |
| Date: 11/11/13, 2007 | | Sheet 29 | of 48 |

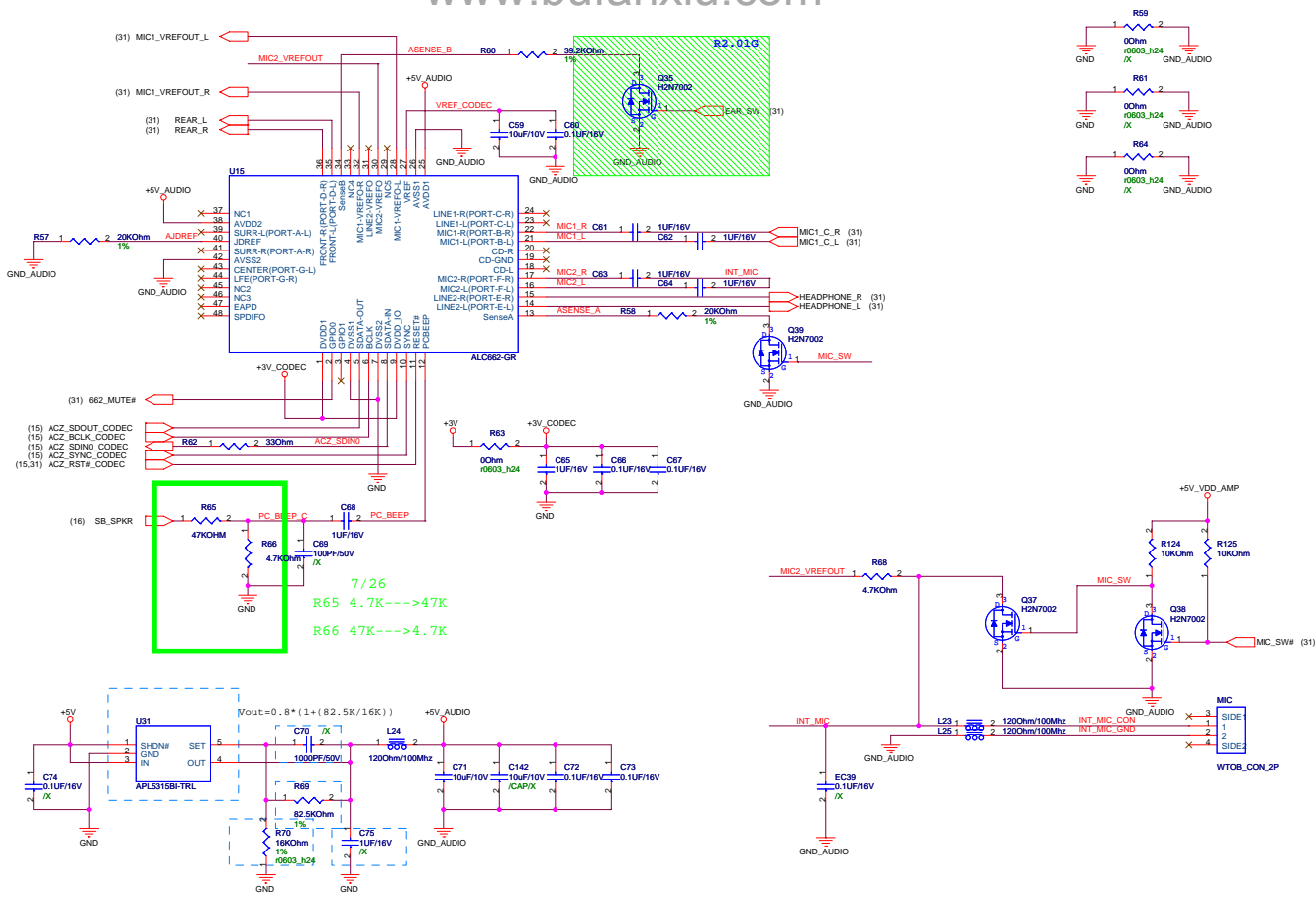

7/26
 R65 4.7K--->47K
 R66 47K--->4.7K

<Variant Name>

| | | |
|---------------------------|--------------|-----------------------------|
| ASUS | | Title : Codec_ALC662 |
| ASUSTEK COMPUTER INC. NBI | | Engineer: Kell_Huang |
| Size | Project Name | Rev |
| A3 | P700 | R2.3G |
| Date: 11/13/2007 | Sheet | 30 of 48 |

| GAIN1 | GAIN0 | Gain |
|-------|-------|--------|
| 0 | 0 | 6db |
| 0 | 1 | 10db |
| 1 | 0 | 15.6db |
| 1 | 1 | 21.6db |

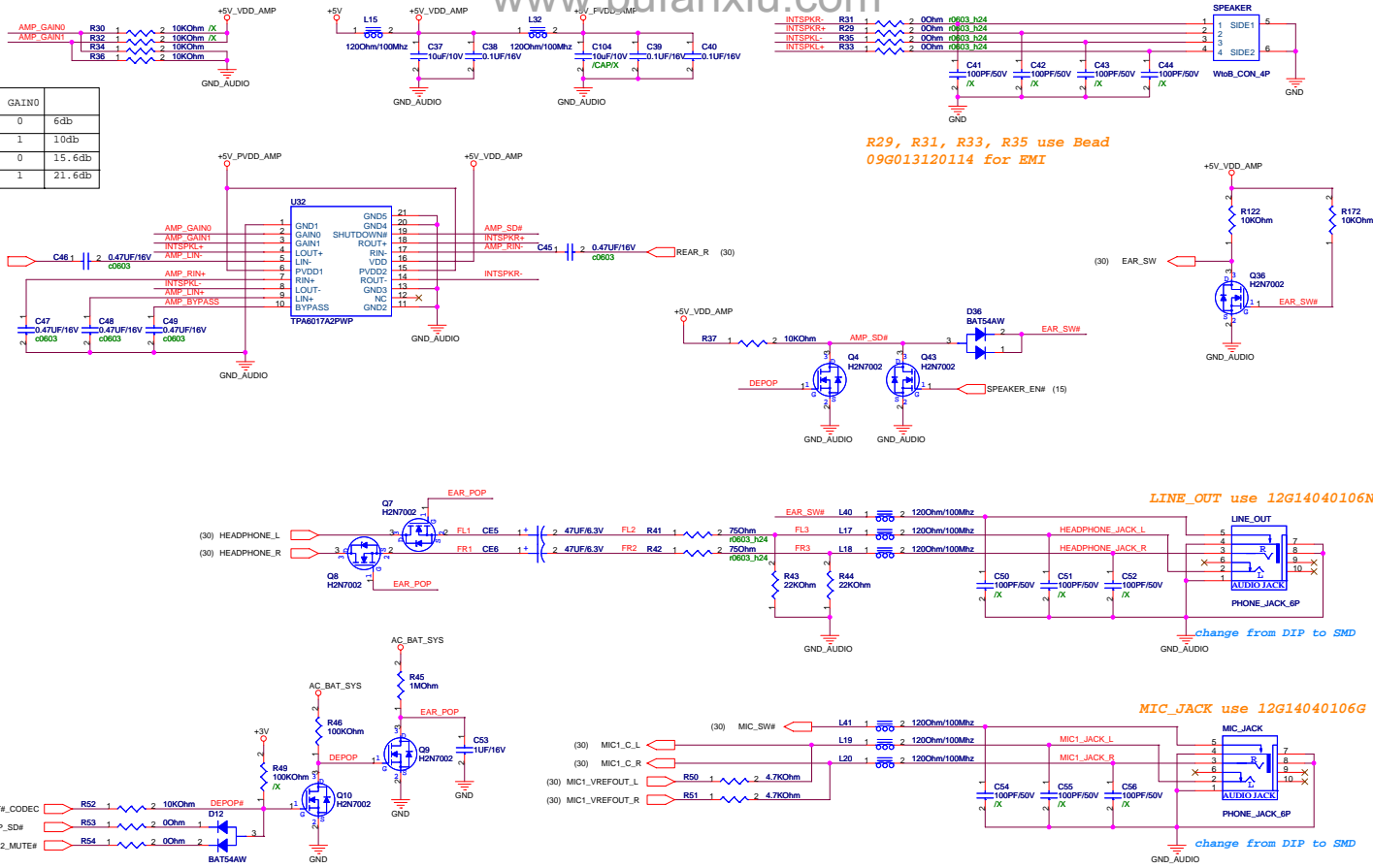

R29, R31, R33, R35 use Bead 09G013120114 for EMI

LINE_OUT use 12G14040106N

MIC JACK use 12G14040106G

<Variant Name>

| | | | |
|-----------------------|--------------|-------------------------------|-------|
| ASUS | | Title : Audio_AMP_Jack | |
| ASUSTek Computer INC. | | Engineer: <i>Kell Huang</i> | |
| Size | Project Name | | Rev |
| A3 | P700 | | R2.3G |
| Date: 11/13/2007 | Sheet | 31 | of 48 |

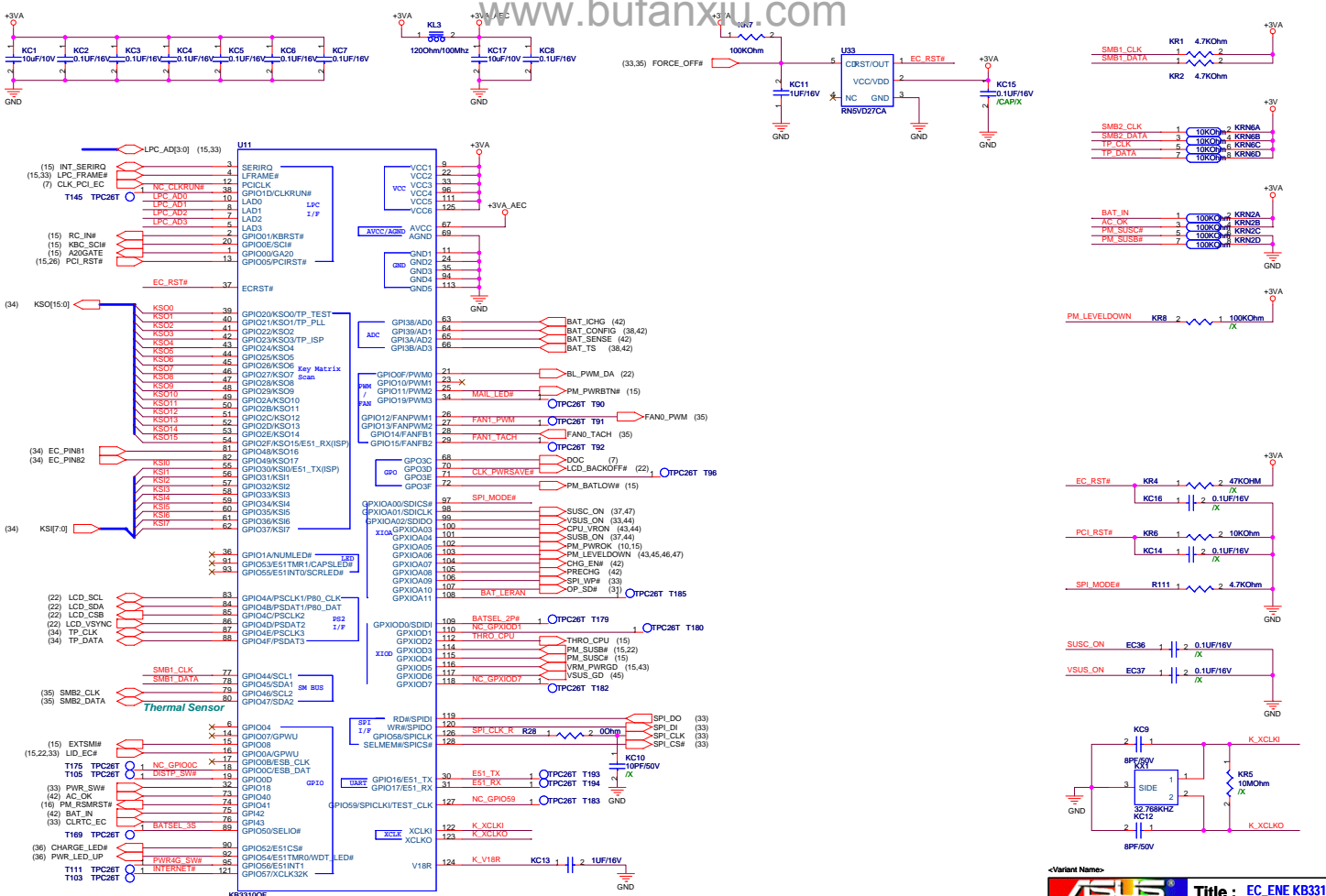

ASUS Title: EC_ENE_K83310
 ASUSTek Computer INC. Engineer: Kell_Huang
 Size: A3 Project Name: P700
 Date: 11/13/2007 Sheet: 32 of 48

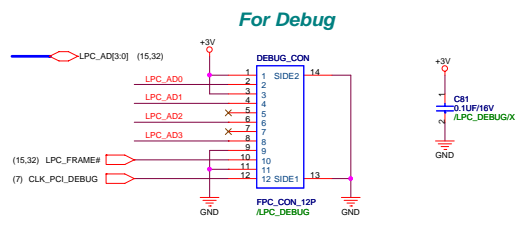
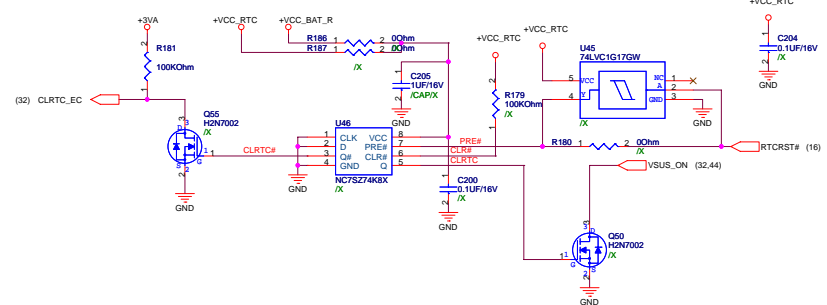
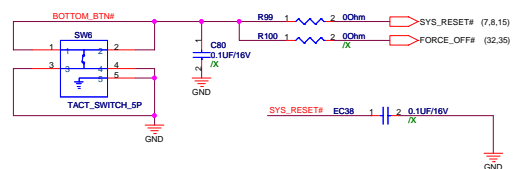
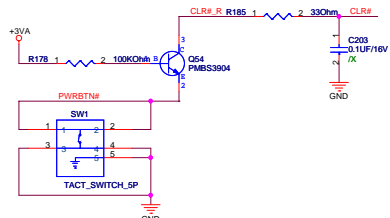
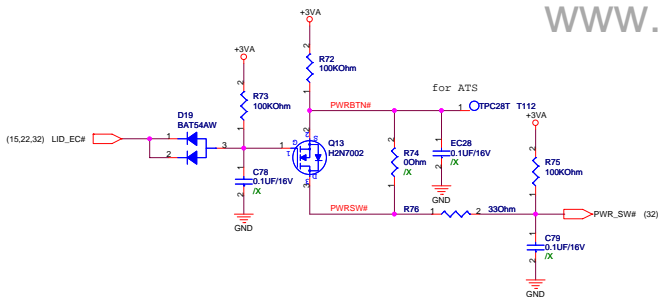

Debug Card cable use Z96 Touch Pad cable, P/N:
 14G124110126, 14G124110120, 14G124110121
 14G124110124, 14G124110125

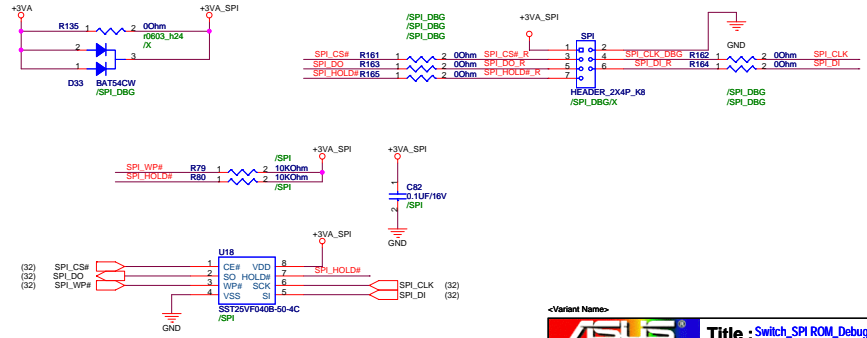

| | | | |
|-----------------------|--------------|------------------------------|-------|
| ASUS | | Title : Switch_SPI_ROM_Debug | |
| ASUSTek Computer INC. | Project Name | Engineer: Kell_Huang | Rev |
| A3 | P700 | | R2.3G |
| Date: 11/13/2007 | Sheet | 33 | of 48 |

For Touch-Pad

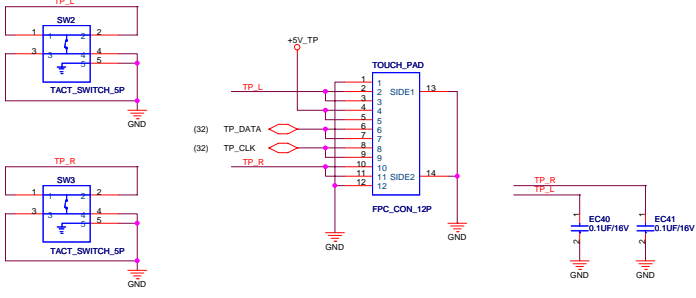

For Keyboard

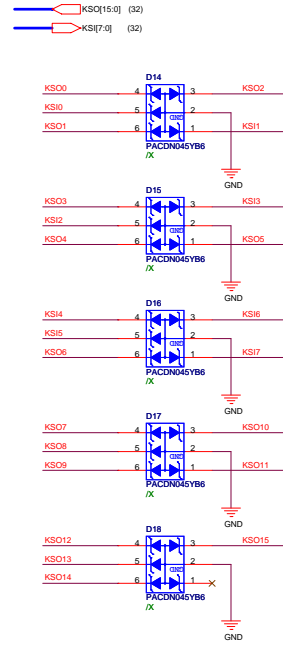
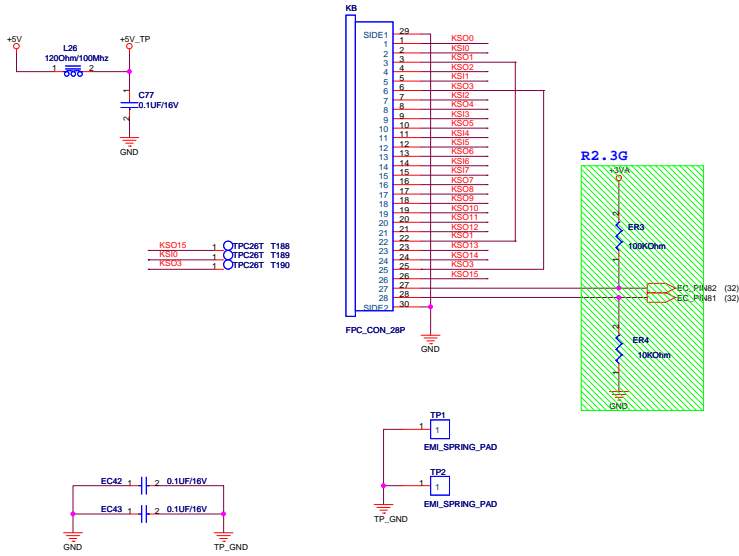

| | | | |
|-----------------------|--------------|----------------------|-------|
| ASUS | | Title : KB_Touch Pad | |
| ASUSTek Computer INC. | | Engineer: Keli_Huang | |
| Size | Project Name | | Rev |
| A3 | P700 | | R2.3G |
| Date: 08-11-14, 2007 | Sheet | 34 | of 48 |

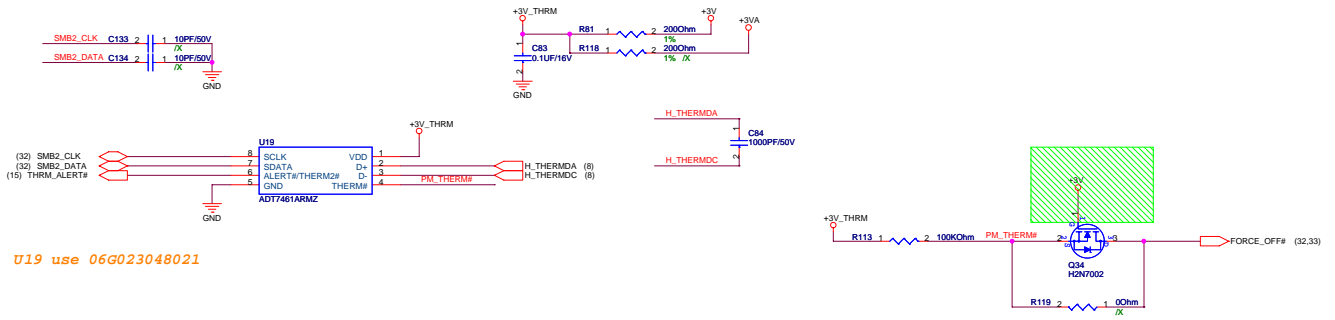

U19 use 06G023048021

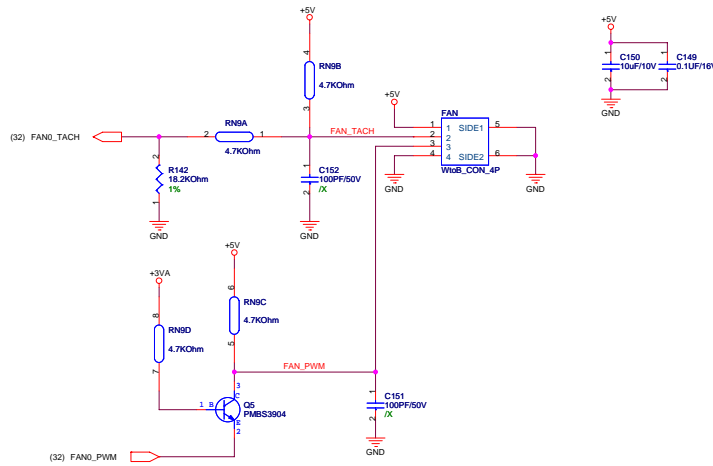

| | | | |
|-----------------------|--------------|----------------------------|----------|
| ASUS | | Title : Thermal Sensor_FAN | |
| ASUSTek Computer INC. | | Engineer: Keli_Huang | |
| Size | Project Name | | Rev |
| A3 | P700 | | R2.3G |
| Date: 11/13/2007 | | Sheet | 35 of 48 |

for POWER LED

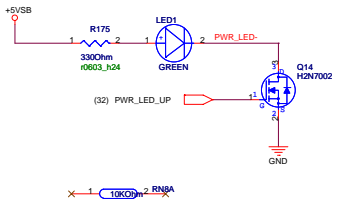

for CHARGE LED

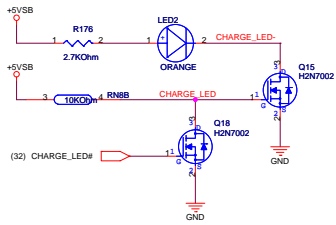

for FLASH LED

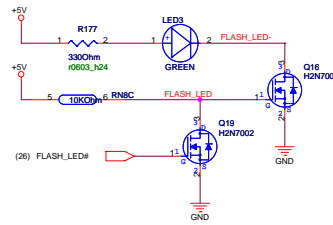

for WLAN LED

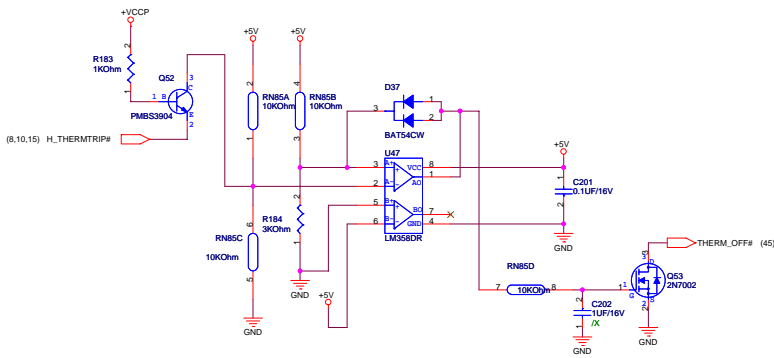
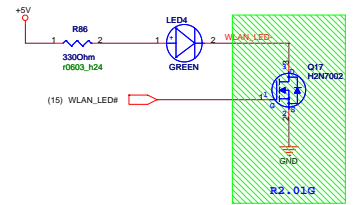

| | | | |
|-----------------------|-------------------|----------------------|--|
| ASUS | | Title : LED | |
| ASUSTek Computer INC. | | Engineer: Keli_Huang | |
| Size A3 | Project Name P700 | Rev R2.3G | |
| Date: 11/13/2007 | Sheet 36 | of 48 | |

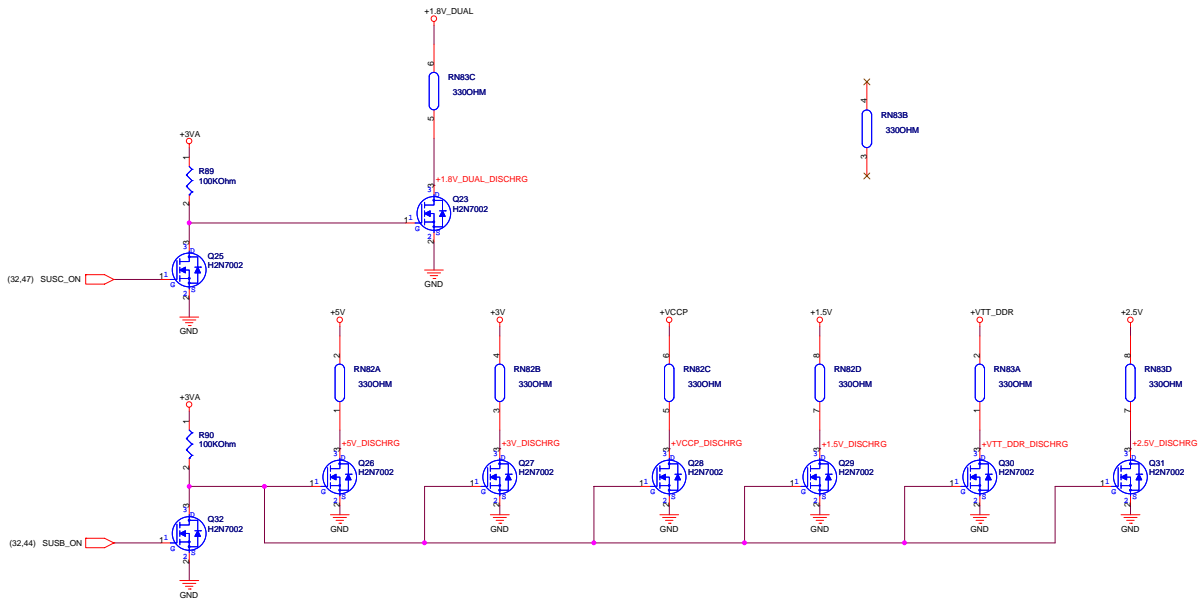

<Variant Name>

| | | | |
|-----------------------|--------------|-----------------------------|-------|
| ASUS | | Title : Discharge | |
| ASUSTek Computer INC. | | Engineer: <i>Kell_Huang</i> | |
| Size | Project Name | | Rev |
| A3 | P700 | | R2.3C |
| Date: 11/13/2007 | | Sheet 37 | of 48 |

DC IN

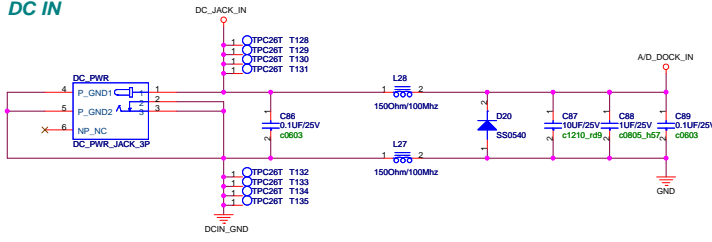

BAT IN

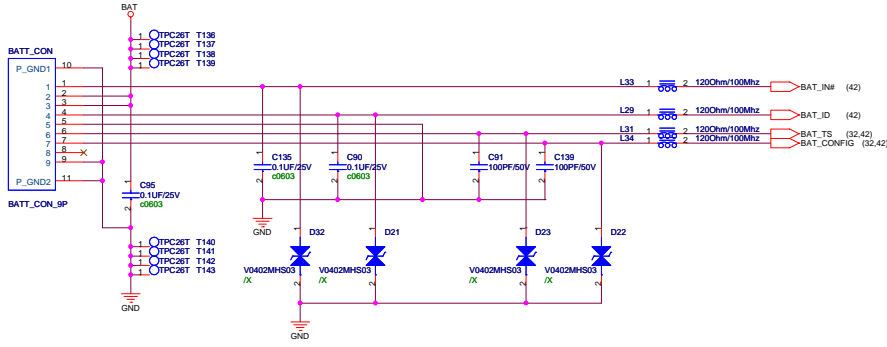

<Variant Name>

| | | | |
|-----------------------|--------------|-----------------------------|----------|
| ASUS | | Title : PWR Jack | |
| ASUSTek Computer INC. | | Engineer: <i>Kail_Huang</i> | |
| Size | Project Name | Rev | |
| AS | P700 | R2 | 82 |
| Date: 2007-08-13 | | Sheet | 38 of 48 |

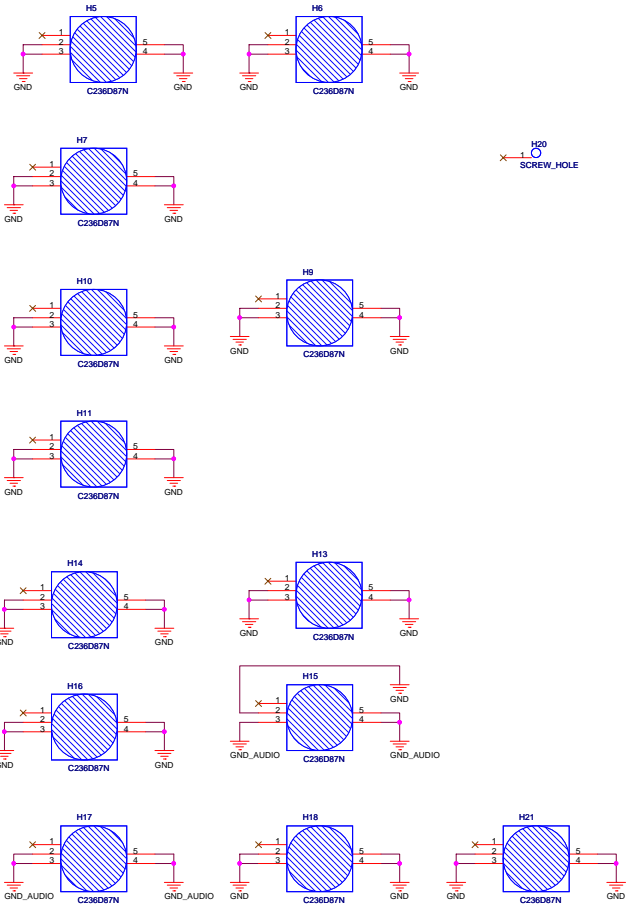

H20
SCREW_HOLE

<Variant Name>

| | | | |
|-----------------------|--------------|----------------------|-------|
| | | Title : Srew Hole | |
| ASUSTek Computer INC. | | Engineer: Keli_Huang | |
| Size | Project Name | | Rev |
| A3 | P700 | | R2.3G |
| Date: 11/11/13, 2007 | | Sheet 39 | of 48 |

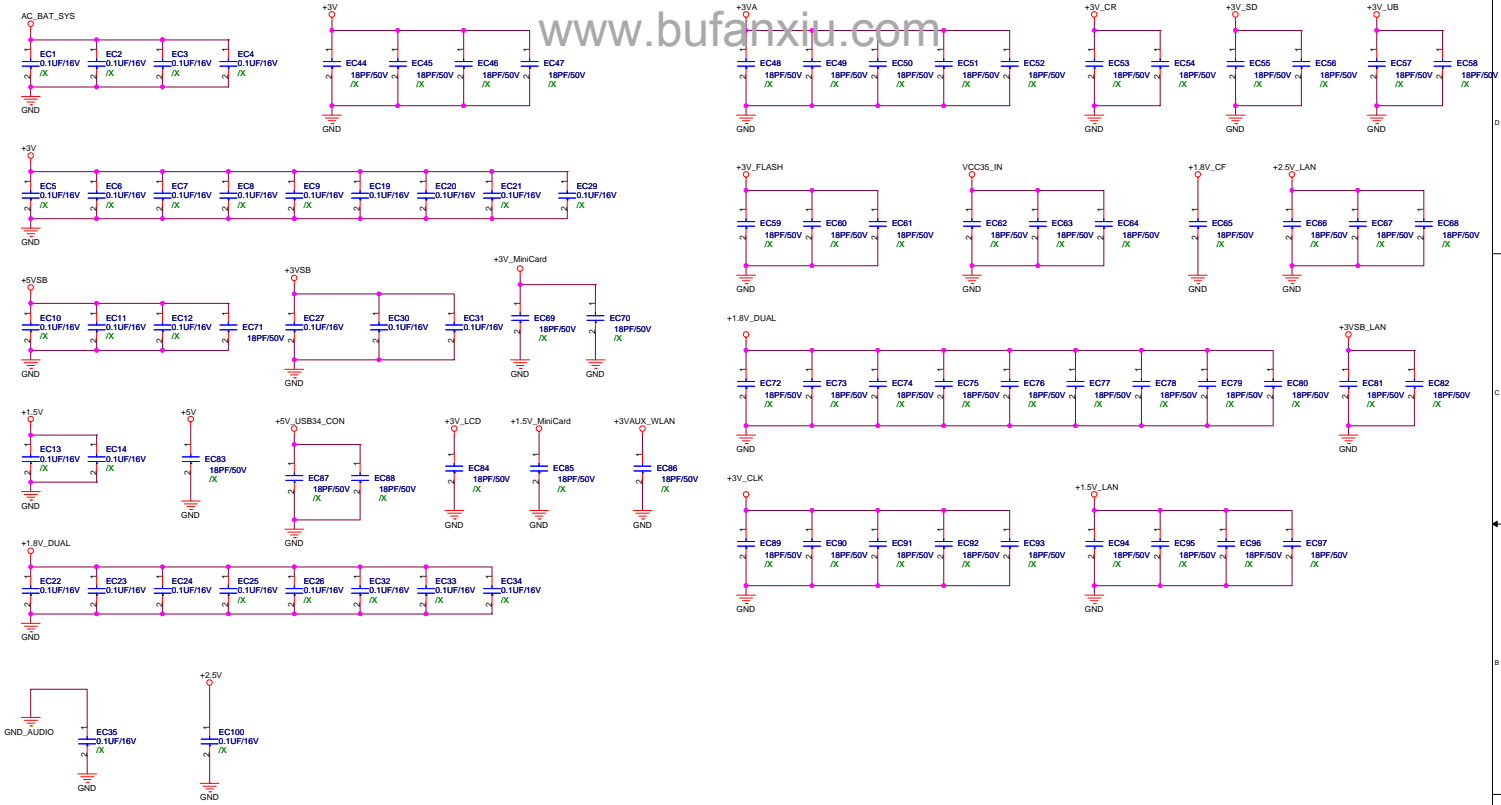

<Variant Name>

| | | |
|-----------------------|-----------------------------|-----------------------------|
| ASUS | | Title : EMI |
| ASUSTek Computer INC. | | Engineer: <i>Kell Huang</i> |
| Size A3 | Project Name P700 | Rev R2.3C |
| Date: 11/13/2007 | Sheet 40 | of 48 |

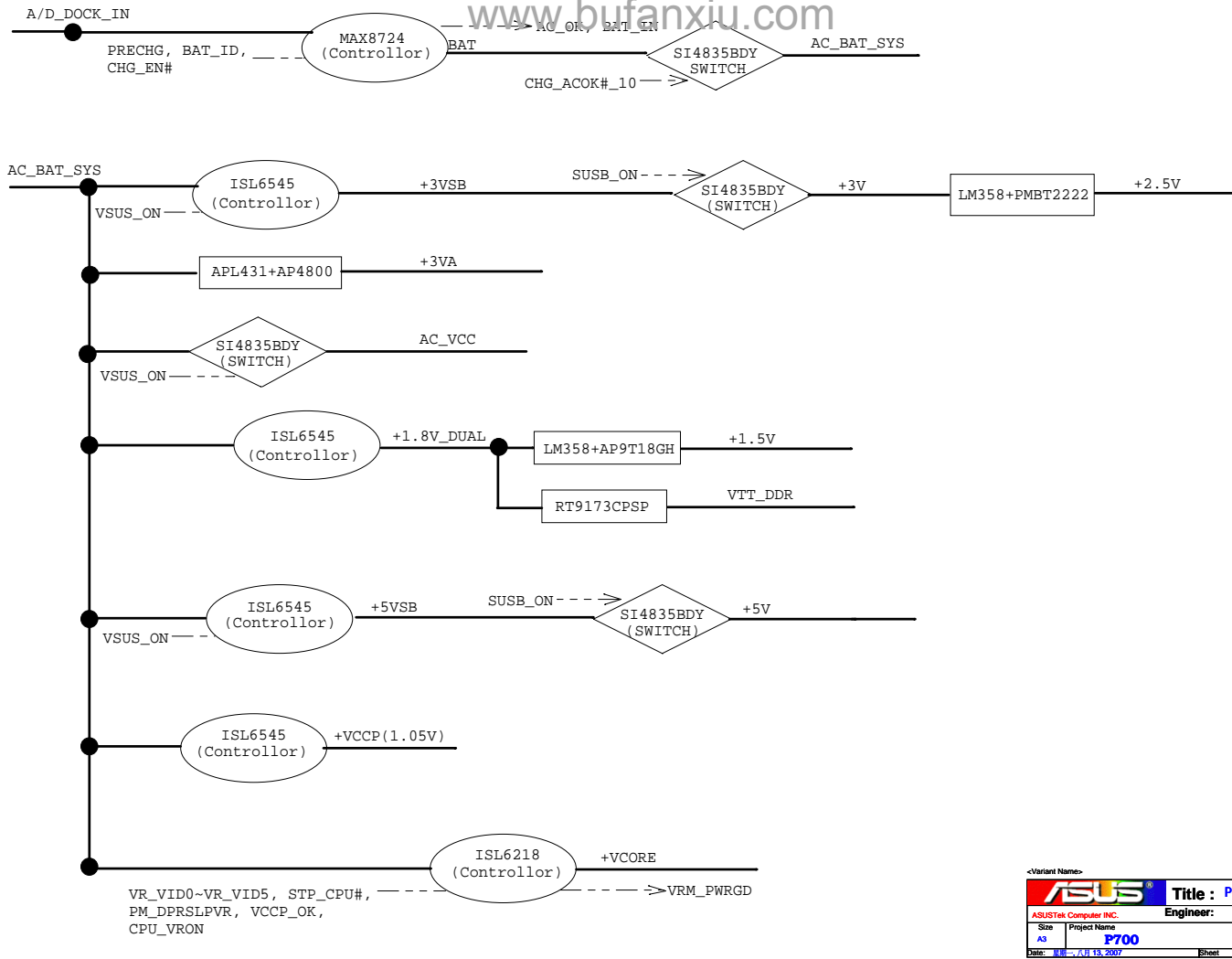

ASUS
ASUSTek Computer INC.
Size: A3
Project Name: P700
Date: 11/13/2007

Title: Power Flow
Engineer: Joy_Zhou
Rev: R2.3G
Sheet: 41 of 48

Adaptor:9.5V/22W/36W

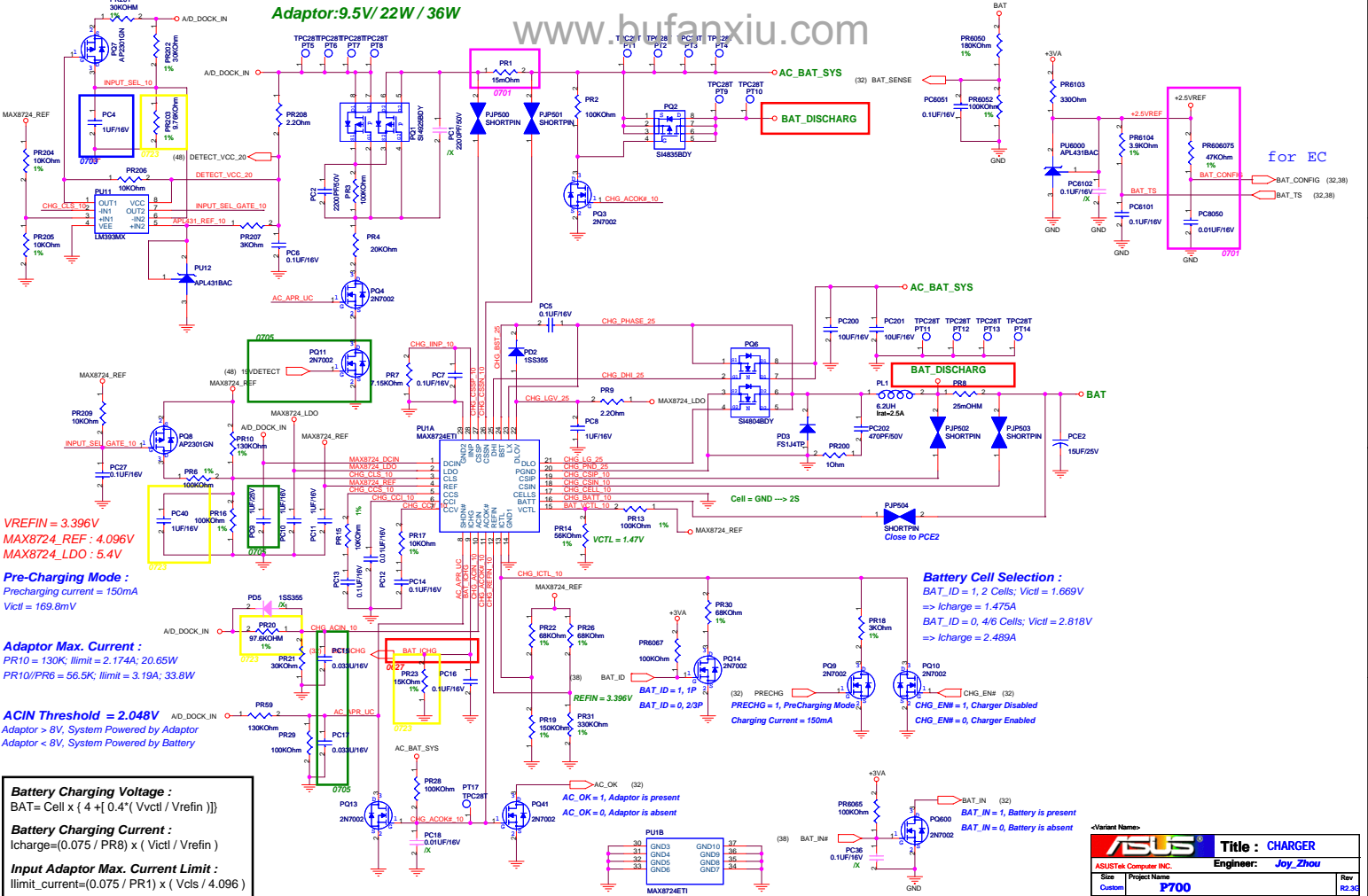

VREFIN = 3.396V
 MAX8724_REF : 4.096V
 MAX8724_LDO : 5.4V

Pre-Charging Mode :
 Precharging current = 150mA
 Vctl = 169.8mV

Adaptor Max. Current :
 PR10 = 130K, Ilimit = 2.174A; 20.65W
 PR10/PR6 = 56.5K, Ilimit = 3.19A; 33.8W

ACIN Threshold = 2.048V
 Adaptor > 8V, System Powered by Adaptor
 Adaptor < 8V, System Powered by Battery

Battery Charging Voltage :
 BAT = Cell x { 4 + [0.4 * (Vctl / Vrefin)] }

Battery Charging Current :
 Icharge = (0.075 / PR8) x (Vctl / Vrefin)

Input Adaptor Max. Current Limit :
 Ilimit_current = (0.075 / PR1) x (Vcls / 4.096)

Battery Cell Selection :
 BAT_ID = 1, 2 Cells; Vctl = 1.669V
 => Icharge = 1.475A

BAT_ID = 0, 4/6 Cells; Vctl = 2.818V
 => Icharge = 2.489A

AC_OK = 1, Adaptor is present
 AC_OK = 0, Adaptor is absent

BAT_IN = 1, Battery is present
 BAT_IN = 0, Battery is absent

| | | | |
|-----------------------|--------------|--------------------|------------|
| ASUS | | Title : CHARGER | |
| ASUSTek Computer INC. | | Engineer: Joy_Zhou | |
| Size | Project Name | Rev | 102-30 |
| Customer | P700 | Date | 11/13/2007 |
| Sheet | 43 | of 48 | |

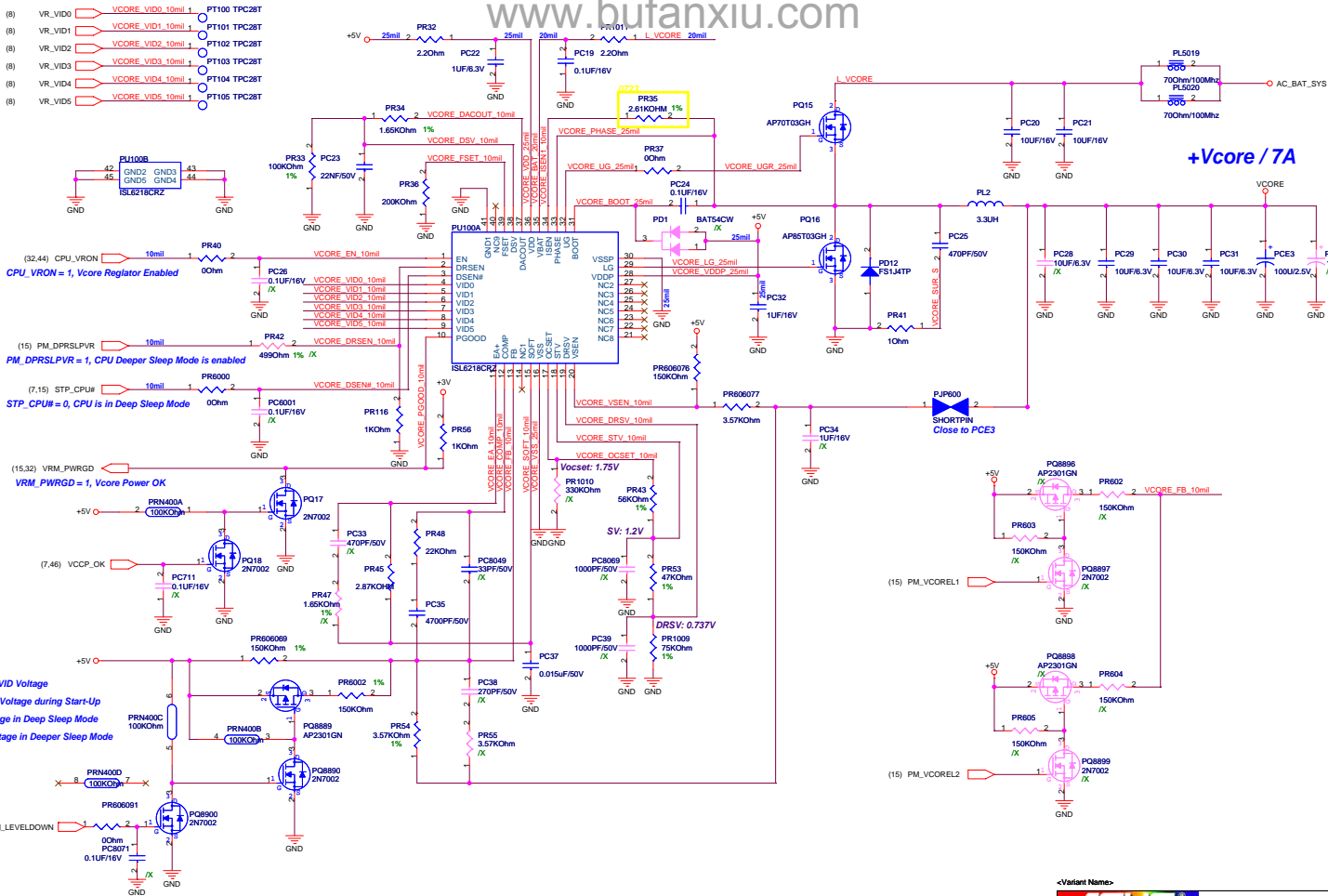

<Variant Name>

| | | |
|-----------------------|---------------------------|---------------------------|
| ASUS | | Title : Vcore(7A) |
| ASUSTek Computer INC. | | Engineer: Joy Zhou |
| Size: A3 | Project Name: P700 | Rev: R2.3C |
| Date: 11/13/2007 | Sheet: 43 | of 48 |

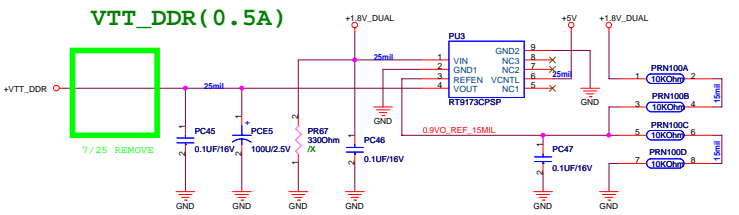
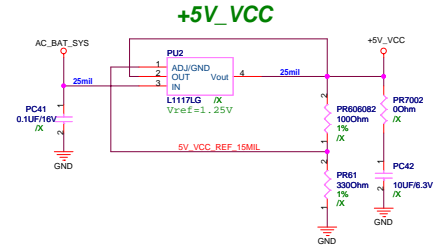
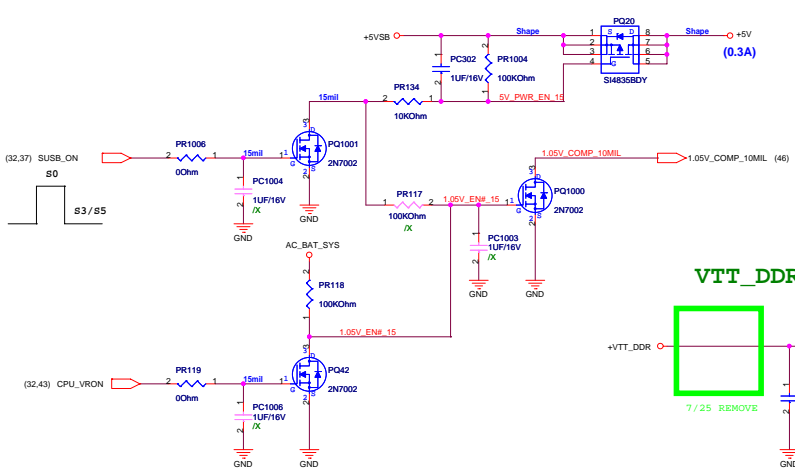
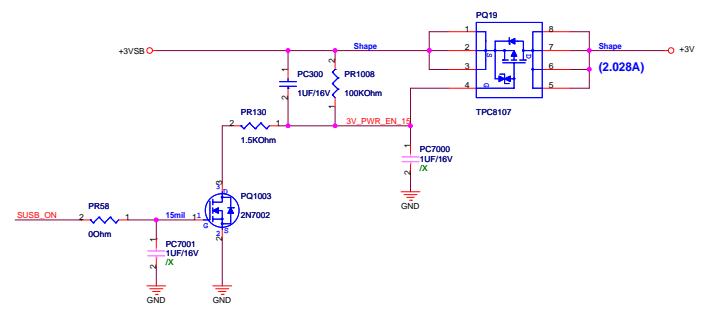
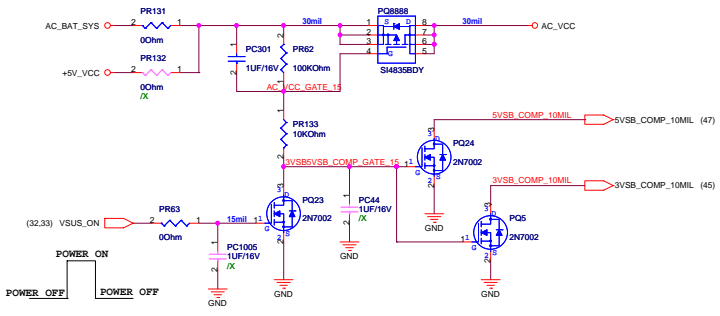

<Variant Name>

| | | | |
|-----------------------|--------------|------------------------------|-------|
| ASUS | | Title : 3V_SV_VTT_DDR | |
| ASUSTek Computer INC. | | Engineer: Joy_Zhou | |
| Size | Project Name | Rev | |
| A3 | P700 | R2.3C | |
| Date: 11/13/2007 | Sheet | 41 | of 48 |

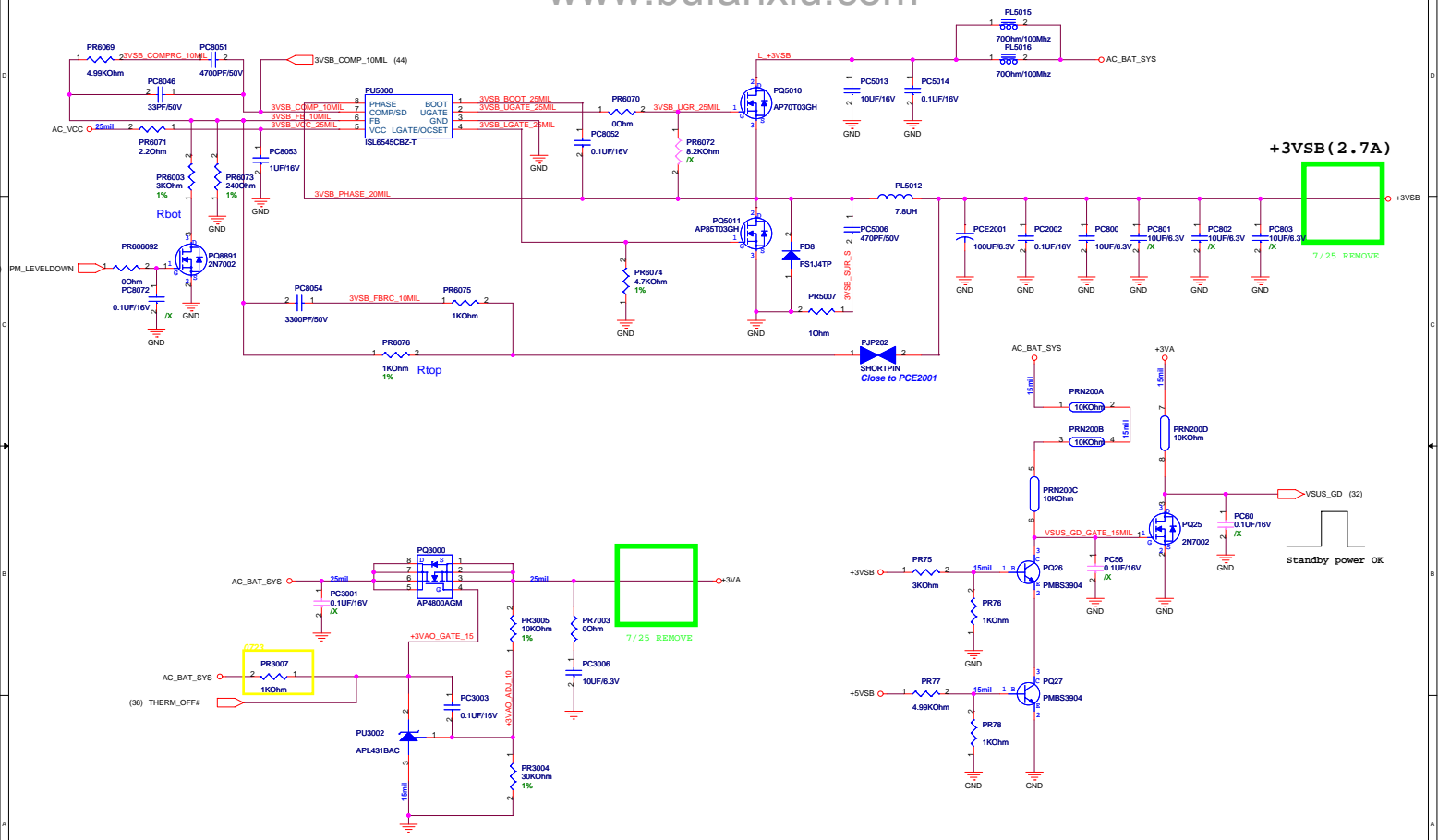

+3V3B (2.7A)

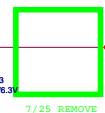

7/25 REMOVE

Standby power OK

<Variant Name>

| | | | |
|-----------------------|---------------------------|---------------------------|--|
| ASUS | | Title : 3VA_3V3B | |
| ASUSTek Computer INC. | | Engineer: Joy_Zhou | |
| Size: A3 | Project Name: P700 | Rev: R2.3C | |
| Date: 11/13/2007 | Sheet: 45 | of: 48 | |

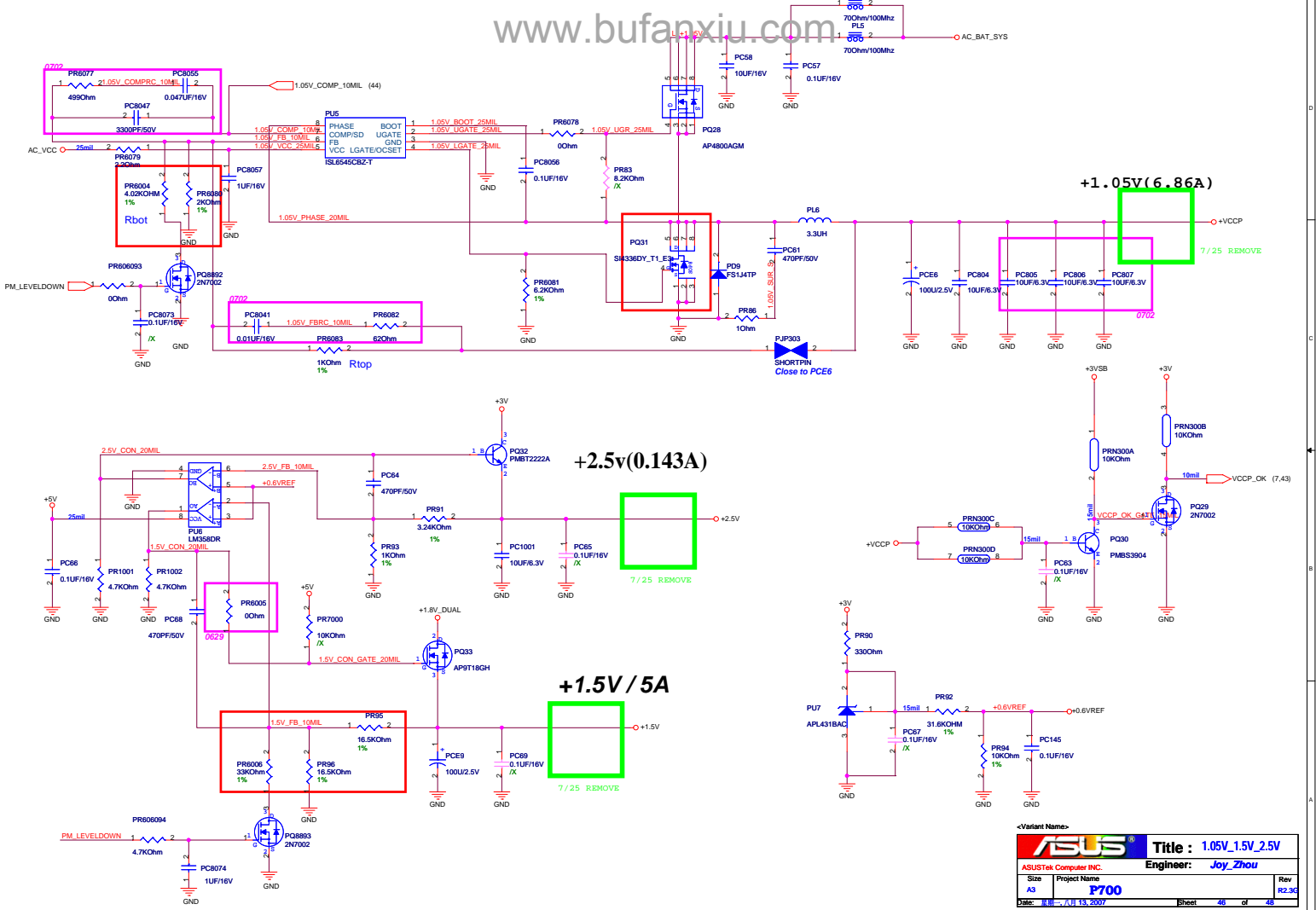

<Variant Name>

| | | | |
|-----------------------|-----------------------------|--------------------------------|--|
| ASUS | | Title : 1.05V_1.5V_2.5V | |
| ASUSTek Computer INC. | | Engineer: Joy_Zhou | |
| Size A3 | Project Name P700 | Rev R2.3C | |
| Date 11/13/2007 | Sheet 48 | of 48 | |

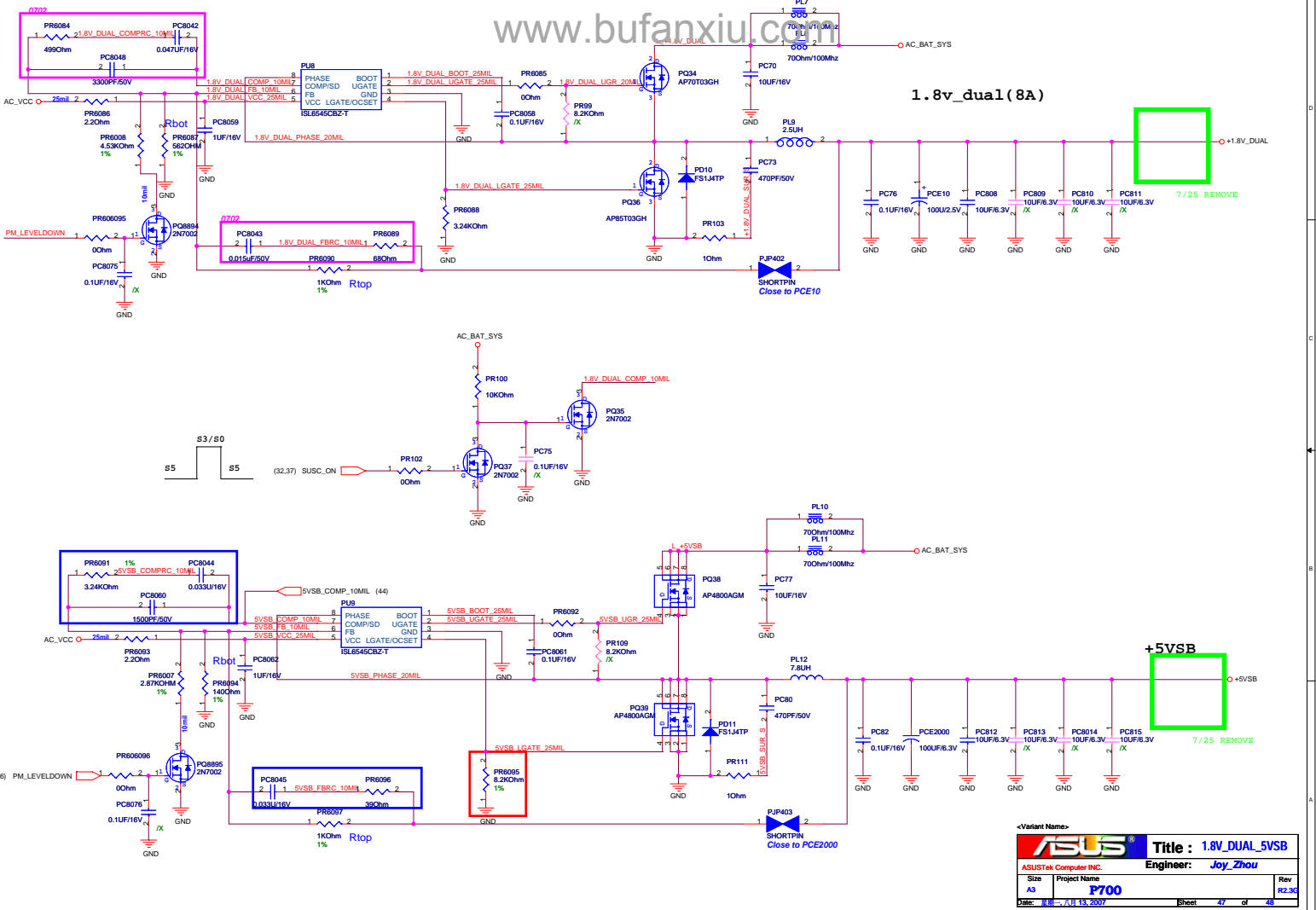

1.8v_dual(8A)

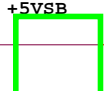

<Variant Name>

| | | |
|-----------------------|---------------------------|-------------------------------|
| ASUS | | Title : 1.8V_DUAL_5VSB |
| ASUSTek Computer INC. | | Engineer: Joy Zhou |
| Size: A3 | Project Name: P700 | Rev: R2.3C |
| Date: 11/13/2007 | Sheet: 47 | of 48 |

19V Detection Circuit

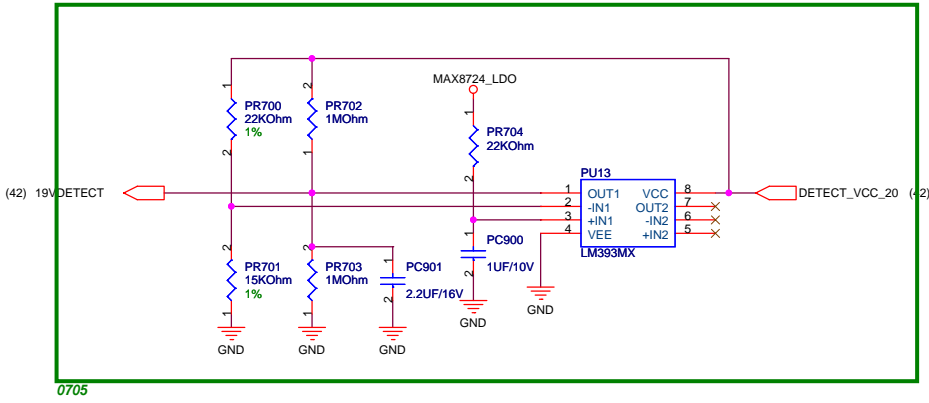

| | | |
|------------------------|-----------------------------|-----------------------------|
| | | Title : 19VDetect |
| ASUSTek COMPUTER Inc. | | Engineer: Carl_Chiou |
| Size A4 | Project Name P700 | Rev R2.3G |
| Date: 星期二, 八月 13, 2007 | | Sheet 48 of 48 |