

- 01\_Block Diagram
- 02\_System Setting
- 03\_CPU-YONAH(HOST)
- 04\_CPU-YONAH(PWR)
- 05\_NB-945GM(HOST)
- 06\_NB-945GM(DMI & CFG)
- 07\_NB-945GM(GRAPHIC)
- 08\_NB-945GM(DDR2)
- 09\_NB-945GM(PWR)
- 10\_NB-945GM(PWR2)
- 11\_NB-945GM(GND)
- 12\_SB-ICH7M(1)
- 13\_SB-ICH7M(2)
- 14\_SB-ICH7M(3)
- 15\_SB-ICH7M(PWR)
- 16\_DDR2 SO-DIMM0
- 17\_DDR2 SO-DIMM1
- 18\_DDR2 TERMINATION
- 19\_CRT
- 20\_LVDS & INVERTER CONNECTOR
- 21\_TV OUT CONN
- 22\_THER SENSOR & FAN
- 23\_CLOCK GEN-ICS954310
- 24\_SWITCH
- 25\_DISCHARGE
- 26\_LAN-RTL8110SCL
- 27\_MDC&RJ45&RJ11
- 28\_MINI CARD
- 29\_CARD1394-R5C832(1)
- 30\_CARD1394-R5C832(2)
- 31\_4 in 1 CARD READER
- 32\_NEWCARD
- 33\_CODEC-ALC882
- 34\_AUDIO AMP & JCAK
- 35\_EC-IT8510E
- 36\_Touch Pad & KB
- 37\_USB CONN
- 38\_ISA ROM
- 39\_LED
- 40\_DC & BAT IN
- 41\_Debug CONN.
- 42\_SATA-HDD & ODD & E-SATA
- 43\_SREW HOLE
- 44\_TPM
- 45\_BT
- 46\_POWER\_FLOWCHART
- 47\_POWER\_CHARGER
- 48\_POWER\_SYSTEM\_+3VO & +5VO
- 49\_POWER\_VCORE
- 50\_POWER\_I/O\_DDR & VTT
- 51\_POWER\_I/O\_1.5VS & 1.15VS
- 52\_POWER\_I/O\_+3VAO & +2.5VS
- 53\_POWER\_LOAD SWITCH
- 54\_POWER\_GOOD\_DETECTOR
- 55\_POWER\_SIGNAL
- 56\_History
- 57\_Power Sequence

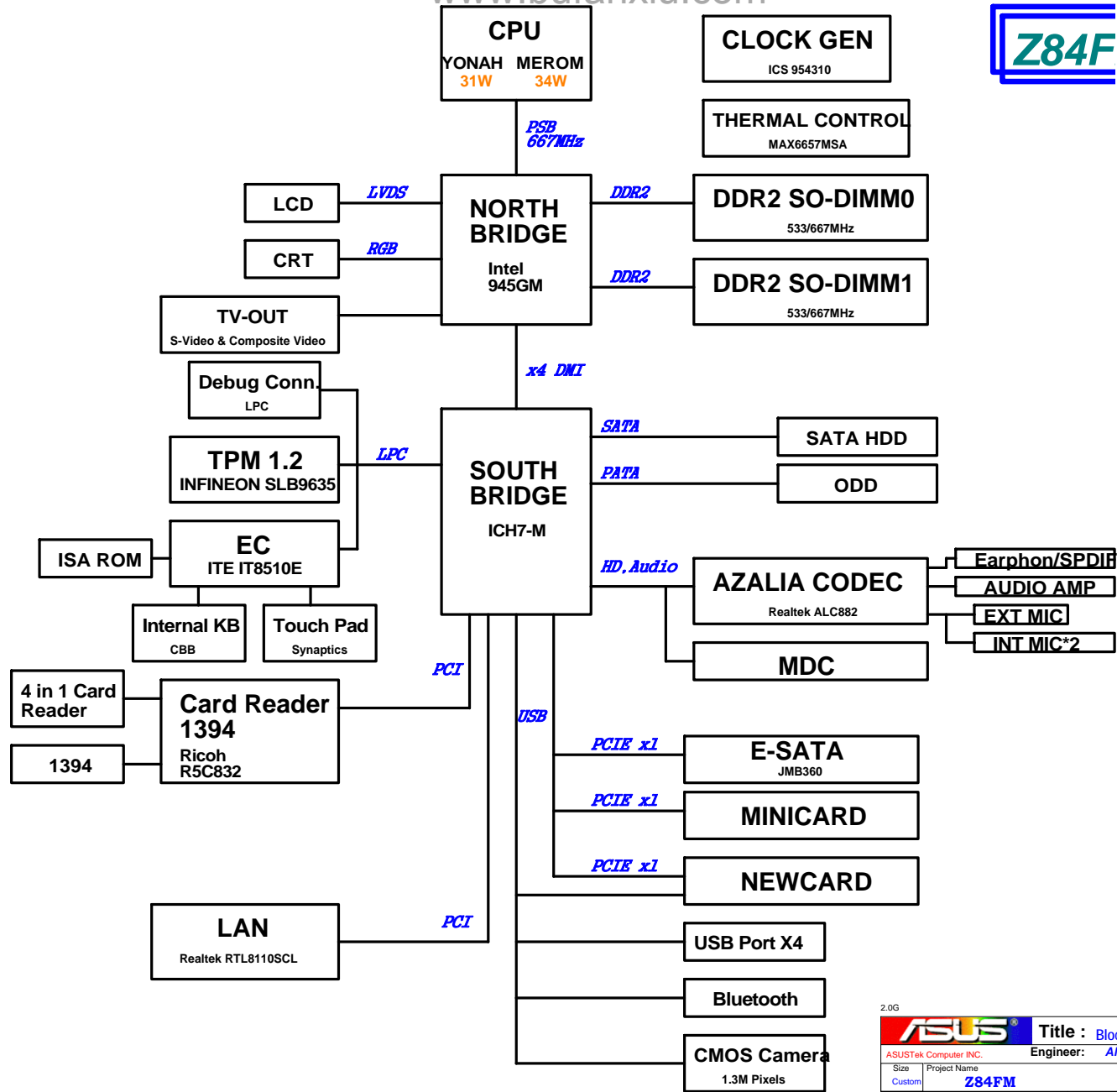

2.0G

<b>ASUS</b>		Title : Block Diagram	
ASUSTek Computer INC.		Engineer: Alan Chen	
Size	Project Name	Rev	
Custom	Z84FM	2.0	
Date: Thursday, October 05, 2006		Sheet	1 of 57

**EC GPIO SETTING**

Pin	Pin Name	Signal Name	Type
32	PWM0/GPA0	BL_PWM_DA	O
33	PWM1/GPA1	FAN_PWM	O
36	PWM2/GPA2	CLK_PWRSERVE#	O
37	PWM3/GPA3	/	
38	PWM4/GPA4	CHG_LED_UP#	O
39	PWM5/GPA5	PWR_LED_UP#	O
40	PWM6/GPA6	/	
43	PWM7/GPA7	LCD_BACKOFF#	O
153	RXD/GPB0	NUM_LED	O
154	TXD/GPB1	CAP_LED	O
162	GPB2	SCR_L_LED	O
163	SMCLK0/GPB3	SMB0_CLK	I/O
164	SMDAT0/GPB4	SMB0_DAT	I/O
5	GA20/GPB5	A20GATE	O
6	KBRST#/GPB6	RC_IN#	O
165	GPB7	/	
47	CLKOUT/GPC0	/	
169	SMCLK1/GPC1	SMB1_CLK	I/O
170	SMDAT1/GPC2	SMB1_DAT	I/O
171	GPC3	Mail_LED	O
172	TMR10/WUI2/GPC4	AC_OK#	I
175	GPC5	OP_SD#	O
176	TMR11/WUI3/GPC6	BAT_IN_OC#	I
1	CK32KOUT/GPC7	/	
26	R11#/WUI0/GPD0	SUSB#	I
29	R12#/WUI1/GPD1	SUSC#	I
30	LPCRST#/WUI4/GPD2	PLT_RST#	I
31	ECSC#GPD3	EXT_SC#	O
41	GPD4	/	
42	GINT/GPD5	/	
62	TACH0/GPD6	FAN0_TACH	I
63	TACH1/GPD7	/	
87	ADC4/GPE0	EMAIL_SW#	I
88	ADC5/GPE1	INTERNET#	I
89	ADC6/GPE2	PWR4G_SW#	I
90	ADC7/GPE3	DISTP_SW#	I
2	PWRSW/GPE4	PWR_SW#	I
44	WUI5/GPE5	/	
24	LPCPD#/WUI6/GPE6	LID_EC#	I
25	CLKRUN#/WUI7/GPE7	/	
110	PS2CLK0/GPF0	/	
111	PS2DAT0/GPF1	/	
114	PS2CLK1/GPF2	/	
115	PS2DAT1/GPF3	/	
116	PS2CLK2/GPF4	TP_CLK	I/O
117	PS2DAT2/GPF5	TP_DAT	I/O
118	PS2CLK3/GPF6	/	
119	PS2DAT3/GPF7	/	
113	FA16/GPG0	FA16	O
112	FA17/GPG1	FA17	O
104	FA18/GPG2	FA18	O
103	FA19/GPG3	/	
3	FA20/GPG4	THRM_CPU#	I
4	FA21/GPG5	/	
27	LPC80HL/GPG6	PMTHERM#	O
28	LPC80LL/GPG7	AC_APR_UC#	I

Pin	Pin Name	Signal Name	Type
48	GPH0	VSUS_ON	O
54	GPH1	VSUS_GD#	I
55	GPH2	CPUPWR_GD#	I
69	GPH3	PM_PWRBTN#	O
70	GPH4	SUSC_ON	O
75	GPH5	SUSB_ON	O
76	GPH6	CPU_VRON	O
105	GPH7	PM_RSMRST#	O
148	GPI0	ICHT7_PWROK	O
149	GPI1	/	
152	GPI2	MCHOK	I
155	GPI3	CHG_EN#	O
156	GPI4	PRECHG	O
168	GPI5	BAT_LL#	O
174	GPI6	BAT_LEARN	O

**ICH7-M GPIO SETTING**

Pin	Pin Name	Signal Name	Type	Power Well	Default
AB18	GPI000/BM_BUSY#	PM_BMBUSY#	I	Core(To:3.3V)	GPI
C8	GPI001/REQ5#	PCI_REQ#5	I/O	Core(To:5V)	GPI
G8	GPI002/PIRQE#	PCI_INTE#	I(OD)	Core(To:5V)	GPI
F7	GPI003/PIRQF#	PCI_INTF#	I(OD)	Core(To:5V)	GPI
F8	GPI004/PIRQG#	PCI_INTG#	I(OD)	Core(To:5V)	GPI
G7	GPI005/PIRQH#	PCI_INTH#	I(OD)	Core(To:5V)	GPI
AC21	GPI006	NC	I/O	Core(To:3.3V)	GPI
AC18	GPI007	WLAN_BT_LED_EN#	I	Core(To:3.3V)	GPI
E21	GPI008	EXTSM#	I	SUS(To:3.3V)	GPI
E20	GPI009	SATA_DET#0	I/O	SUS(To:3.3V)	GPI
A20	GPI010	WLAN_ON#	O	SUS(To:3.3V)	GPI
B23	SMBALERT#/GPI011	SMB_ALERT#	I/O	SUS(To:3.3V)	Native
F19	GPI012	KBC_SC#	I	SUS(To:3.3V)	GPI
E19	GPI013	TP	I/O	SUS(To:3.3V)	GPI
R4	GPI014	NC	I/O	SUS(To:3.3V)	GPI
E22	GPI015	CB_SD#	I/O	SUS(To:3.3V)	GPI
AC22	GPI016	PM DPRSLPVR	O	Core(To:3.3V)	Native
D8	GPI017/GNT5#	PCI_GNT#5	I/O	Core(To:3.3V)	GPO
AC20	GPI018/STP_PC#	STP_PC#	O	Core(To:3.3V)	GPO
AH18	GPI019/SATA1GP	NC	O	Core(To:3.3V)	GPI
AF21	GPI020/STP_CPU#	STP_CPU#	O	Core(To:3.3V)	GPO
AE19	GPI021/SATA0GP	NC	I/O	Core(To:3.3V)	GPI
A13	GPI022/REQ4#	PCI_REQ#4	I/O	Core(To:3.3V)	Native
AA5	LDRQ1#/GPI023	TP	I/O	Core(To:3.3V)	Native
R3	GPI024	NC	I/O	SUS(To:3.3V)	GPO
D20	GPI025	NC	I/O	SUS(To:3.3V)	GPO
A21	GPI026/EL_RSVD	NC	I/O	SUS(To:3.3V)	GPO
B21	GPI027/EL_STATE0	PD_DET#	I/O	SUS(To:3.3V)	GPO
E23	GPI028/EL_STATE1	NC	I/O	SUS(To:3.3V)	GPO
C3	GPI029/OC#5	USB_OC#5	I/O	SUS(To:3.3V)	Native
A2	GPI030/OC#6	NEWCARD_OC#	I	SUS(To:3.3V)	Native
B3	GPI031/OC#7	USB_OC#7	I/O	SUS(To:3.3V)	Native
AG18	GPI032/CLKRUN#	PM_CLKRUN#	O	Core(To:3.3V)	GPO
AC19	GPI033/AZ_DOCK_EN#	BT_ON#	O	Core(To:3.3V)	GPO
U2	GPI034/AZ_DOCK_RST#	NC	I/O	Core(To:3.3V)	GPO
AD21	GPI035	NC	I/O	Core(To:3.3V)	GPO
AH19	GPI036/SATA2GP	NC	I/O	Core(To:3.3V)	GPI
AE19	GPI037/SATA3GP	PCB_ID0	I	Core(To:3.3V)	GPI
AD20	GPI038	PCB_ID1	I	Core(To:3.3V)	GPI
AE20	GPI039	PCB_ID2	I	Core(To:3.3V)	GPI
A14	GNT4#/GPI048	PCI_GNT#4	I/O	Core(To:3.3V)	Native
AG24	GPI049/CPUPWRGD	H_PWRGD	I	V_CPU_IO	Native

PCI Device	IDSEL#	REQ/GNT#	Int
CARD READER	AD17	0	INT
1394	AD17	0	INT
LAN	AD16	2	INT

SM-Bus Device	SM-Bus Address
Clock Generator	1101001x (D2)
SO-DIMM 0	1010000x (A0)
SO-DIMM 1	1010001x (A2)
Thermal Sensor	0101110x (5C)



2.0G

<b>ASUS</b>		Title : <Title>	
ASUSTek Computer INC.		Engineer: Alan Chen	
Size	Project Name	Rev	
Custom	<b>Z84FM</b>	2.0	
Date: Thursday, October 05, 2006		Sheet 2 of 57	



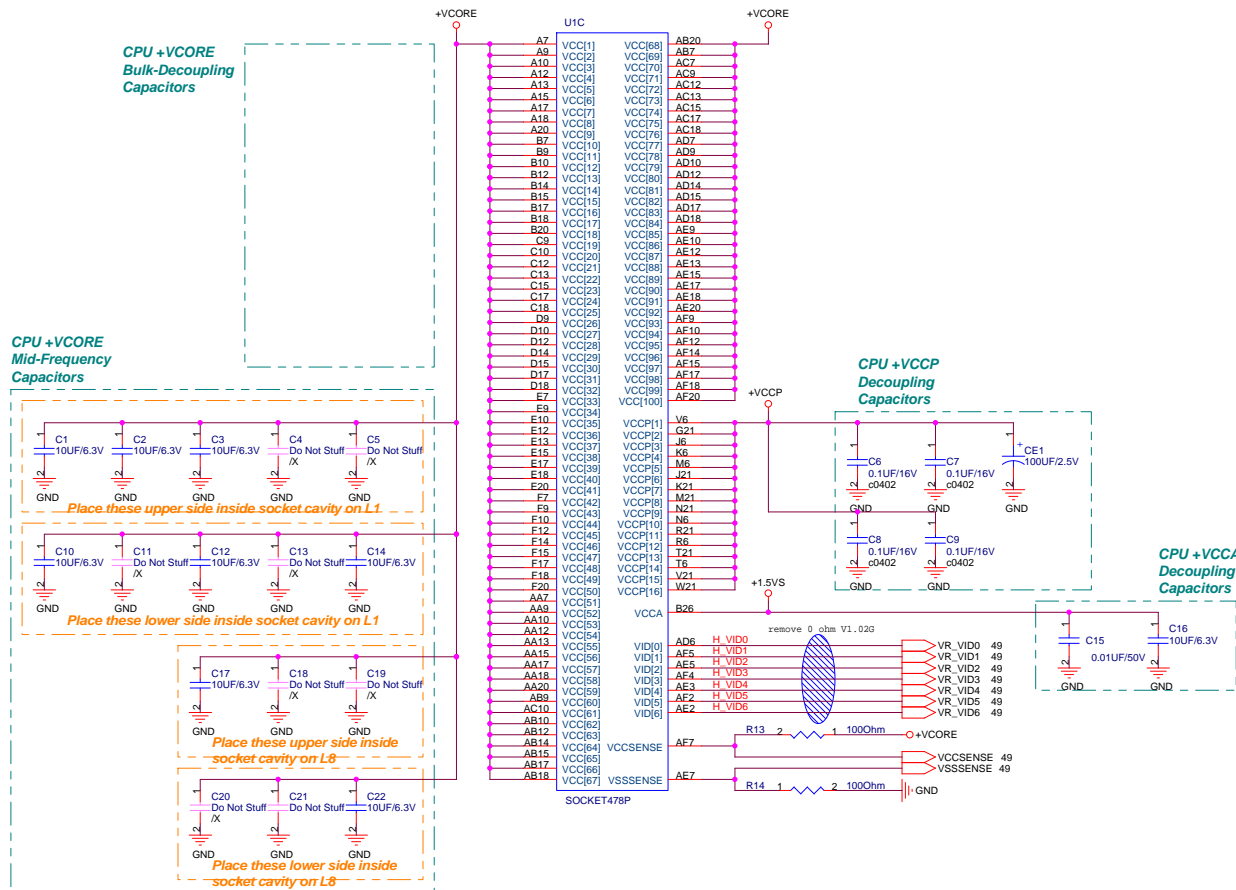

UID		
A4	VSS[11]	P6
A8	VSS[12]	P21
A11	VSS[3]	P24
A14	VSS[85]	R2
A16	VSS[5]	R5
A19	VSS[6]	R22
A23	VSS[7]	R25
A26	VSS[8]	T1
B6	VSS[9]	T4
B8	VSS[9]	T23
B11	VSS[10]	T26
B13	VSS[12]	U3
B16	VSS[13]	U6
B19	VSS[14]	U21
B21	VSS[15]	U24
B24	VSS[16]	V2
C5	VSS[17]	V5
C8	VSS[17]	V22
V5	VSS[18]	V5
C11	VSS[19]	V25
C14	VSS[21]	W1
C16	VSS[20]	W4
C19	VSS[22]	W3
C2	VSS[23]	W26
C22	VSS[24]	Y3
C25	VSS[25]	Y6
D1	VSS[26]	Y21
D4	VSS[27]	Y24
D8	VSS[28]	AA2
D11	VSS[29]	AA5
D13	VSS[31]	AA8
D16	VSS[30]	AA11
D19	VSS[32]	AA14
D23	VSS[33]	AA16
D26	VSS[34]	AA19
E3	VSS[35]	AA22
EB	VSS[36]	AA25
E11	VSS[37]	AB1
E14	VSS[38]	AB4
E17	VSS[39]	AB8
E19	VSS[40]	AB11
E21	VSS[42]	AB16
E24	VSS[43]	AB19
F5	VSS[44]	AB23
F8	VSS[45]	AB26
F11	VSS[46]	AC3
F13	VSS[47]	AC6
F16	VSS[48]	AC8
F19	VSS[49]	AC11
F2	VSS[50]	AC14
F22	VSS[51]	AC16
F25	VSS[52]	AC19
G4	VSS[53]	AC21
G1	VSS[54]	AC24
G23	VSS[55]	AD2
G26	VSS[56]	AD5
H3	VSS[57]	AD8
H6	VSS[57]	AD11
H21	VSS[58]	AD13
H24	VSS[59]	AD16
J2	VSS[60]	AD19
J5	VSS[62]	AD22
J22	VSS[63]	AD25
K1	VSS[64]	AE1
K4	VSS[66]	AE4
K23	VSS[67]	AE11
K26	VSS[67]	AE14
L3	VSS[69]	AE16
L6	VSS[70]	AE19
L21	VSS[71]	AE23
L24	VSS[72]	AE26
M2	VSS[73]	AE3
M5	VSS[74]	AE6
M22	VSS[76]	AE8
M25	VSS[76]	AE11
N1	VSS[77]	AE13
N4	VSS[77]	AE16
N23	VSS[78]	AE19
N26	VSS[79]	AE21
P3	VSS[80]	AE24
VSS[81]	VSS[162]	

2.0G

**ASUS** Title: CPU\_YONAH(PWR)  
ASUSTeK COMPUTER INC. NB1 Engineer: Alan Chen

Size: Project Name  
Custom: **Z84FM** Rev: 2.0

Date: Thursday, October 05, 2006 Sheet: 4 of 57

RCOMP

For Calibrating the FSB IO Buffer

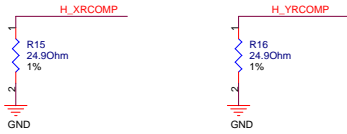

SCOMP

For Slew Rate Compensation on the FSB



Voltage Swing

For Providing a Reference Voltage to The FSB RCOMP circuits

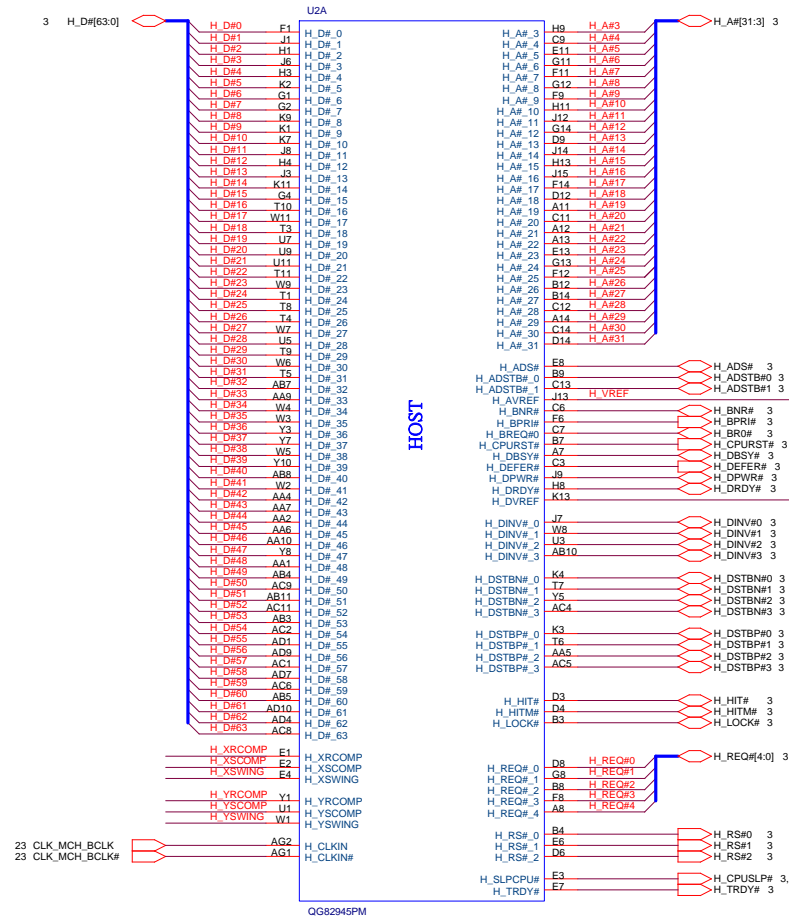
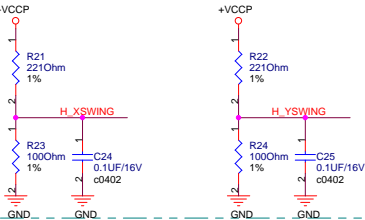

AGTL+ I/O Voltage Reference

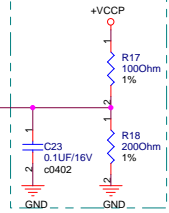

2.0G

ASUS Title : NB-945GM(HOST)
ASUSTeK COMPUTER INC. Engineer: Alan Chen
Size Project Name
Custom Z84FM Rev 2.0
Date: Thursday, October 05, 2006 Sheet 5 of 57

GMCH Strapping

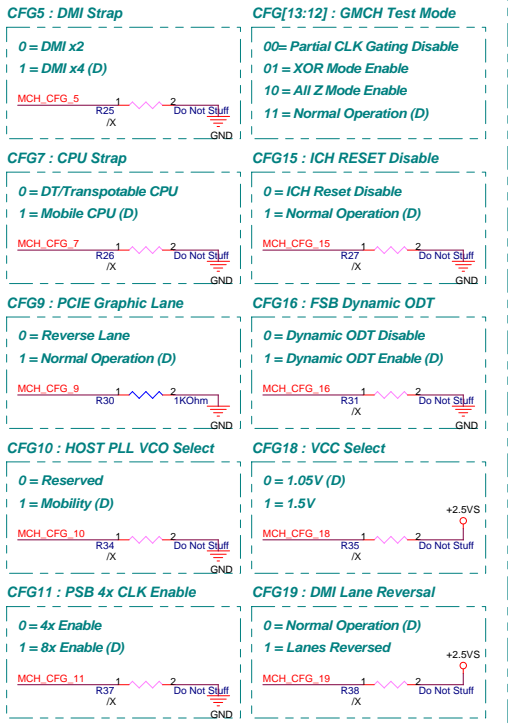

Note: CFG[17:3] have internal pull-up while CFG[20:18] have internal pull-down.

BCLK	FSB	BSEL2	BSEL1	BSEL0
133	533	L	L	H
166	667	L	H	H

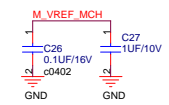
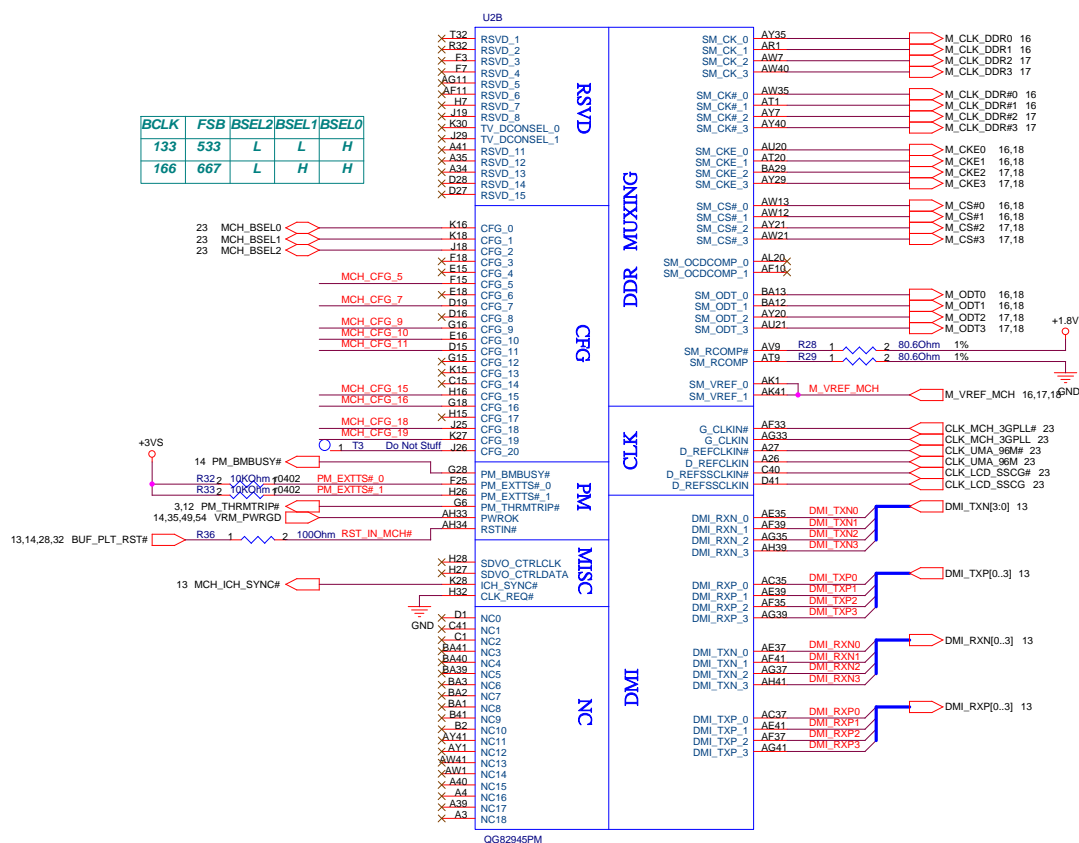

2.0G

**ASUS** Title : NB-945GM(DMI & CFG)

ASUSTeK COMPUTER INC. Engineer: Alan Chen

Size	Project Name	Rev
Custom	<b>Z84FM</b>	2.0

Date: Thursday, October 05, 2006 Sheet 6 of 57

RN39A,B:  
Page 06

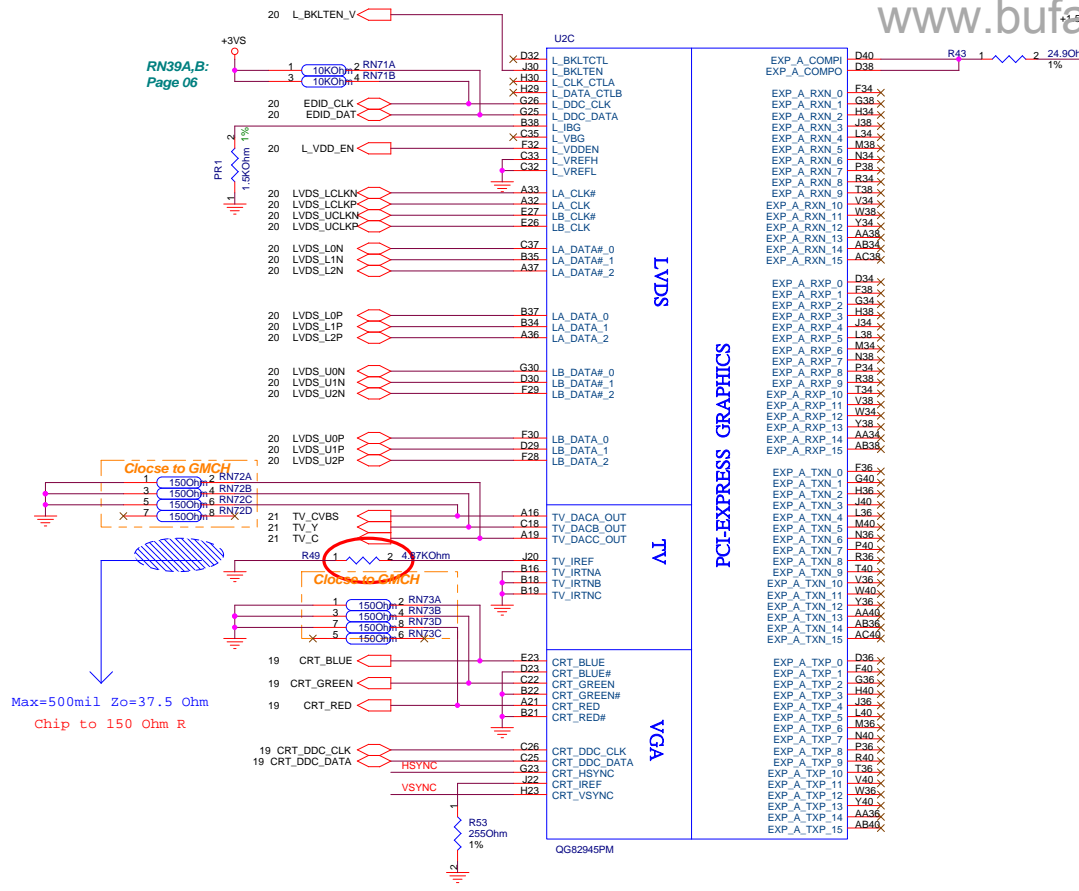

EXP_A_COMP1	D40
EXP_A_COMPO	D38
EXP_A_RXN_0	F34
EXP_A_RXN_1	G38
EXP_A_RXN_2	H34
EXP_A_RXN_3	J38
EXP_A_RXN_4	L34
EXP_A_RXN_5	M34
EXP_A_RXN_6	N34
EXP_A_RXN_7	P38
EXP_A_RXN_8	R34
EXP_A_RXN_9	T38
EXP_A_RXN_10	V34
EXP_A_RXN_11	W38
EXP_A_RXN_12	Y34
EXP_A_RXN_13	AA38
EXP_A_RXN_14	AB34
EXP_A_RXN_15	AC38
EXP_A_RXP_0	D34
EXP_A_RXP_1	F34
EXP_A_RXP_2	H38
EXP_A_RXP_3	J34
EXP_A_RXP_4	L38
EXP_A_RXP_5	M34
EXP_A_RXP_6	N38
EXP_A_RXP_7	P34
EXP_A_RXP_8	R38
EXP_A_RXP_9	T34
EXP_A_RXP_10	V38
EXP_A_RXP_11	W34
EXP_A_RXP_12	Y38
EXP_A_RXP_13	AA34
EXP_A_RXP_14	AB38
EXP_A_RXP_15	AC34
EXP_A_TXN_0	F36
EXP_A_TXN_1	G40
EXP_A_TXN_2	H36
EXP_A_TXN_3	J40
EXP_A_TXN_4	L36
EXP_A_TXN_5	M40
EXP_A_TXN_6	N36
EXP_A_TXN_7	P40
EXP_A_TXN_8	R36
EXP_A_TXN_9	T40
EXP_A_TXN_10	V36
EXP_A_TXN_11	W40
EXP_A_TXN_12	Y36
EXP_A_TXN_13	AA40
EXP_A_TXN_14	AB36
EXP_A_TXN_15	AC40
EXP_A_TXP_0	D36
EXP_A_TXP_1	F40
EXP_A_TXP_2	G36
EXP_A_TXP_3	H40
EXP_A_TXP_4	J36
EXP_A_TXP_5	L40
EXP_A_TXP_6	M36
EXP_A_TXP_7	N40
EXP_A_TXP_8	P36
EXP_A_TXP_9	R40
EXP_A_TXP_10	T36
EXP_A_TXP_11	V40
EXP_A_TXP_12	Y36
EXP_A_TXP_13	Y40
EXP_A_TXP_14	AA36
EXP_A_TXP_15	AB40

Max=500mil Zo=37.5 Ohm  
Chip to 150 Ohm R

Z84Fm V2.0 change R49 from 4.99K to 4.87K for Macro Vision issue

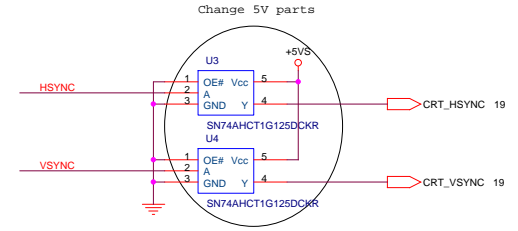

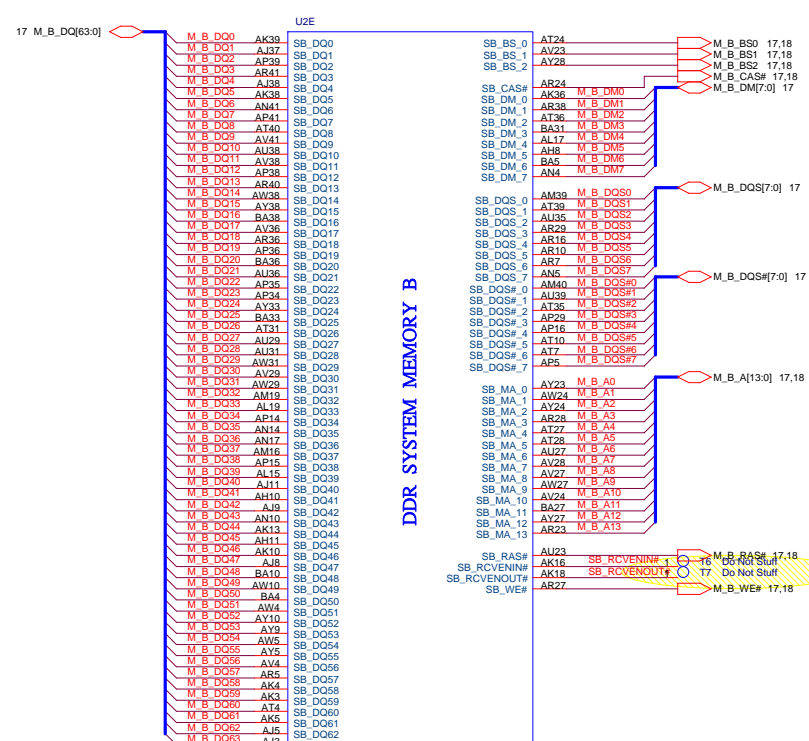
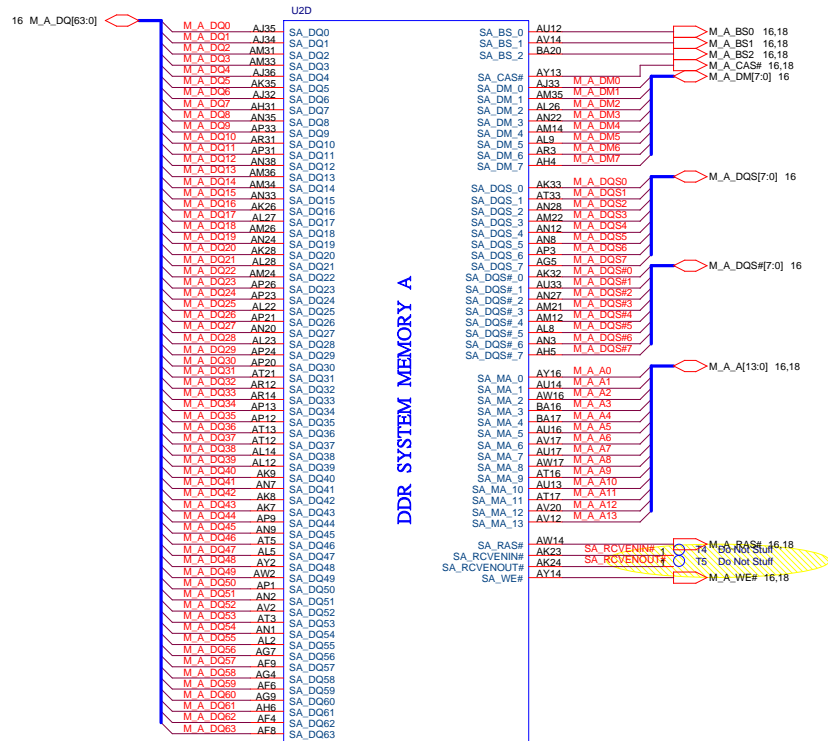

2.0G

**ASUS** Title : NB-945GM(DDR2)  
ASUSTeK COMPUTER INC. Engineer: Alan Chen

Size	Project Name	Rev
Custom	Z84FM	2.0

Date: Thursday, October 05, 2006 Sheet 8 of 57



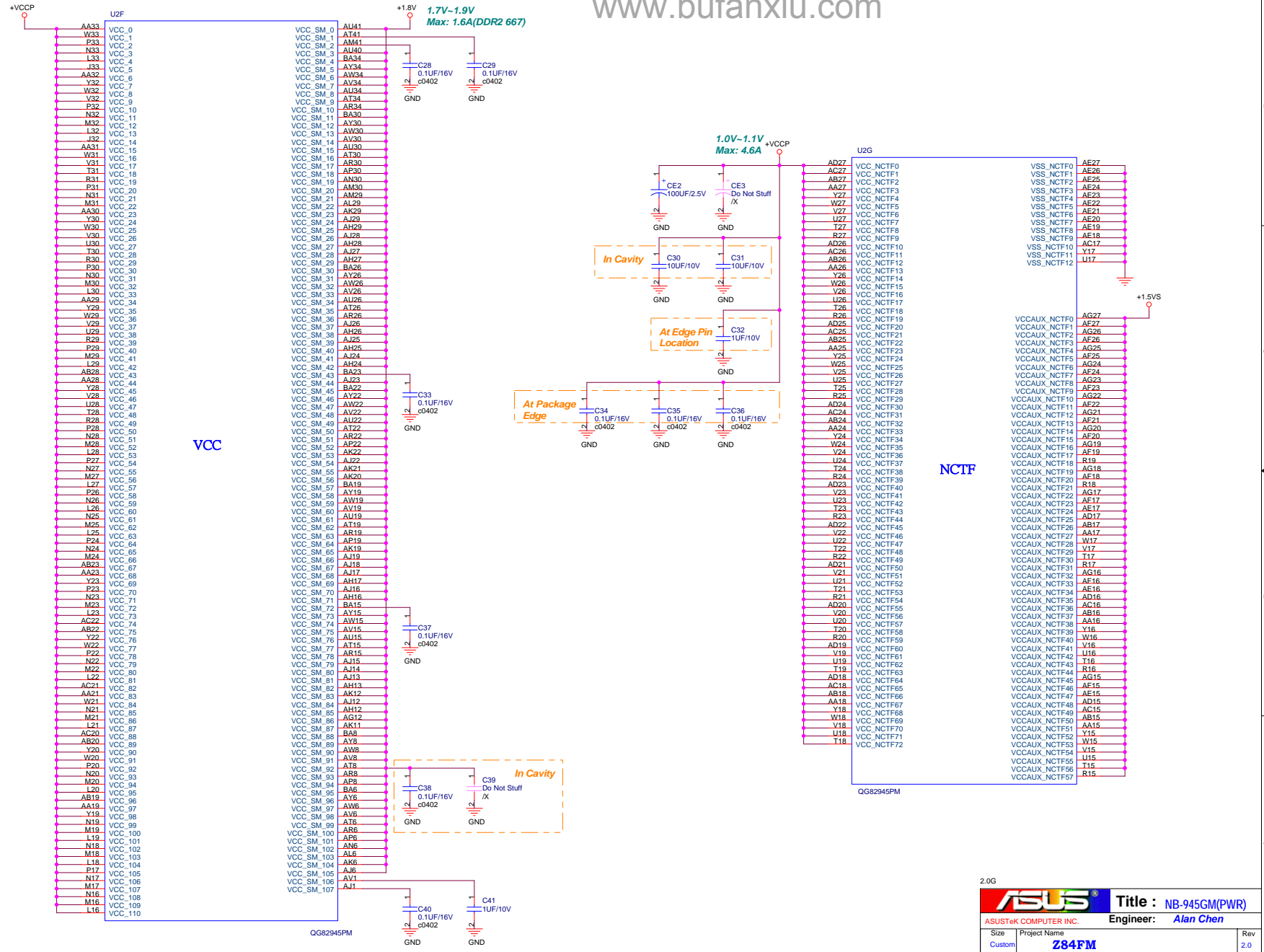

2.0G

**ASUS** Title : NB-945GM(PWR)  
 ASUSTeK COMPUTER INC. Engineer: Alan Chen  
 Size Project Name  
 Custom Z84FM Rev 2.0  
 Date: Thursday, October 05, 2006 Sheet 9 of 57

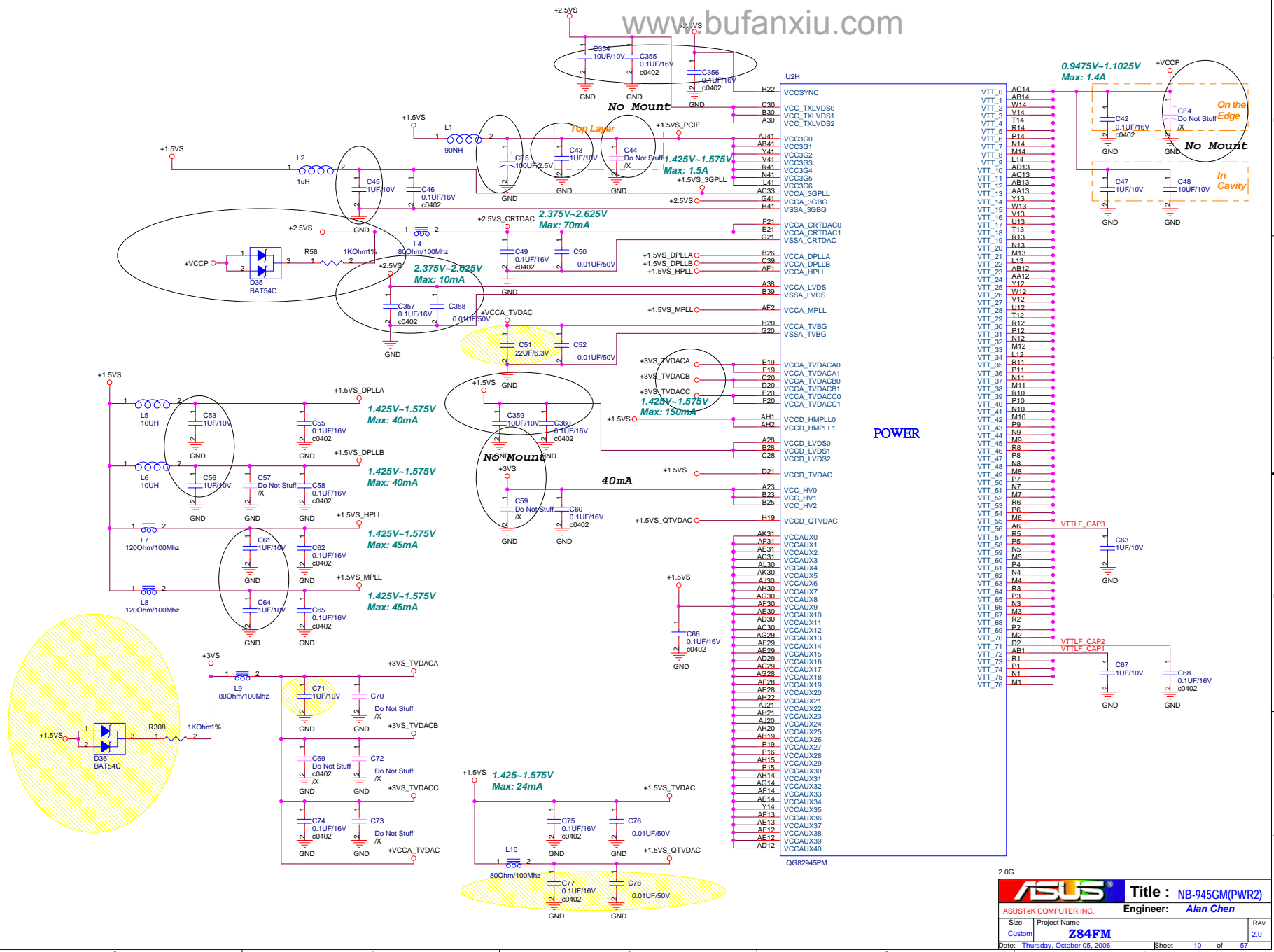

2.0G

**ASUS** Title : NB-945GM(PWR2)

ASUSTeK COMPUTER INC. Engineer: Alan Chen

Size	Project Name	Rev
Custom	Z84FM	2.0

Date: Thursday, October 05, 2006 Sheet 10 of 57

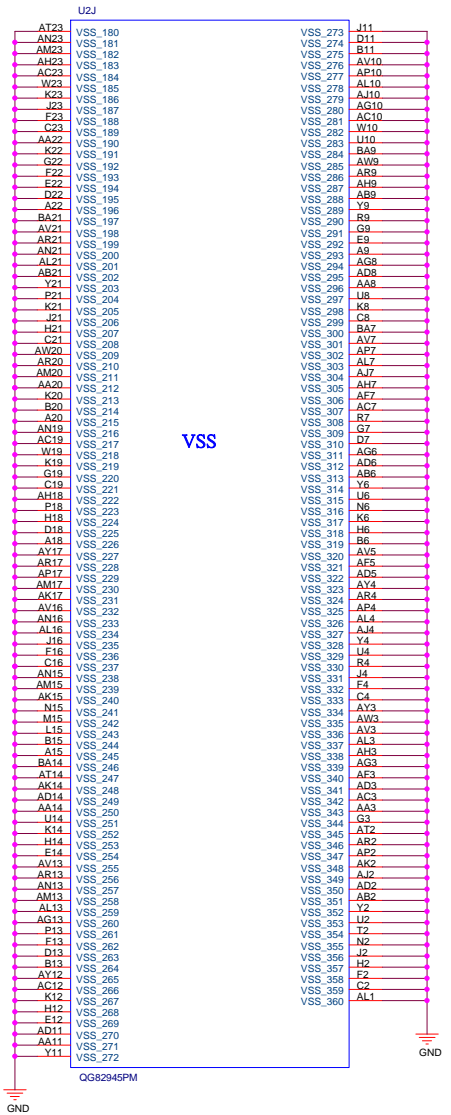
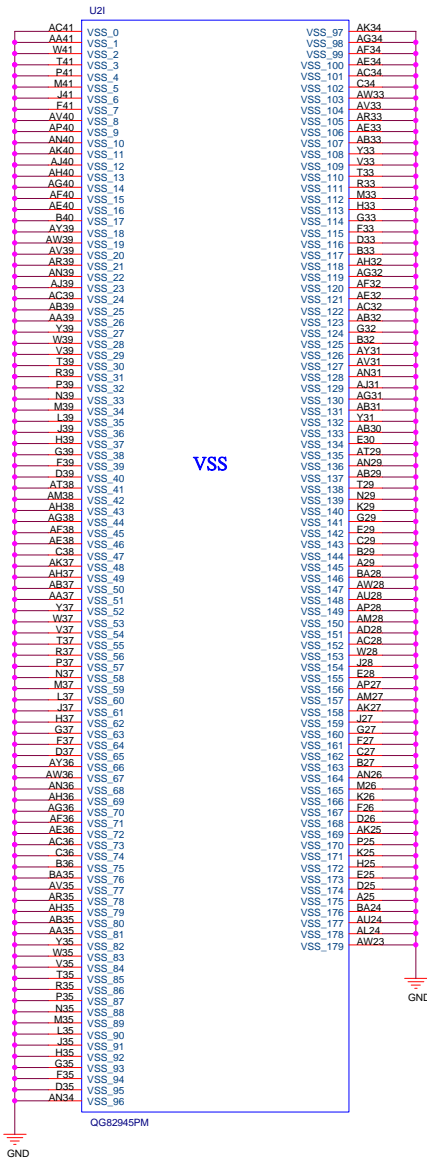

2.0G

<b>ASUS</b>		<b>Title : NB-945PM(GND)</b>	
ASUSTeK COMPUTER INC.		Engineer: Alan Chen	
Size	Project Name	Rev	
Custom	<b>Z84FM</b>	2.0	
Date: Thursday, October 05, 2006		Sheet	11 of 57

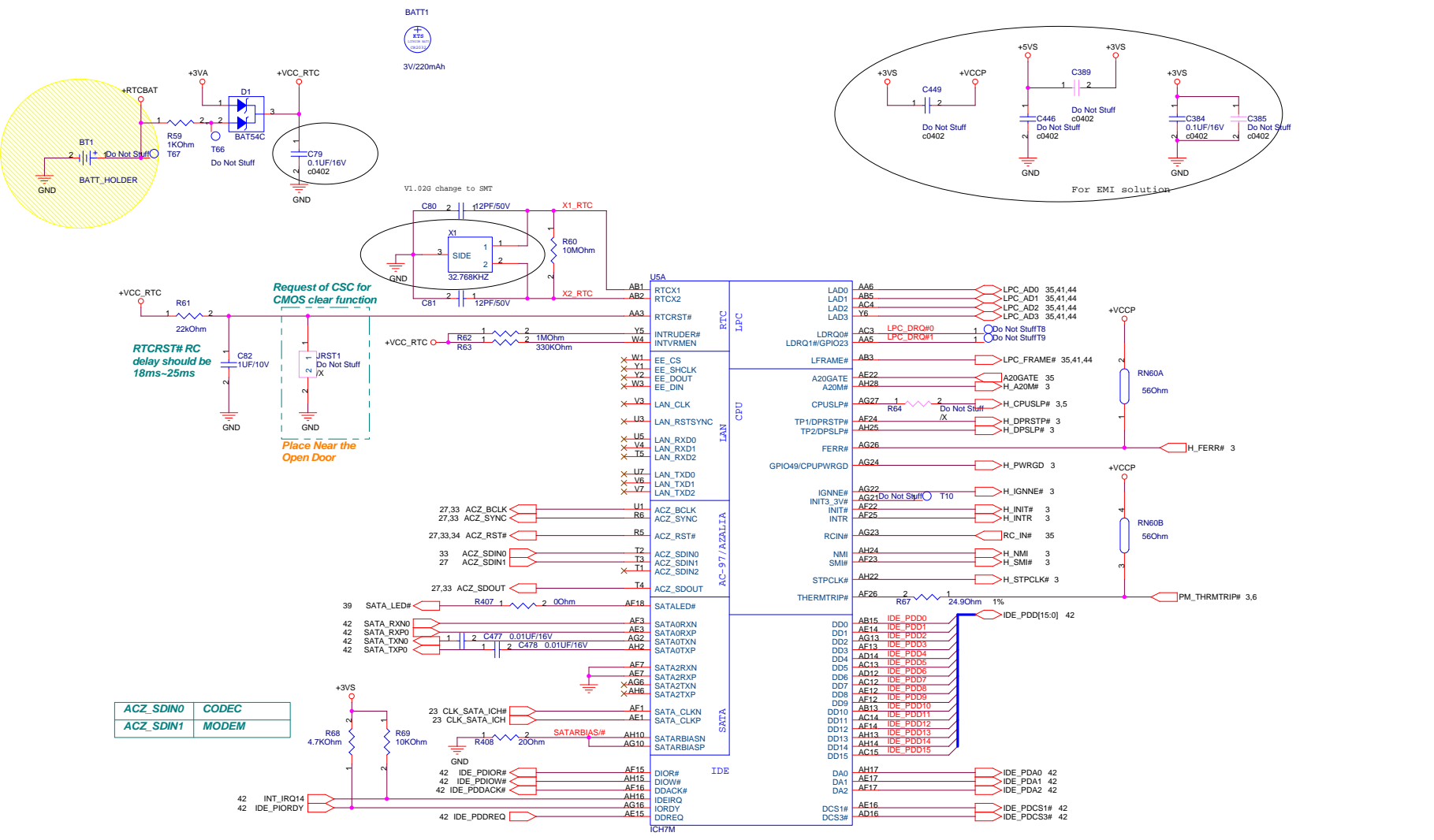

ACZ_SDIN0	CODEC
ACZ_SDIN1	MODEM

2.0G

**ASUS** Title : SB-ICH7-M(1)

ASUSTeK COMPUTER INC. Engineer: Alan Chen

Size	Project Name	Rev
Custom	Z84FM	2.0

Date: Thursday, October 05, 2006 Sheet 12 of 57

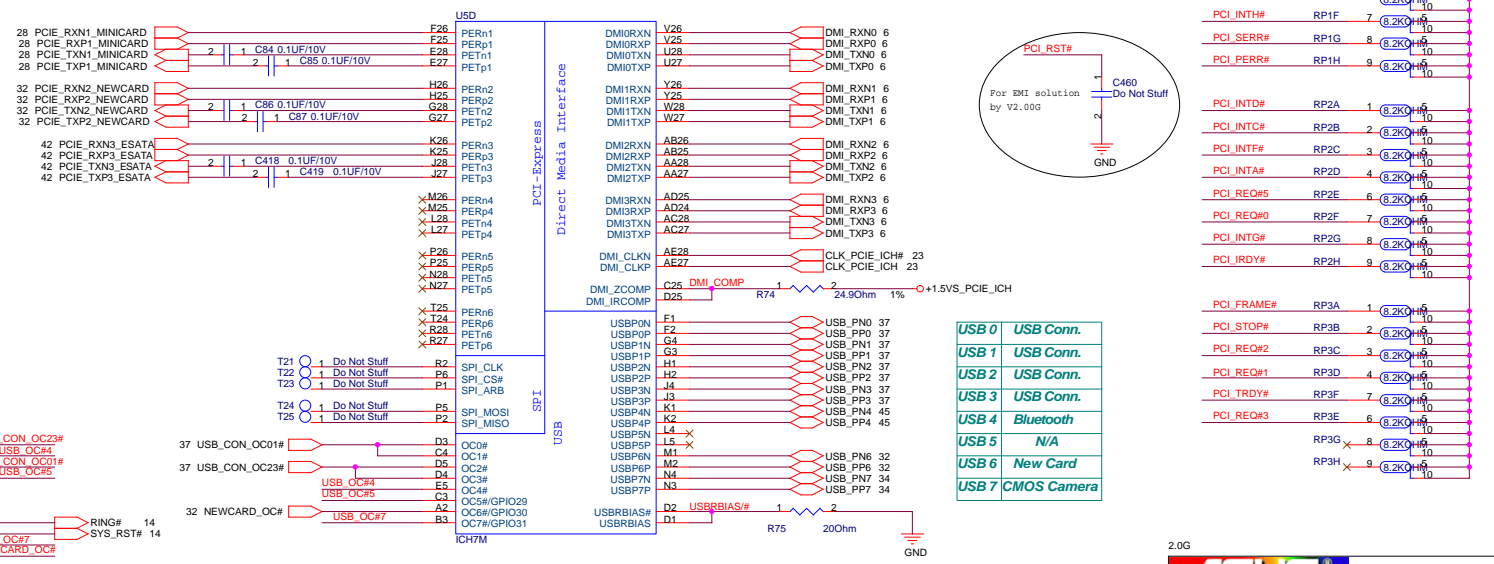
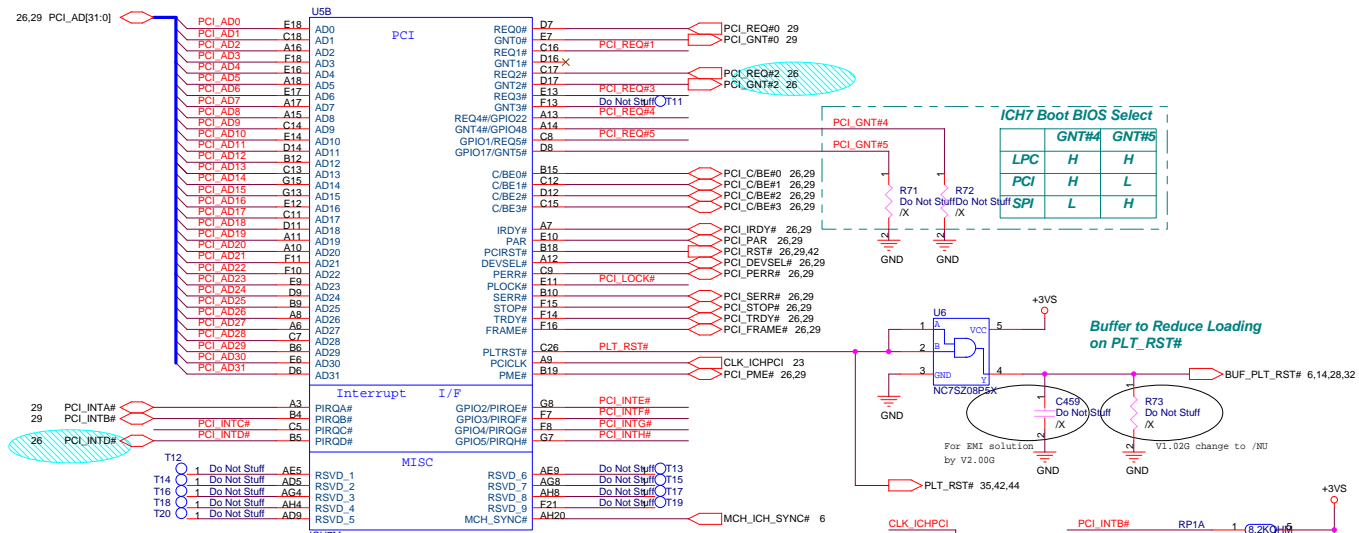

2.0G

**ASUS** Title : SB-ICH7M(2)

ASUSTeK COMPUTER INC. Engineer: Alan Chen

Size Project Name  
Custom Z84FM

Date: Thursday, October 05, 2006 Sheet 13 of 57

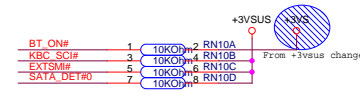
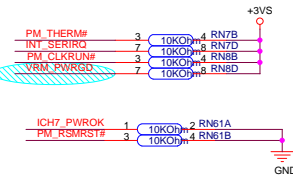
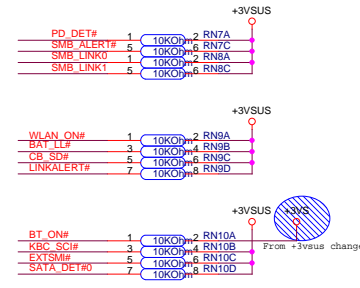
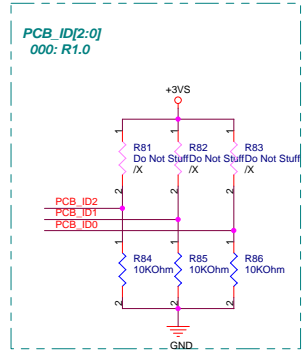
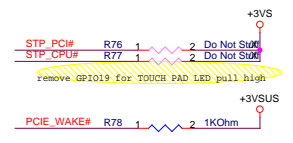
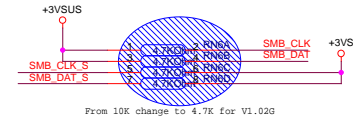
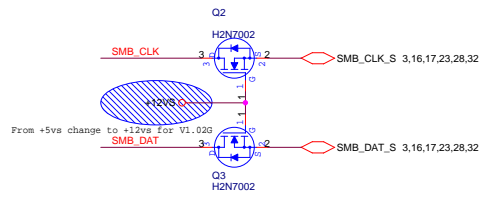
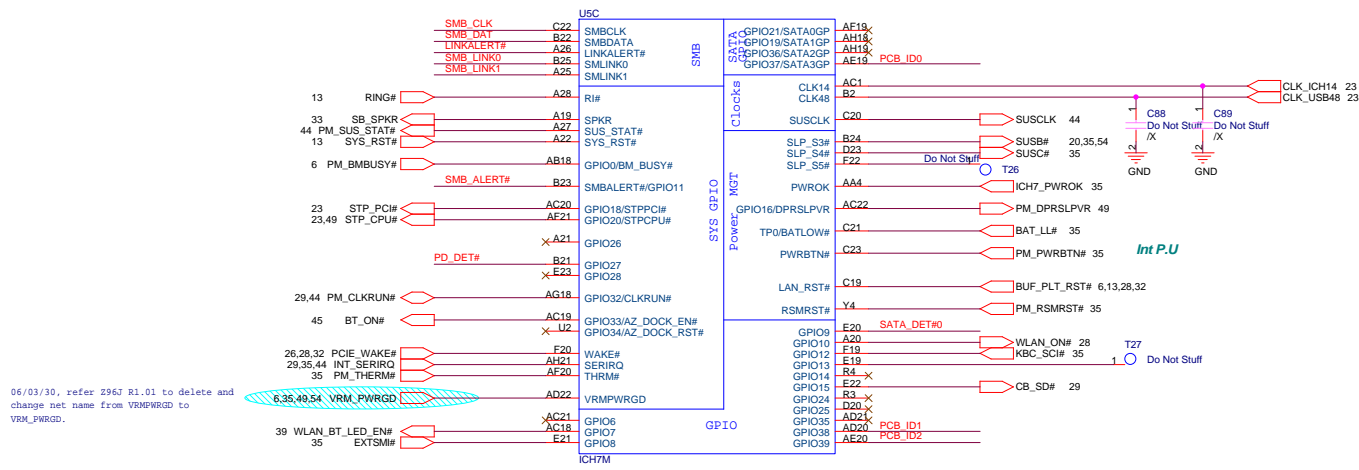

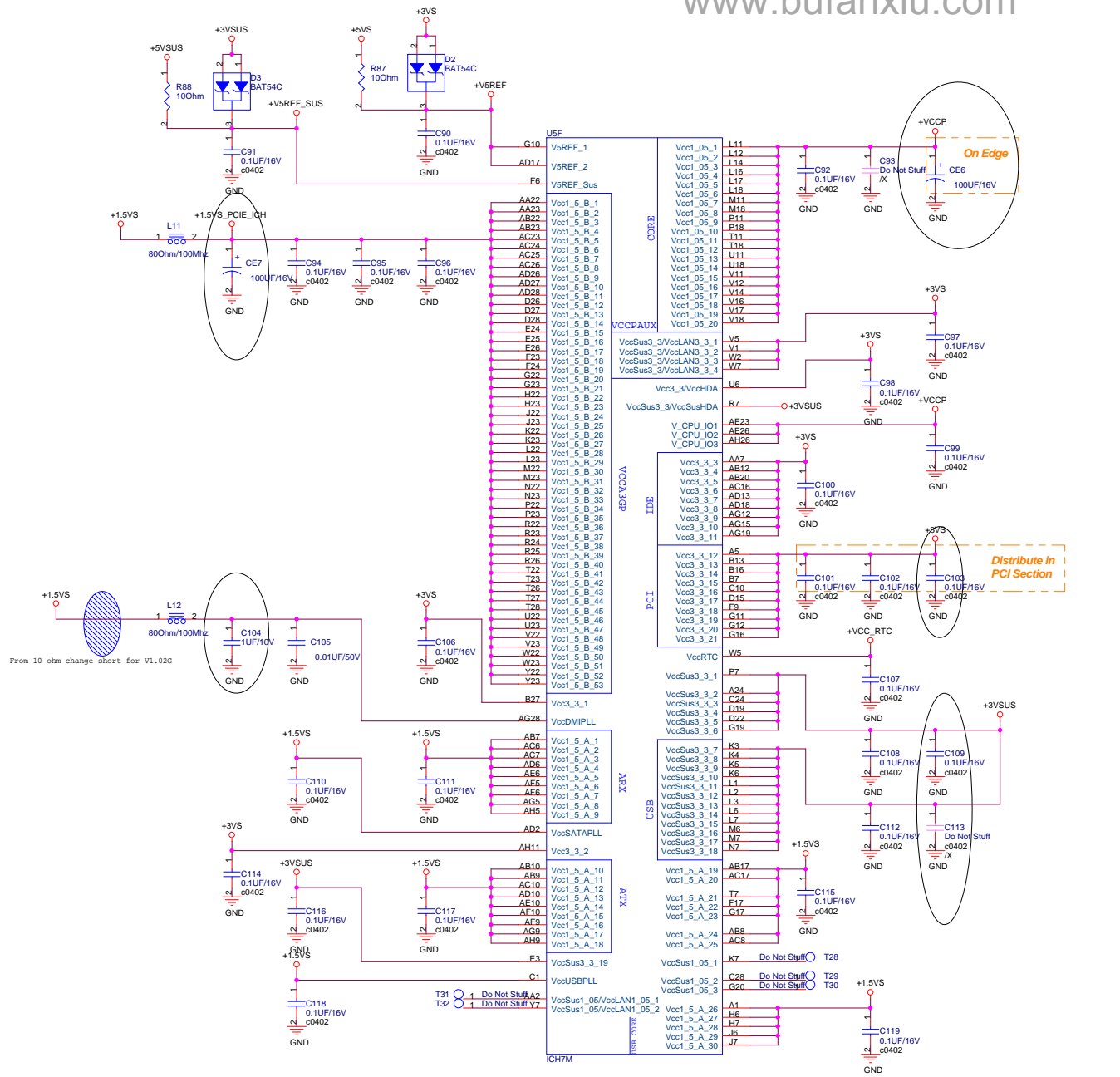

USE	Pin	Function
A4	Vas1	Vss98
A23	Vas2	Vss89
B1	Vas3	Vss100
B8	Vas4	Vss101
B11	Vas5	Vss102
B14	Vas6	Vss103
B17	Vas7	Vss104
B20	Vas8	Vss105
B26	Vas9	Vss106
B28	Vas10	Vss107
C2	Vas11	Vss108
C6	Vas12	Vss109
C27	Vas13	T12
D10	Vas14	T13
D13	Vas15	T14
D18	Vas16	T15
D21	Vas17	T16
D24	Vas18	T17
E1	Vas19	T18
E2	Vas20	T19
E4	Vas21	T20
E8	Vas22	Vss118
E15	Vas23	Vss119
F3	Vas24	Vss120
F5	Vas25	Vss121
F7	Vas26	Vss122
F12	Vas27	Vss123
F27	Vas28	Vss124
F28	Vas29	Vss125
G1	Vas30	Vss126
G2	Vas31	Vss127
G6	Vas32	Vss128
G8	Vas33	Vss129
G9	Vas34	Vss130
G18	Vas35	Vss131
G21	Vas36	Vss132
G24	Vas37	Vss133
G25	Vas38	Vss134
G26	Vas39	Vss135
H3	Vas40	Vss136
H4	Vas41	Vss137
H5	Vas42	Vss138
H24	Vas43	Vss139
H27	Vas44	Vss140
H28	Vas45	Vss141
J1	Vas46	Vss142
J2	Vas47	Vss143
J4	Vas48	Vss144
J24	Vas49	Vss145
J25	Vas50	Vss146
J26	Vas51	Vss147
J28	Vas52	Vss148
K24	Vas53	Vss149
K27	Vas54	Vss150
K28	Vas55	Vss151
L13	Vas56	Vss152
L15	Vas57	Vss153
L24	Vas58	Vss154
L26	Vas59	Vss155
L27	Vas60	Vss156
M3	Vas61	Vss157
M4	Vas62	Vss158
M5	Vas63	Vss159
M12	Vas64	Vss160
M14	Vas65	Vss161
M15	Vas66	Vss162
M16	Vas67	Vss163
M17	Vas68	Vss164
M24	Vas69	Vss165
M27	Vas70	Vss166
M28	Vas71	Vss167
N1	Vas72	Vss168
N2	Vas73	Vss169
N6	Vas74	Vss170
N11	Vas75	Vss171
N12	Vas76	Vss172
N13	Vas77	Vss173
N14	Vas78	Vss174
N15	Vas79	Vss175
N16	Vas80	Vss176
N17	Vas81	Vss177
N18	Vas82	Vss178
N24	Vas83	Vss179
N25	Vas84	Vss180
N26	Vas85	Vss181
P3	Vas86	Vss182
P4	Vas87	Vss183
P12	Vas88	Vss184
P13	Vas89	Vss185
P14	Vas90	Vss186
P15	Vas91	Vss187
P16	Vas92	Vss188
P17	Vas93	Vss189
P24	Vas94	Vss190
P27	Vas95	Vss191
P28	Vas96	Vss192
	Vas97	Vss193
	Vas98	Vss194

2.0G

**ASUS** Title : SB-ICH7M(PWR)

ASUSTeK COMPUTER INC. Engineer: Alan Chen

Size Project Name  
 Custom Z84FM  
 Date: Thursday, October 05, 2006 Sheet 15 of 57

M\_A\_DQ[63:0] 8

REV Type

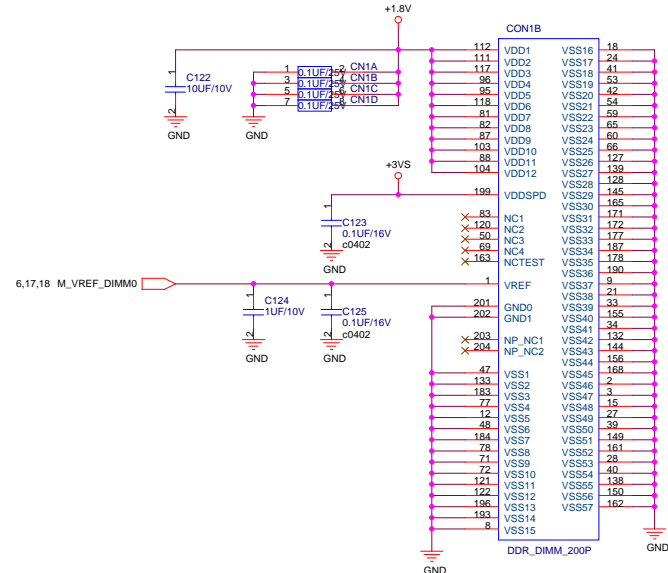
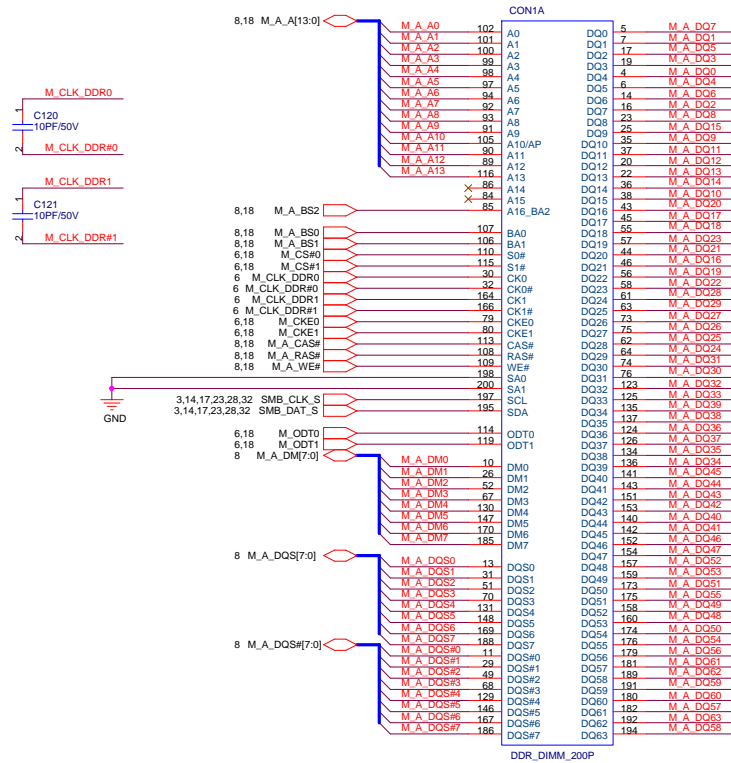

2.0G

**ASUS** Title : DDR2 SO-DIMM  
 ASUSTeK COMPUTER INC. Engineer: Alan Chen  
 Size Project Name  
 Custom Z84FM Rev 2.0  
 Date: Thursday, October 05, 2006 Sheet 16 of 57



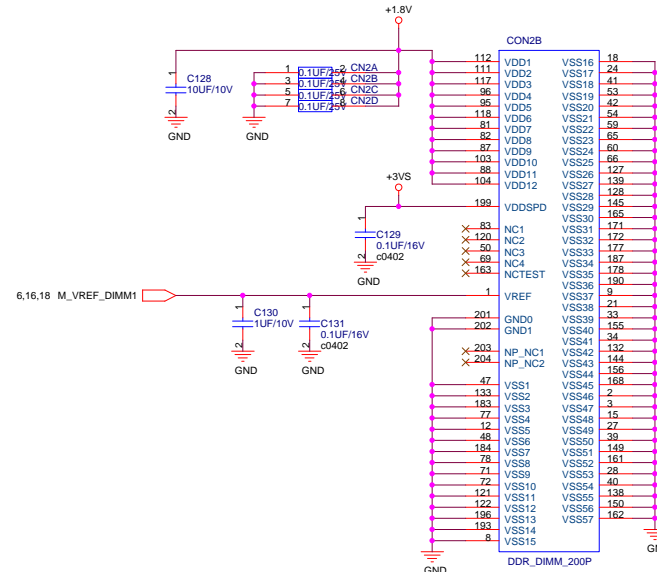
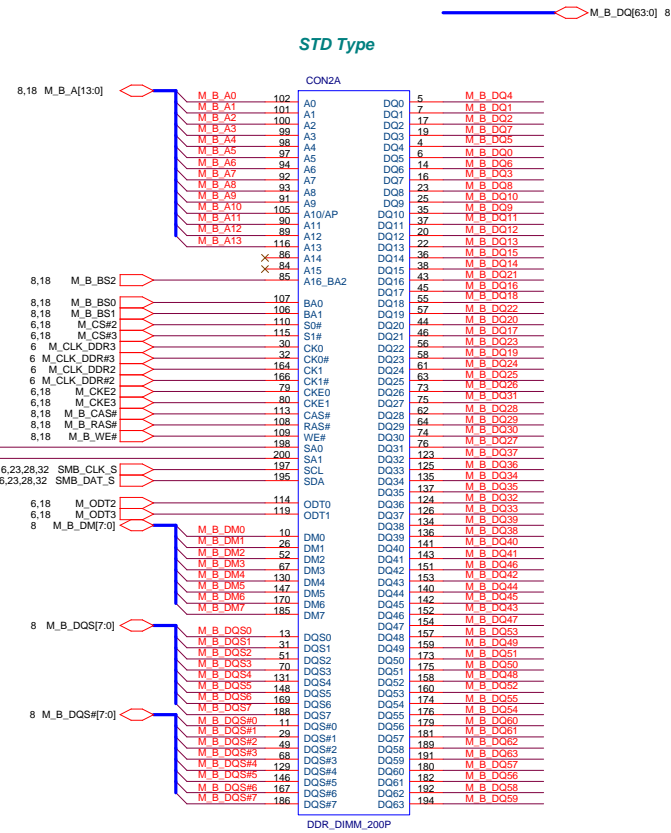

2.0G

**ASUS** Title : DDR2 SO-DIMM  
 ASUSTeK COMPUTER INC. NB1 Engineer: Alan Chen  
 Size Project Name  
 Custom Z84FM Rev 2.0  
 Date: Thursday, October 05, 2006 Sheet 17 of 57

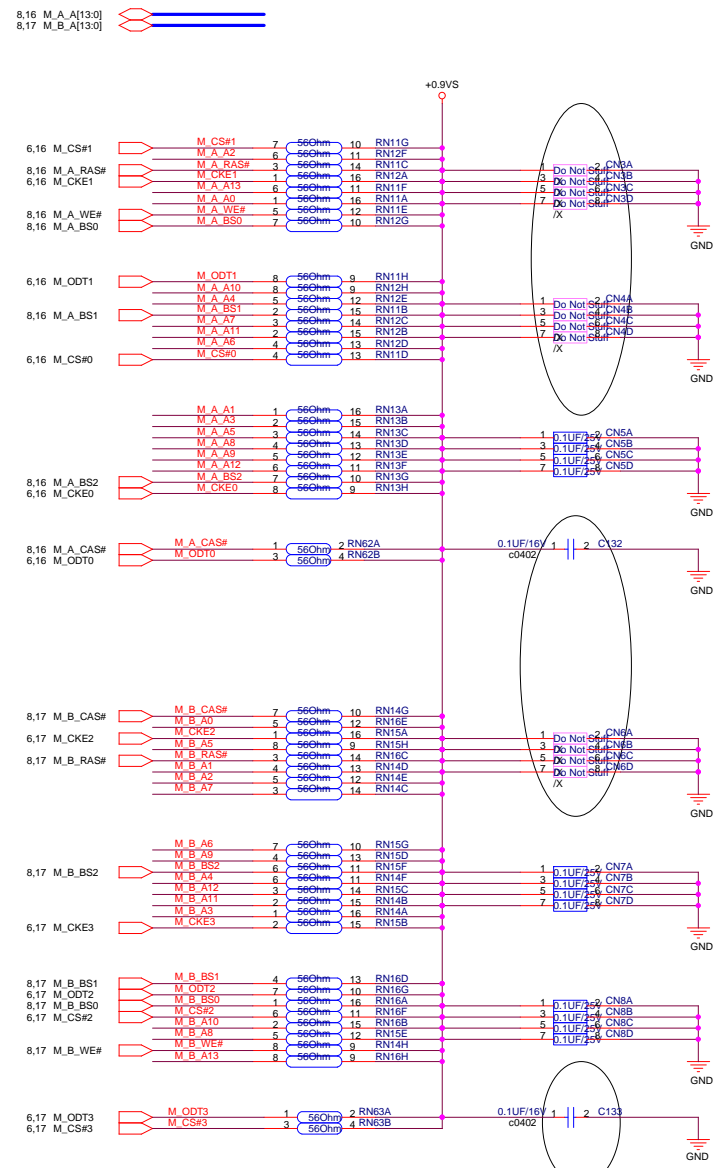
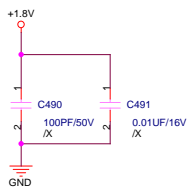
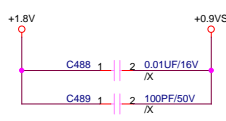
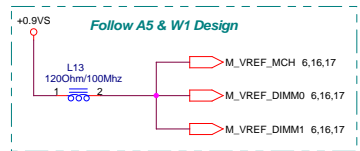

2.0G

**ASUS** Title : DDR2 TERMINATION

ASUSTeK COMPUTER INC. NB1 Engineer: Alan Chen

Size	Project Name	Rev
Custom	Z84FM	2.0

Date: Thursday, October 05, 2006 Sheet 18 of 57

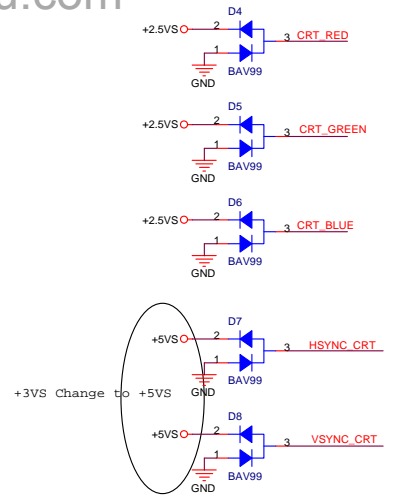
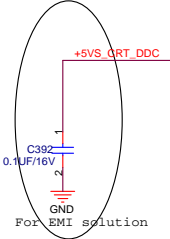
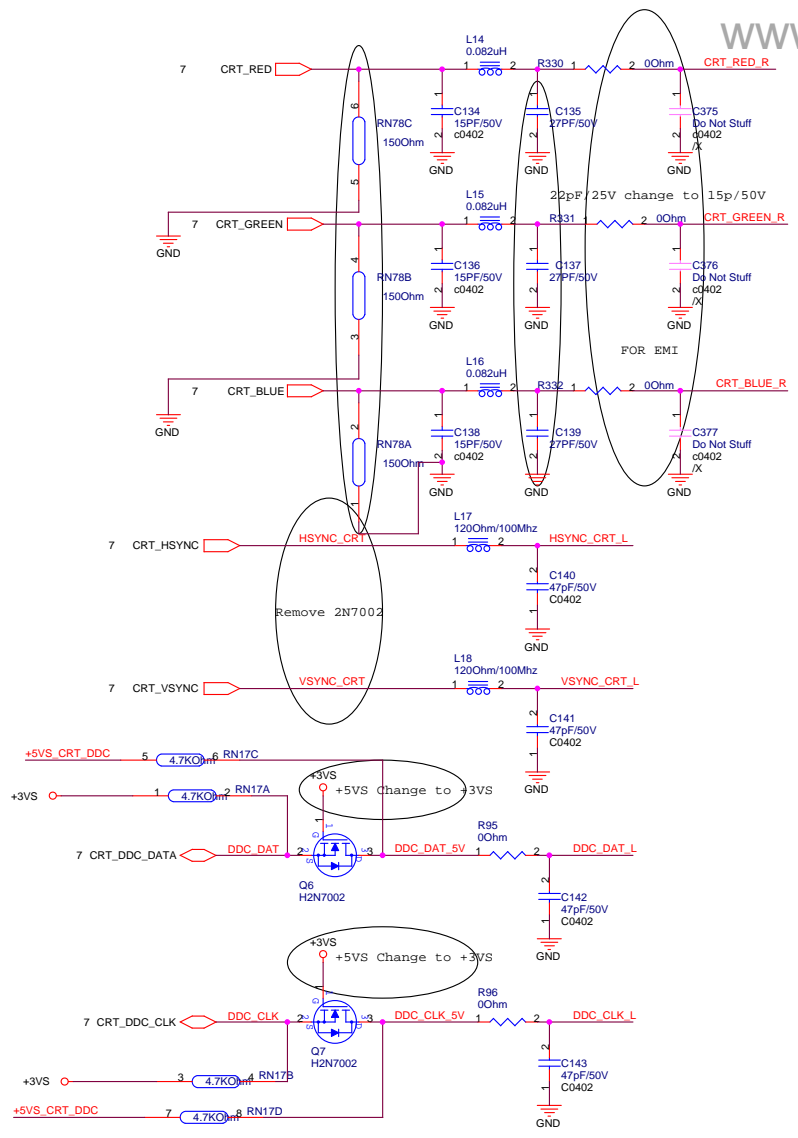

PLACE ESD Diodes near VGA port

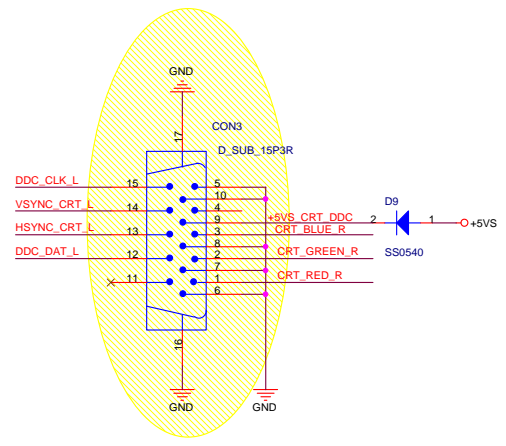

2.0G

<b>ASUS</b>		<b>Title : CRT</b>
ASUSTeK COMPUTER INC		Engineer: Alan Chen
Size	Project Name	Rev
Custom	<b>Z84FM</b>	2.0
Date: Thursday, October 05, 2006	Sheet	19 of 57

# LCD Backlight Control

# LCD LVDS Interface

3V-3.6V  
 Full Active: 3-3.6V  
 410 mA(Max. 500 mA)  
 SO-S1M:410 mA(500 mA Max.)

Cable Requirement:  
 Impedance: 100 ohm +/- 10%  
 Length Mismatch <= 10 mils  
 Twisted Pair(Not Ribbon)  
 Maximum Length <= 16"

Update pin define

## LCD Power

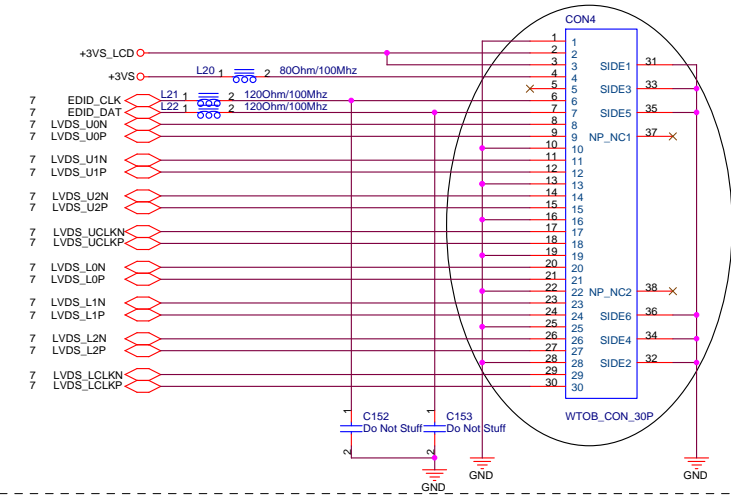
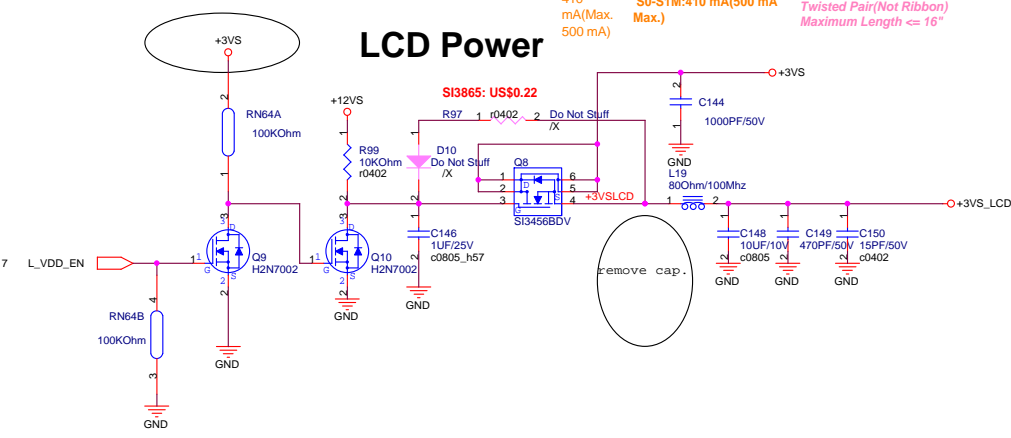

## INVERTER Interface/Speaker CONN.

BIOS  
 BACK\_OFF#:When user push "Fn+F7" button, BIOS active this pin to turn off back light.

PANEL ID1 = 1 : WSXGA+ 1680x1050  
 PANEL ID1 = 0 : WXGA 1280x800  
 PANEL ID0 RESERVE FOR VENDOR

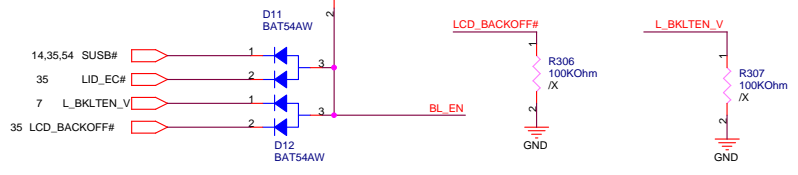
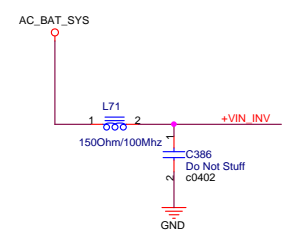
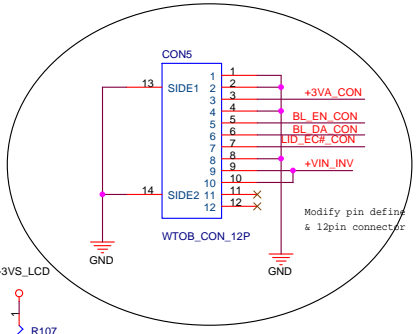
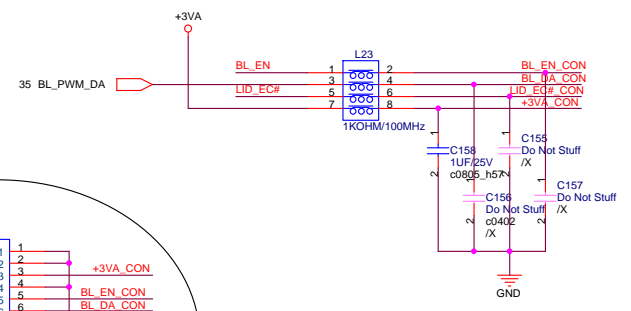

2.0G

<b>ASUS</b>		<b>Title :LVDS &amp; INVERTER</b>	
ASUSTeK COMPUTER INC		Engineer: Alan Chen	
Size	Project Name	Rev	
Custom	<b>Z84FM</b>	2.0	
Date: Thursday, October 05, 2006	Sheet	20	of 57

# TV OUT

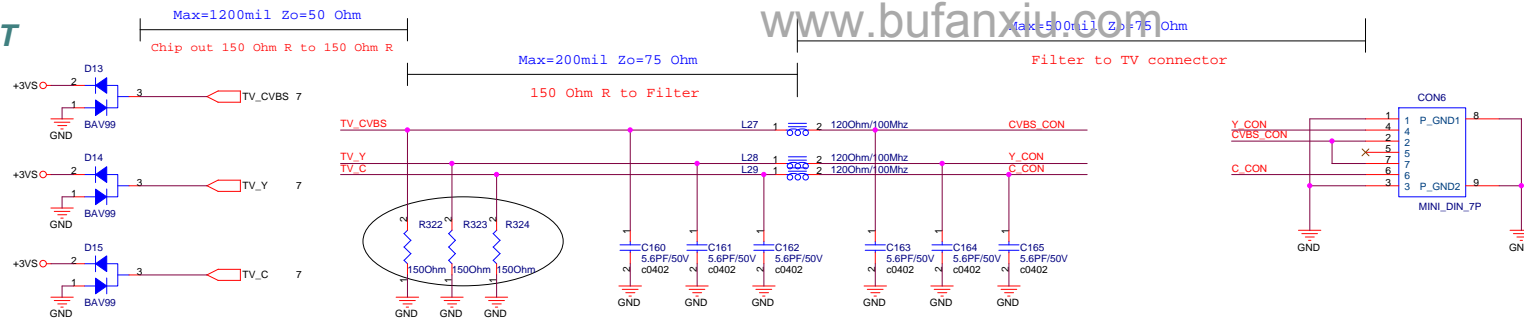

PLACE ESD Diodes near TV port

2.0G

<b>ASUS</b>		<b>Title : TV OUT &amp; DVI CON.</b>	
ASUSTeK COMPUTER INC		Engineer: Alan Chen	
Size	Project Name	Rev	
Custom	<b>Z84FM</b>	2.0	
Date: Thursday, October 05, 2006		Sheet	21 of 57

### Thermal Sensor

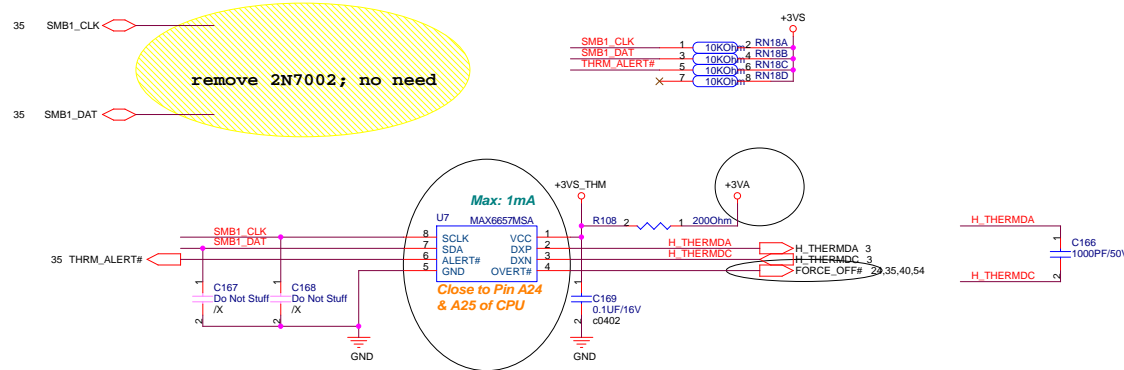

### DC FAN Control

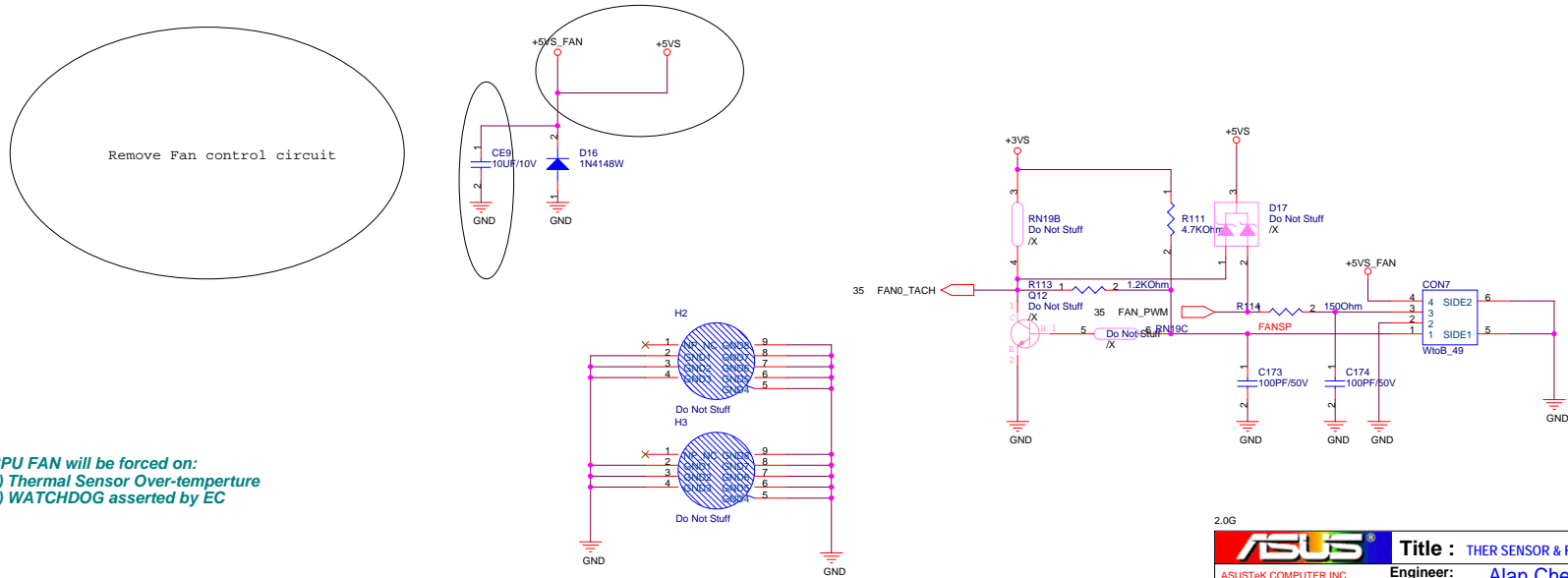

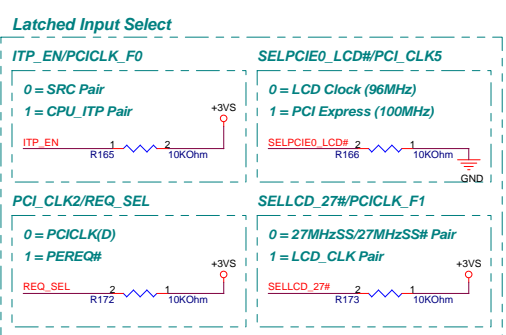
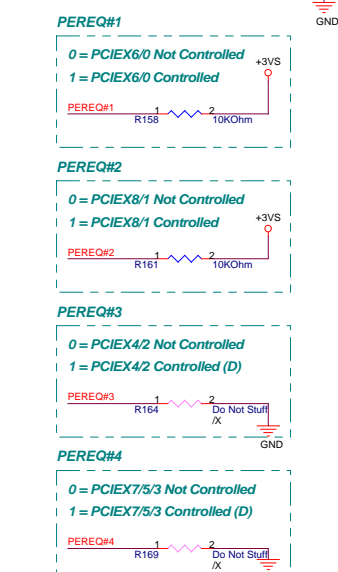
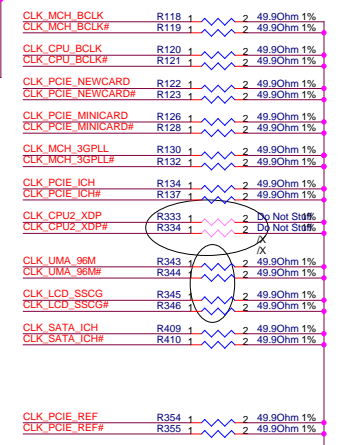
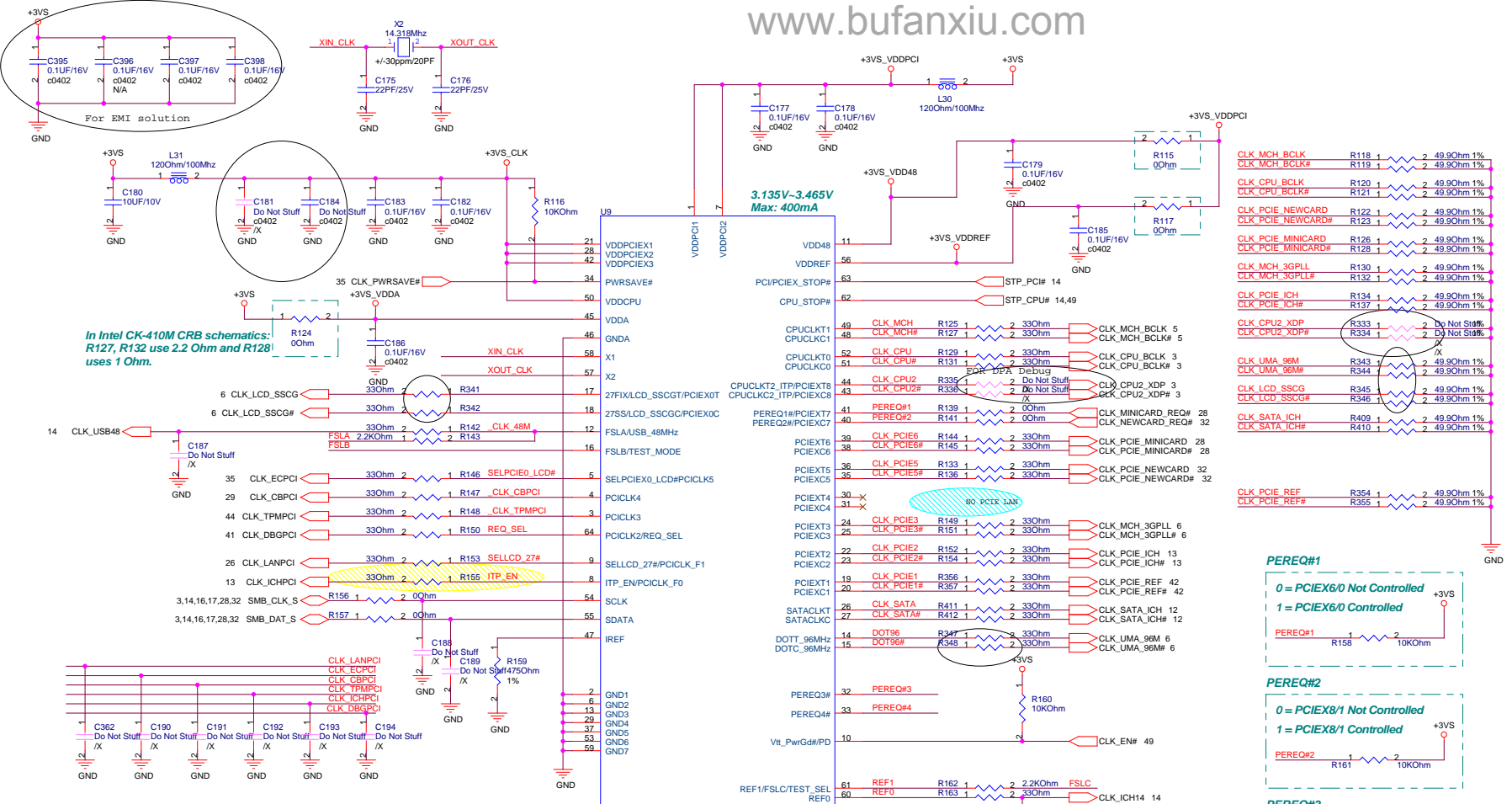

BCLK	FSB	BSEL2	BSEL1	BSEL0
133	533	L	L	H
166	667	L	H	H

2.0G

**ASUS** Title : **CLK GEN-IC954310**

ASUSTek COMPUTER INC. Engineer: **Alan Chen**

Size Project Name  
Custom **Z84FM**

Date: Thursday, October 05, 2006 Sheet 23 of 57

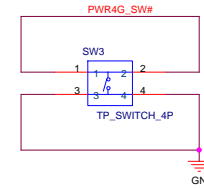
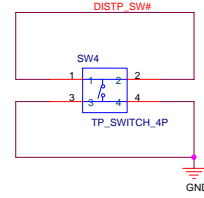
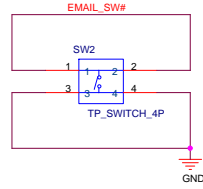
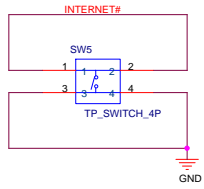

SHUT\_DOWN#

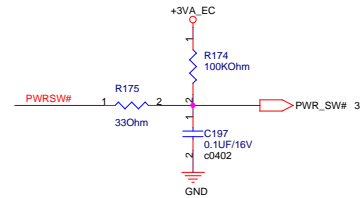
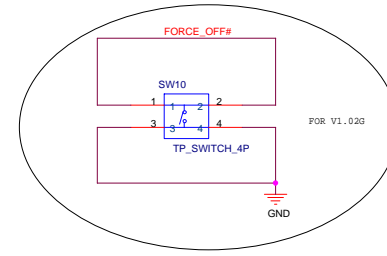
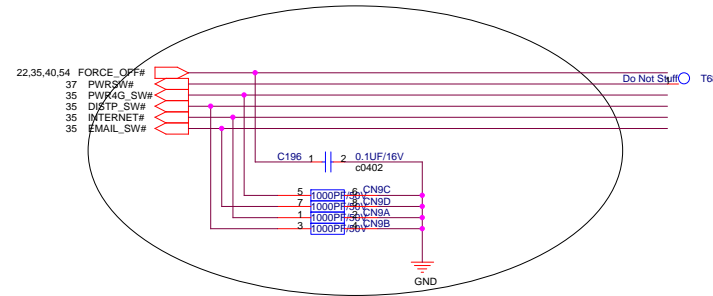
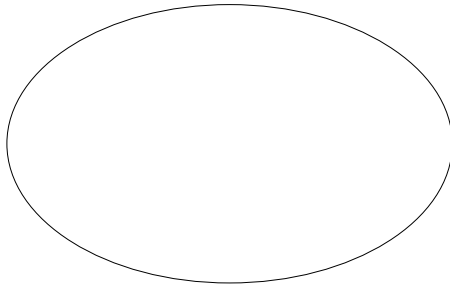

2.0G



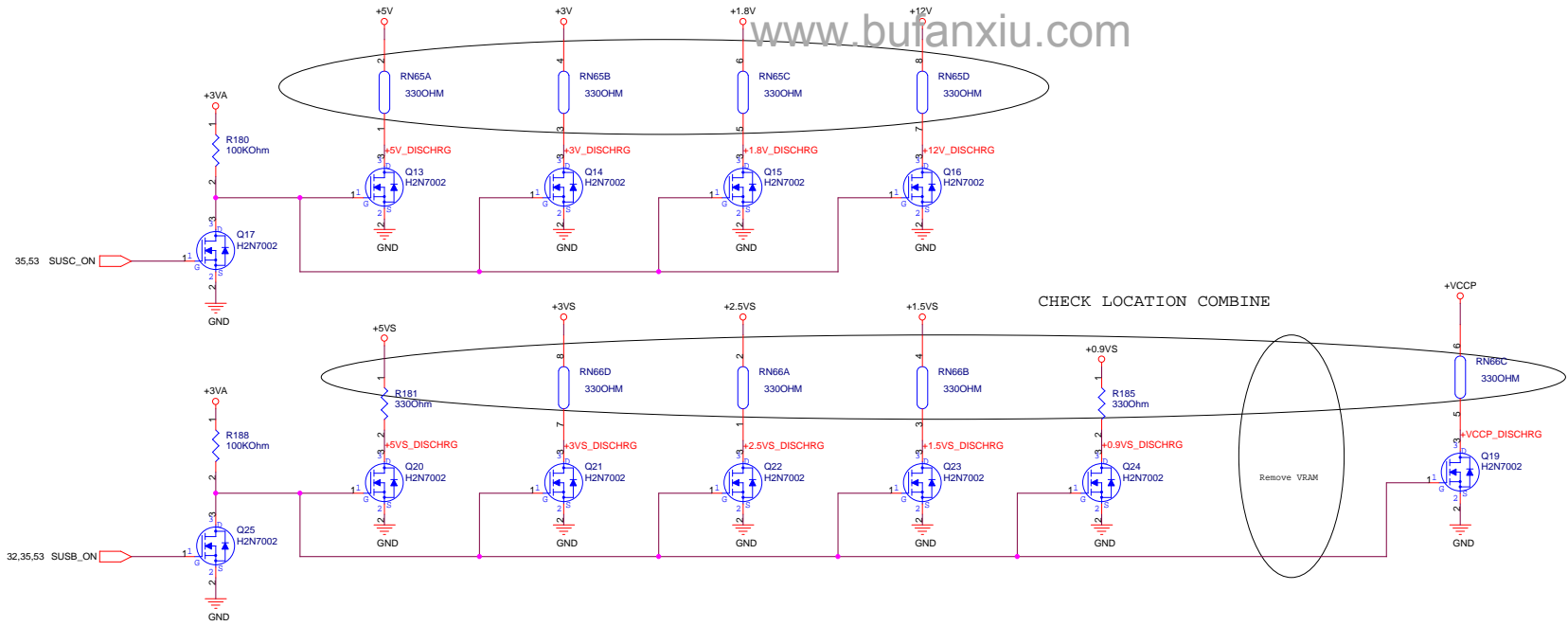

2.0G

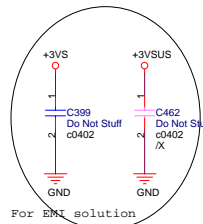
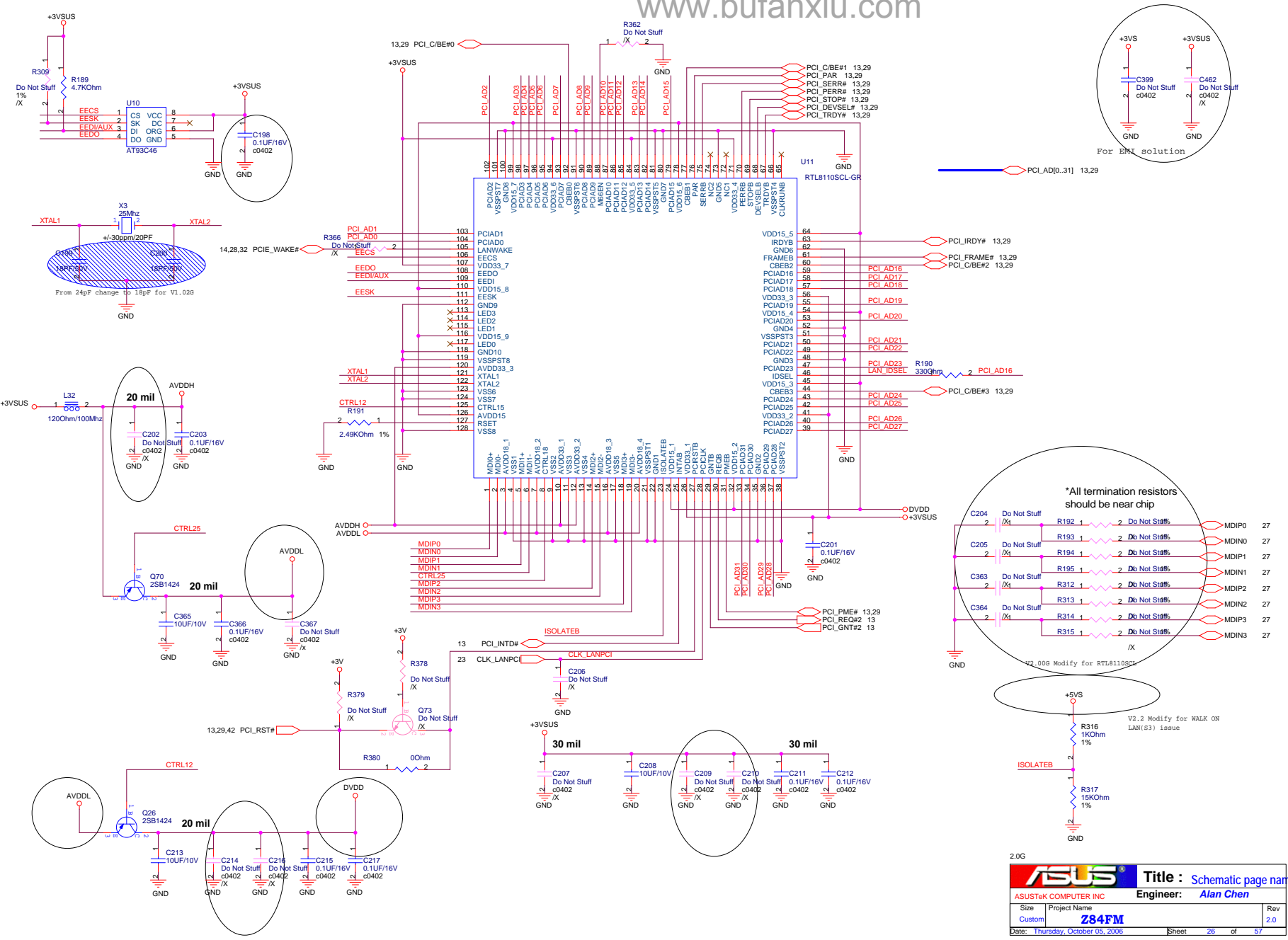

For EMI solution

PCI\_AD[0..31] 13,29

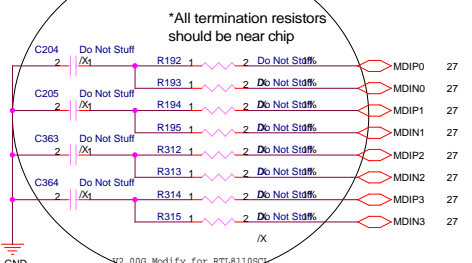

V2.000 Modify for RTL8110SCL

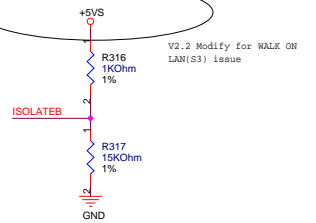

2.0G

MDC CONN.

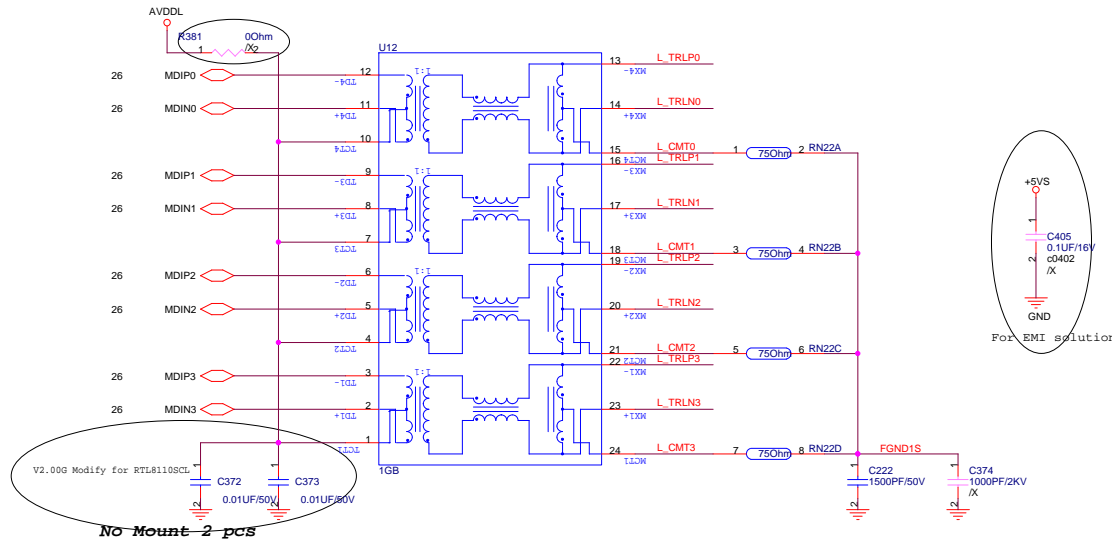
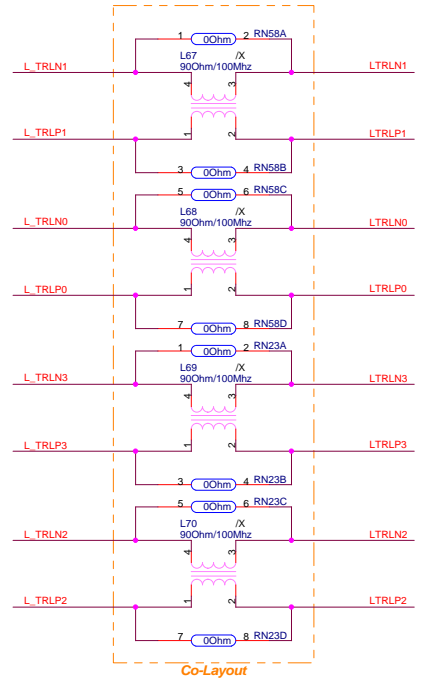
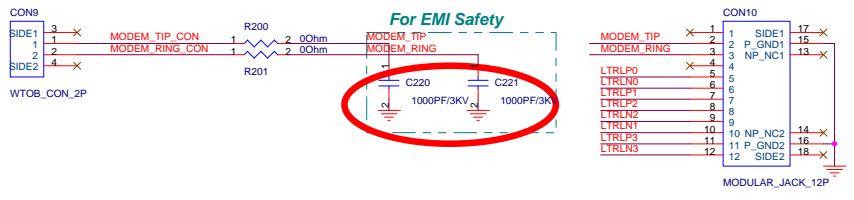
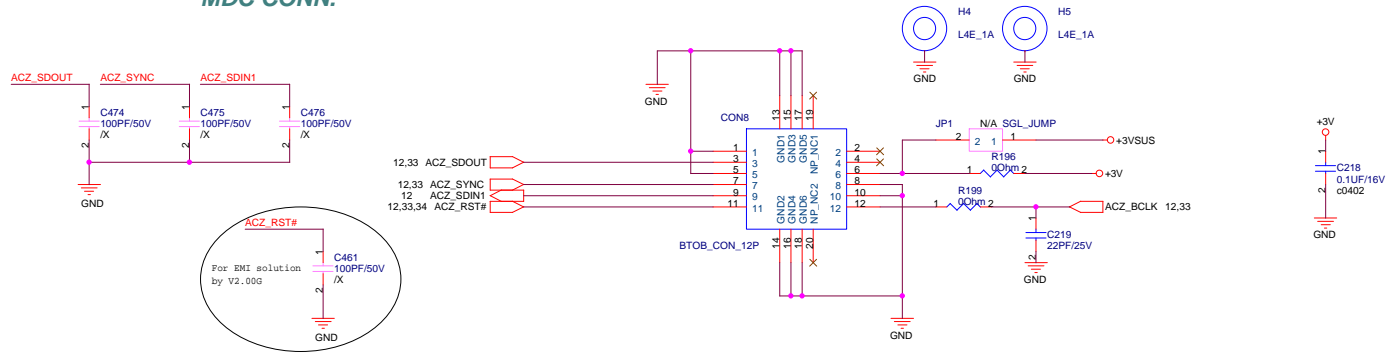

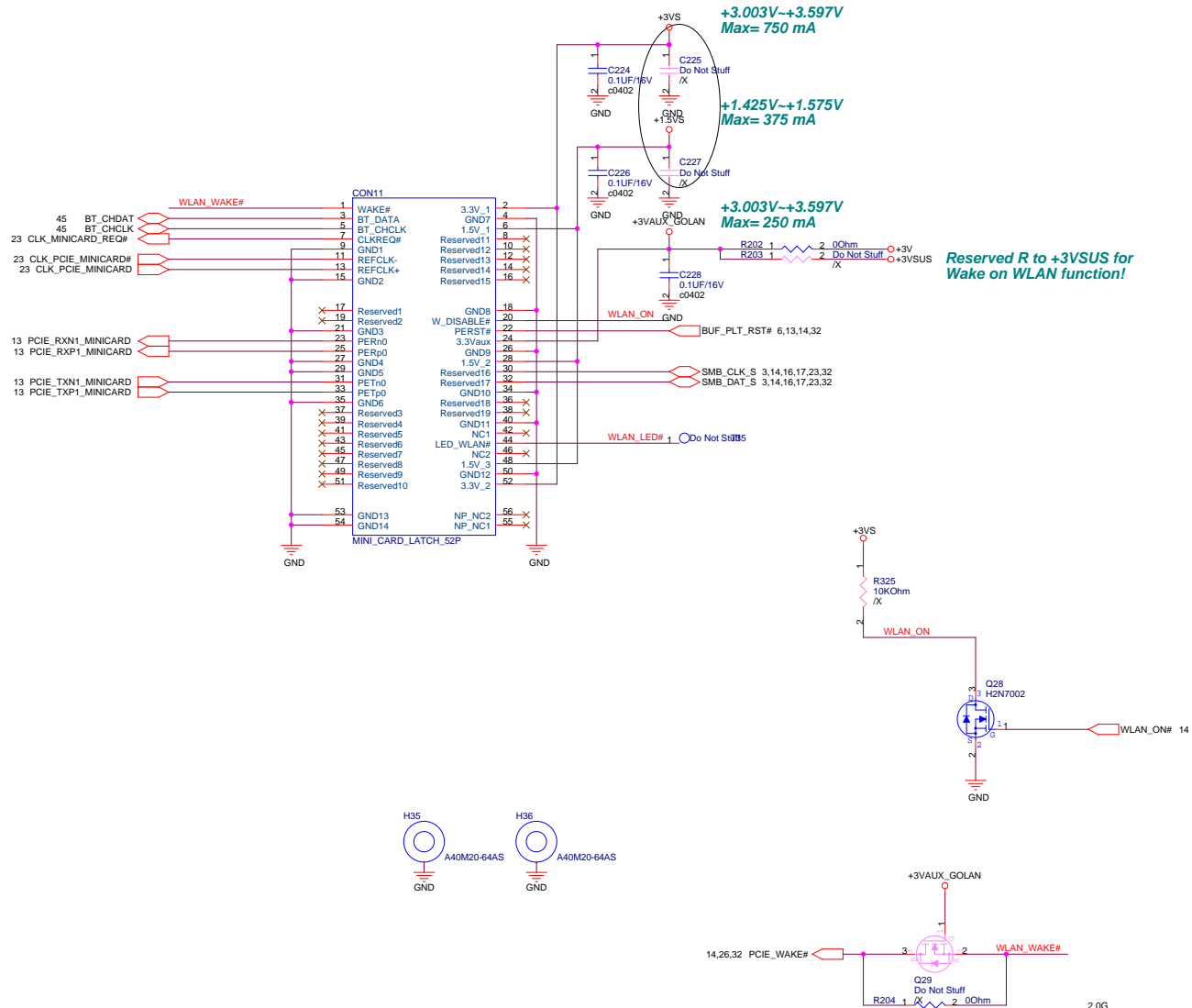

2.0G

**ASUS** Title : MINICARD

ASUSTeK COMPUTER INC. Engineer: Alan Chen

Size	Project Name	Rev
Custom	Z84FM	2.0

Date: Thursday, October 05, 2006 Sheet 28 of 57

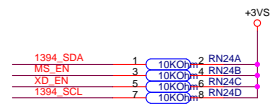
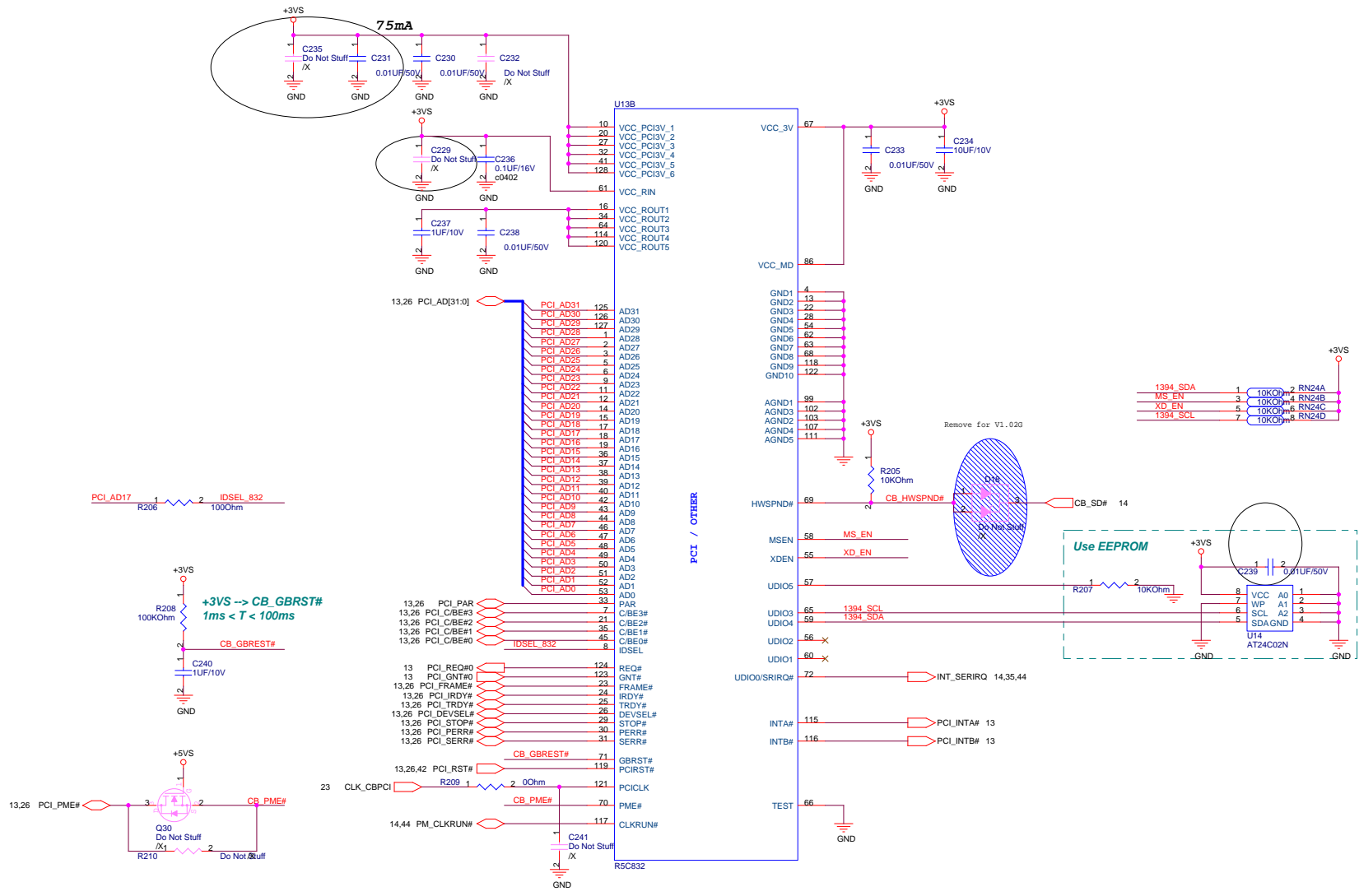

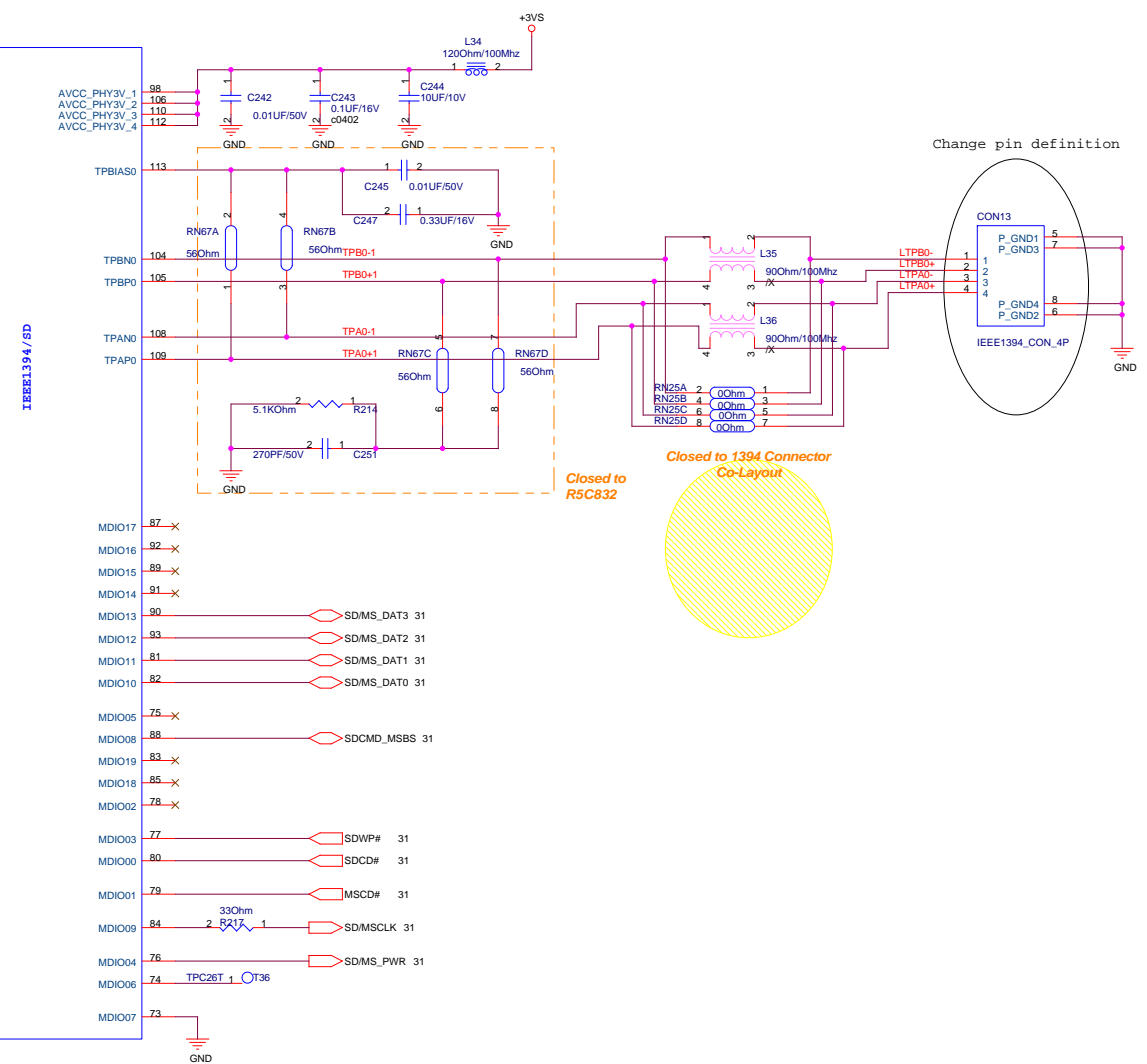
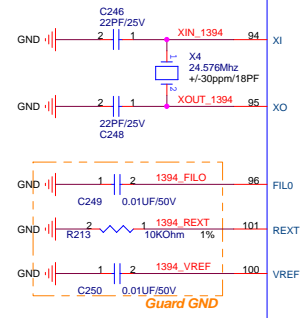
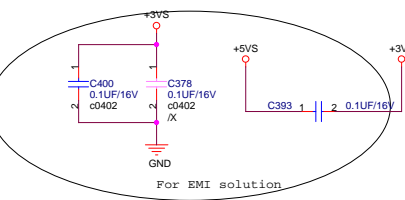

- MDIO17
  - MDIO16
  - MDIO15
  - MDIO14
  - MDIO13
  - MDIO12
  - MDIO11
  - MDIO10
  - MDIO05
  - MDIO08
  - MDIO19
  - MDIO18
  - MDIO02
  - MDIO03
  - MDIO00
  - MDIO01
  - MDIO09
  - MDIO04
  - MDIO06
  - MDIO07
- SDMS\_DAT3 31
  - SDMS\_DAT2 31
  - SDMS\_DAT1 31
  - SDMS\_DAT0 31
  - SDCMD\_MSBS 31
  - SDWP# 31
  - SDCD# 31
  - MSCD# 31
  - SDMSCLK 31
  - SDMS\_PWR 31

2.0G

**ASUS** Title : CARD1394-R5C832(2)

ASUSTeK COMPUTER INC. MB6 Engineer: ALAN Chen

Size	Project Name	Rev
Custom	Z84FM	2.0

Date: Thursday, October 05, 2006 Sheet 30 of 57

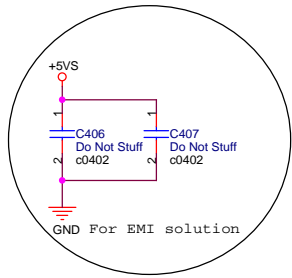

- SD/MS\_DAT3 30
- SD/MS\_DAT2 30
- SD/MS\_DAT1 30
- SD/MS\_DAT0 30
- SDCMD\_MSBS 30
- SDWP# 30
- SDCD# 30
- MSCD# 30
- SD/MSCLK 30
- SD/MS\_PWR 30

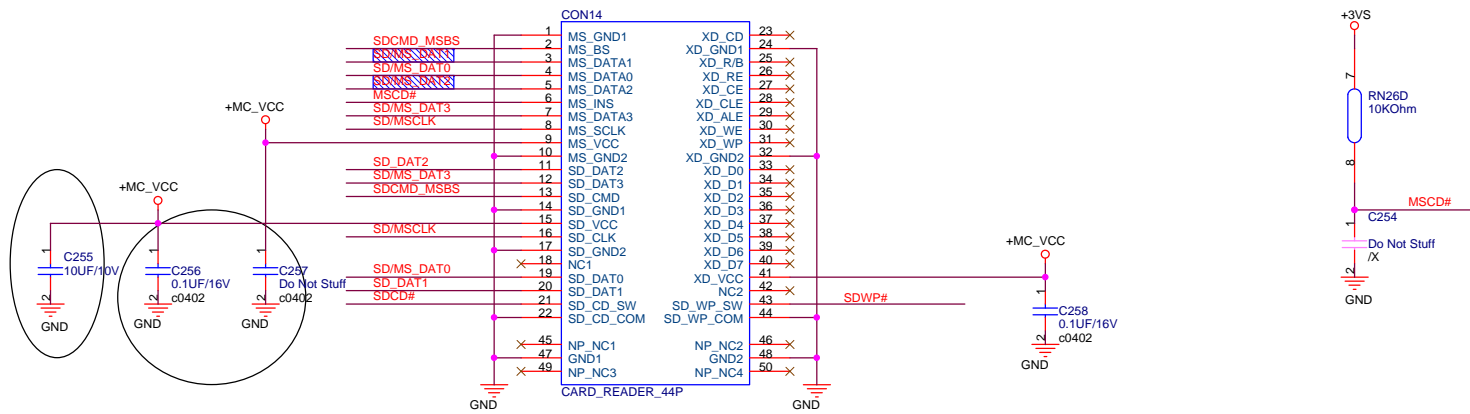
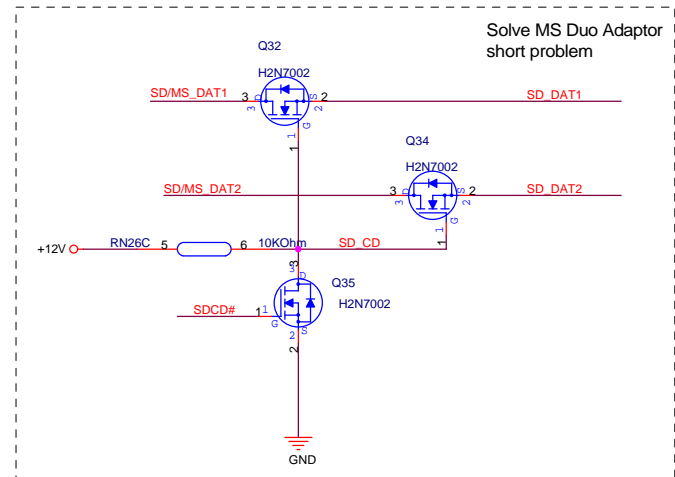
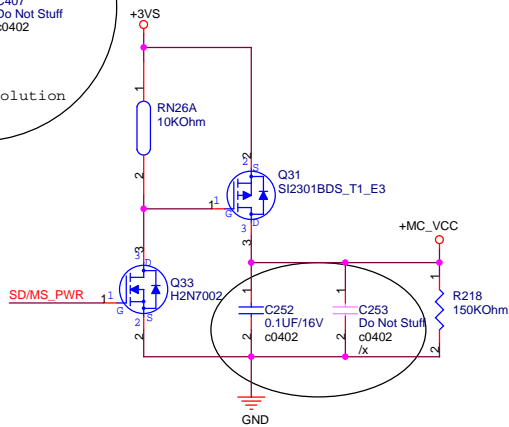









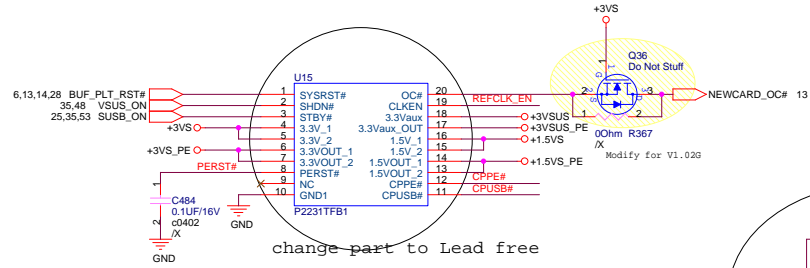
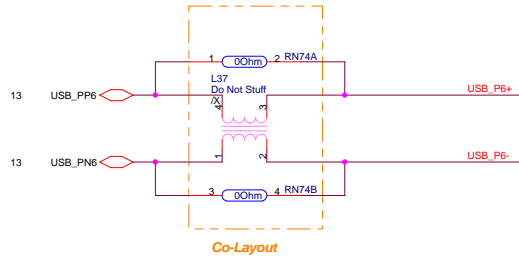

change part to Lead free

!! ExpressCard Standard 1.0:  
Change Pin7 from RESERVED to SMBCLK  
Change Pin8 from SMBCLK to SMBDATA  
Change Pin9 from SMBDATA to +1.5V

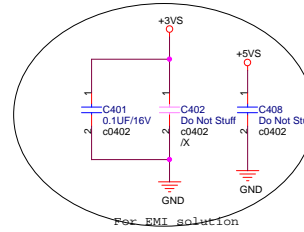
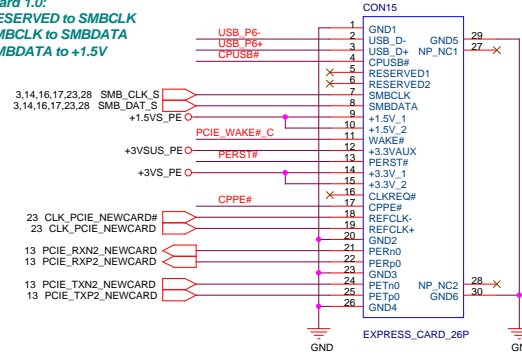

NewCard Ejecter

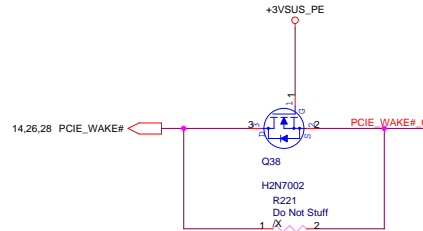
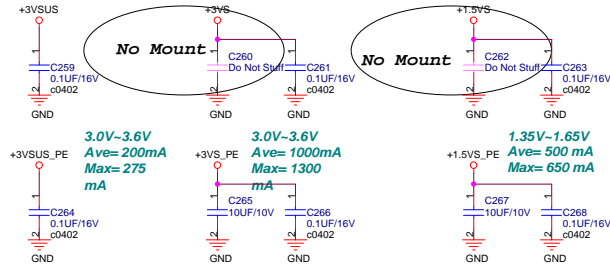
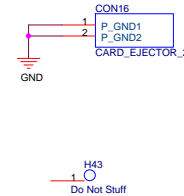

2.0G

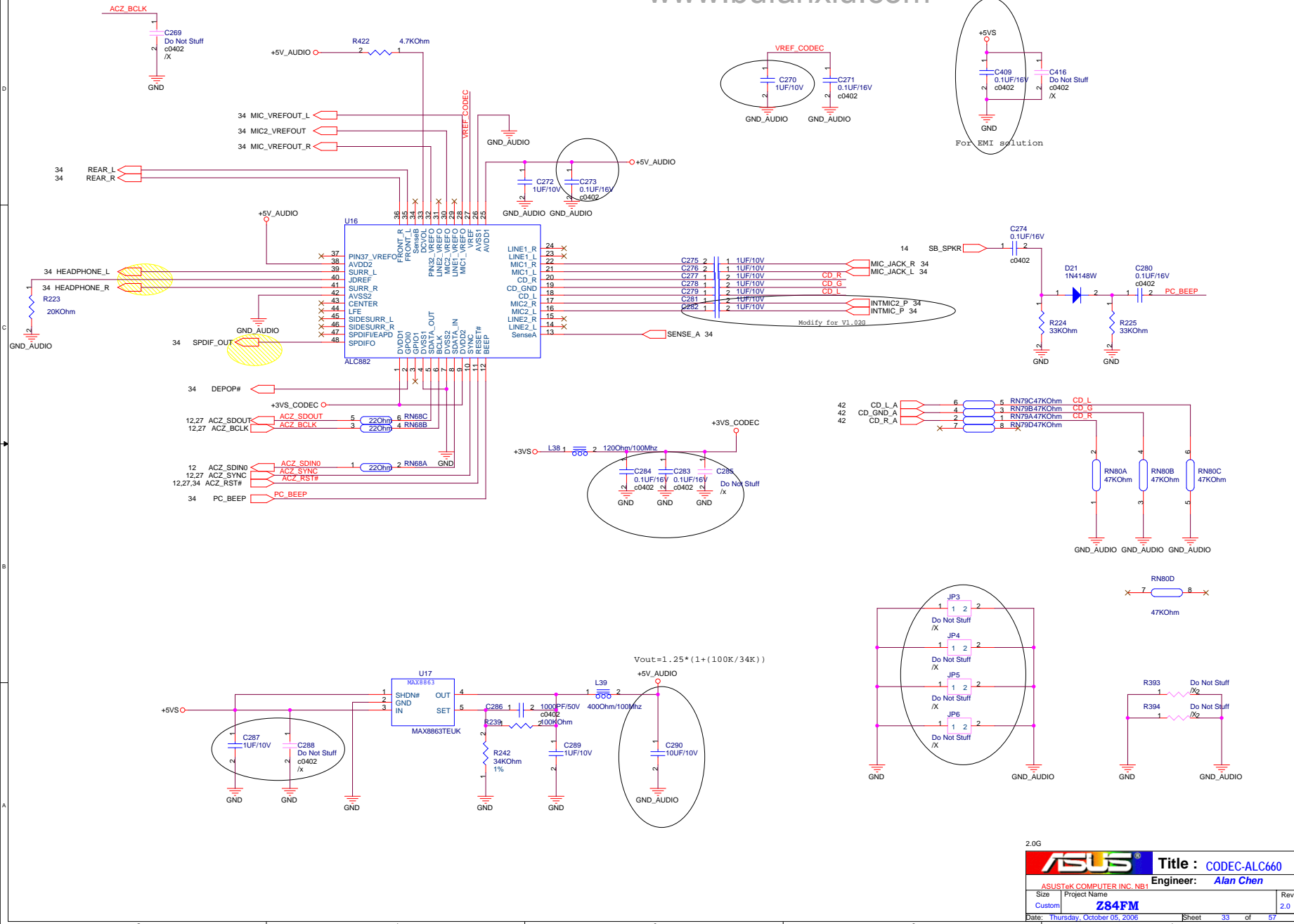

2.0G

<b>ASUS</b>		<b>Title :</b> CODEC-ALC660
ASUSTeK COMPUTER INC. NB1		<b>Engineer:</b> Alan Chen
Size	Project Name	Rev
Custom	<b>Z84FM</b>	2.0
Date: Thursday, October 05, 2006		Sheet 33 of 57



For EMI solution

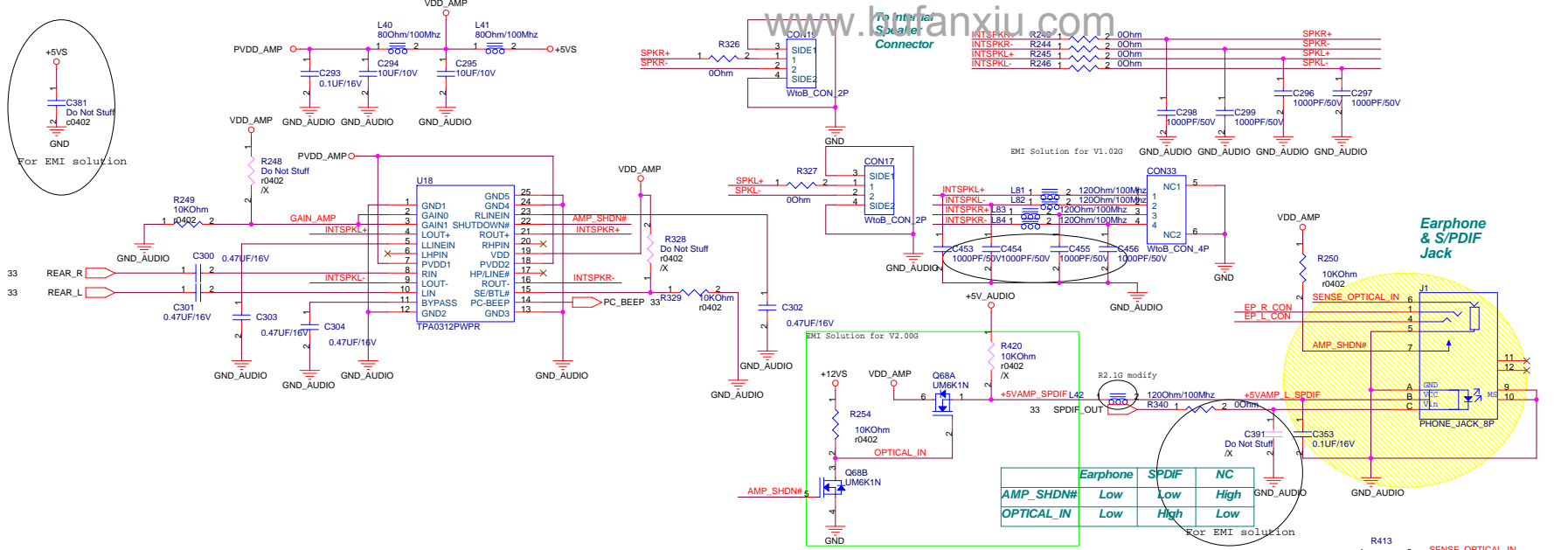

Earphone & SPDIF Jack

AMP_SHDN#	Low	Low	High
OPTICAL_IN	Low	High	Low

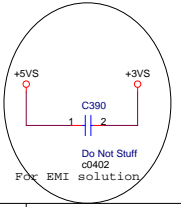
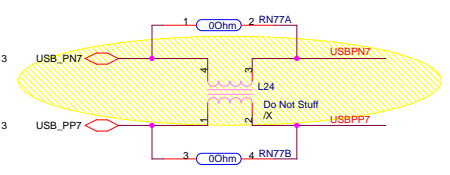
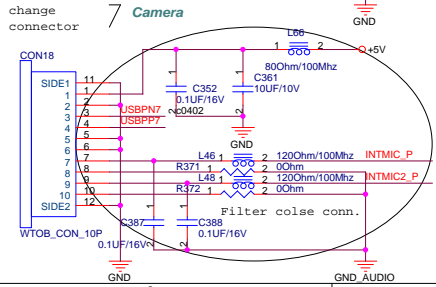
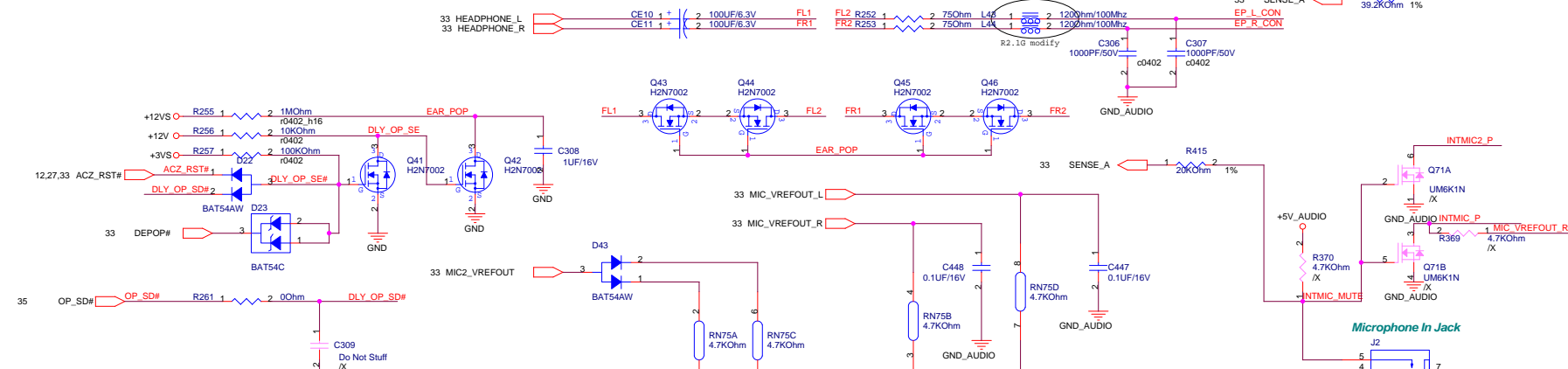

For EMI solution

**ASUS** Title : **AUDIO AMP & JACK**  
ASUSTek COMPUTER INC. NB1 Engineer: **Alan Chen**  
Size Project Name  
Custom **Z84FM**  
Date: Thursday, October 05, 2006 Sheet 34 of 57

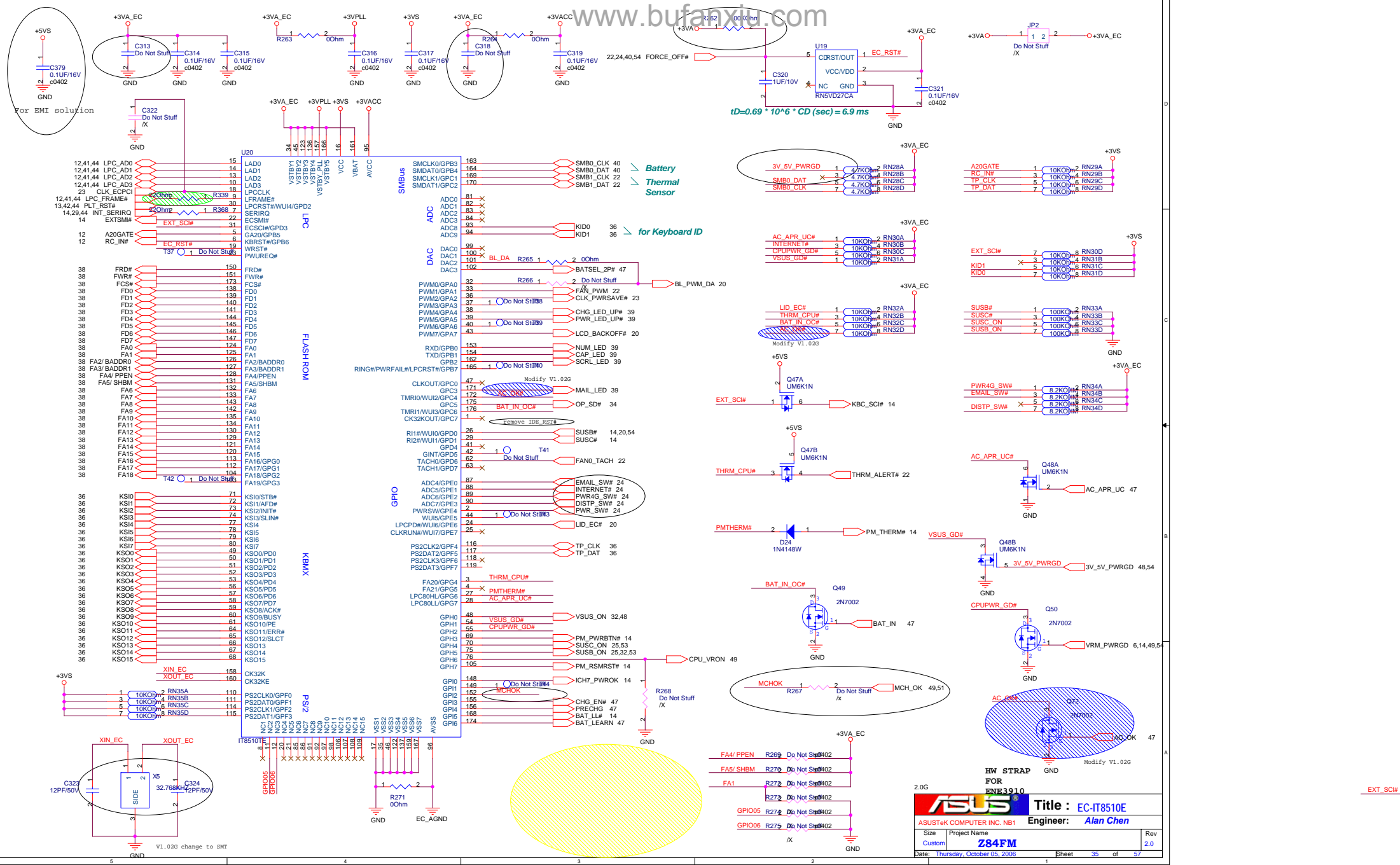

ASUS		Title : EC-IT8510E	
ASUSTeK COMPUTER INC. NB1		Engineer: Alan Chen	
Size	Project Name	Rev	
Custom	Z84FM	2.0	
Date: Thursday, October 05, 2006		Sheet 35 of 57	

### For Touch-Pad

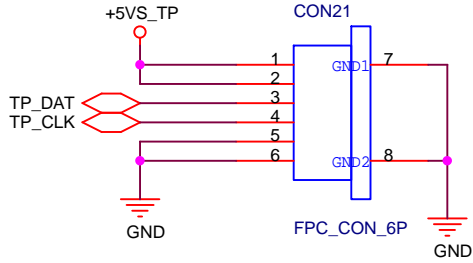
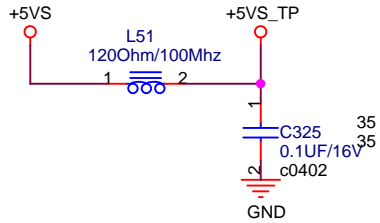

### For Keyboard

For CBB -US- MATRIX

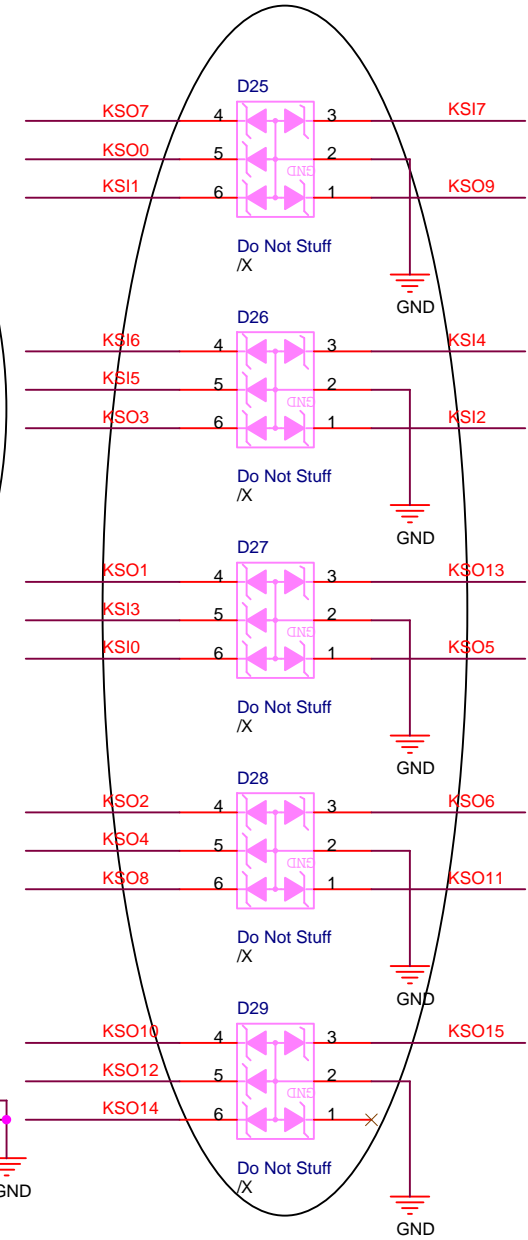
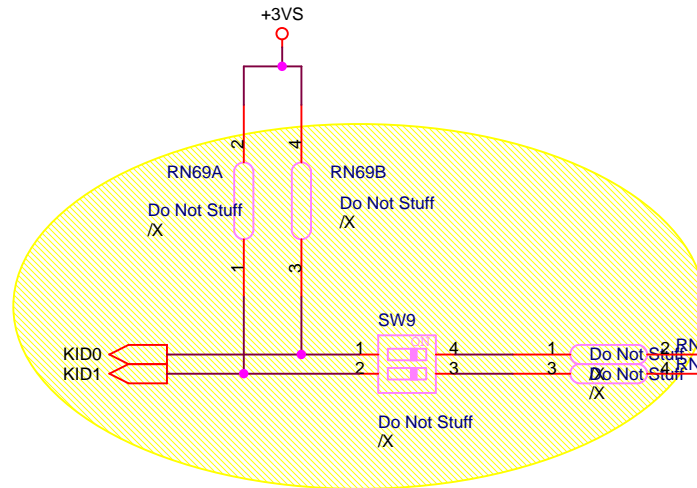
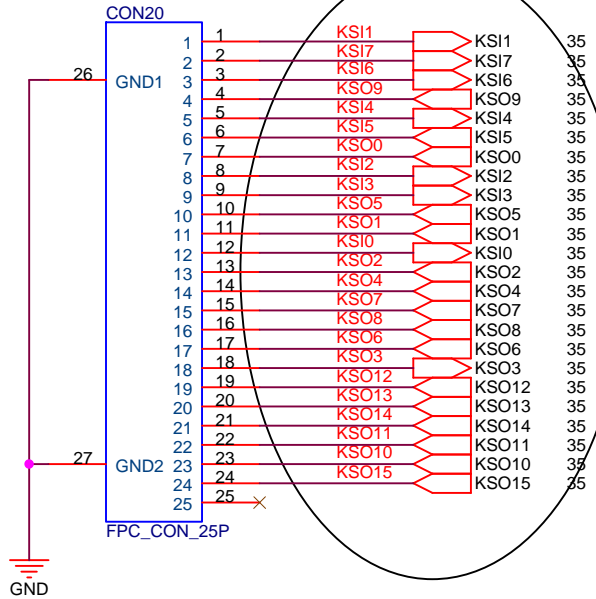

2.0G

D

C

B

A









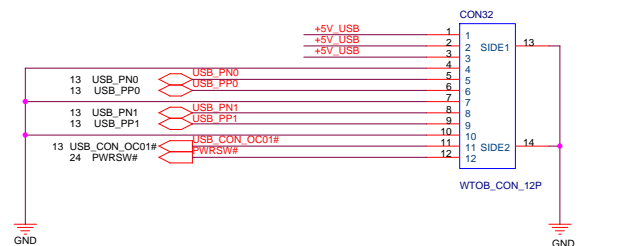
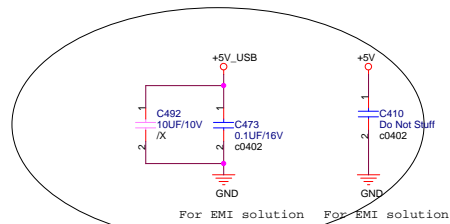
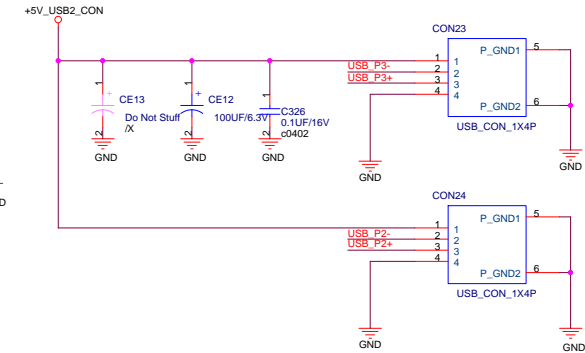
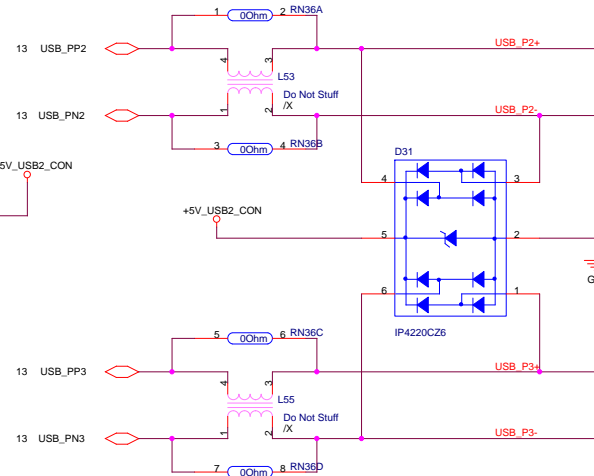
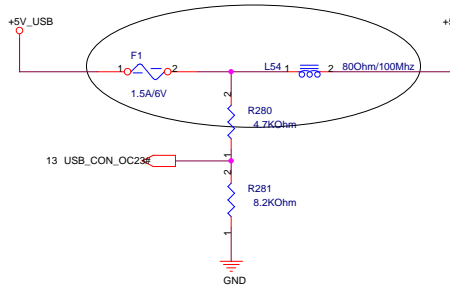
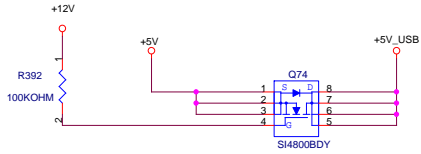
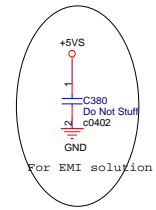

2.0G

<b>ASUS</b>		<b>Title : USB CONN</b>
ASUSTeK COMPUTER INC		Engineer: Alan Chen
Size	Project Name	Rev
Custom	<b>Z84FM</b>	2.0
Date: Thursday, October 05, 2006		Sheet 37 of 57

# ISA ROM

## EC Hardware Strapping

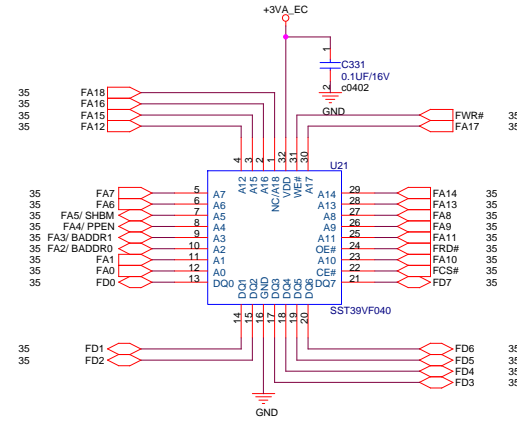
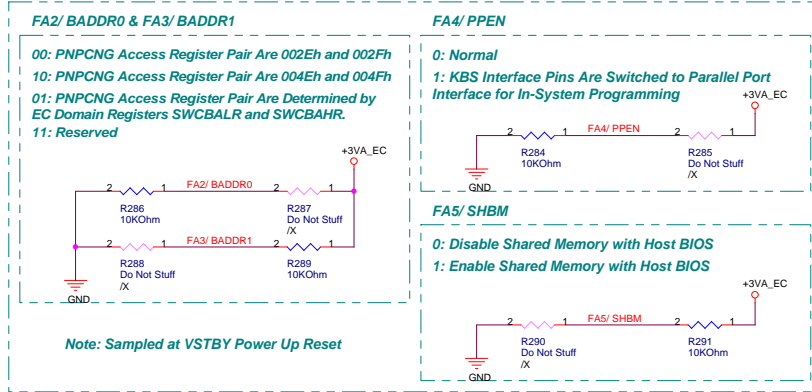

2.0G

		<b>Title :ISA ROM</b>
ASUSTeK COMPUTER INC. NB1		Engineer: <b>Alan Chen</b>
Size Custom	Project Name <b>Z84FM</b>	Rev <b>2.0</b>
Date: Thursday, October 05, 2006		Sheet 38 of 57

For POWER LED

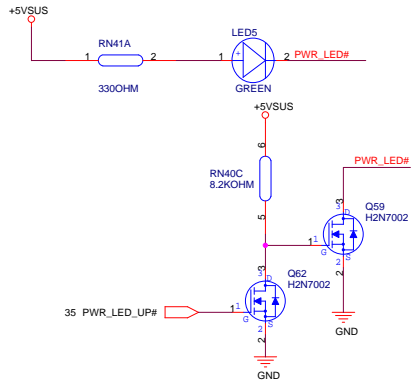

For BATTERY LED

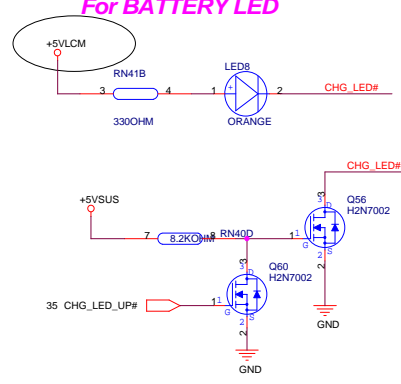

for EMIAL LED

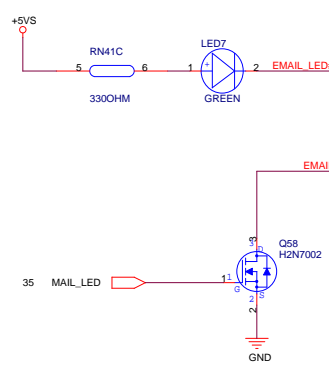

For WireLess LED

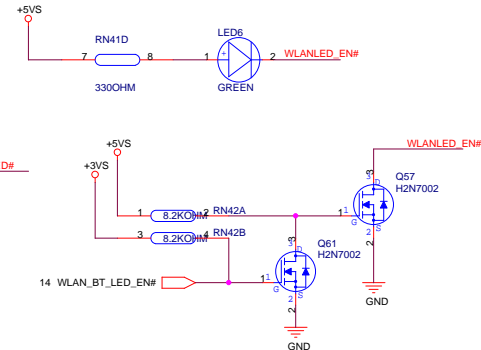

For ESATA/IDE LED

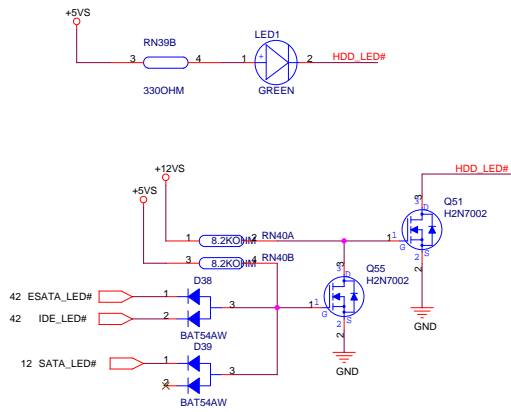

for Num Lock

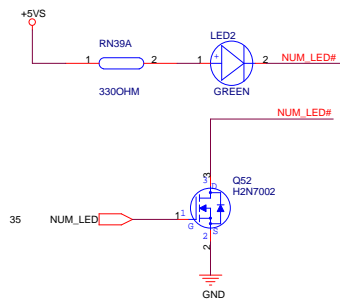

for Cap. Lock

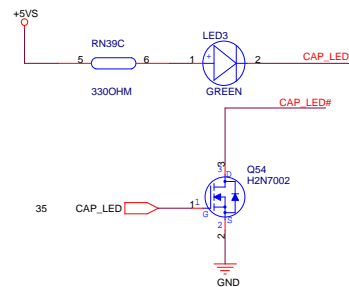

for Scroll Lock

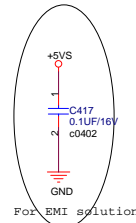
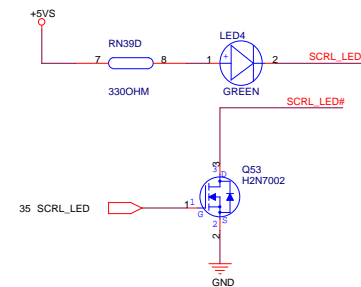

2.0G

<b>ASUS</b>		<b>Title : LED</b>	
ASUSTeK COMPUTER INC		Engineer: Alan Chen	
Size	Project Name	Rev	
Custom	<b>Z84FM</b>	2.0	
Date: Thursday, October 05, 2006		Sheet	39 of 57

DC IN

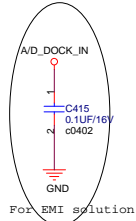
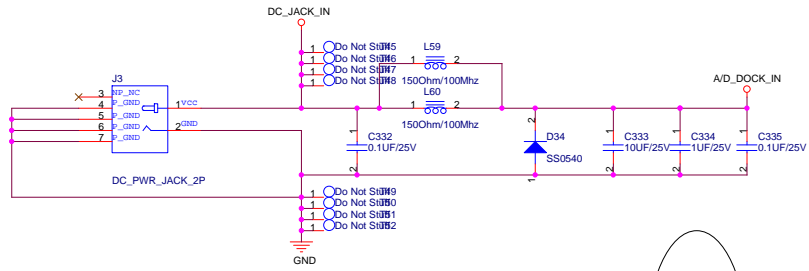

For EMI solution

remove AC DC detect; no need

BAT IN

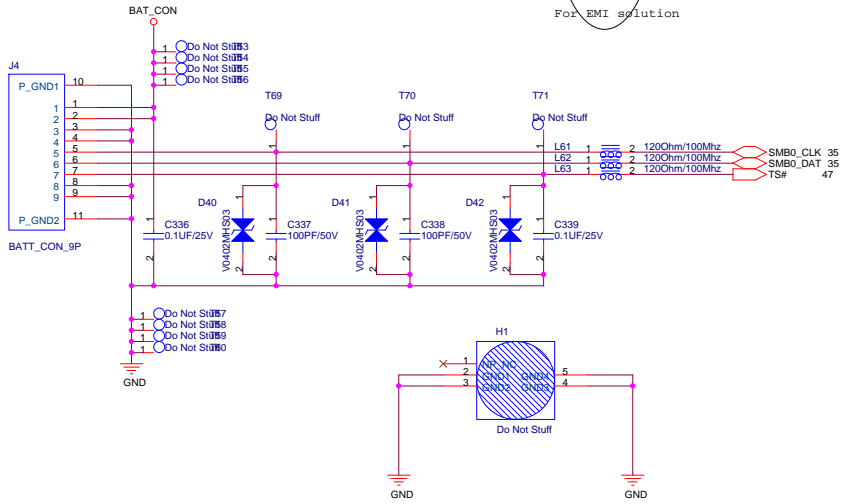

Without Battery & Pull out Adapter

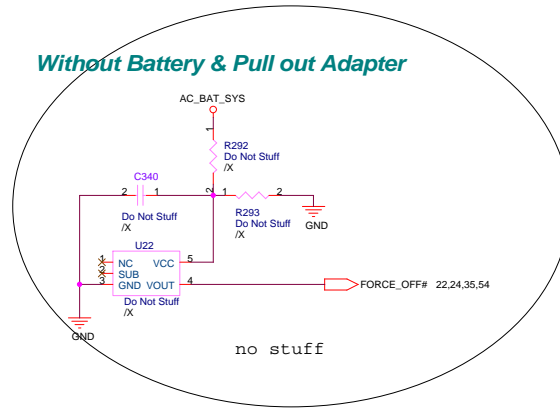

no stuff

2.0G

For Debug

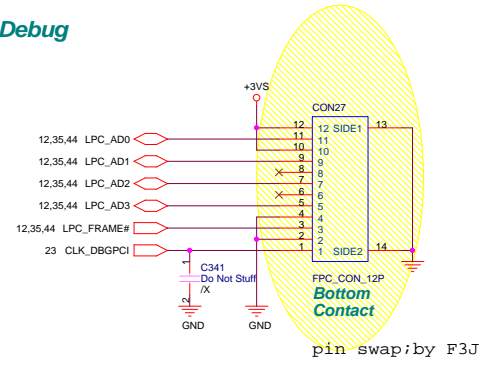
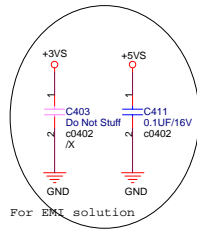

2.0G

		Title : Debug CONN.	
ASUSTeK COMPUTER INC		Engineer: Alan Chen	
Size	Project Name	Rev	
Custom	Z84FM	2.0	
Date: Thursday, October 05, 2006		Sheet	41 of 57





FOR LEFT UNDER

FOR FAN

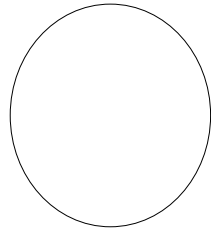
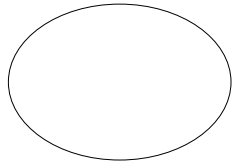

FOR RIGHT UP

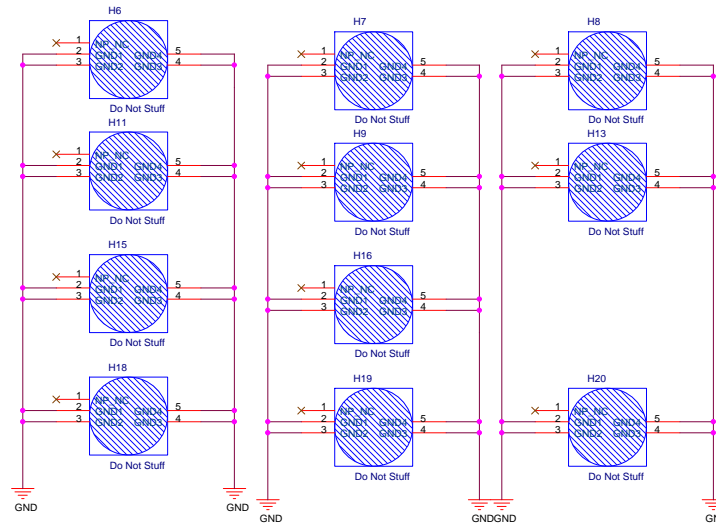
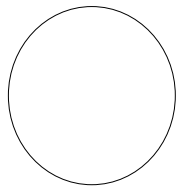

FOR SCREW HOLE

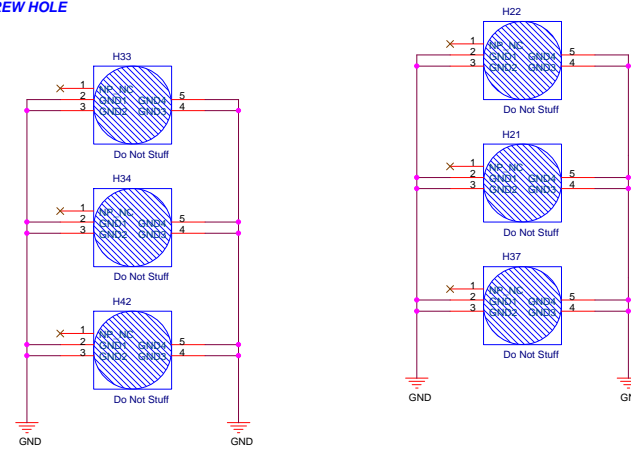

Non pth hole

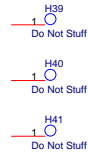

FOR CPU

FOR VGA

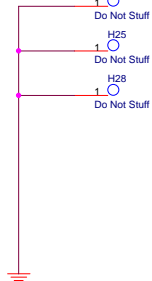
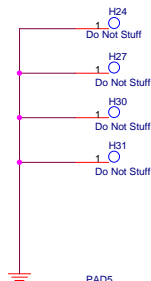

FOR FAN

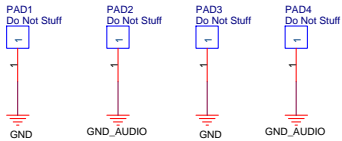
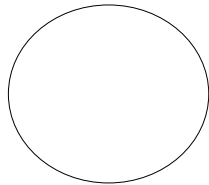

2.0G

<b>ASUS</b>		<b>Title :</b> SREW HOLE
ASUSTeK COMPUTER INC		<b>Engineer:</b> Alan Chen
Size	Project Name	Rev
Custom	<b>Z84FM</b>	2.0
Date: Thursday, October 05, 2006		Sheet 43 of 57

For TPM Module

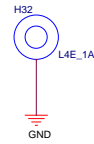
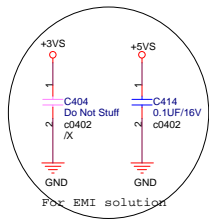
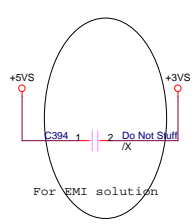
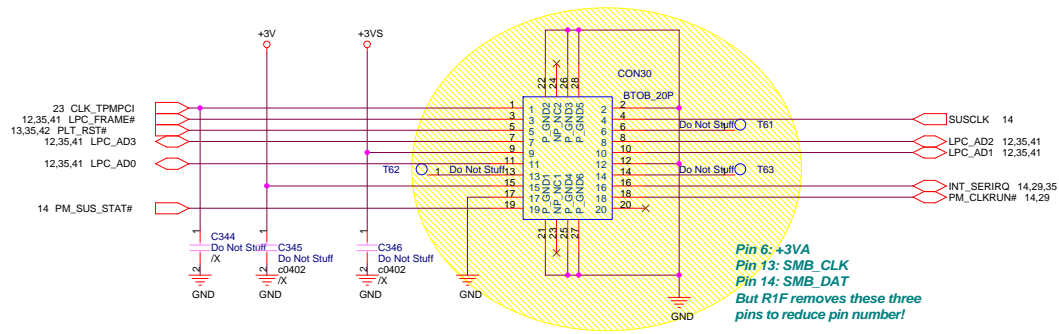

2.0G

<b>ASUS</b>		<b>Title : TPM</b>	
ASUSTeK COMPUTER INC		Engineer: Alan Chen	
Size	Project Name	Rev	
Custom	<b>Z84FM</b>	2.0	
Date: Thursday, October 05, 2006		Sheet	44 of 57

For Bluetooth

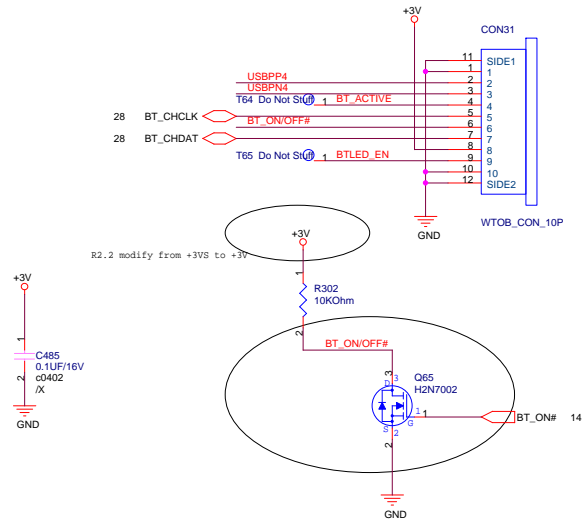

Remove Side SW

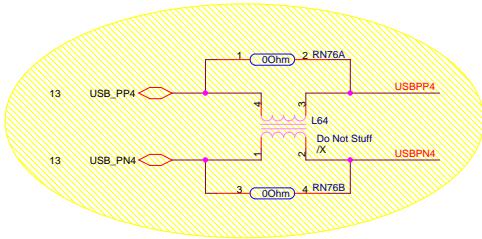

2.0G

<b>ASUS</b>		<b>Title :</b> Blue Tooth
ASUSTeK COMPUTER INC		<b>Engineer:</b> Alan Chen
Size	Project Name	Rev
Custom	<b>Z84FM</b>	2.0
Date: Thursday, October 05, 2006	Sheet	45 of 57

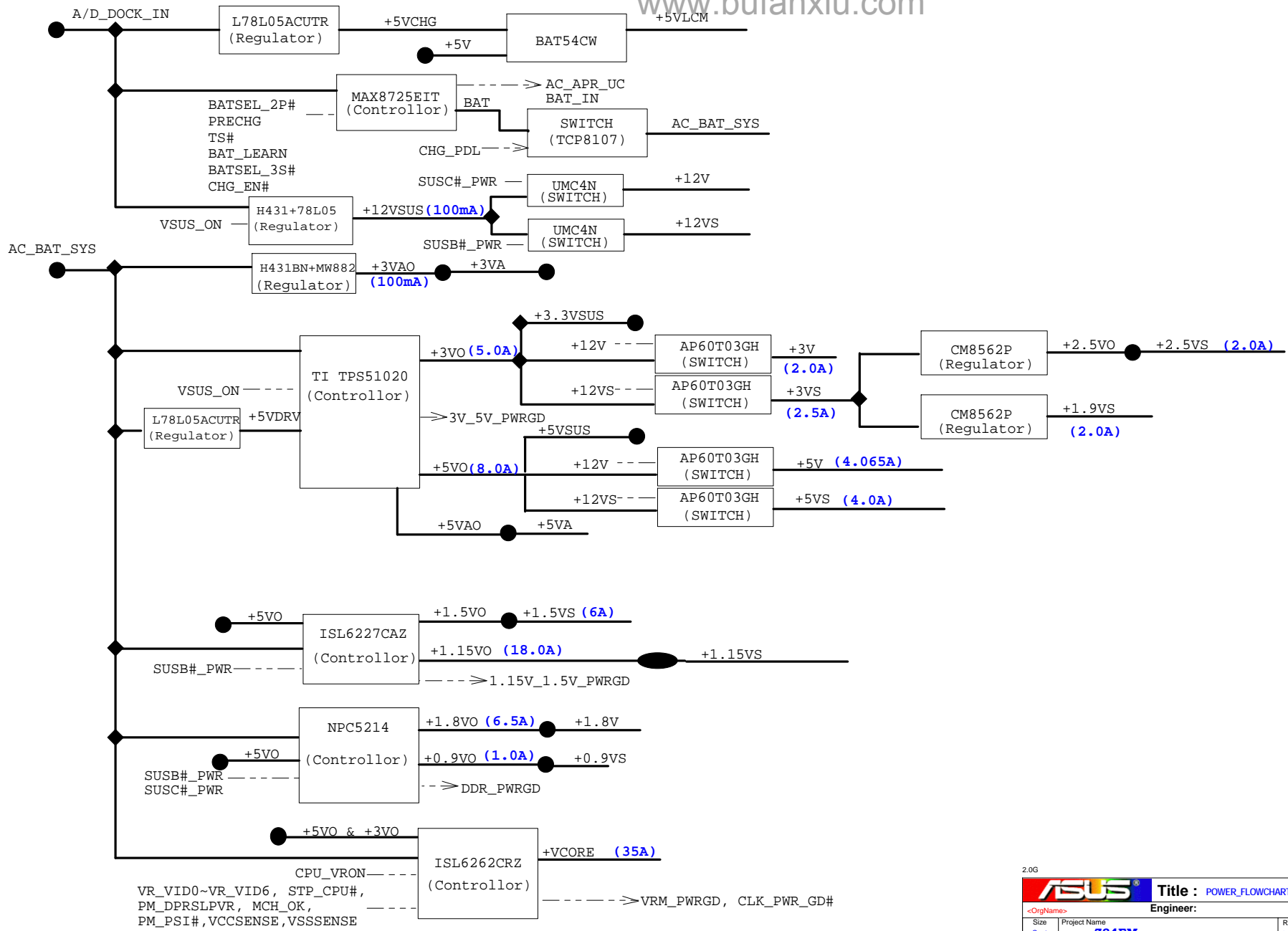

**Setting the Adapter Input Current Limit**  
 Adapter Iin(max) = [0.075V/Rsense(ADin)]\*[VCLS/VREF]  
 VCLS = 2.865V  
**Adaptor Max. Current:**  
 PR5718=20K PR5714 = 178K; Ilimit = 4.5A; 90W  
 PR5718=27K PR5714 = 47K; Ilimit = 3.175A; 60W

**Setting the Charge Voltage**  
 $V_{batt} = Cell * \{ V_{ref} + (V_{CTL} - 1.8V) / 9.52 \}$   
 VCTL = 1.588V => Vbatt = 4.2V

**Setting the Charge Current**  
 Charge Current Ichg = [0.075V/Rsense(CHG)]\*[VICTL/3.6V]  
 Rsense(CHG) = 15m Ohm  
**Pre-Charging Mode:**  
 Precharging current = 148 ~ 152mA  
 Vicitl = 0.107V ~ 0.109V

**Battery Cell Selection:**  
 BATSEL\_2P# = 1, 3 Cells; Vicitl = 2.084V  
 => Icharge = 1.6933A  
 BATSEL\_2P# = 0, 6 or 9 Cells; Vicitl = 2.111V  
 => Icharge = 2.9329A

**Mode pin:**  
 Vmode > 2.8V (try to LDO pin) -> 4 Cells  
 2.0 > Vmode > 1.6V (floating) -> 3 Cells  
 0.8 > Vmode (try to GND) -> Learning mode  
 VICTL < 0.8V or DCIN < 7V -> Charger Disable

MAX8725\_REF : 4.2235V  
 MAX8725\_LDO : 5.4V

### POWER PATH & BAT\_LEARN

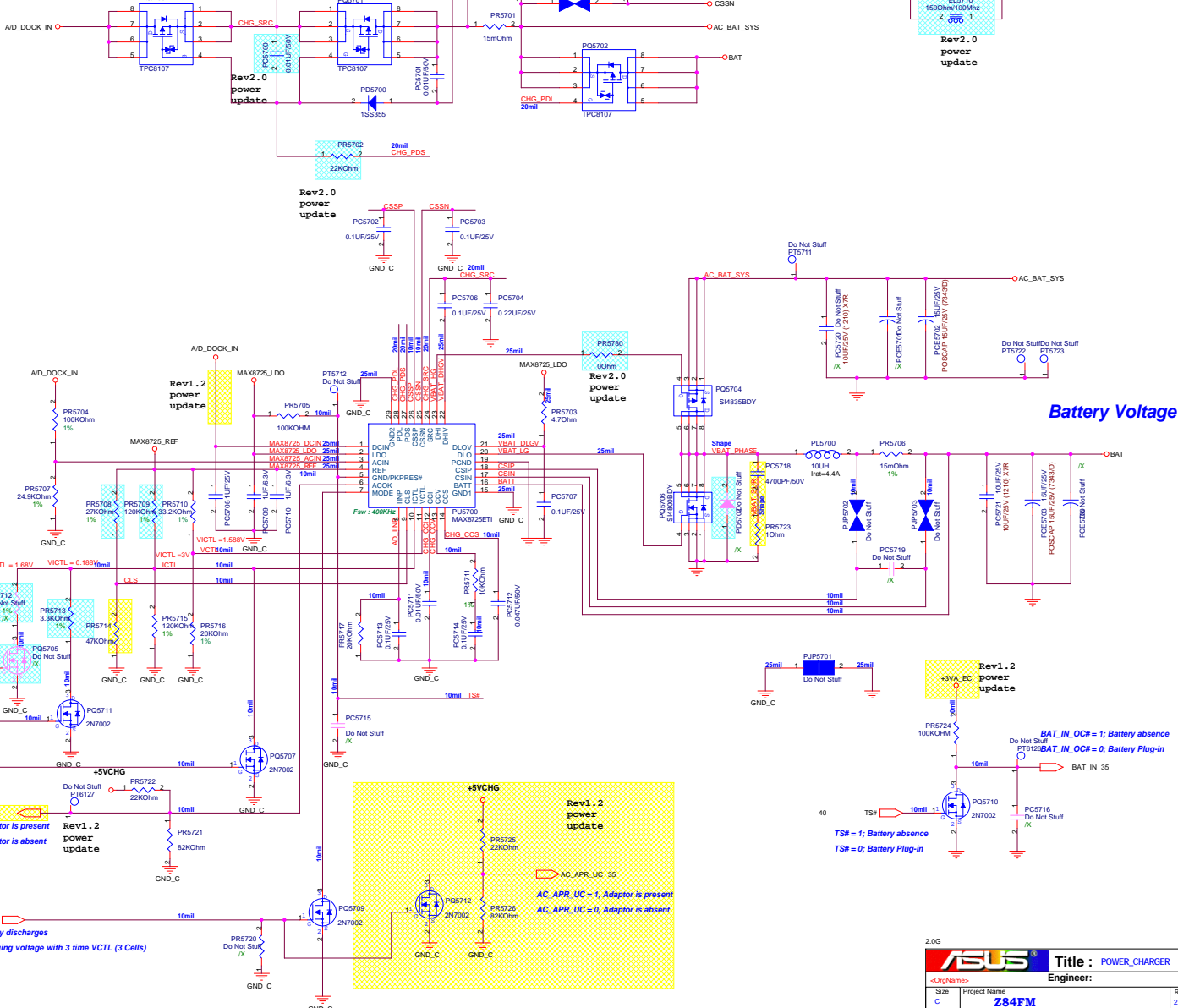

35 BATSEL\_2P#  
 BATSEL\_2P# = 1, 3 Cells  
 BATSEL\_2P# = 0, 6 or 9 Cells

35 PRECHG  
 PRECHG = 1, Pre-Charging Mode  
 Charging Current = 156mA

35 CHG\_EN#  
 CHG\_EN# = 1, Charger Disabled  
 CHG\_EN# = 0, Charger Enabled

35 AC\_OK  
 AC\_OK = 1, Adaptor is present  
 AC\_OK = 0, Adaptor is absent

35 BAT\_LEARN  
 BAT\_LEARN = 1, Battery discharges  
 BAT\_LEARN = 0, charging voltage with 3 time VCTL (3 Cells)

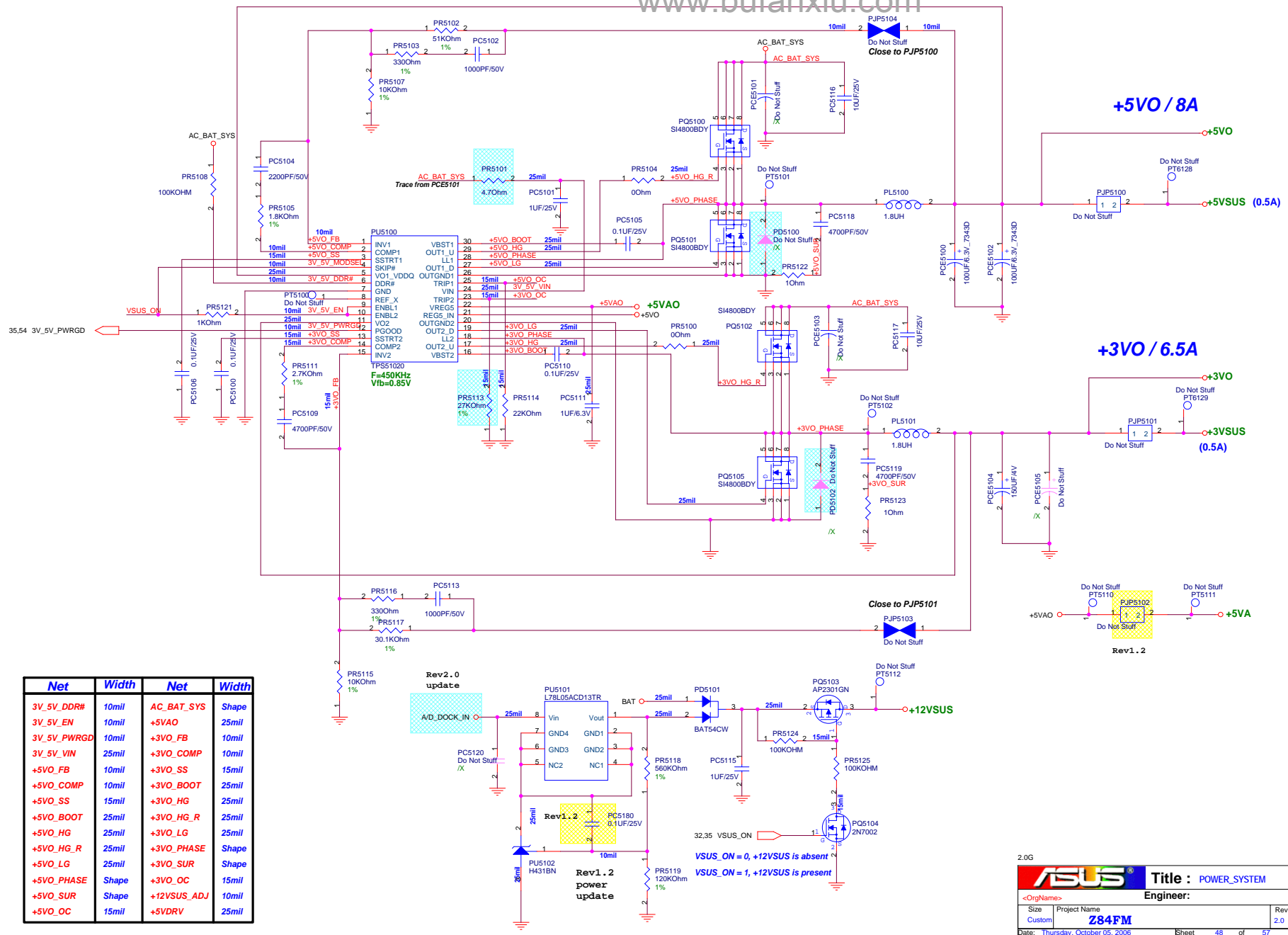

Net	Width	Net	Width
3V_5V_DDR#	10mil	AC_BAT_SYS	Shape
3V_5V_EN	10mil	+5VAO	25mil
3V_5V_PWRGD	10mil	+3VO_FB	10mil
3V_5V_VIN	25mil	+3VO_COMP	10mil
+5VO_FB	10mil	+3VO_SS	15mil
+5VO_COMP	10mil	+3VO_BOOT	25mil
+5VO_SS	15mil	+3VO_HG	25mil
+5VO_BOOT	25mil	+3VO_HG_R	25mil
+5VO_HG	25mil	+3VO_LG	25mil
+5VO_HG_R	25mil	+3VO_PHASE	Shape
+5VO_LG	25mil	+3VO_SUR	Shape
+5VO_PHASE	Shape	+3VO_OC	15mil
+5VO_SUR	Shape	+12VSUS_ADJ	10mil
+5VO_OC	15mil	+5VDRV	25mil

2.0G

**ASUS** Title : POWER\_SYSTEM

Engineer:

<OrgName>

Size Project Name

Custom **Z84FM**

Date: Thursday, October 05, 2006 Sheet 48 of 57

Rev 2.0

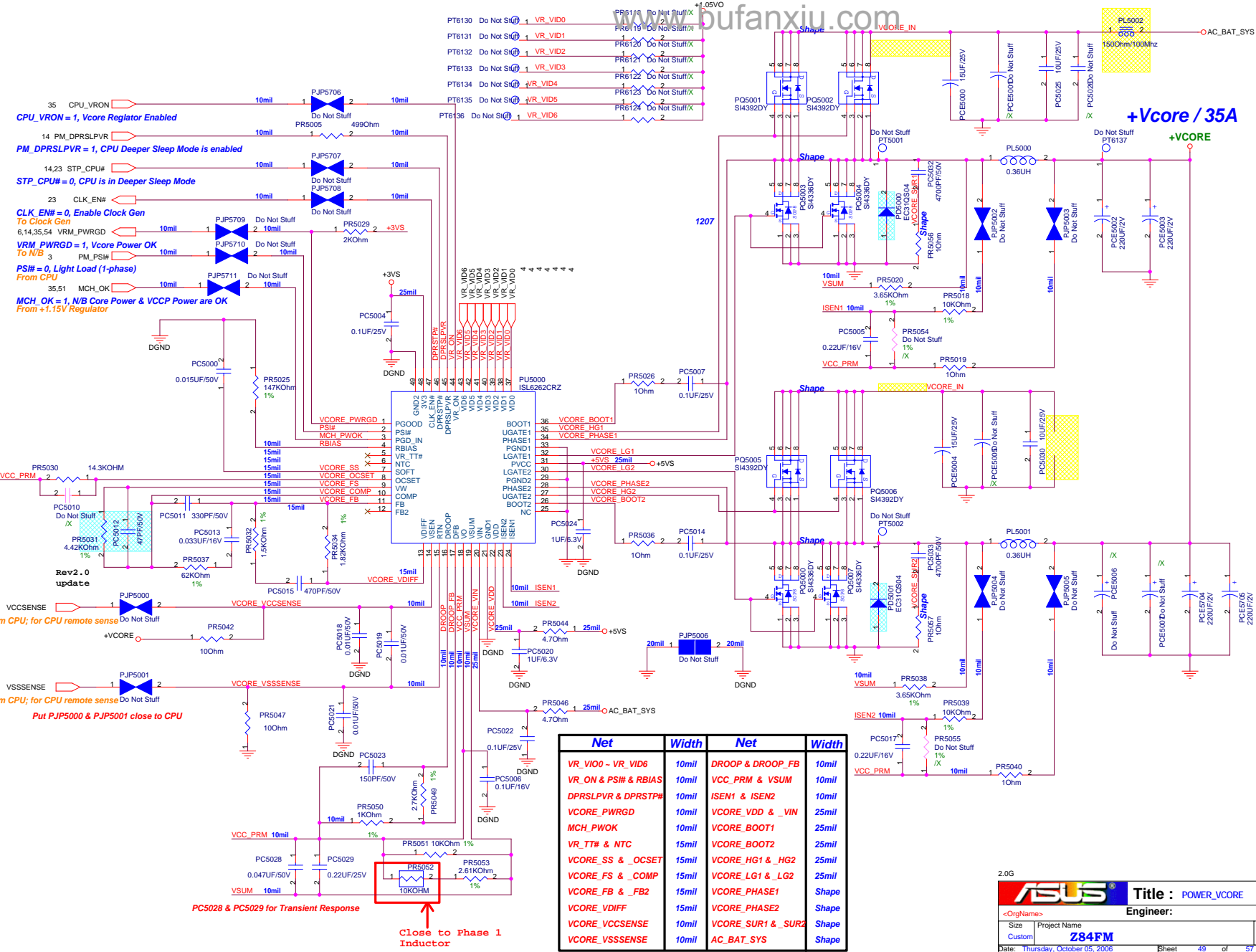

Net	Width	Net	Width
VR_VIO0 - VR_VID6	10mil	DROOP & DROOP_FB	10mil
VR_ON & PSH# & RBIAS	10mil	VCC_PRM & VSUM	10mil
DPRSLPVR & DPRSTPH	10mil	ISEN1 & ISEN2	10mil
Vcore_PWRGD	10mil	Vcore_VDD & _VIN	25mil
MCH_PWOK	10mil	Vcore_BOOT1	25mil
VR_TT# & NTC	15mil	Vcore_BOOT2	25mil
Vcore_SS & _OCSET	15mil	Vcore_HG1 & _HG2	25mil
Vcore_FS & _COMP	15mil	Vcore_LG1 & _LG2	25mil
Vcore_FB & _FB2	15mil	Vcore_PHASE1	Shape
Vcore_VDIFF	15mil	Vcore_PHASE2	Shape
Vcore_VCCSENSE	10mil	Vcore_SUR1 & _SUR2	Shape
Vcore_VSSSENSE	10mil	AC_BAT_SYS	Shape

2.0G

**ASUS** Title : POWER\_VCORE

Engineer:

Size Project Name  
 Custom Z84FM

Date: Thursday, October 05, 2006 Sheet 49 of 57

PC5028 & PC5029 for Transient Response

Close to Phase 1 Inductor

35 CPU\_VRON = 1, Vcore Regulator Enabled

14 PM\_DPRSLPVR = 1, CPU Deeper Sleep Mode is enabled

14,23 STP\_CPU# = 0, CPU is in Deeper Sleep Mode

23 CLK\_EN# = 0, Enable Clock Gen To Clock Gen

6,14,35,54 VRM\_PWRGD = 1, Vcore Power OK To N/B

3 PM\_PSH# = 0, Light Load (1-phase) From CPU

35,51 MCH\_OK = 1, N/B Core Power & VCCP Power are OK From +1.15V Regulator

VCCSENSE From CPU; for CPU remote sense

VSSSENSE From CPU; for CPU remote sense

Put PJP5000 & PJP5001 close to CPU

Close to Phase 1 Inductor

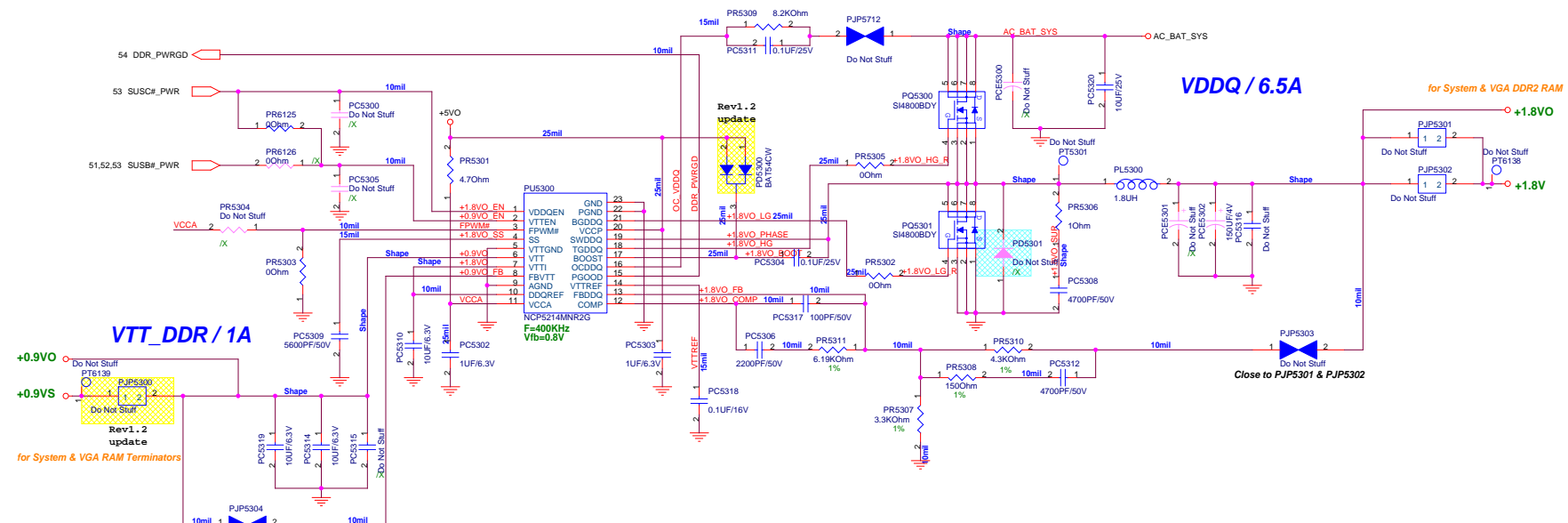

Net	Width	Net	Width
+1.8V_EN	10mil	+1.8V_BOOT	25mil
+1.8V	Shape	+1.8V_COMP	10mil
+0.9V_EN	10mil	+1.8V_HG_R	25mil
+0.9V	Shape	+1.8V_LG_R	25mil
+0.9V_FB	10mil	+1.8V_HG	25mil
+1.8V -> DDQREF	10mil	+1.8V_LG	25mil
VTTREF	15mil	+1.8V_PHASE	Shape
FPWM#	10mil	+1.8V_SUR	Shape
VCCA	10mil	+1.8V_FB	10mil
DDR_PWRGD	10mil	+1.8V_SS	15mil
OC_VDDQ	15mil	AC_BAT_SYS	Shape

2.0G

**ASUS** Title : POWER\_IO\_DDR & VTT  
 Engineer:

<OrigName>	Project Name	Rev
Custom	<b>Z84FM</b>	2.0
Date: Thursday, October 05, 2006	Sheet	50 of 57



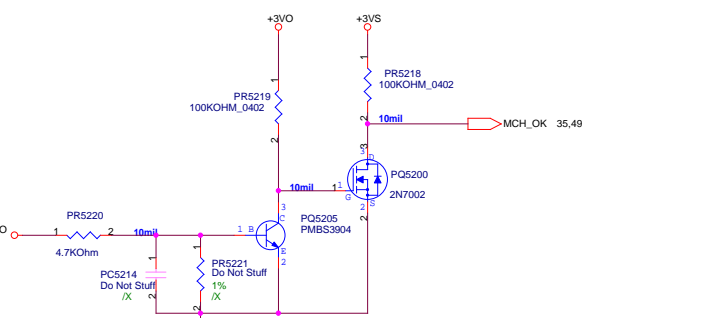
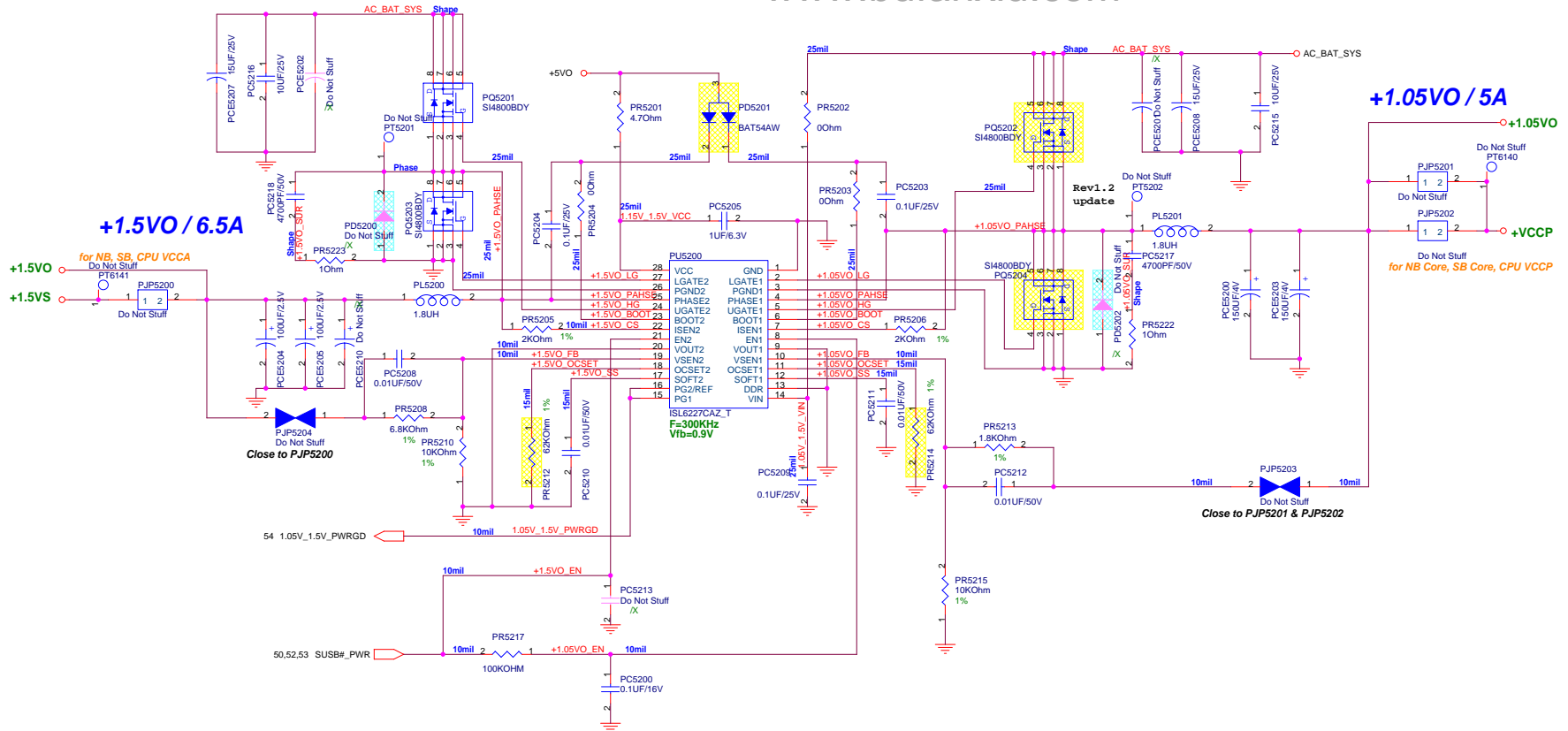

Net	Width	Net	Width
1.15V_1.5V_VCC	25mil	+1.5V0_SS	15mil
1.15V_1.5V_PWRGD	10mil	AC_BAT_SYS	Shape
1.15V_1.5V_VIN	25mil	+1.15V0_LG	10mil
+1.5V0_EN	10mil	+1.15V0_LG	25mil
+1.5V0_LG	25mil	+1.15V0_HG	25mil
+1.5V0_HG	25mil	+1.15V0_PHASE	Shape
+1.5V0_PHASE	Shape	+1.15V0_BOOT	25mil
+1.5V0_BOOT	25mil	+1.15V0_MODSEL	10mil
+1.5V0_MODSEL	10mil	+1.15V0_CS	10mil
+1.5V0_CS	10mil	+1.15V0_FB	10mil
+1.5V0_FB	10mil	+1.15V0_OCSET	25mil
+1.5V0_OCSET	15mil	+1.15V0_SS	15mil
+1.5V0_SUR	Shape	+1.15V0_SUR	Shape

2.0G

**ASUS** Title :POWER\_I0\_15VS & 1.05VS

Engineer:

Size Project Name

Custom **Z84FM**

Date: Thursday, October 05, 2006 Sheet 51 of 57

Rev 2.0

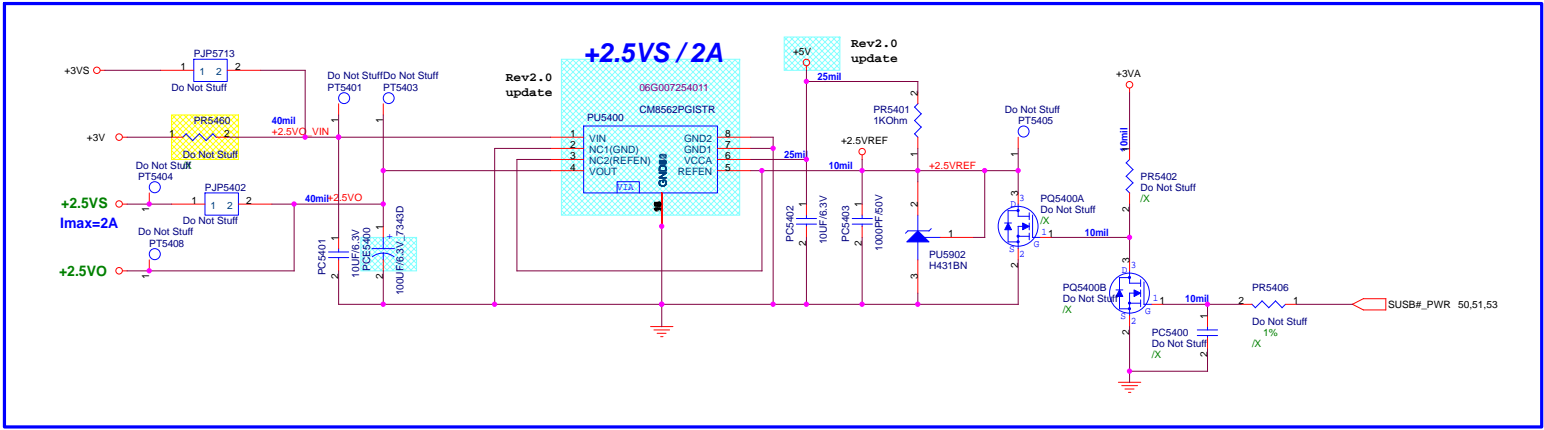
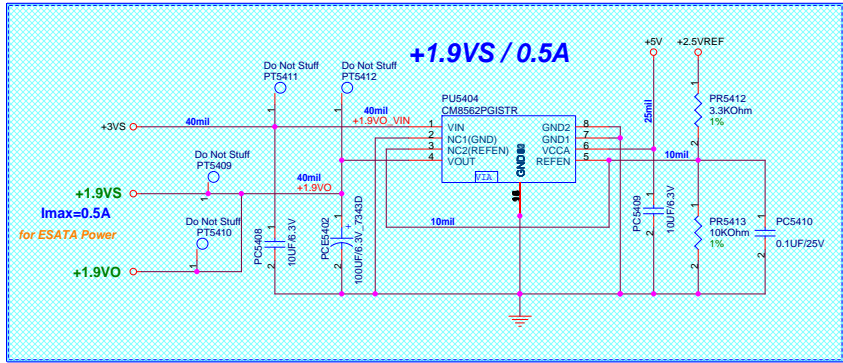
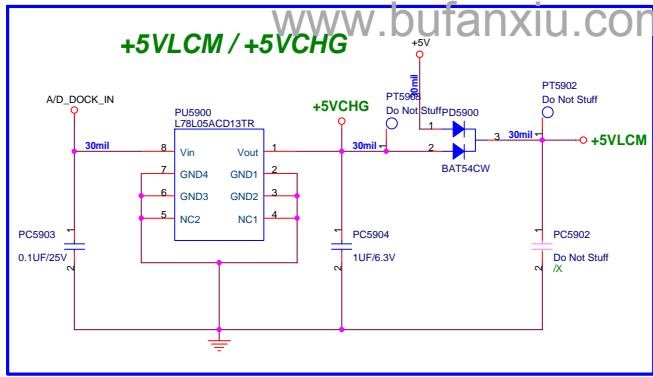
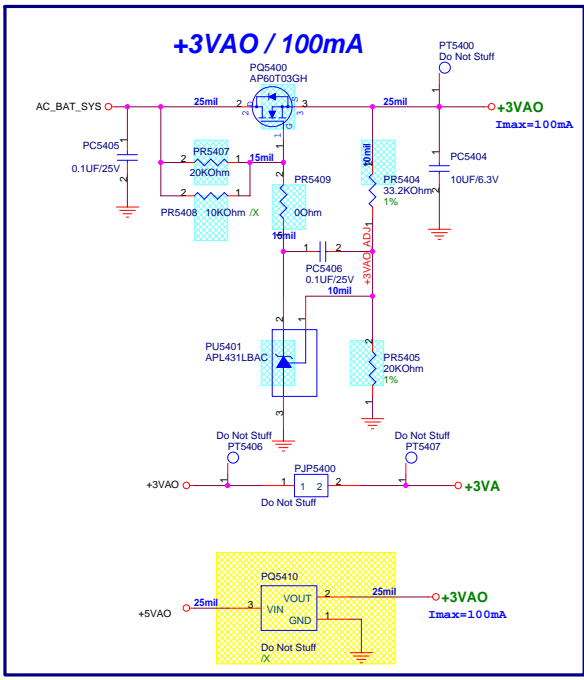

### SUSC#\_PWR POWER

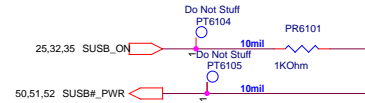
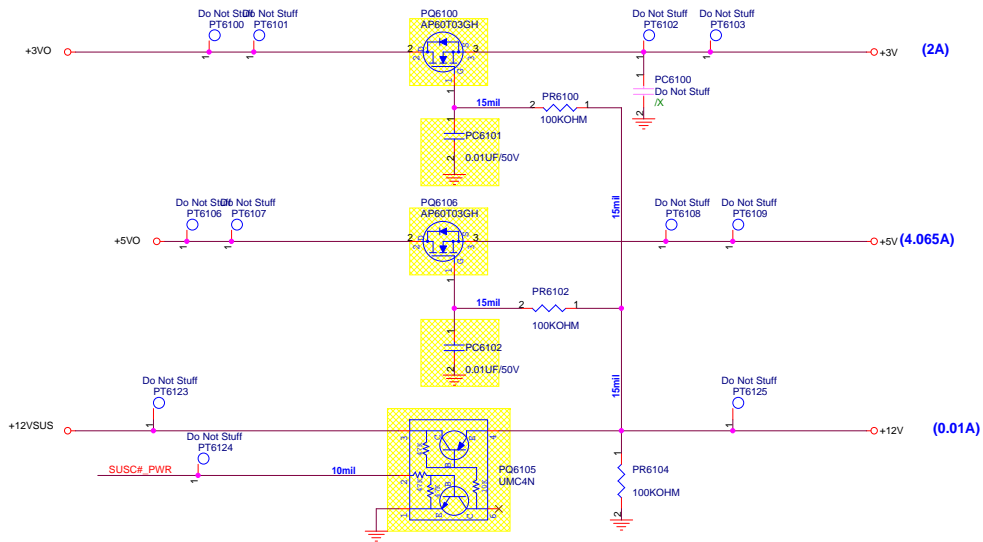

### SUSB#\_PWR POWER

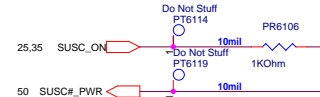
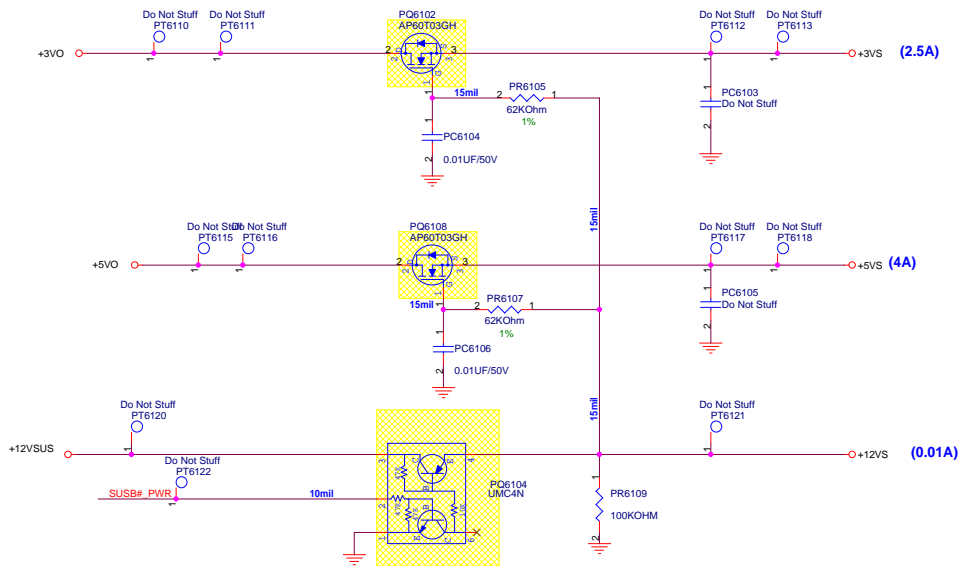

2.0G

<b>ASUS</b>		<b>Title : POWER_LOAD SWITCH</b>
Engineer:		
<OrgName>	Project Name	Rev
Custom	<b>Z84FM</b>	2.0
Date: Thursday, October 05, 2006	Sheet	53 of 57

### Power Good Detector

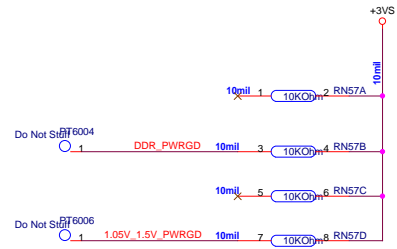
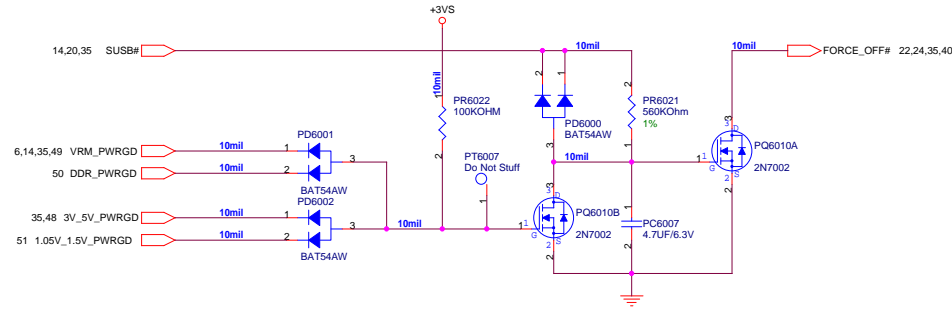

2.0G

<b>ASUS</b>		<b>Title : POWER_PROTECT</b>
<b>Engineer:</b>		
<b>&lt;OrgName&gt;</b>	<b>Project Name</b>	<b>Rev</b>
Size Custom	<b>Z84FM</b>	2.0
Date: Thursday, October 05, 2006	Sheet	54 of 57

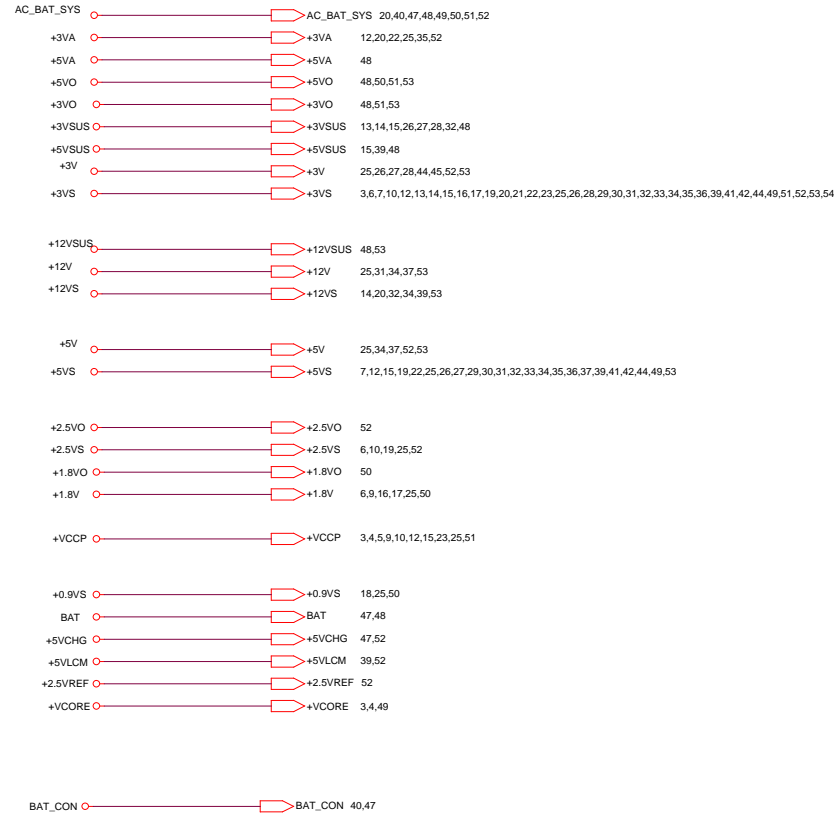

2.0G

		Title : POWER_SIGNAL	
<OrgName>		Engineer:	
Size	Project Name	Rev	
Custom	Z84FM	2.0	
Date: Thursday, October 05, 2006	Sheet	55	of 57



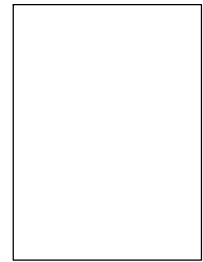
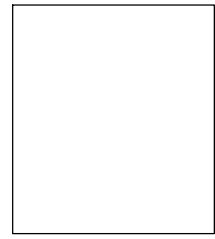
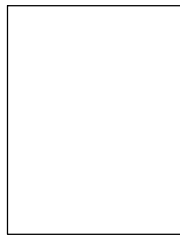
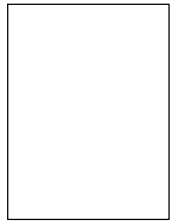
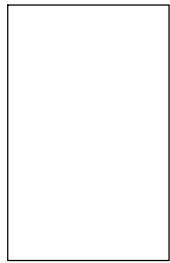

2.0G

		Title : <Title>	
ASUSTeK COMPUTER INC		Engineer: Alan Chu	
Size A3	Project Name <b>Z84FM</b>	Rev 2.0	
Date: Thursday, October 05, 2006		Sheet	57 of 57







[www.bufanxiu.com](http://www.bufanxiu.com)

