

5 4 3 2

Z94 SCHEMATICS : MAIN BOARD REV 1.1

www.bufanxiu.com



- P.01--INDEX (THIS PAGE)
- P.02--BLOCK DIAGRAM
- P.03--Pentium-M SOCKET479 - 1
- P.04--Pentium-M SOCKET479 - 2
- P.05--CLOCK GEN ICS950816
- P.06--SISM661MX (1) HOST/AGP
- P.07--SISM661MX (2) DDR/VGA/ZIP
- P.08--SISM661MX (3) PWR
- P.09--DDR Memory DIMM
- P.10--DDR Bypass & Driver
- P.11--VGA_Connector
- P.12--CRT Connector
- P.13--SIS964L - 1 PCI/ZIP/IDE
- P.14--SIS964L - 2 LPC/GPIO/AC97
- P.15--SIS964L - 3 USB/PWR
- P.16--HDD & CDROM CONN/USB
- P.17--LAN_RTL8201BL
- P.18--CardBus (1)
- P.19--CardBus (2)
- P.20--Debug Port & Hole & EMI
- P.21--Switch & MDC
- P.22--PortBar & FWH
- P.23--FAN controller
- P.24--KBC_KB38857
- P.25--Super I/O
- P.26--Audio Codec
- P.27--Audio AMP/JACK
- P.28--Power Sequence
- P.29--2.5V/1.8V/1.5V/1.25V
- P.30--SYSTEM_3V/5V
- P.31--BATLOW/SD#/DCIN
- P.32--CHARGER
- P.33--PIC16C54/BAT_IN
- P.34--Vcore
- P.35--VCCP_1.05V
- P.36--GPIO LIST
- P.37--POWER FLOW
- P.38--History

Power Sequence
 1) Power On Button
 2) System Power On
 3) System Power OK
 4) CPU VID & VCORE On
 5) CPU Power Good

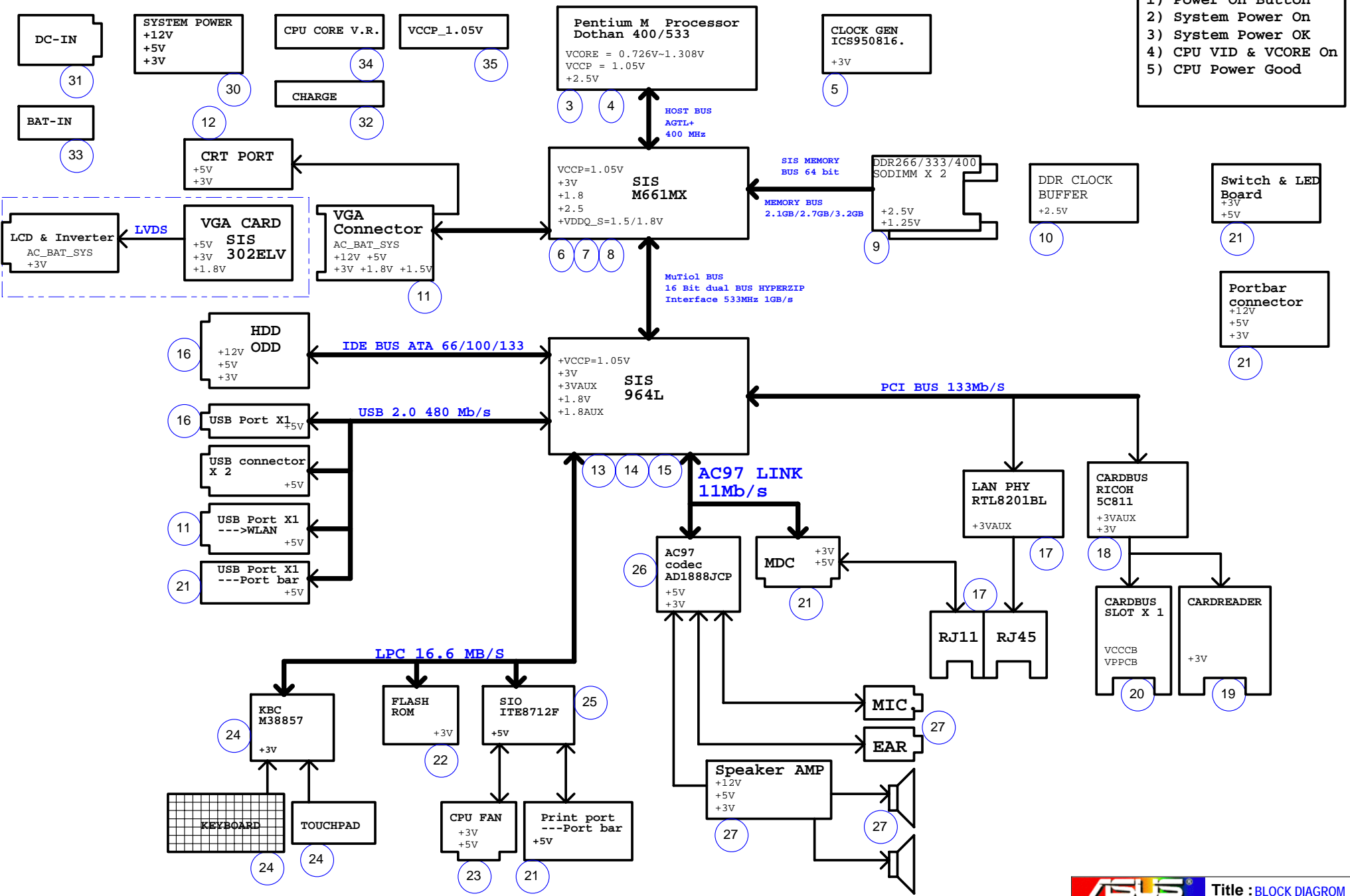

CPU Pin A1 need to be enlarged(M)

www.buifanxiu.com

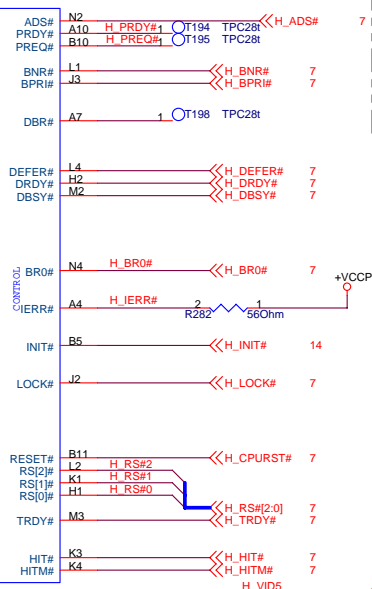
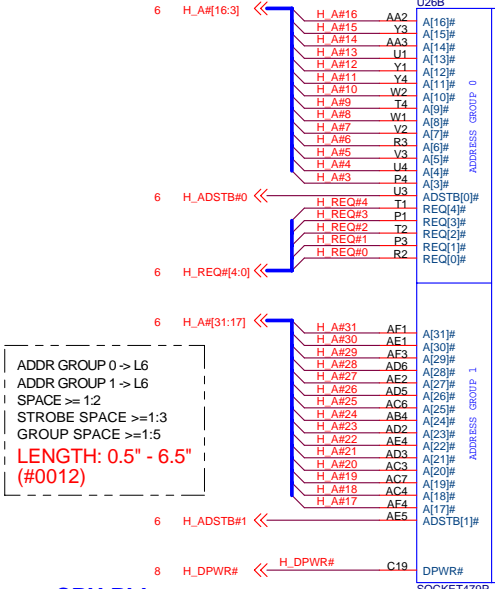

COMMON CLOCK -> L6
 WIDTH: 5 mils
 SPACE = 1.2
 GROUP SPACE >=1.5
 LENGTH: 1" - 6.5"(OPT: 4"+/-0.5")
 Breakout Length:<=200 mil (#001)

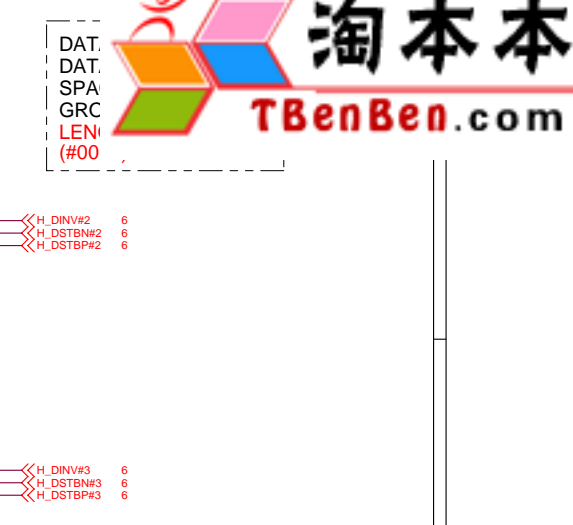
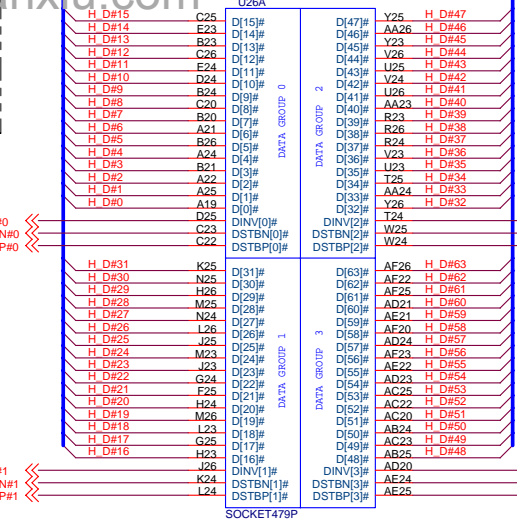

ADDR GROUP 0 -> L6
ADDR GROUP 1 -> L6
 SPACE >= 1.2
 STROBE SPACE >=1.3
 GROUP SPACE >=1.5
 LENGTH: 0.5" - 6.5" (#0012)

CPU PLL CIRCUITS

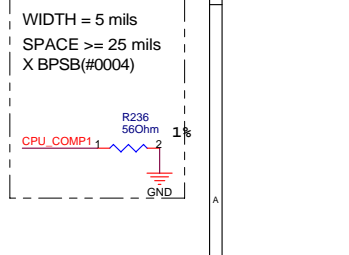
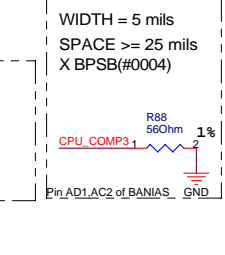
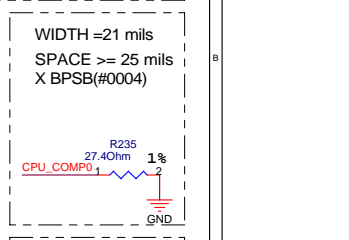
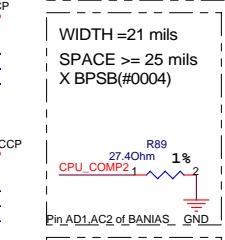
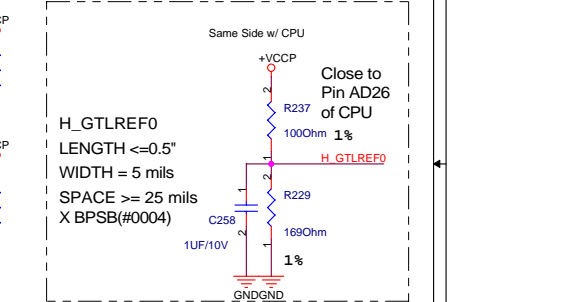
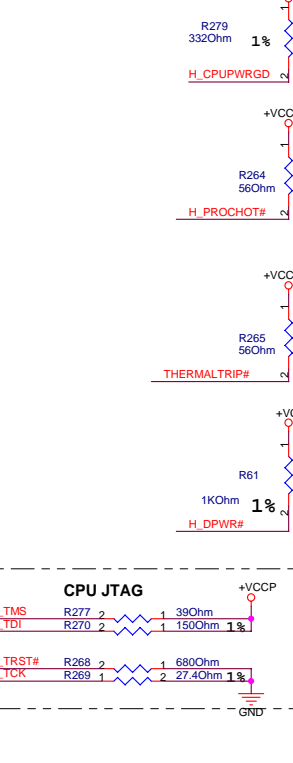
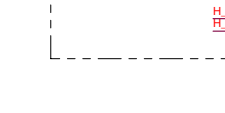
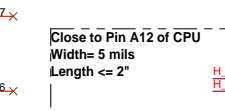
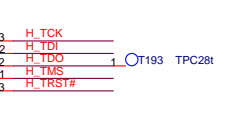
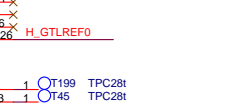
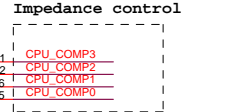
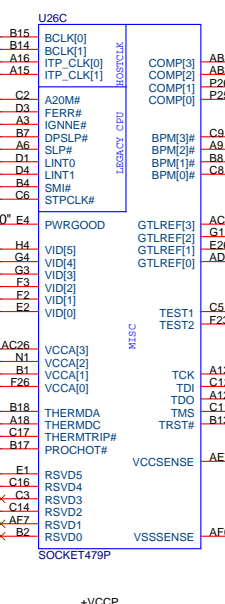
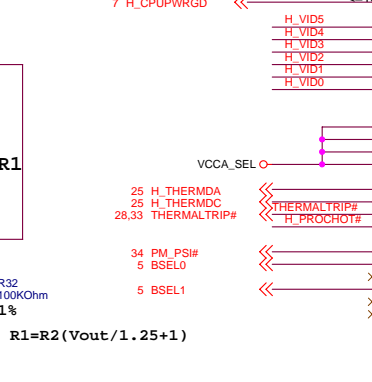
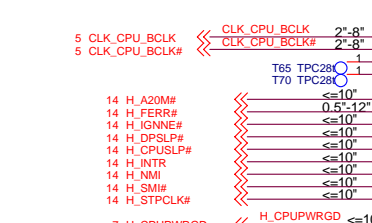
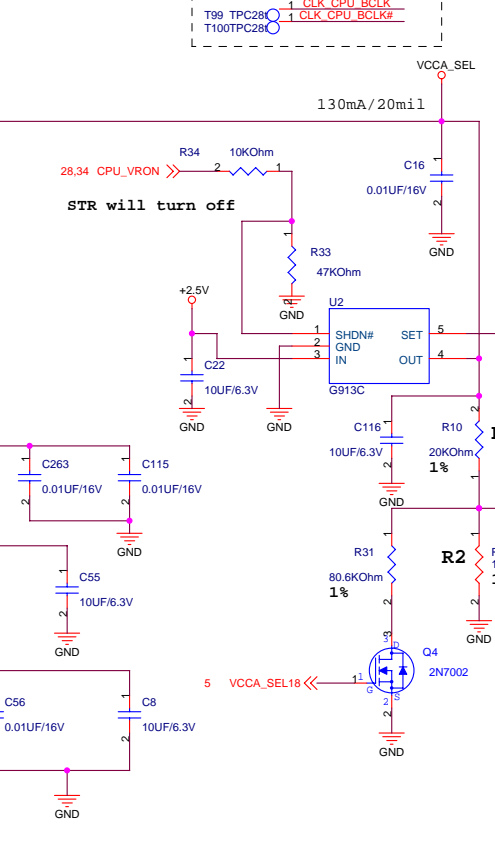

HFM(1.6GHz-2.13GHz): 0.726V - 1.308V(+/- 1.5%)
 1.308V C0: 23.1 A
 LFM(800MHz): C3: 8.9A
 0.988V C4: 3.7A

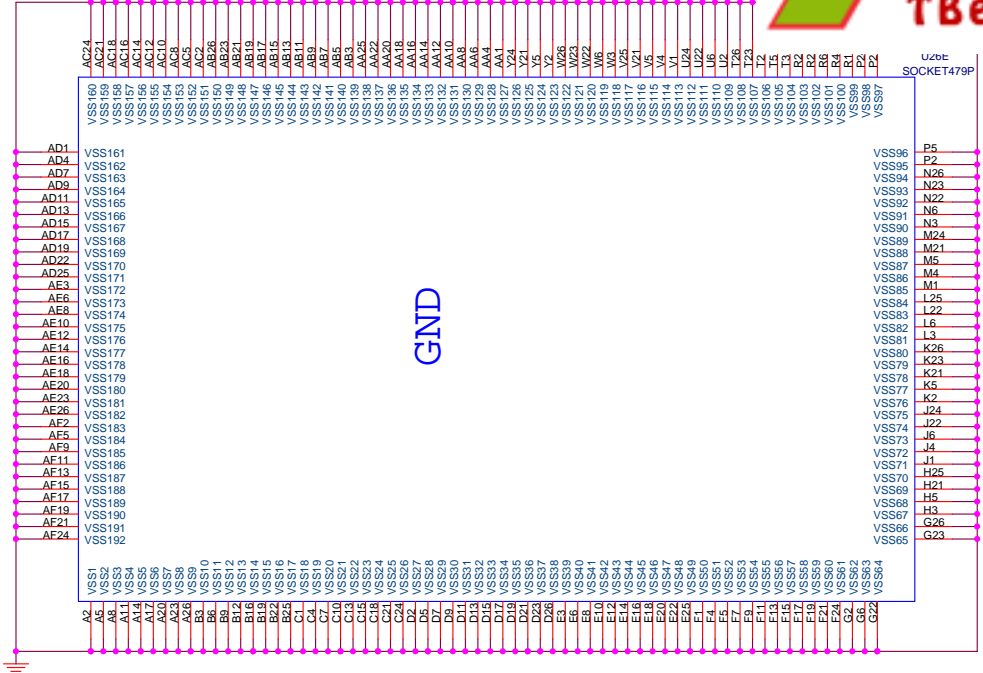
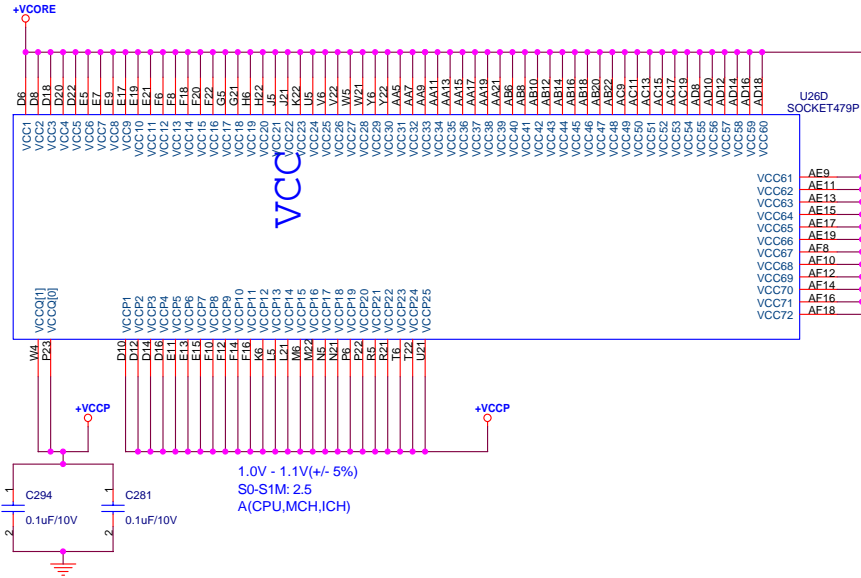

CPU VCORE Decoupling Capacitor

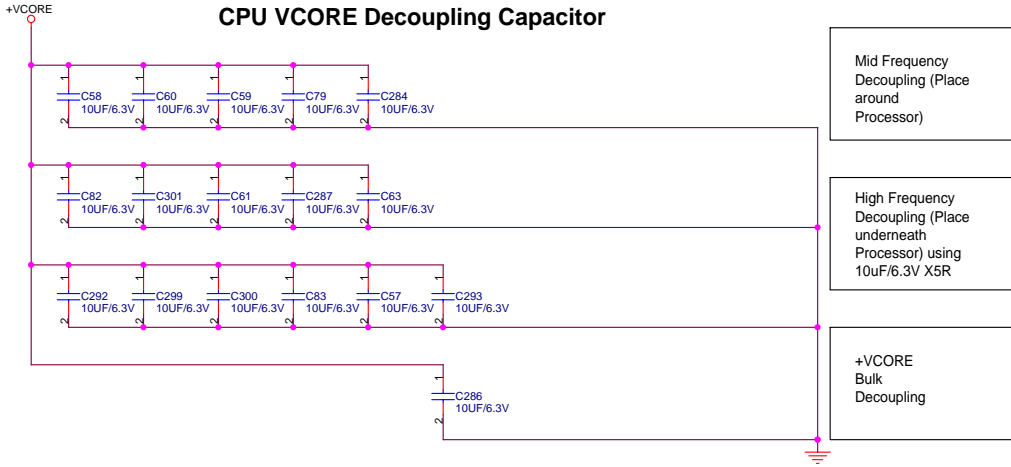

M3N : Four 200 uF are located in IMVP4
 A3N : Delete 10uF/6.3V from 35pcs to 17pcs

+VCCP (CPU) Decoupling Capacitor (Place near CPU)

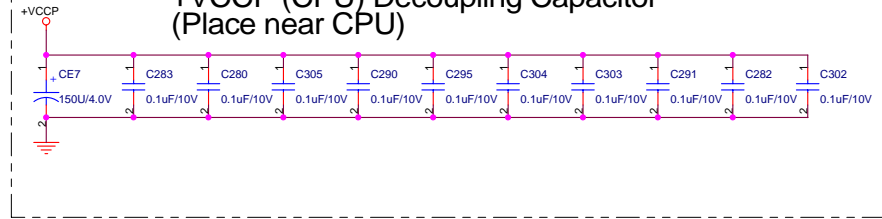

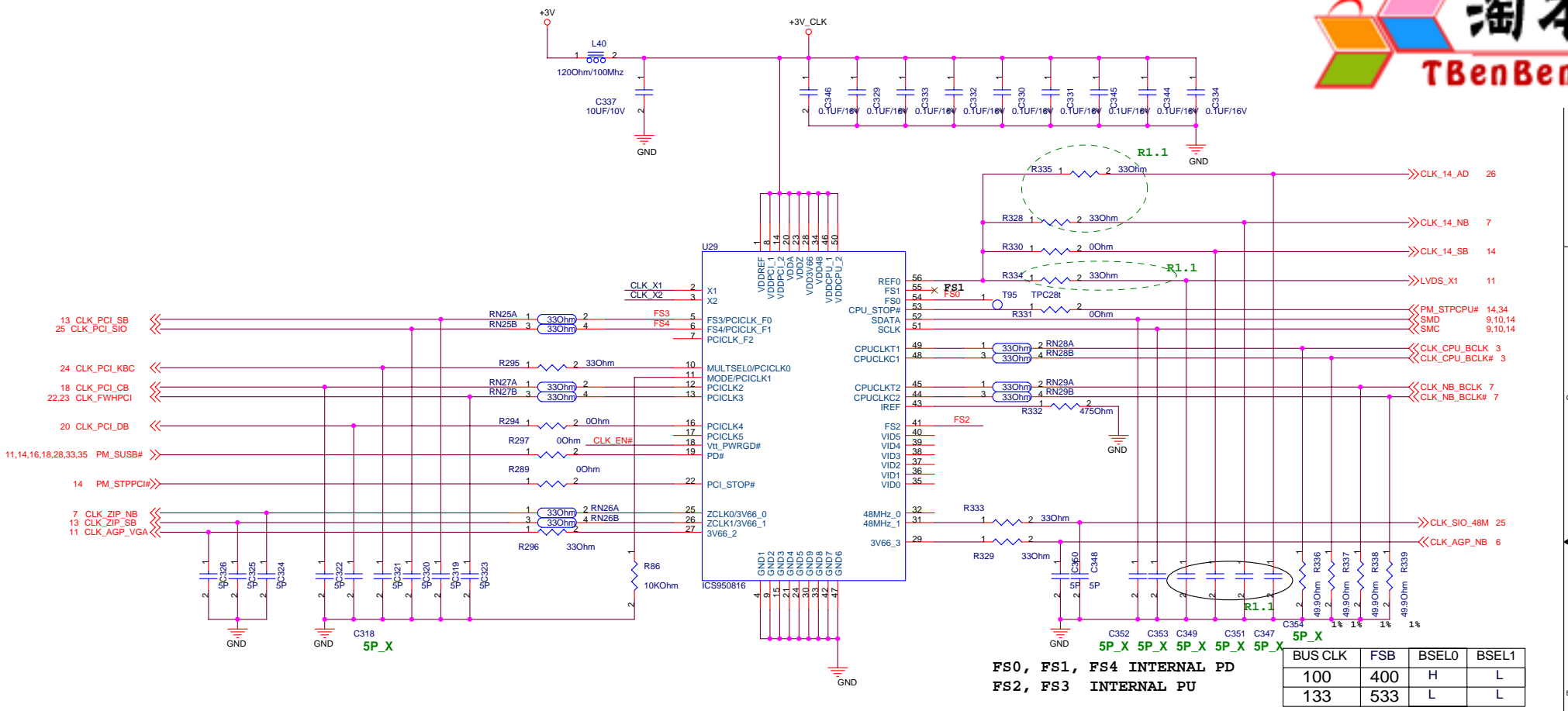

FS0, FS1, FS4 INTERNAL PD
FS2, FS3 INTERNAL PU

BUS CLK	FSB	BSEL0	BSEL1
100	400	H	L
133	533	L	L

FS4	FS3	FS2	FS1	FS0	CPU CLK	AGP CLK	PCI CLK
L	L	H	L	L	100	66.67	33.33
L	H	L	L	L	133	66.67	33.33

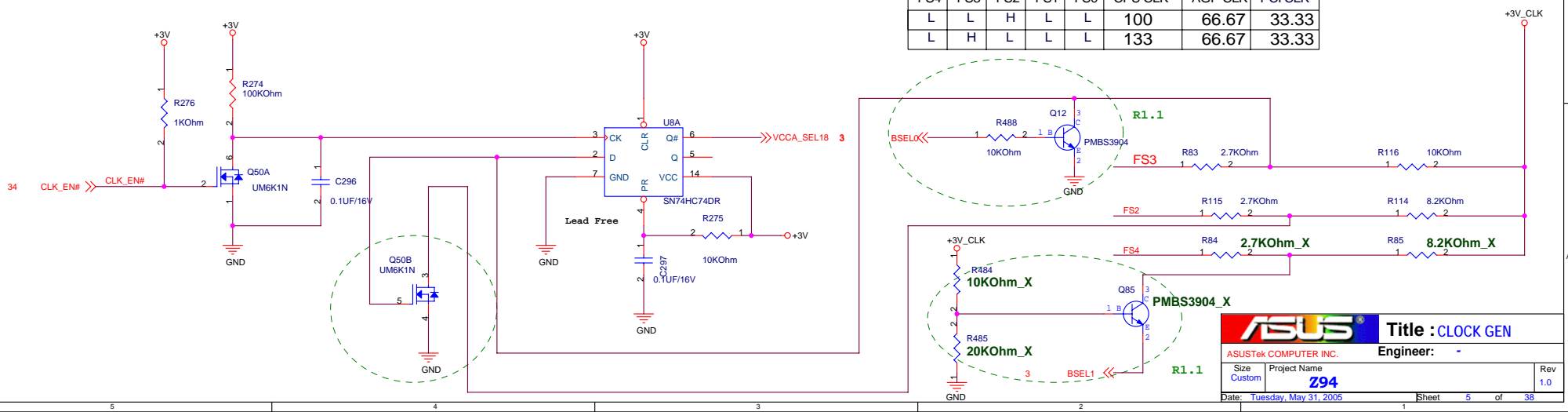

ASUS Title : CLOCK GEN

ASUSTek COMPUTER INC. Engineer: -

Size: Custom Project Name: Z94

Date: Tuesday, May 31, 2005 Sheet 5 of 38



AGP_8XDET#	AGP_BUS	WGA_BUS
LO	HI	

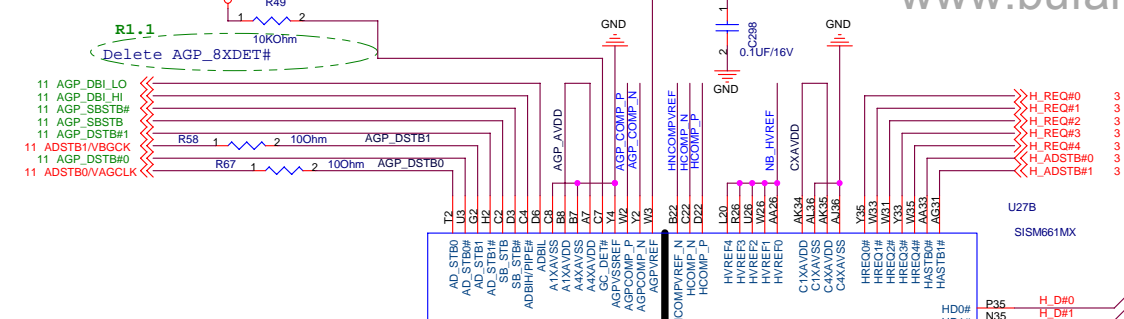

AGP

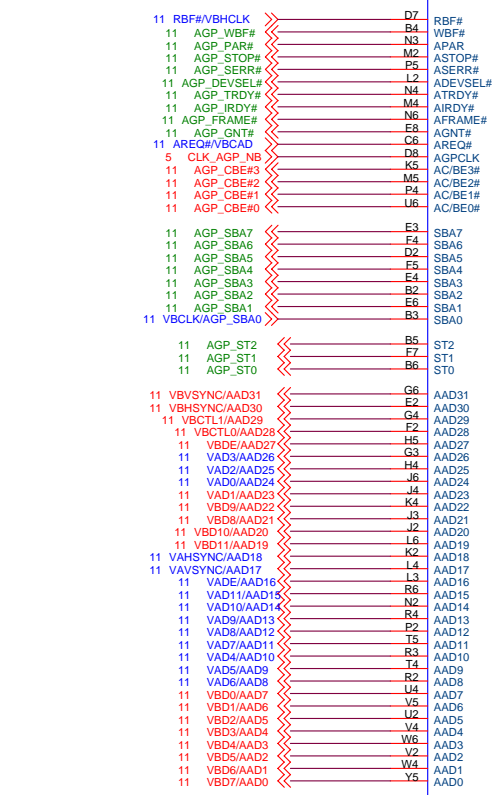

HOST

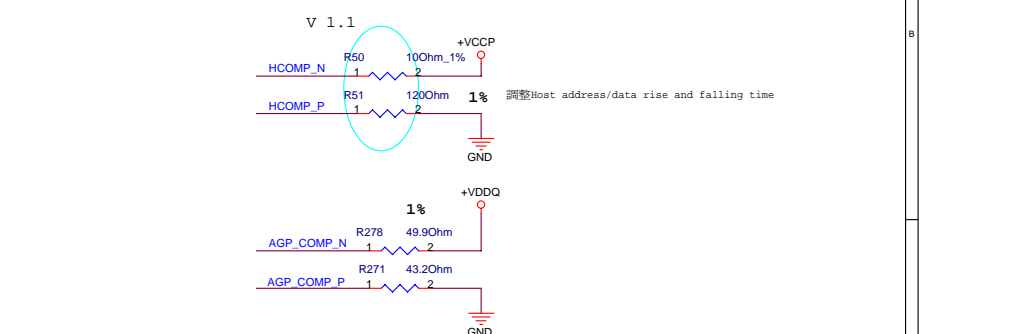
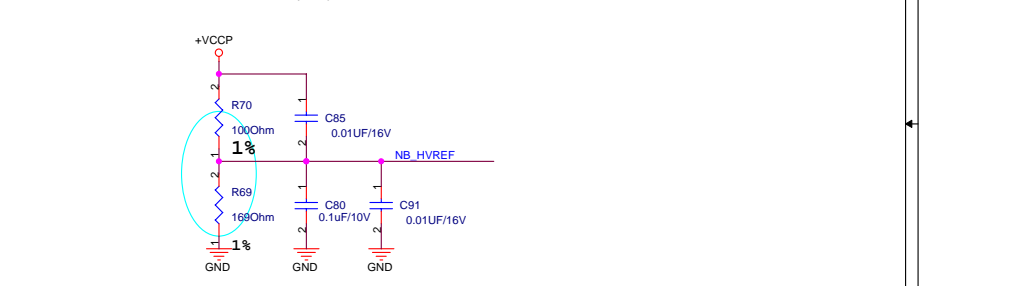
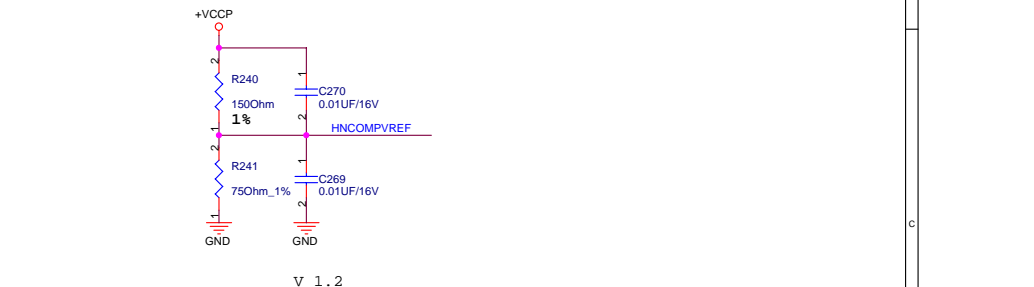
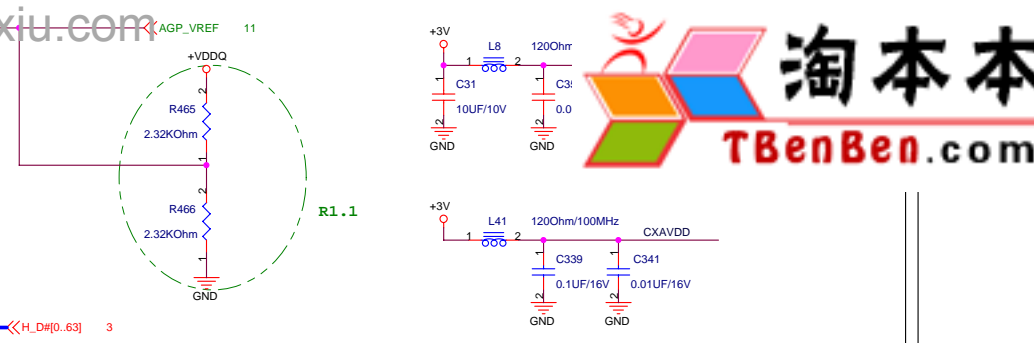
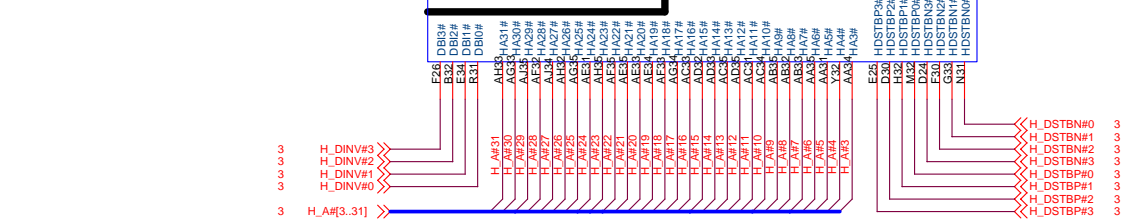

ASUS Title : SISM661MX_HOST/AGP
 ASUSTek COMPUTER INC. Engineer: -
 Size Project Name
 Custom Z94
 Date: Tuesday, May 31, 2005 Sheet 6 of 38

When system power ready will pass to CPU

www.asus.com

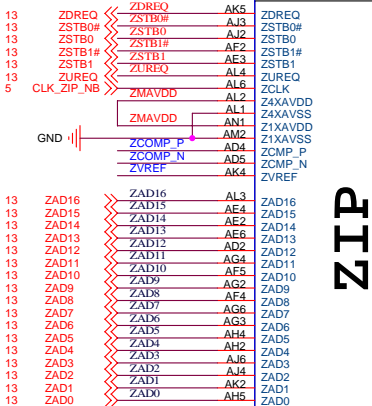
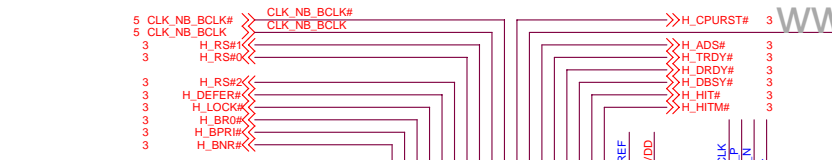

CPU IF

ZIP

DDR

661 VGA

MD63	MD63
MD62	MD62
MD61	MD61
MD60	MD60
MD59	MD59
MD58	MD58
MD57	MD57
MD56	MD56
MD55	MD55
MD54	MD54
MD53	MD53
MD52	MD52
MD51	MD51
MD50	MD50
MD49	MD49
MD48	MD48
MD47	MD47
MD46	MD46
MD45	MD45
MD44	MD44
MD43	MD43
MD42	MD42
MD41	MD41
MD40	MD40
MD39	MD39
MD38	MD38
MD37	MD37
MD36	MD36
MD35	MD35
MD34	MD34
MD33	MD33
MD32	MD32
MD31	MD31
MD30	MD30
MD29	MD29
MD28	MD28
MD27	MD27
MD26	MD26
MD25	MD25
MD24	MD24
MD23	MD23
MD22	MD22
MD21	MD21
MD20	MD20
MD19	MD19
MD18	MD18
MD17	MD17
MD16	MD16
MD15	MD15
MD14	MD14
MD13	MD13
MD12	MD12
MD11	MD11
MD10	MD10
MD9	MD9
MD8	MD8
MD7	MD7
MD6	MD6
MD5	MD5
MD4	MD4
MD3	MD3
MD2	MD2
MD1	MD1
MD0	MD0
MD19	MD19
MD18	MD18
MD17	MD17
MD16	MD16
MD15	MD15
MD14	MD14
MD13	MD13
MD12	MD12
MD11	MD11
MD10	MD10
MD9	MD9
MD8	MD8
MD7	MD7
MD6	MD6
MD5	MD5
MD4	MD4
MD3	MD3
MD2	MD2
MD1	MD1
MD0	MD0

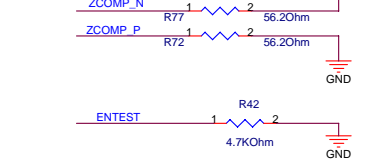
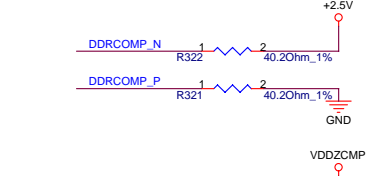
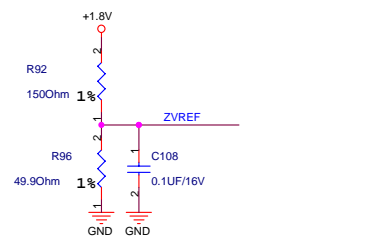
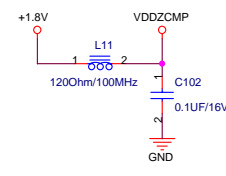
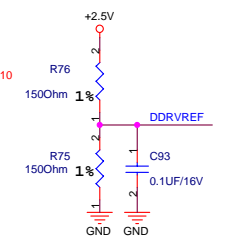
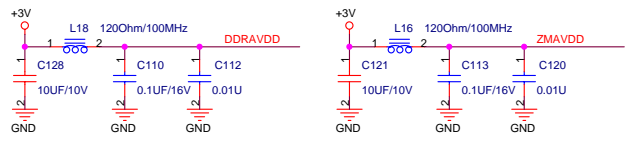
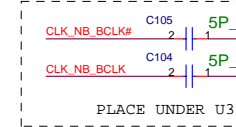
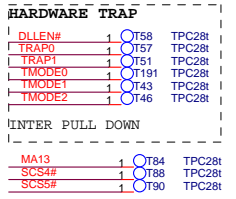
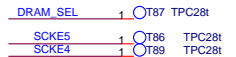
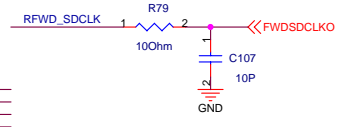
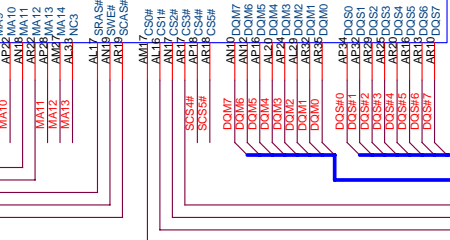
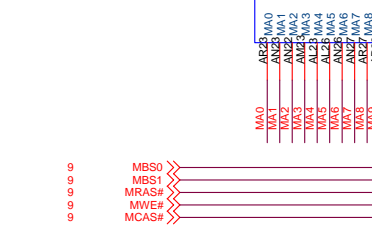
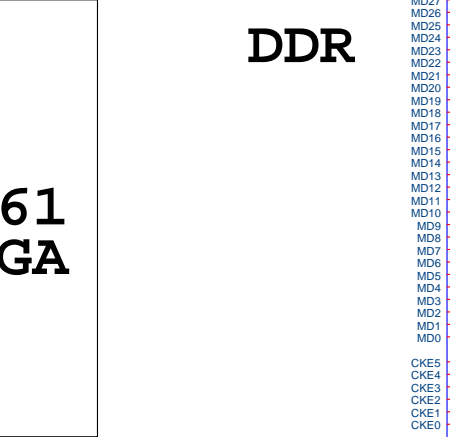
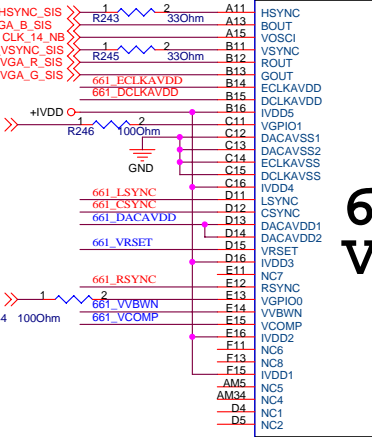

FOR SIS661 ONLY

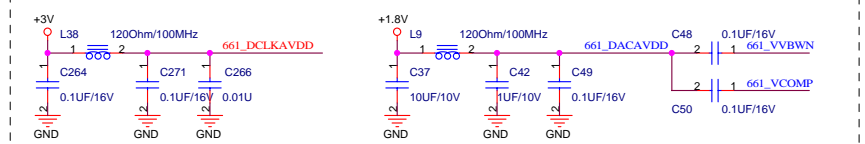

	Function	Enable	Disable
RSYNC	VGA	1	0
LSYNC	TBD	0	0
CSYNC	TBD	0	0

ASUS Title : SISM61MX_DDR/VGA

ASUSTek COMPUTER INC. Engineer: -

Size: Custom Project Name: Z94

Date: Tuesday, May 31, 2005 Sheet 7 of 38

VDD2 = +1.8V = 300 mA
 VDD3.3 = +3V = 200 mA
 VDDQ = +VDDQ = +VDDQ_S = 93.8 mA
 VTT = VCCP1 = 101.1 mA
 VDDM = +2.5V = 442 mA
 AUX_IVDD = +AUX_IVDD = +1.8V_AUX = 10 mA
 IVDD = +1.8V = 1721 mA
 FVDD = +1.8V = 78.7 mA

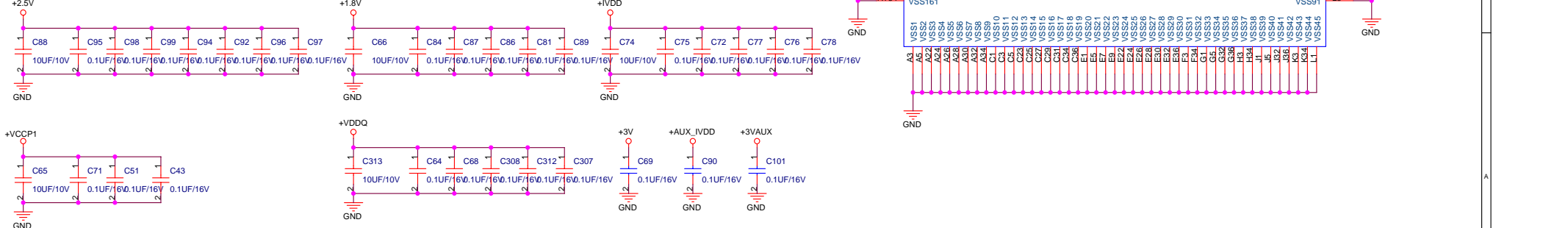
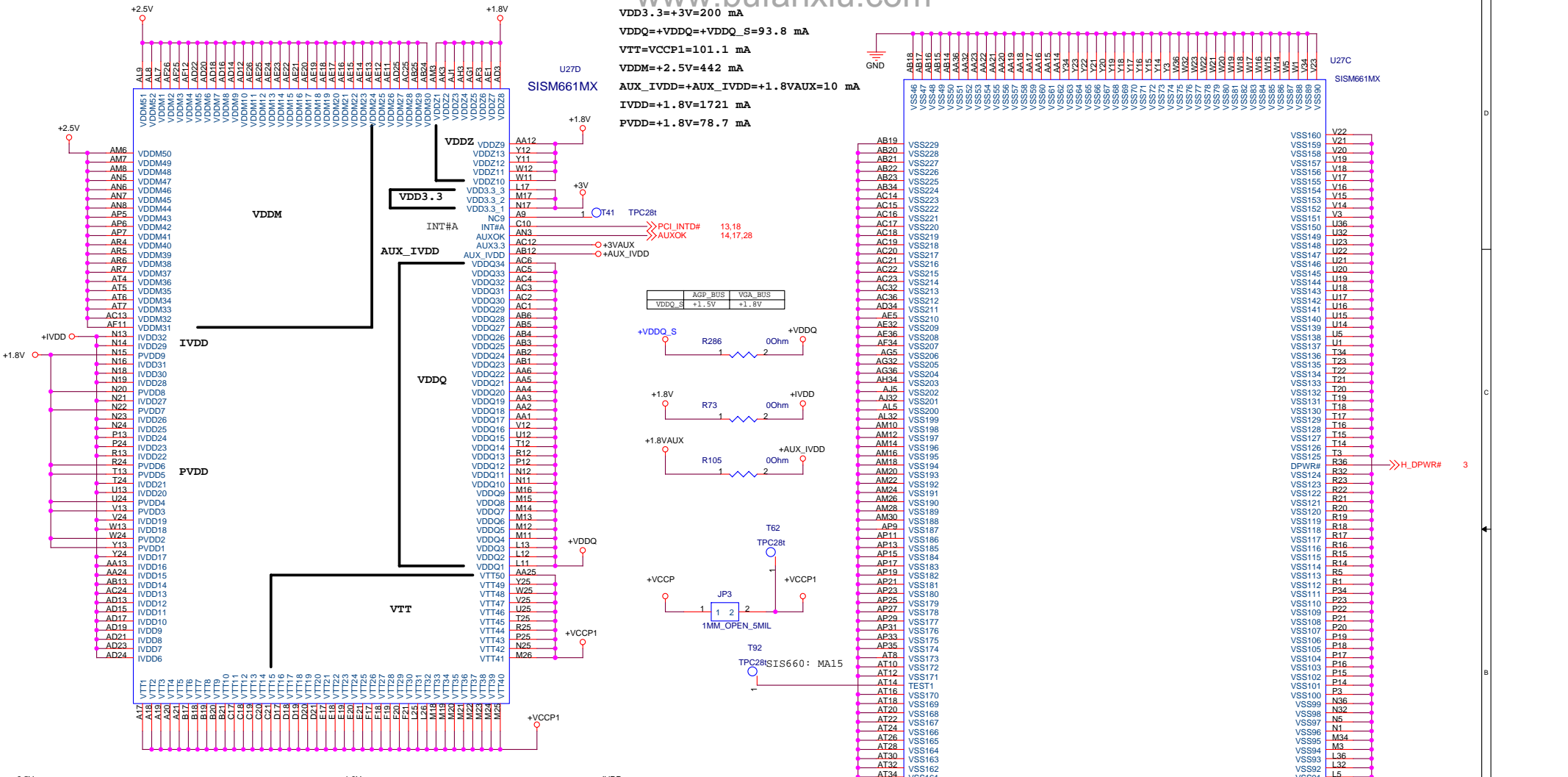

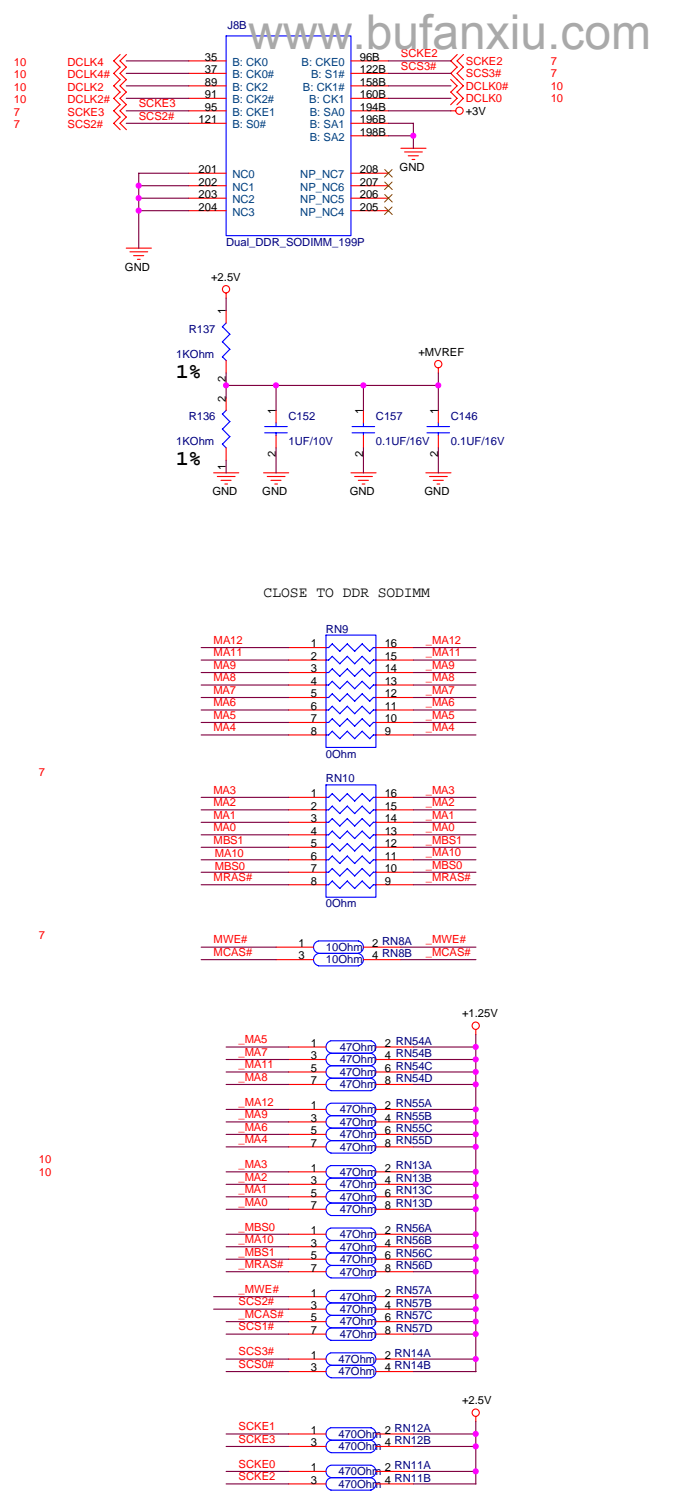
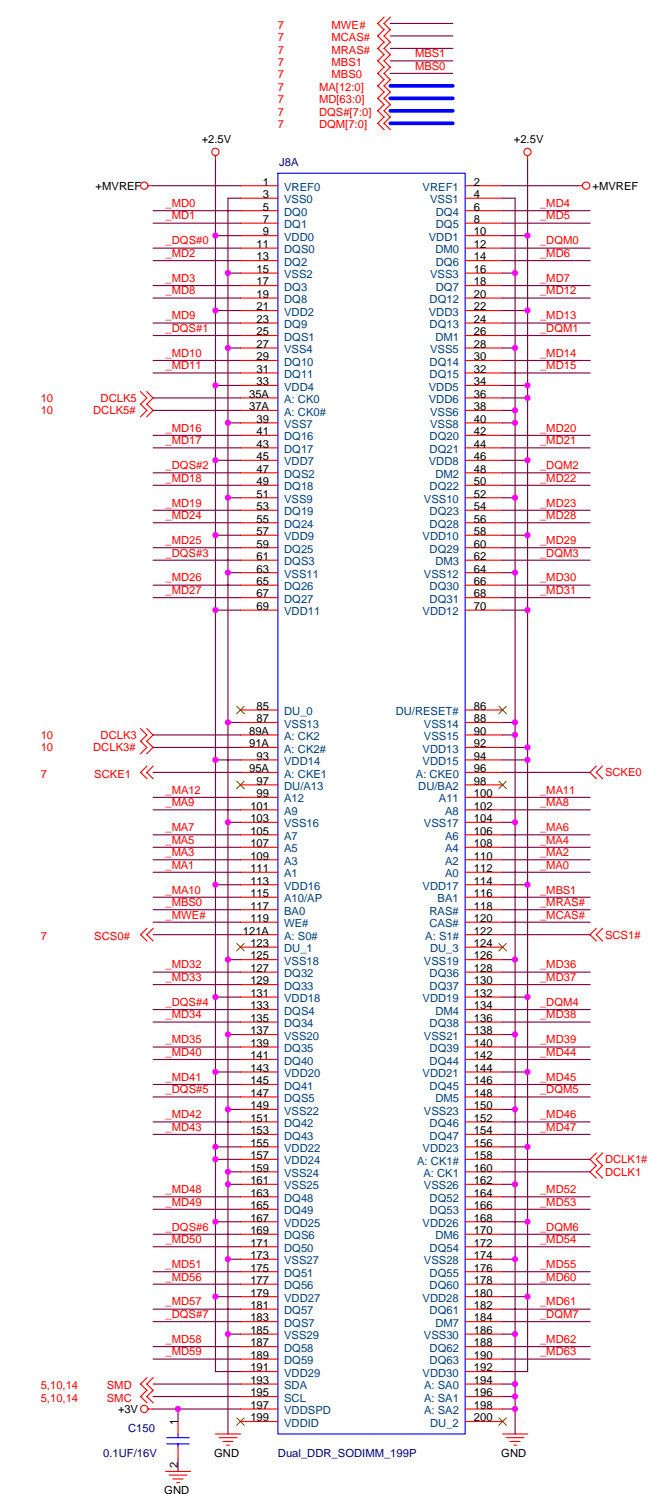

CLOSE TO DDR SODIMM

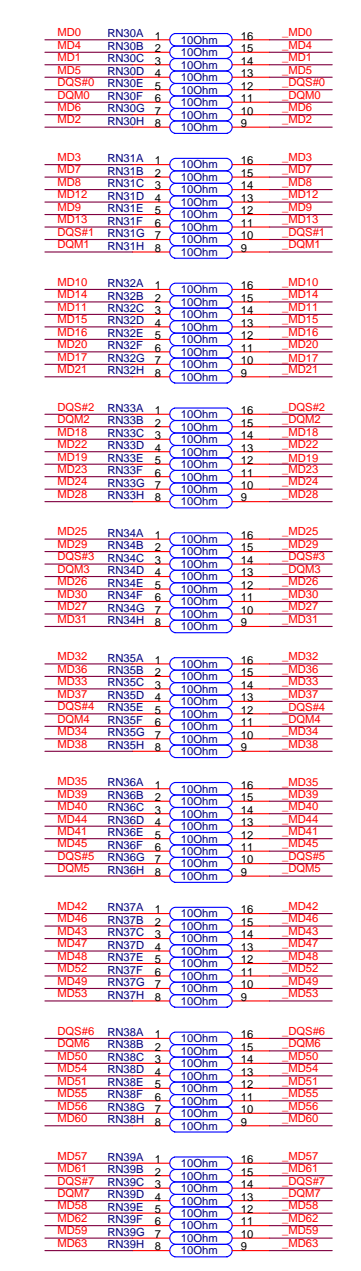

CHANGE TO 47 OHM

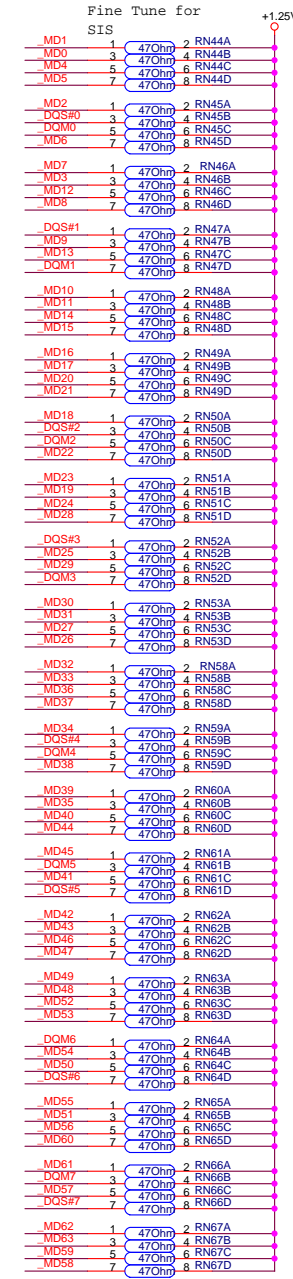

CLOSE TO DDR SODIMM

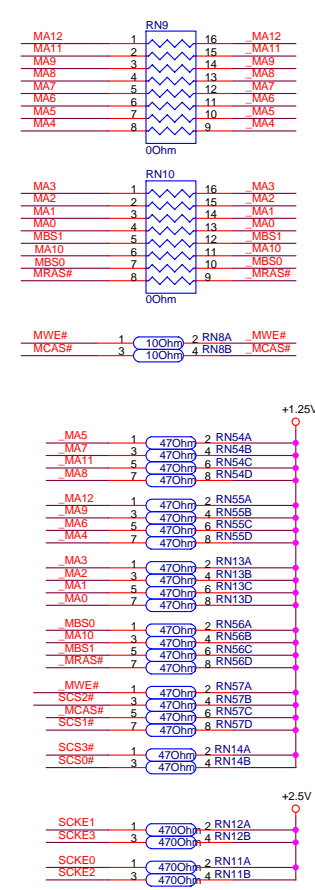

ASUS Title : DDR MEMORY DIMM
 ASUSTek COMPUTER INC. Engineer: -
 Size: Custom Project Name: Z94
 Date: Tuesday, May 31, 2005 Sheet 9 of 38 Rev 2.0

Close to DDR socket

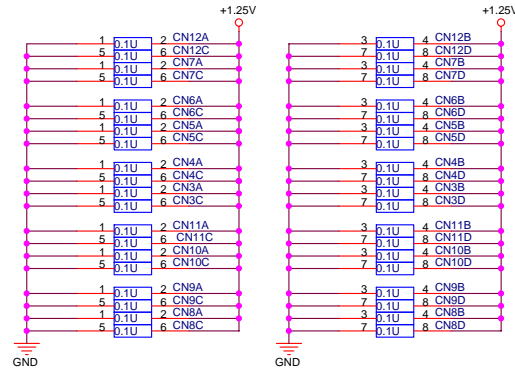
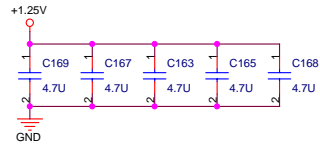
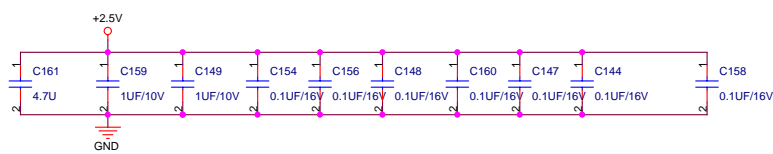

0.1U OP X 4

DDR BUFFER

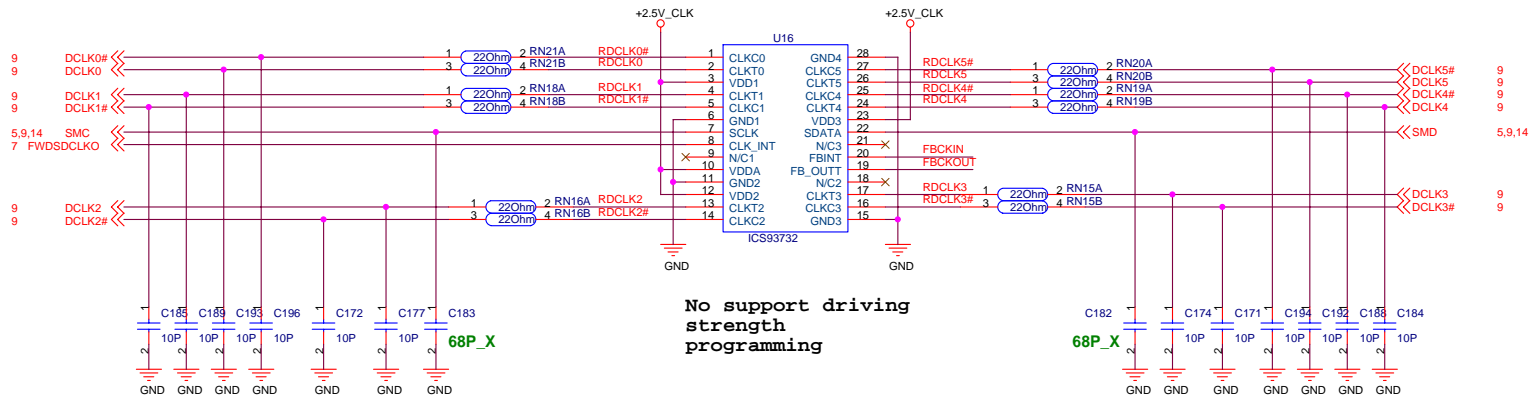
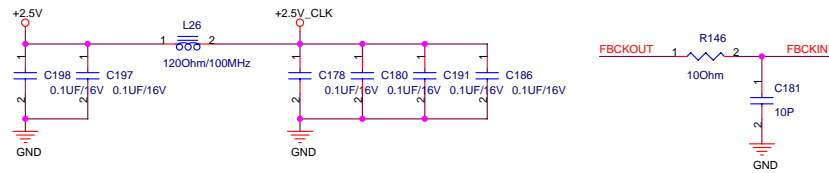

No support driving strength programming

68P_X

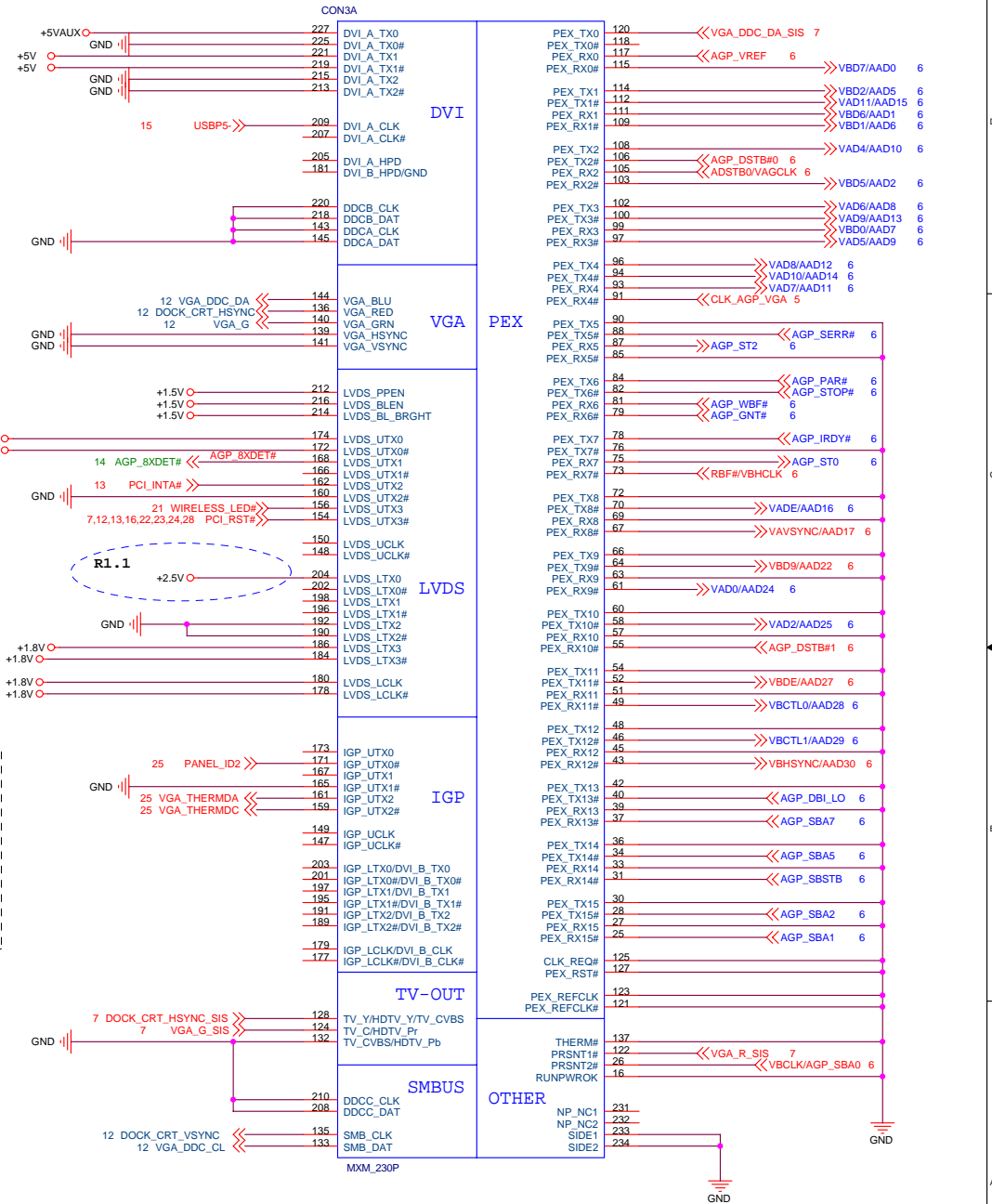
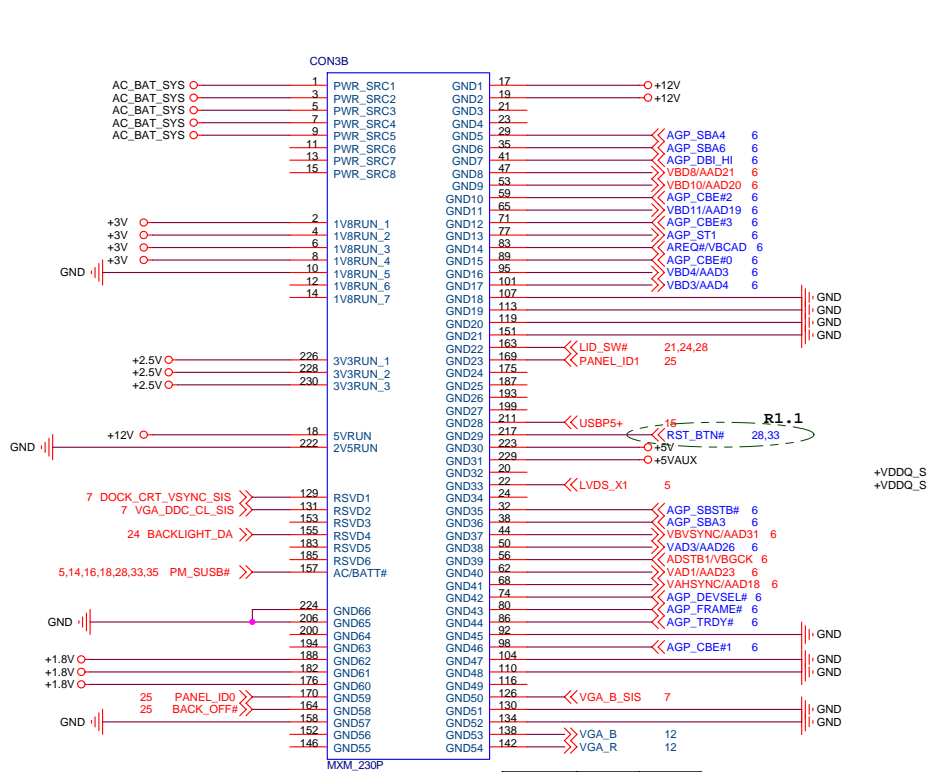

AGP_BUS	VGA_BUS
LO	HI

- AC_BAT_SYS ---> 2 A
- +12V = 0.5A
- +5V = 1.5A
- +3V = 1.5A
- +2.5V = 2.0A
- +1.8V = 2.0A
- +5VAUX = 1.0A
- +1.5V ---> 0.5A

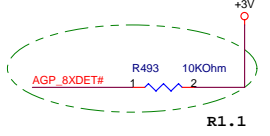
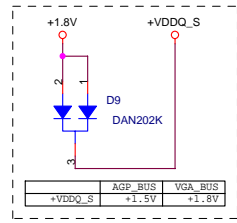

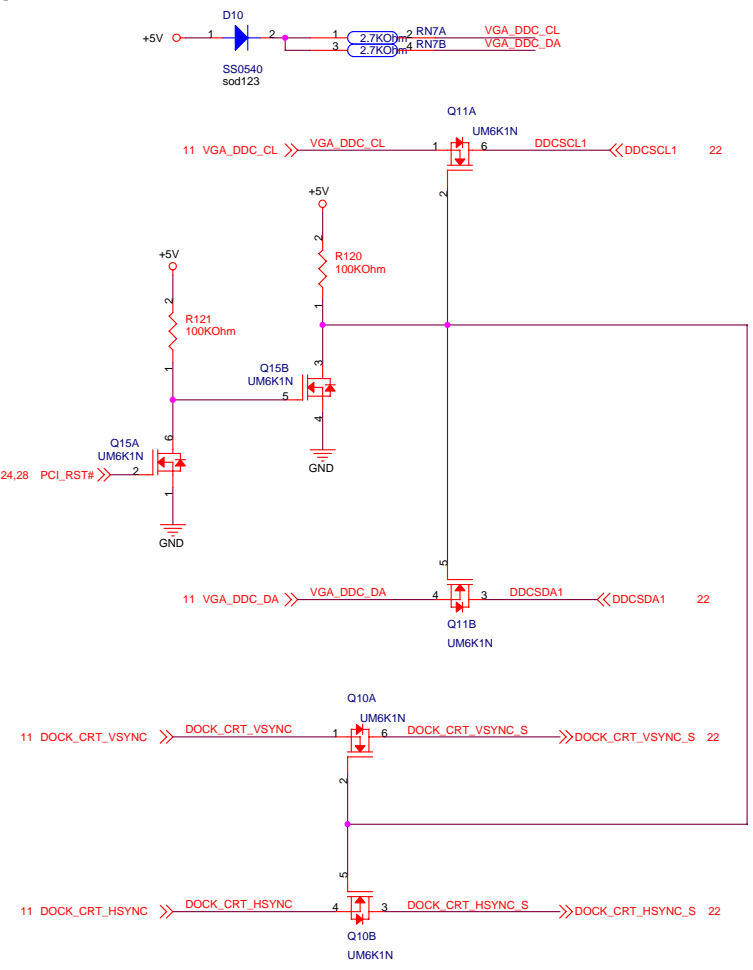
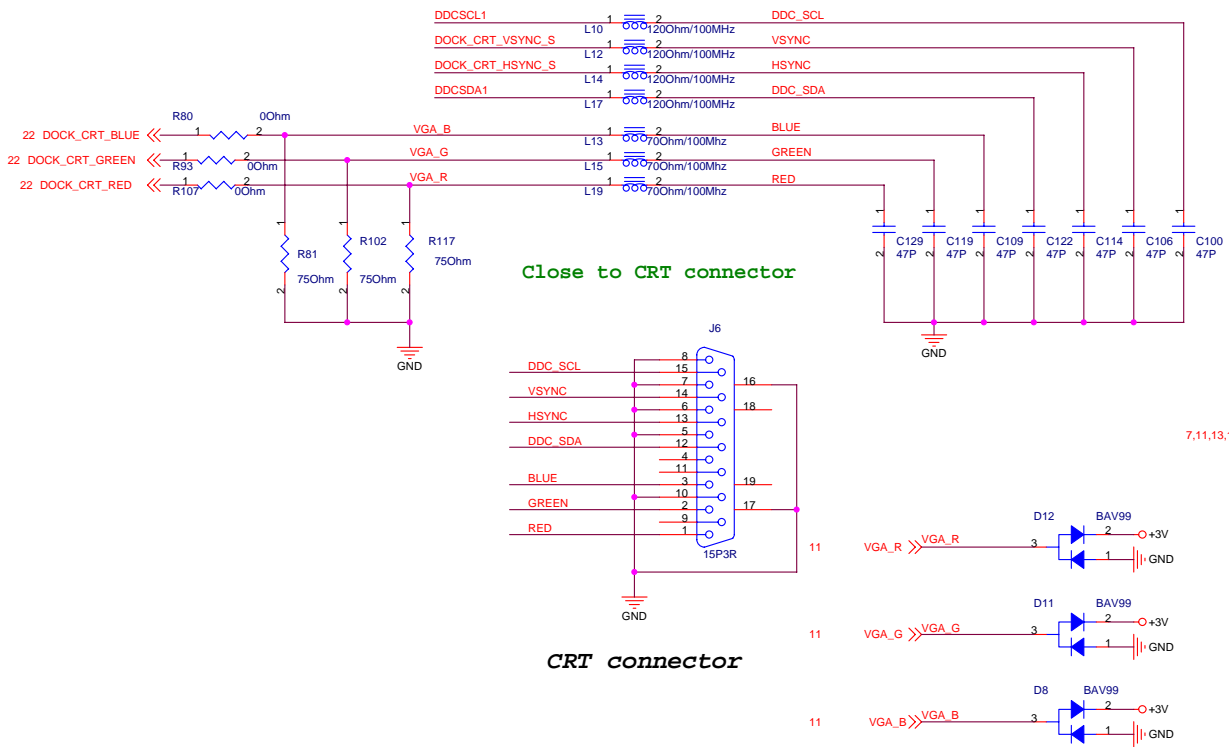

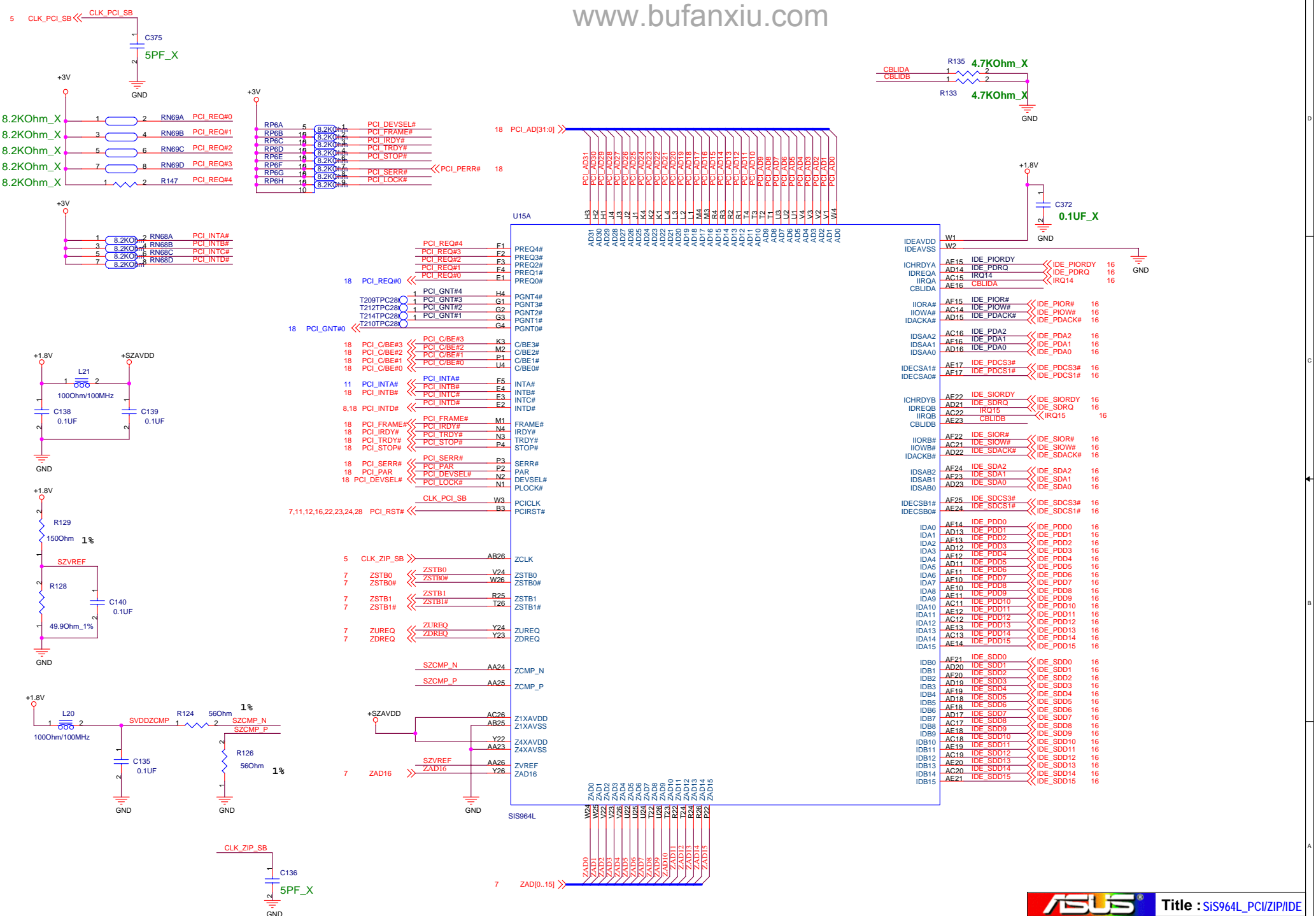

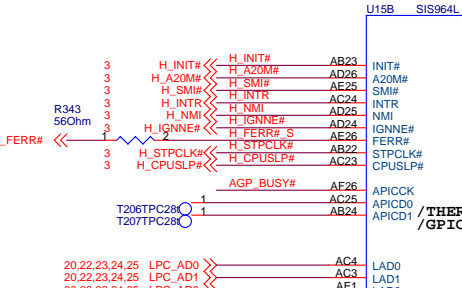
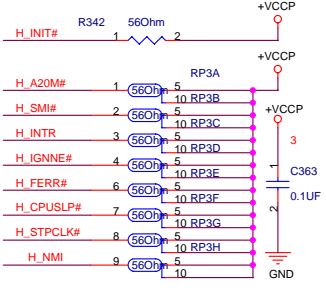

CPU_S

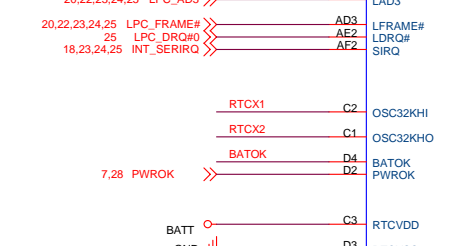
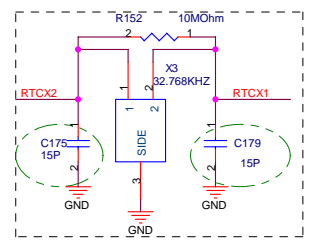

LPC

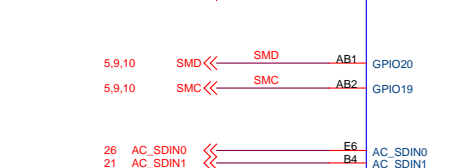
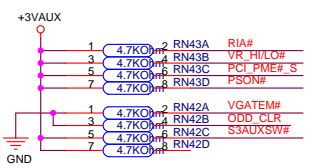

AC97

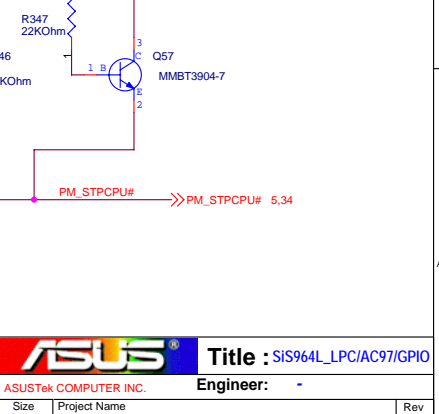
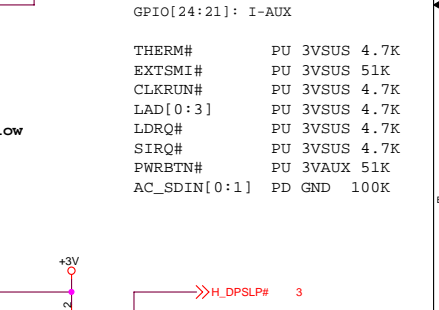
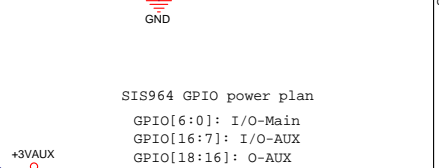
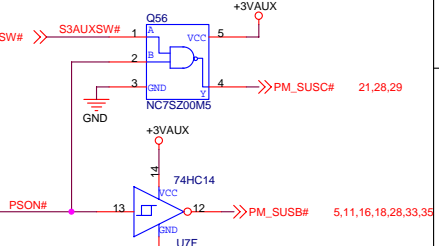
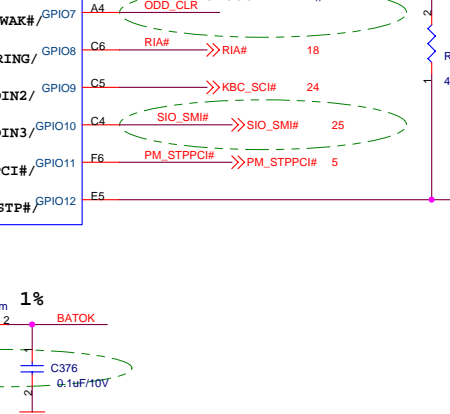
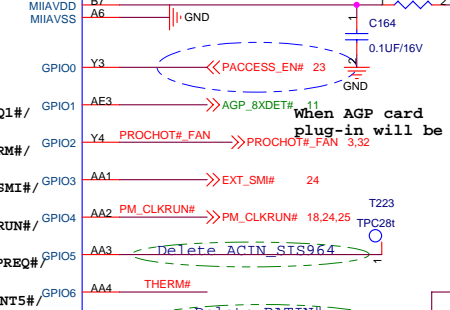
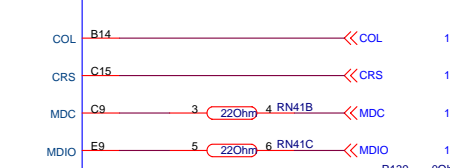
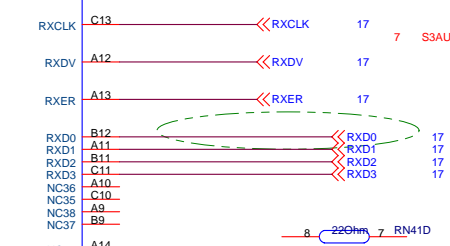
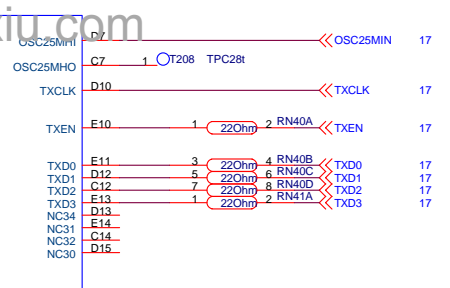
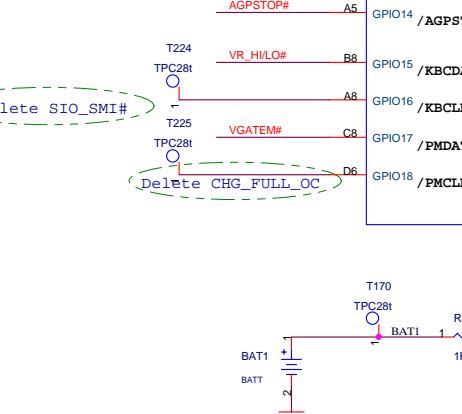
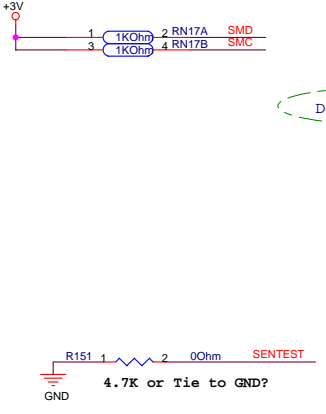
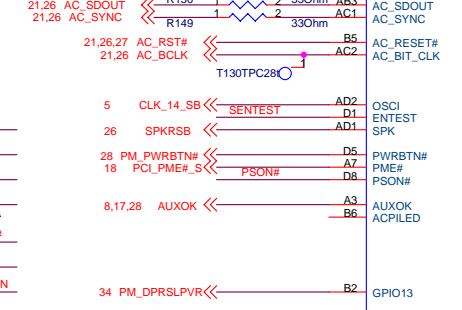
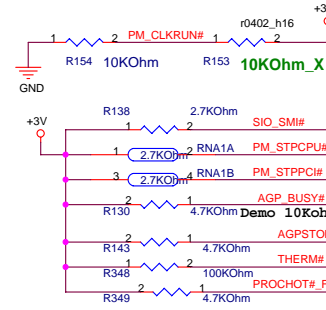

SIS964 GPIO power plan
GPIO[6:0]: I/O-Main
GPIO[16:7]: I/O-AUX
GPIO[18:16]: O-AUX
GPIO[20:19]: OD-AUX
GPIO[24:21]: I-AUX

THERM# PU 3VSUS 4.7K
EXTSMI# PU 3VSUS 51K
CLKRUN# PU 3VSUS 4.7K
LAD[0:3] PU 3VSUS 4.7K
LDRQ# PU 3VSUS 4.7K
SIRQ# PU 3VSUS 4.7K
PWRBTN# PU 3VAUX 51K
AC_SDIN[0:1] PD GND 100K

when AGP card plug-in will be low

Delete ACTN_SIS964

Delete BATIN#

Delete SIO_SMI#

Delete CHG_FULL_OC

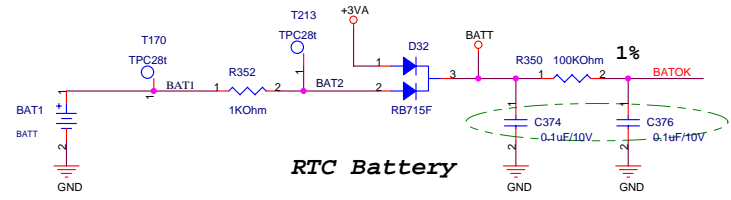

RTC Battery

USB frequency

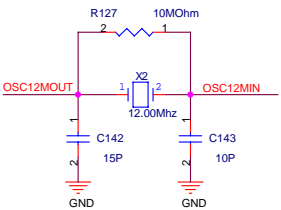

UVDD33=+3VAUX=1mA
UVDD18=UVDD18=+1.8VAUX=274.1mA
USBPVDD18=USBPVDD18=+1.8VAUX=7.9 mA
USBCMPVDD=+USBCMPVDD=+3VAUX=8.5 mA
IVDD_AUX=+1.8VAUX=31.1mA

VDDZ=+1.8V=20 mA
IVDD=+1.8V=517.4 mA
PVDD=+3V=55 mA
OVDD=+3V=55 mA
VTT=+VCCP=28.7 mA
IVDD_AUX=+1.8VAUX=31.1 mA
OVDD_AUX=+3VAUX=52 mA

SIS964L

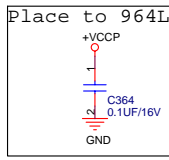
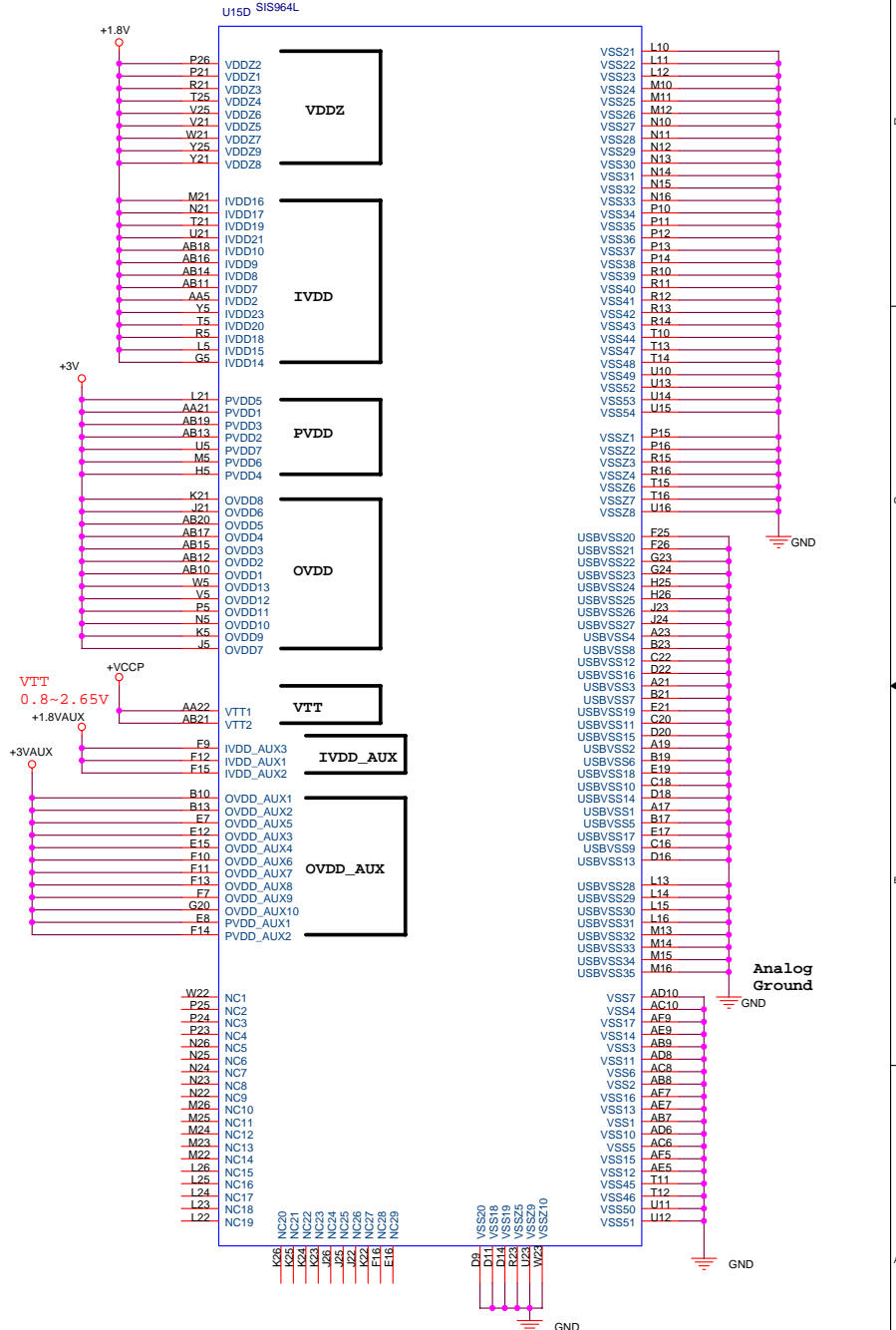
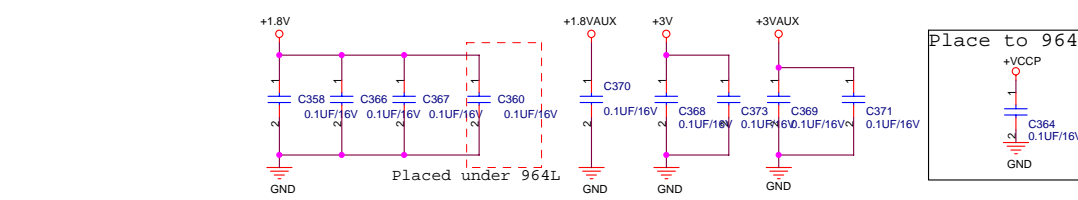
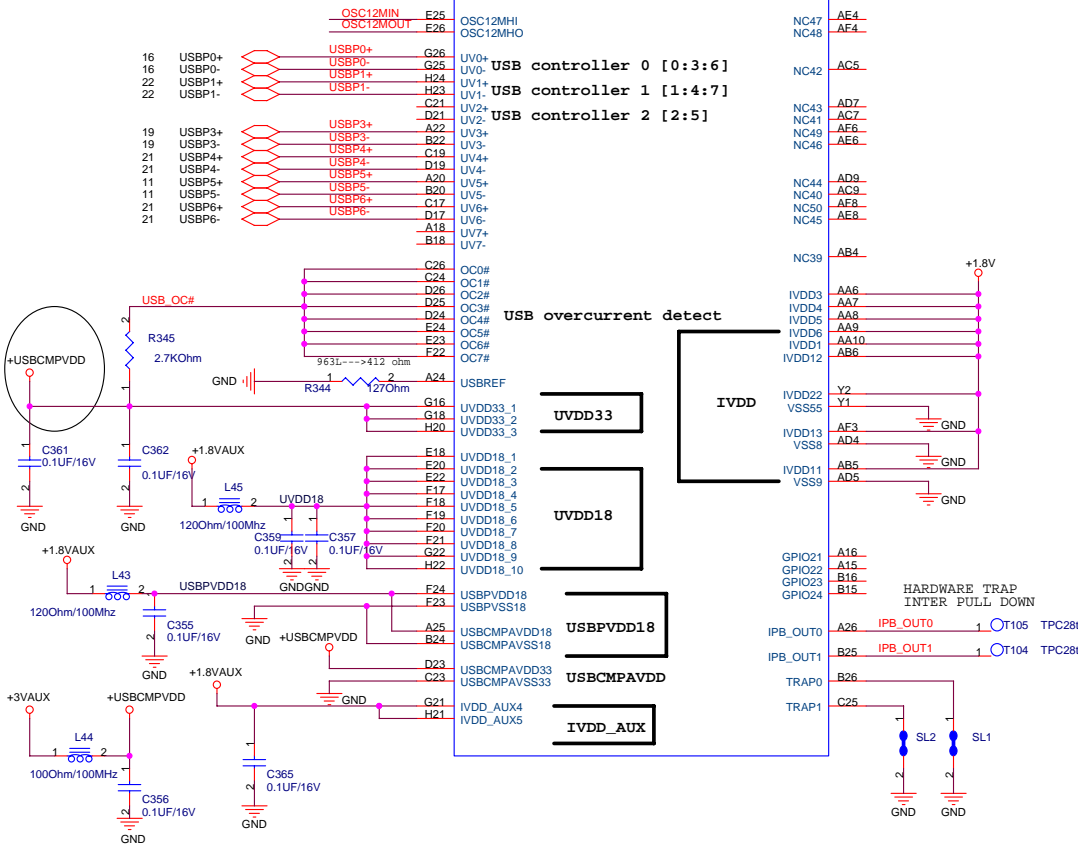

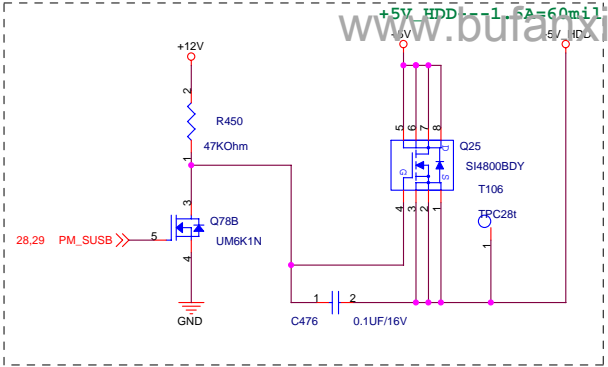
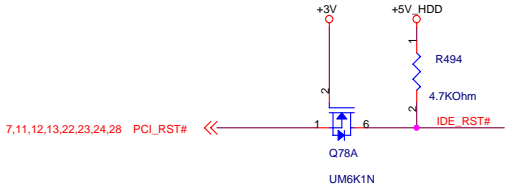

7,11,12,13,22,23,24,28 PCI_RST# <<<
 13 IDE_PDD[15:0] <<<
 13 IDE_SDD[15:0] <<<

2029

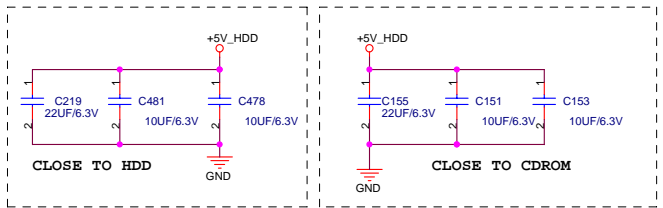
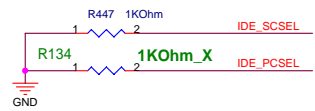
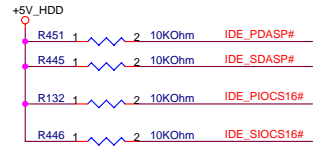
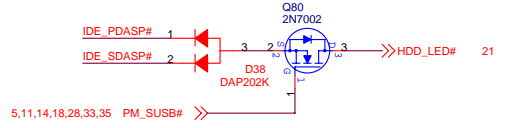
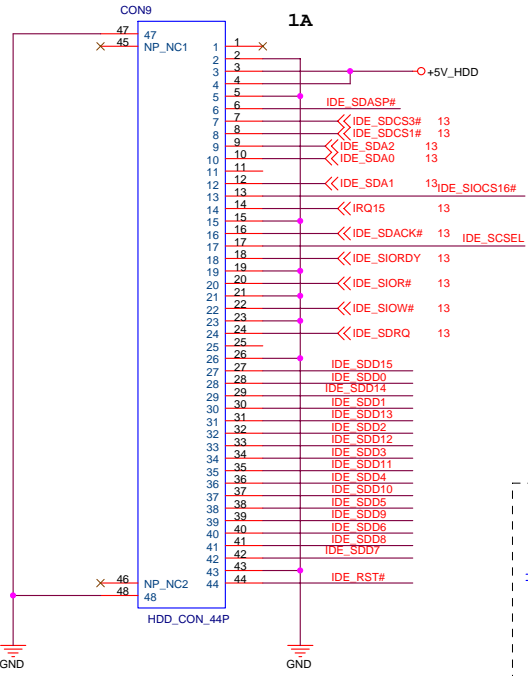
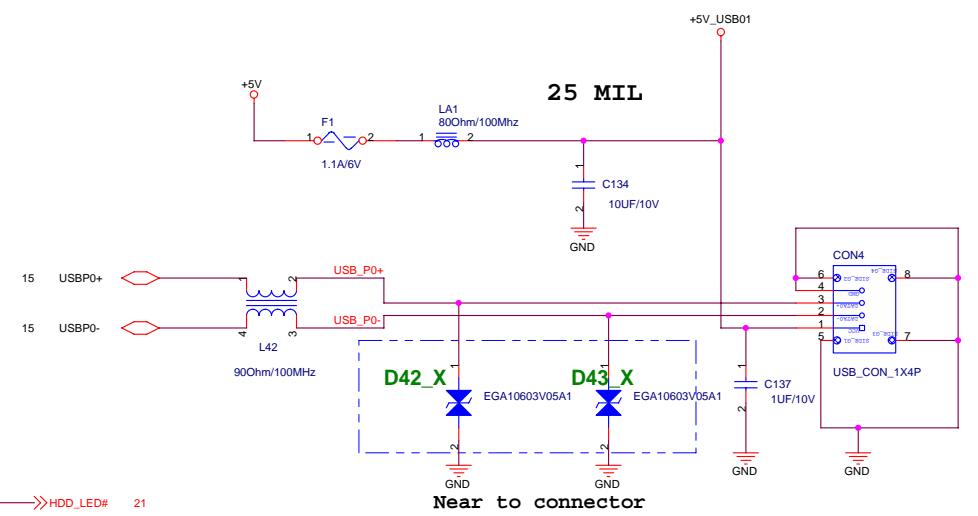
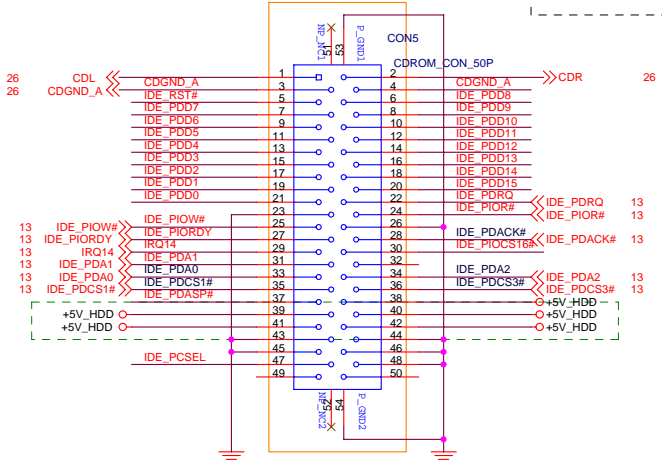

PHY Addr = 00001

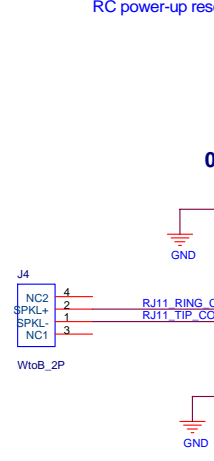
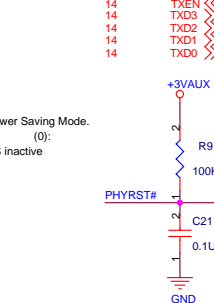
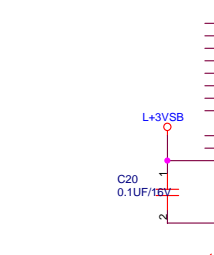
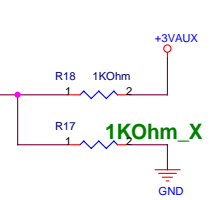
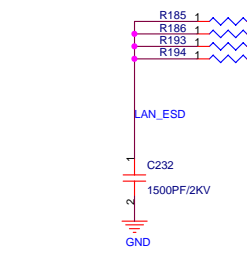
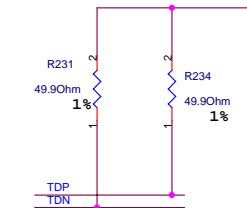
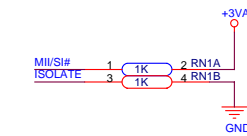
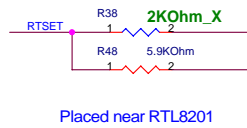
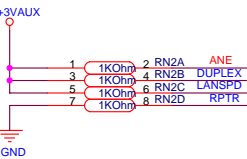
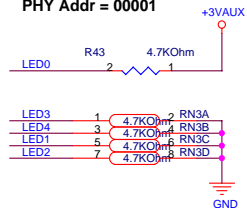

www.buifanxi.com

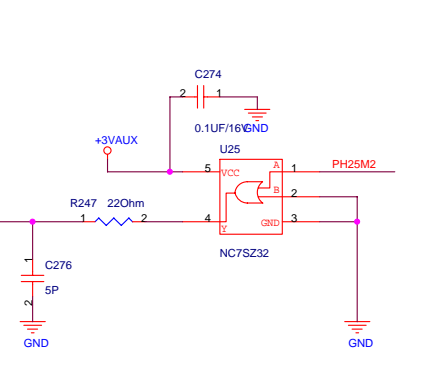
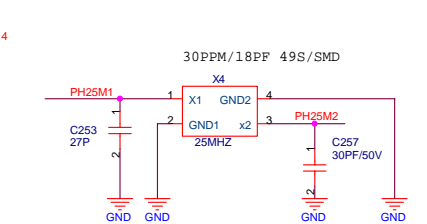
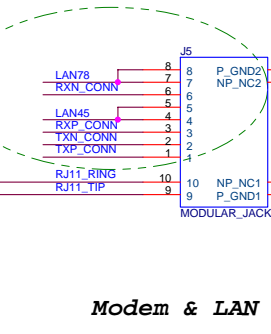
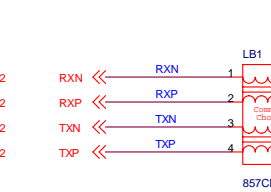
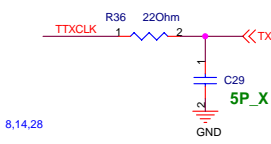
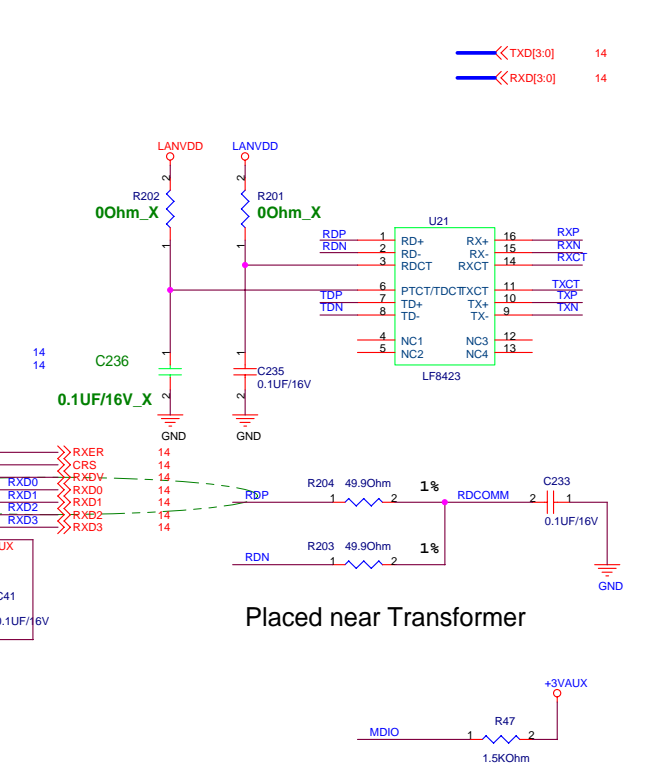
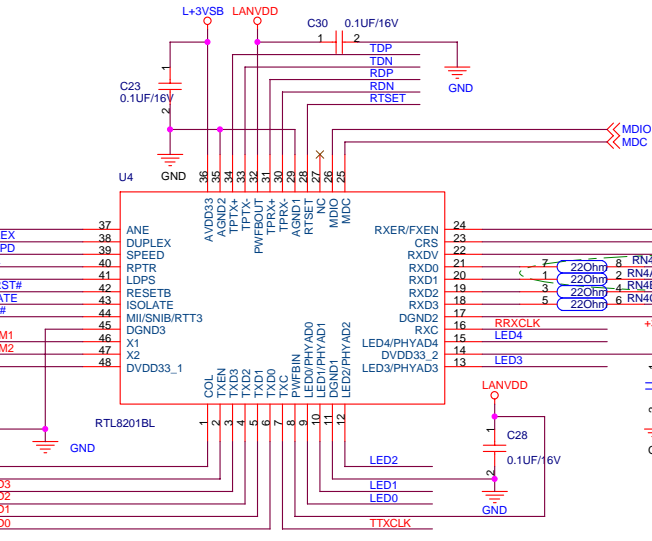

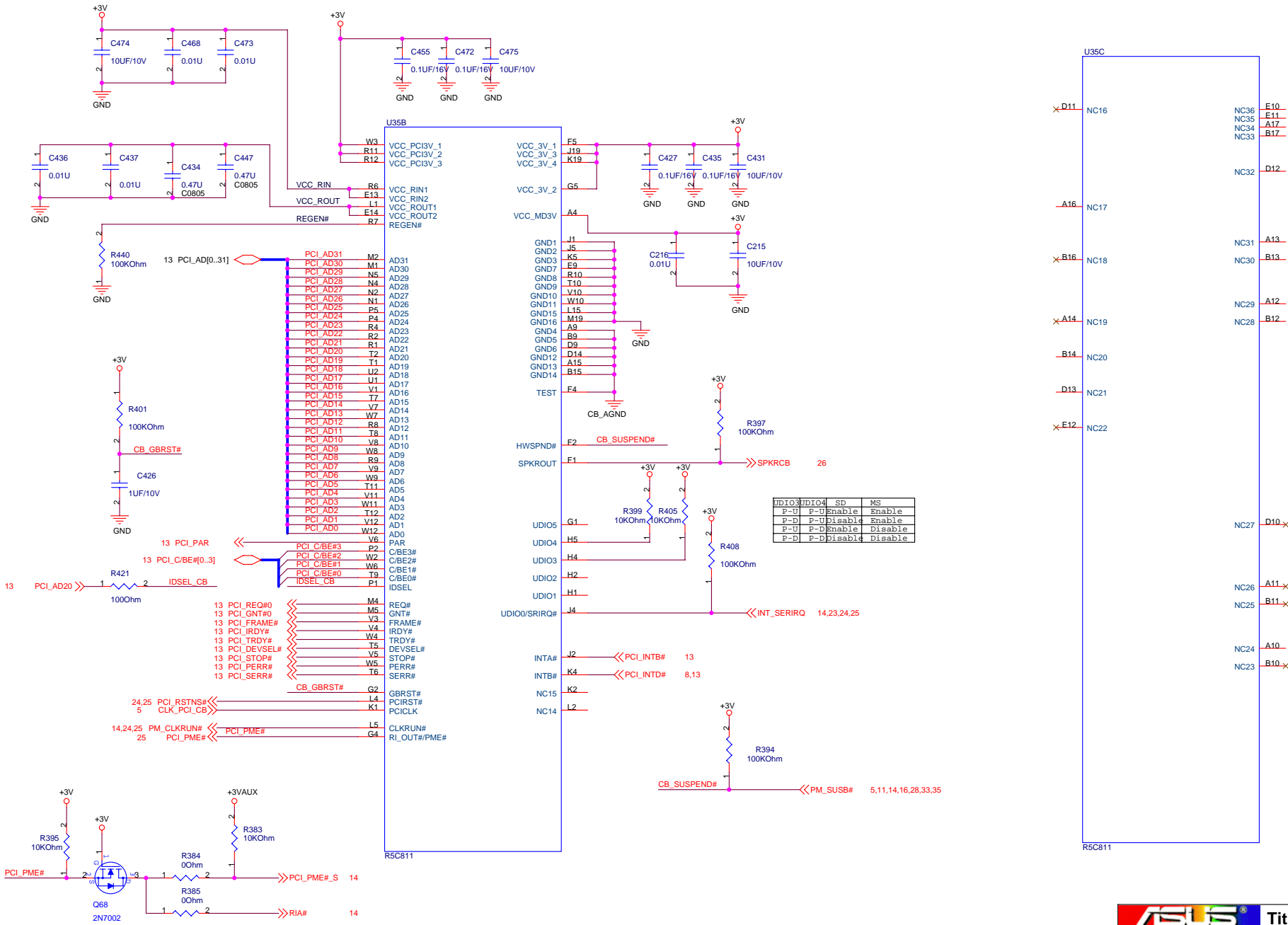

PCMCIA DEBUG

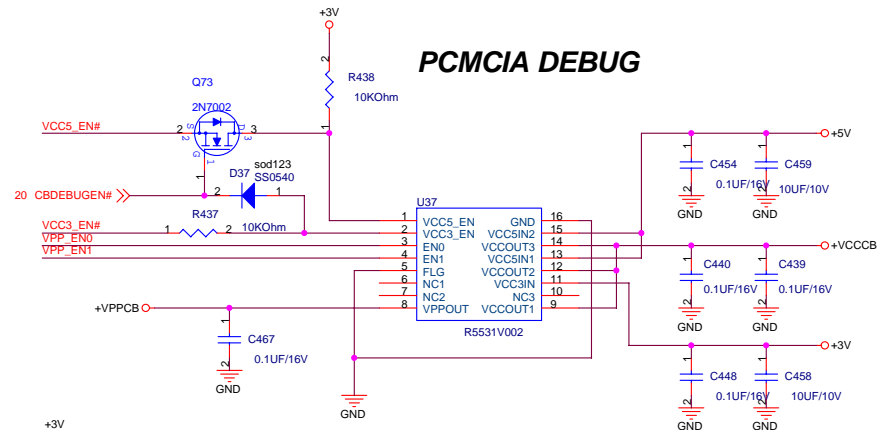

RN70A	1	8.2KOhm	SD_CD#
RN70B	3	8.2KOhm	MS_CD#
RN70C	5	8.2KOhm	MS_WP#
RN70D	7	8.2KOhm	SD_WP#

- MDIO02--> xDCE#
- MDIO05--> SD Power Control 1 / xDWP
- MDIO06--> xD/MS/SD LED Control
- MDIO14--> xD Data
- MDIO15--> xD Data
- MDIO16--> xD Data
- MDIO17--> xD Data
- MDIO18--> xD CLE
- MDIO19--> xD ALE

Memory Card Detect

MS_CD#	SD_CD#	Not_Support
0	0	Not_Support
1	0	Small Card
1	1	Memory Stick

MC_CD# : Memory Card Detect

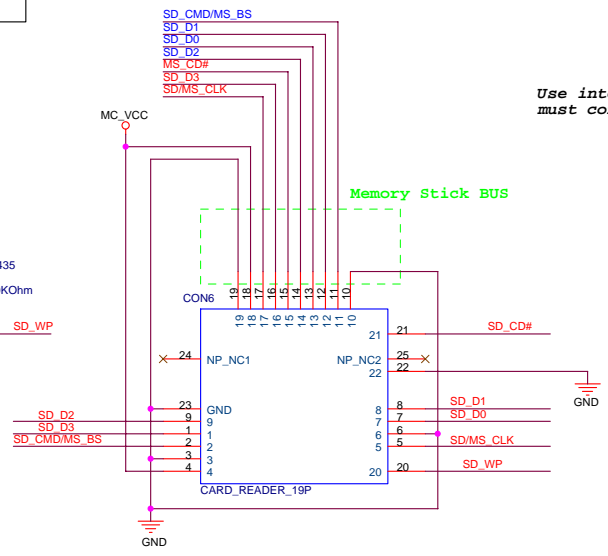

Use internal PCI clock MDIO07 must connect to GND

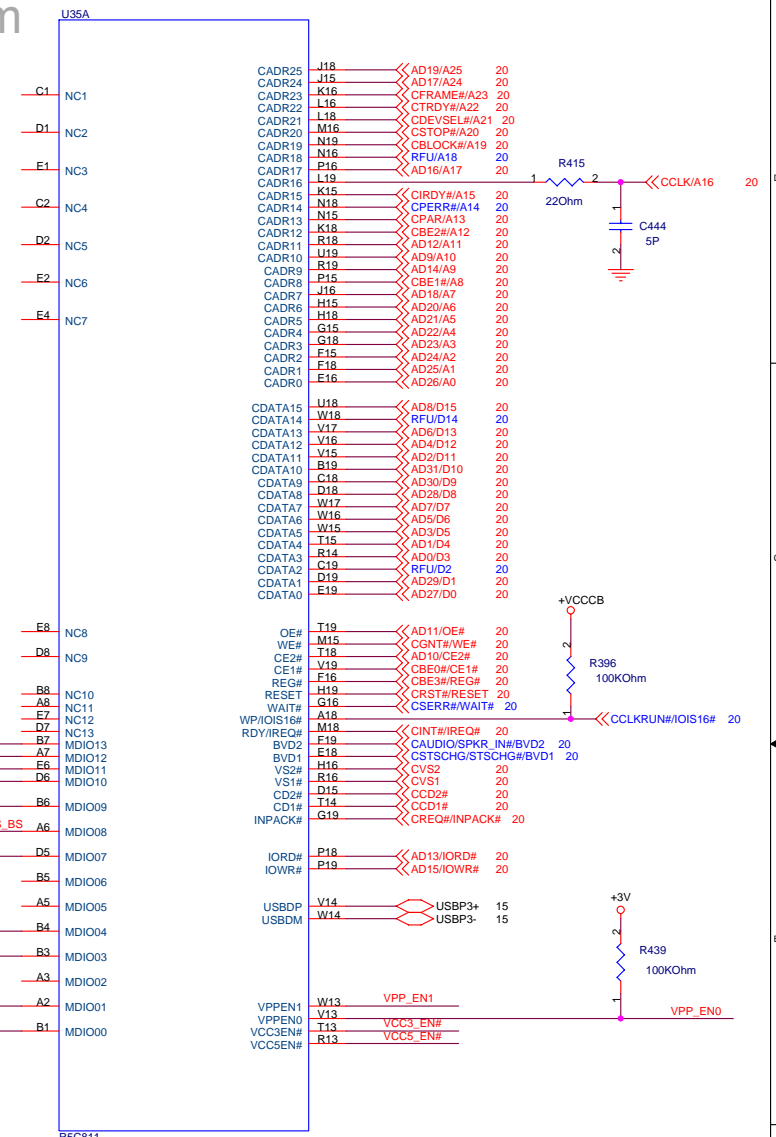
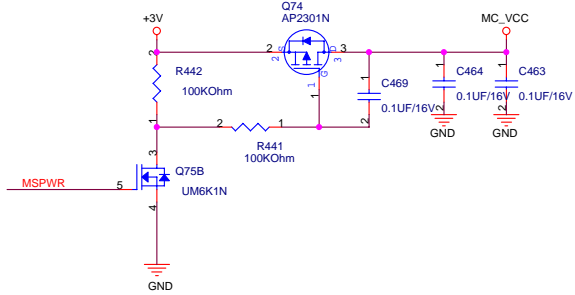

PCMCIA SOCKET

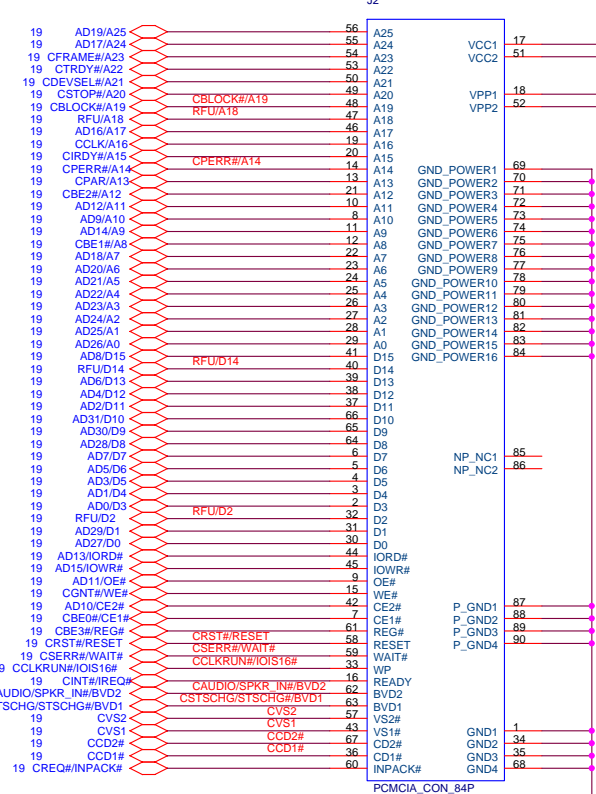

5 CLK_PCL_DB
14,22,23,24,25 LPC_FRAME#
14,22,23,24,25 LPC_AD0
14,22,23,24,25 LPC_AD1
14,22,23,24,25 LPC_AD2
14,22,23,24,25 LPC_AD3
22 DEBUG_EN

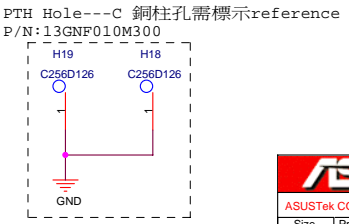
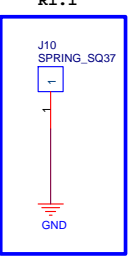
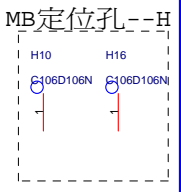
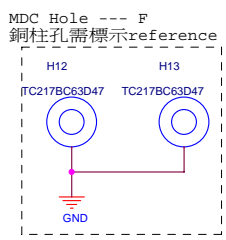
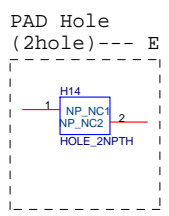
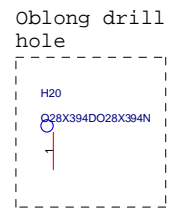
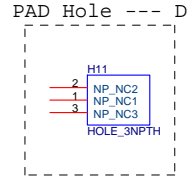
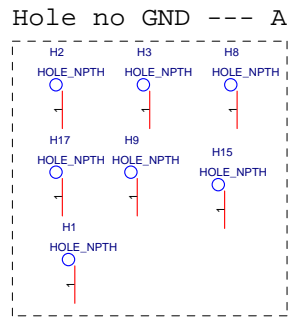
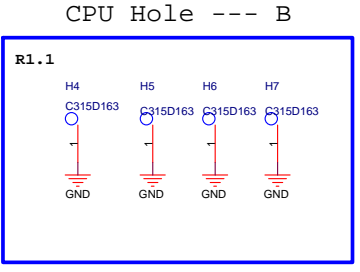
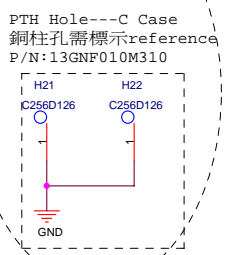
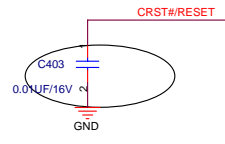
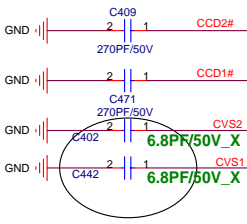
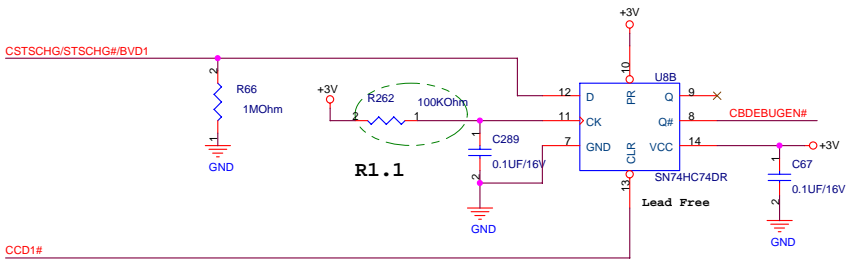
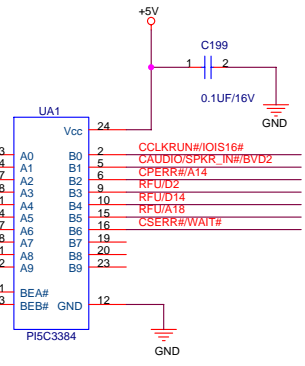

SPKL+,SPKL-,SPKR+,SPKR- trace 15mil width

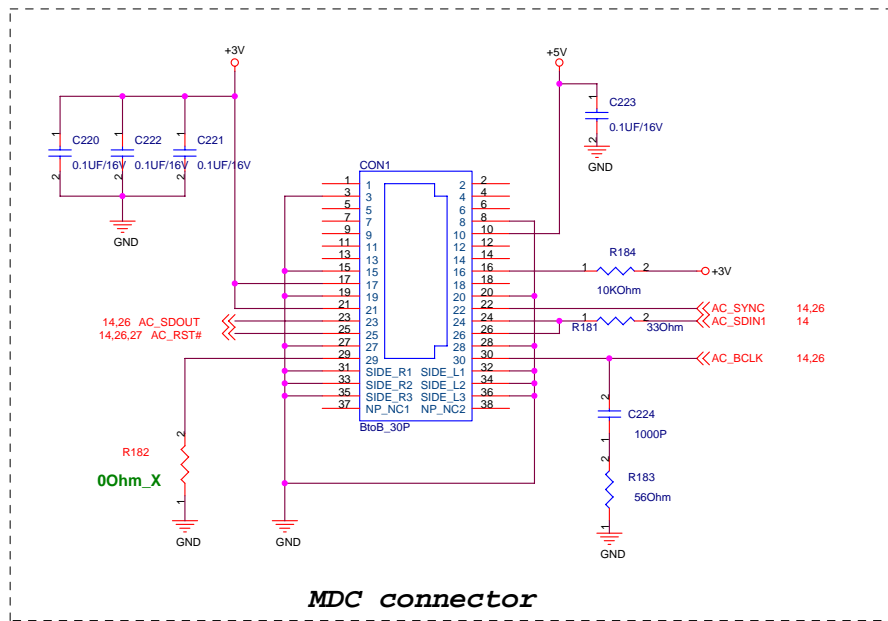
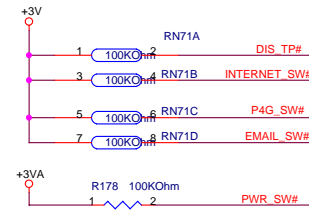
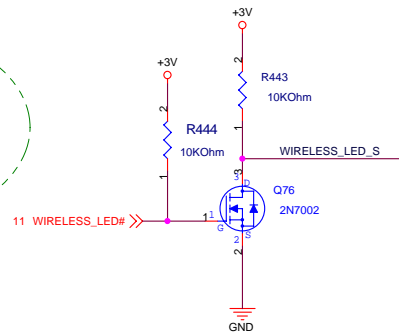
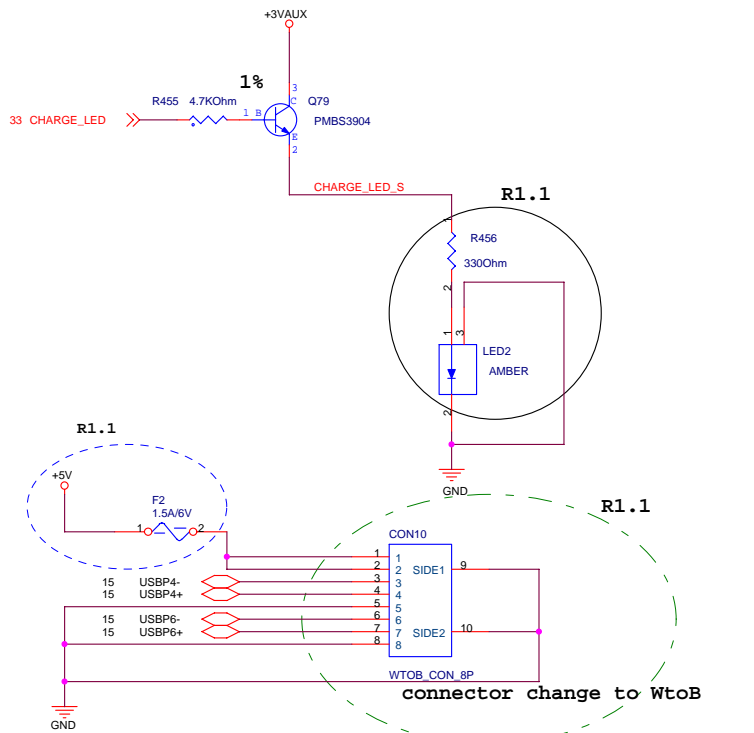
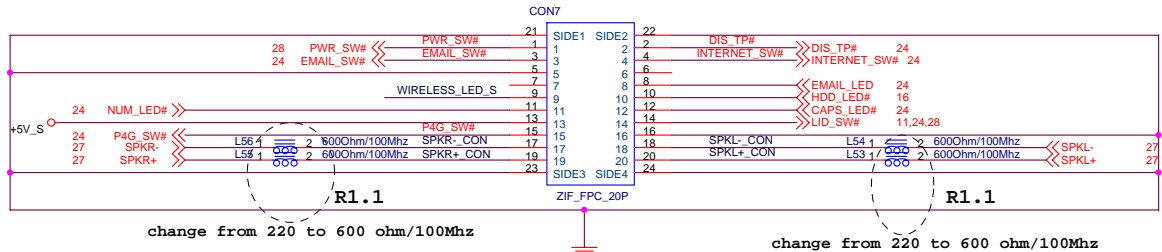
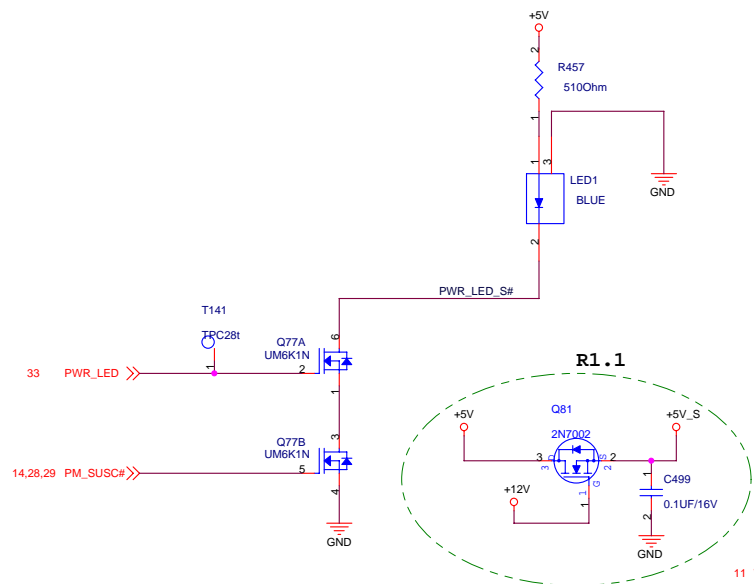

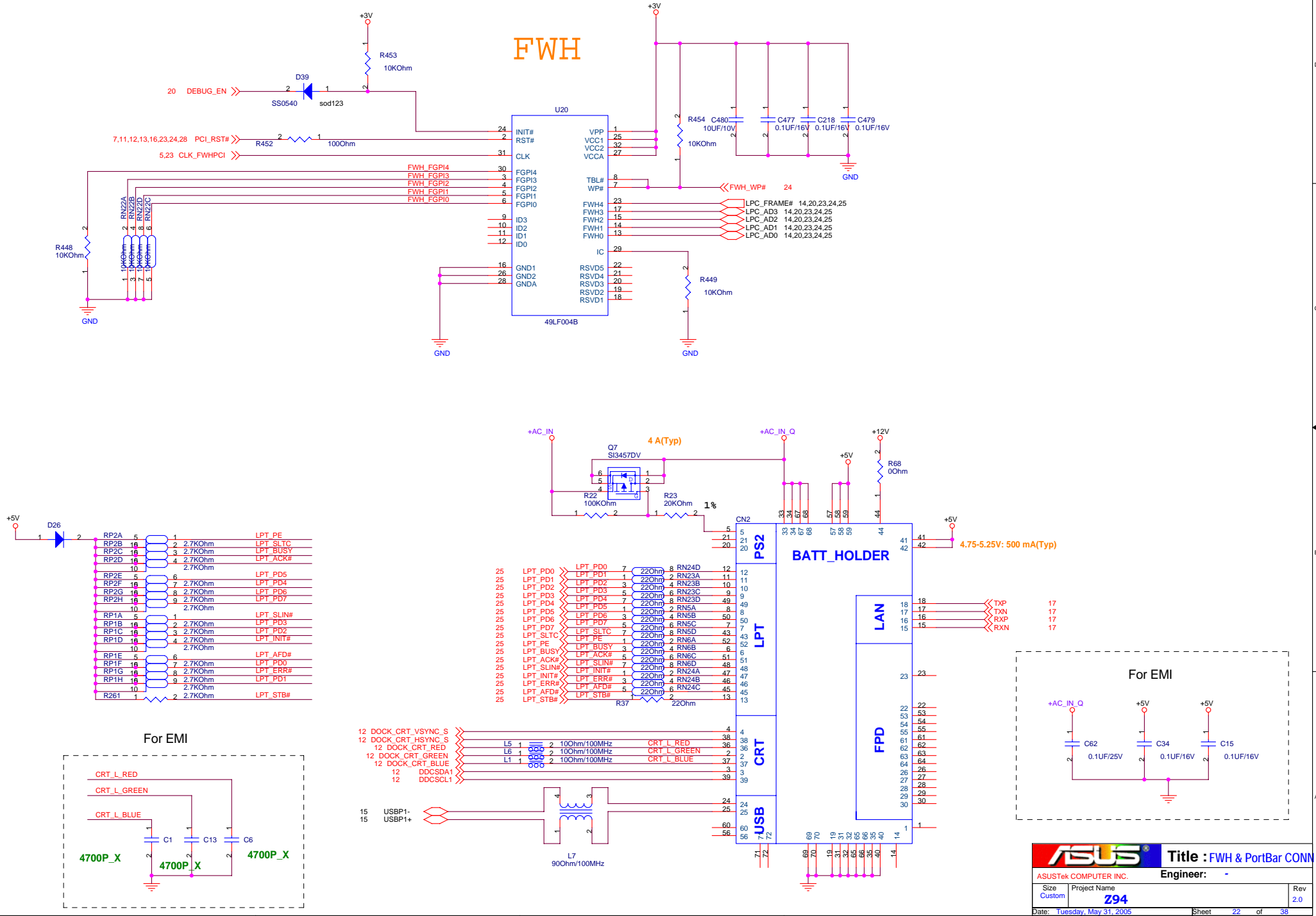

CPU FAN

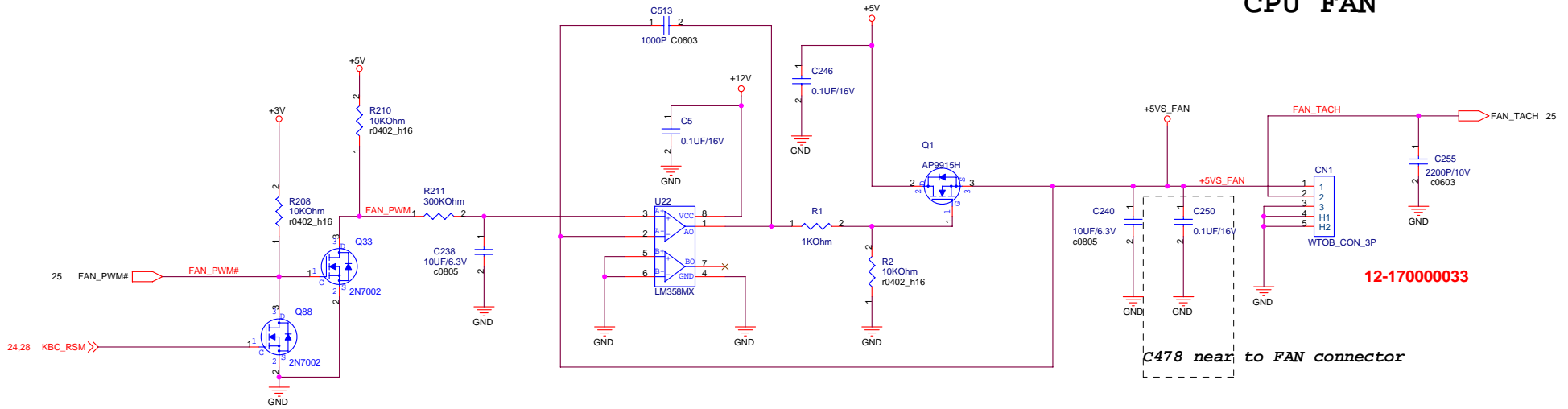

12-17000033

C478 near to FAN connector

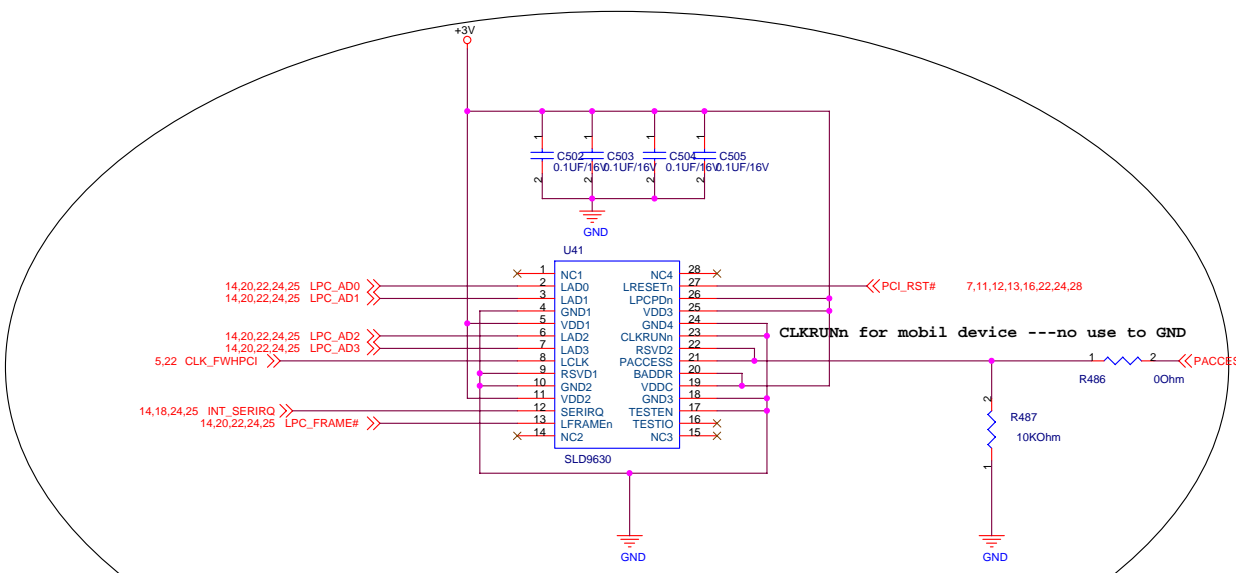

	2Eh/2Fh	4Eh/4Fh
BADDR	GND	VDD

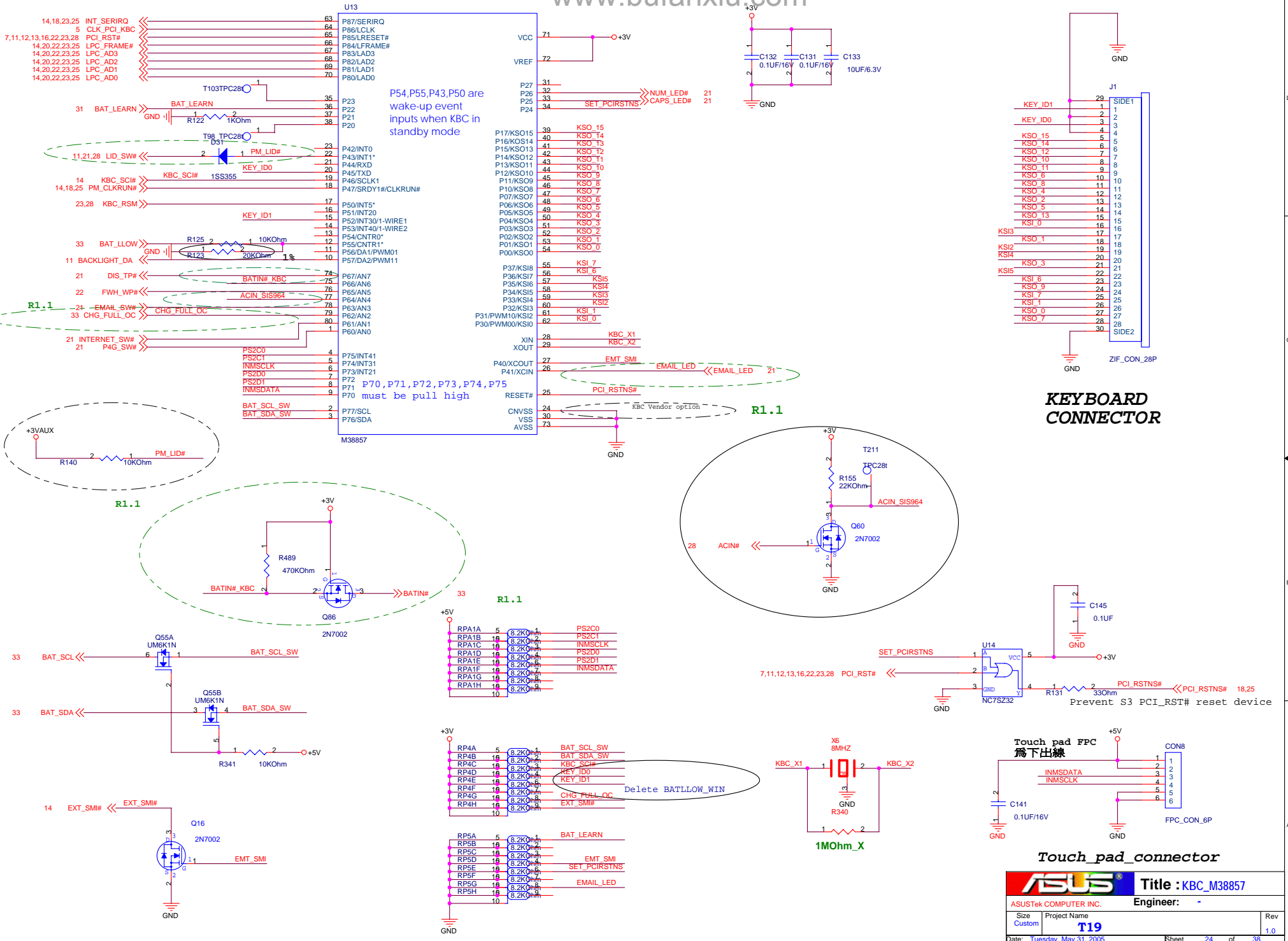

KEYBOARD CONNECTOR

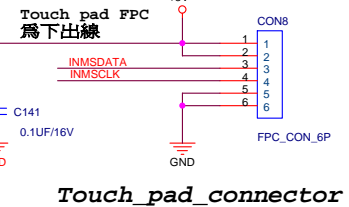

ASUS Title : KBC_M38857

ASUSTek COMPUTER INC. Engineer: -

Size: Custom Project Name: T19

Date: Tuesday, May 31, 2005 Sheet 24 of 38 Rev 1.0

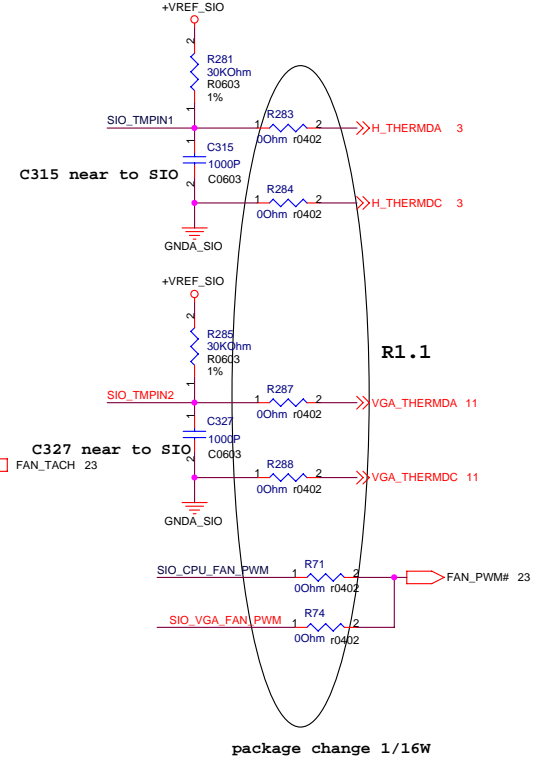
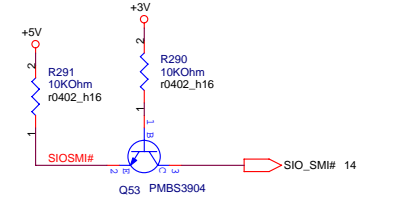
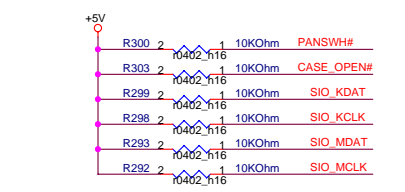
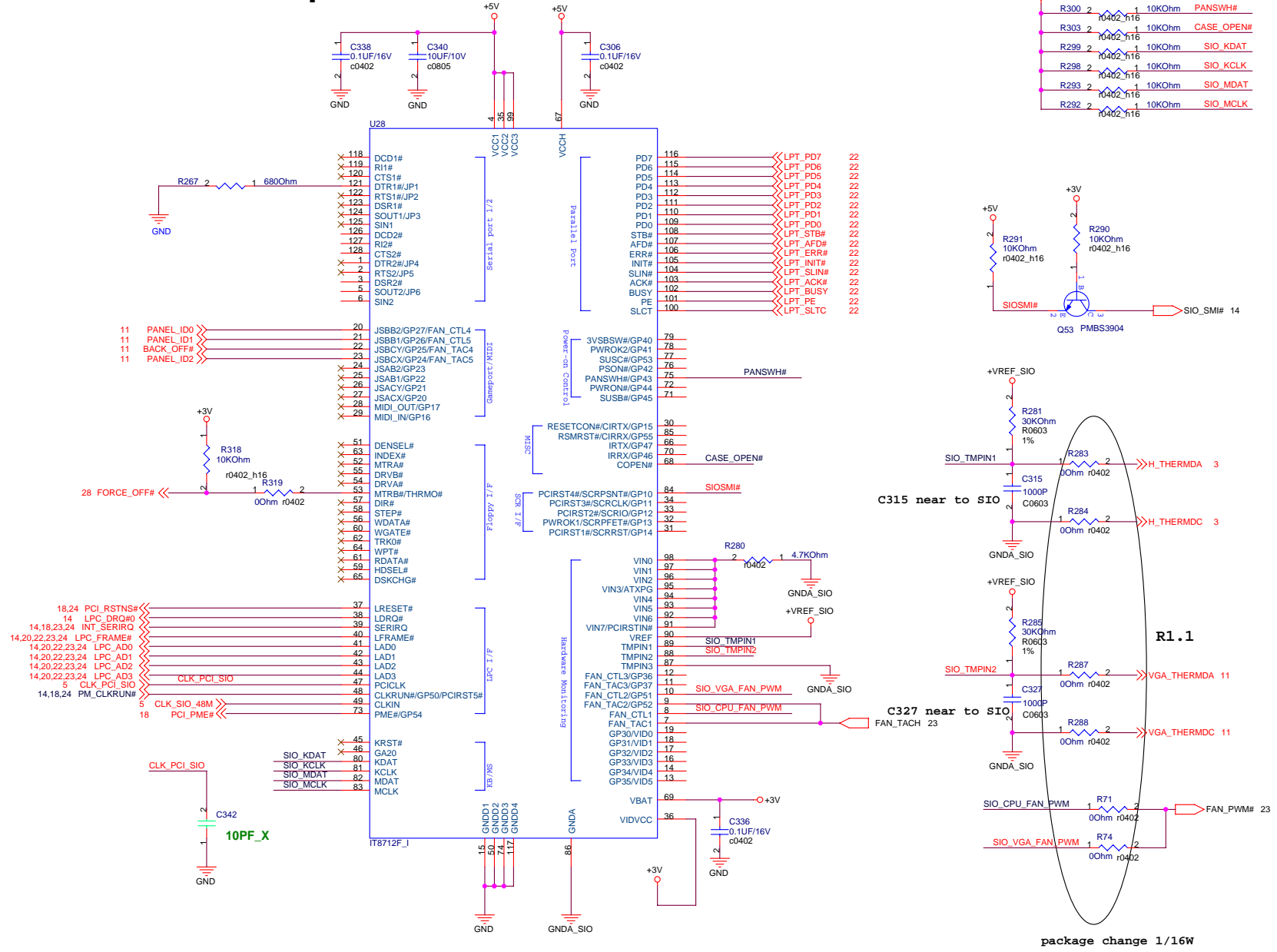

package change 1/16W

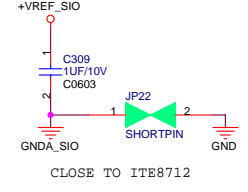

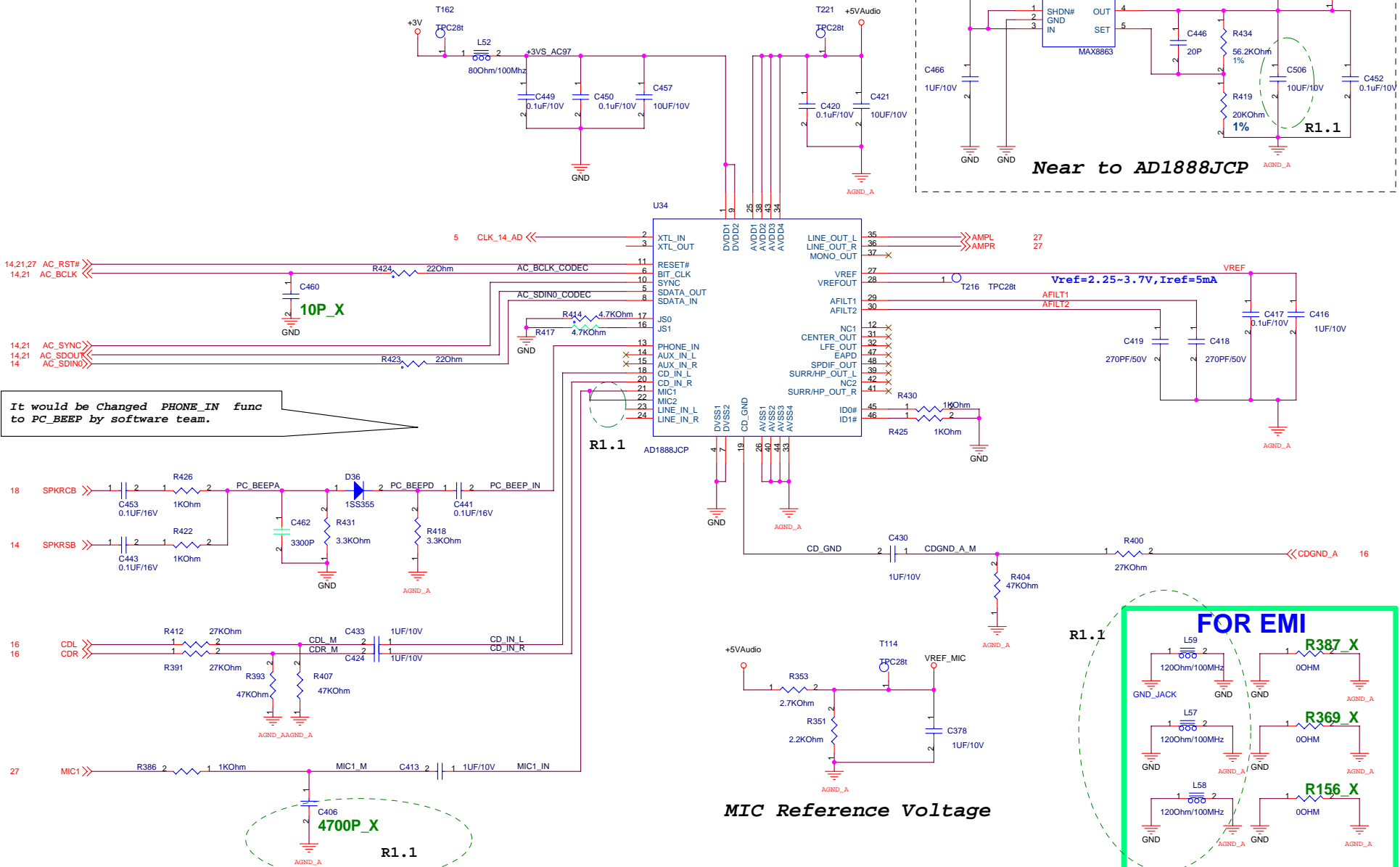

It would be changed PHONE_IN func to PC_BEEP by software team.

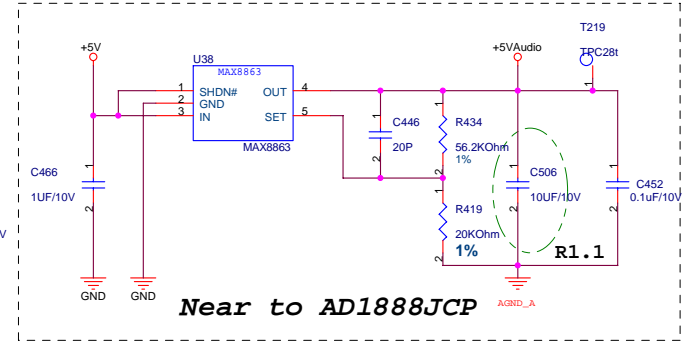

Near to AD1888JCP

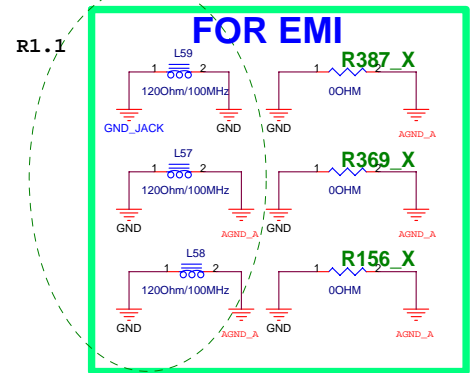

FOR EMI

MIC Reference Voltage

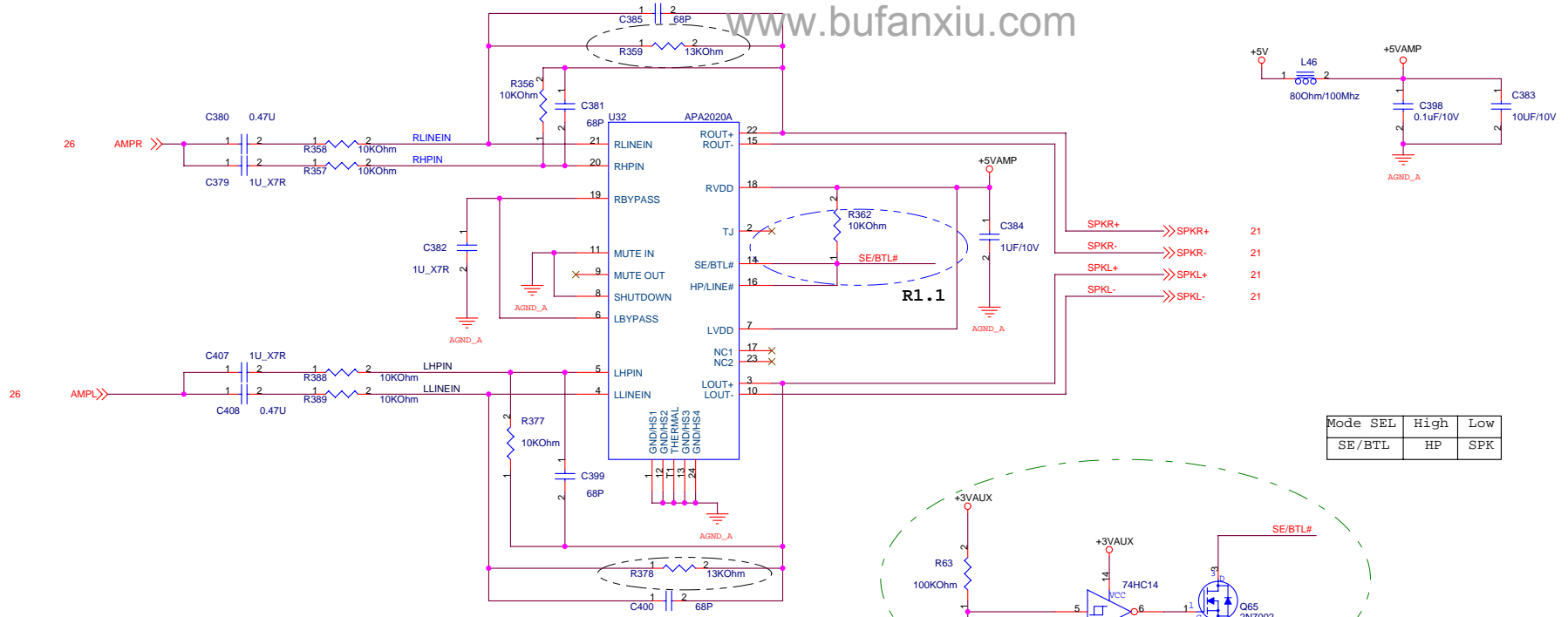

Mode	SEL	High	Low
SE/BTL		HP	SPK

TO PREVENT POP SOUND WHEN SYSTEM WAKE UP FROM S3

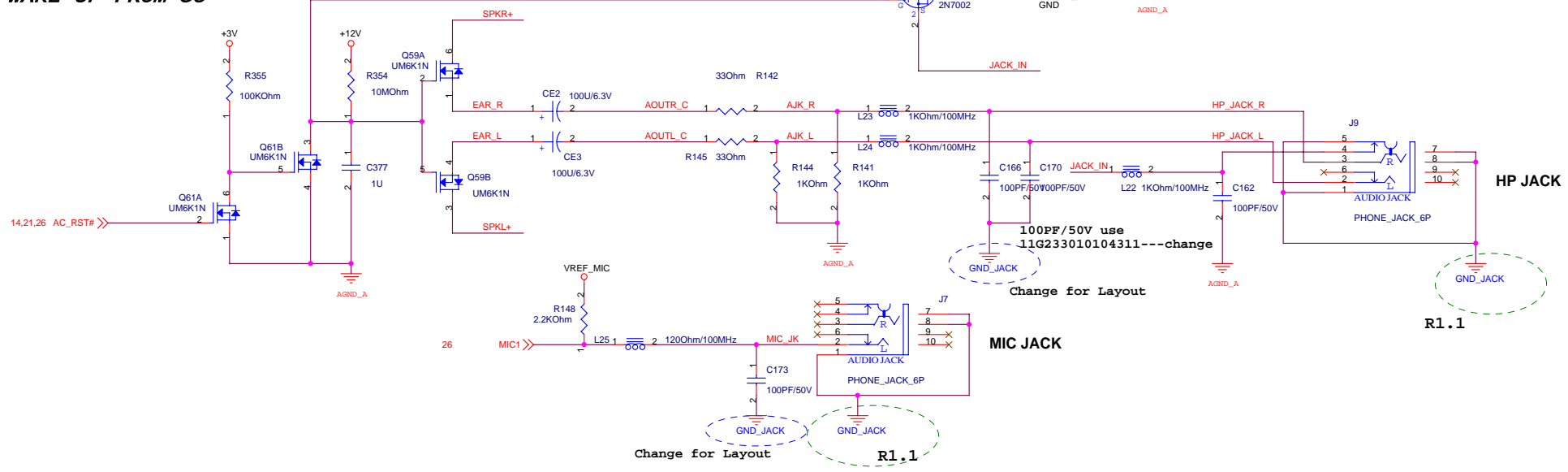
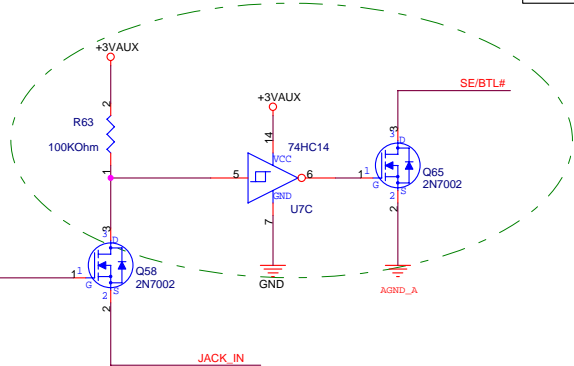

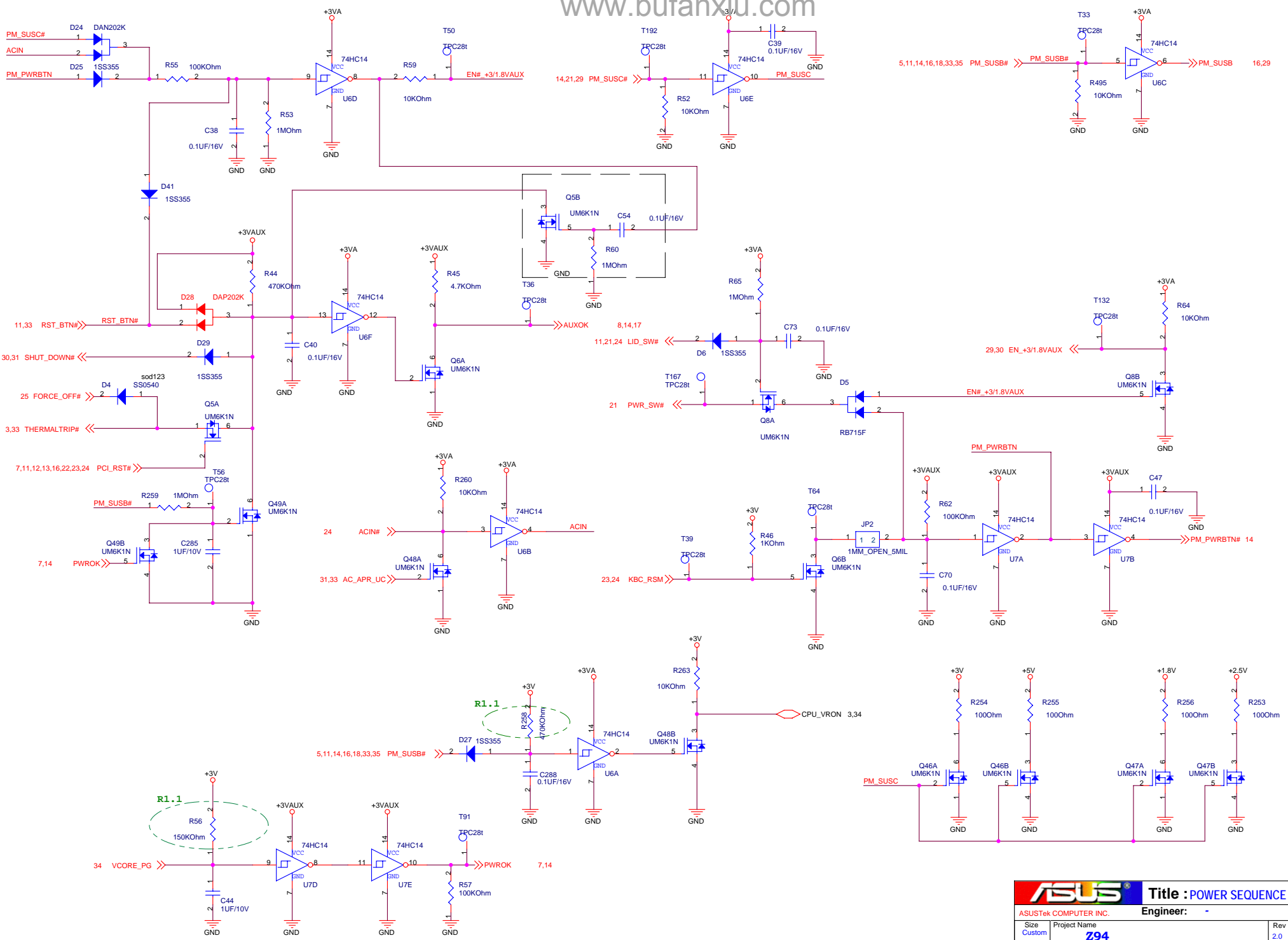

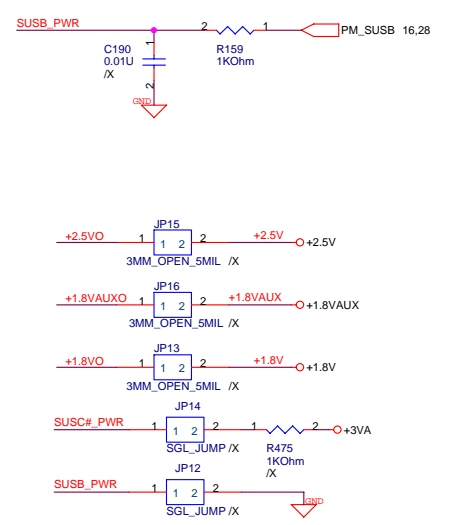
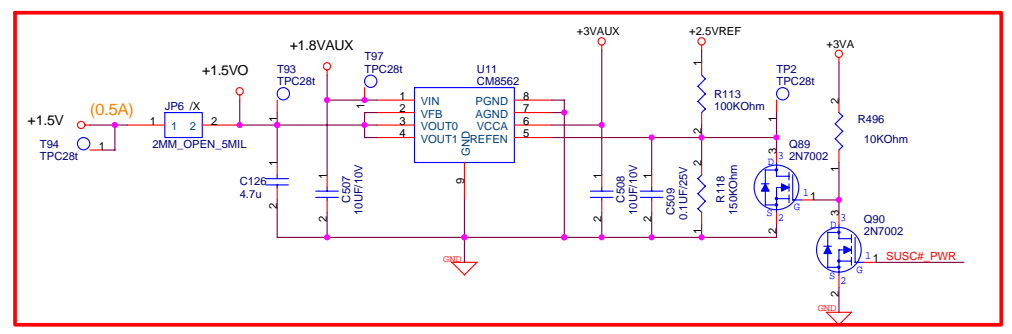
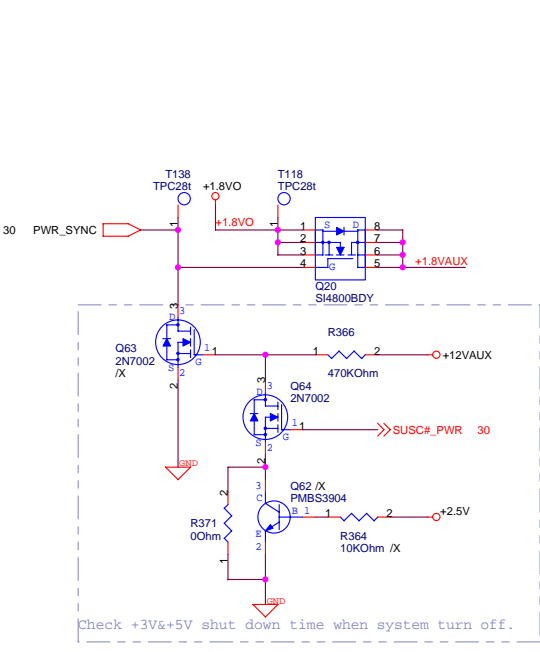
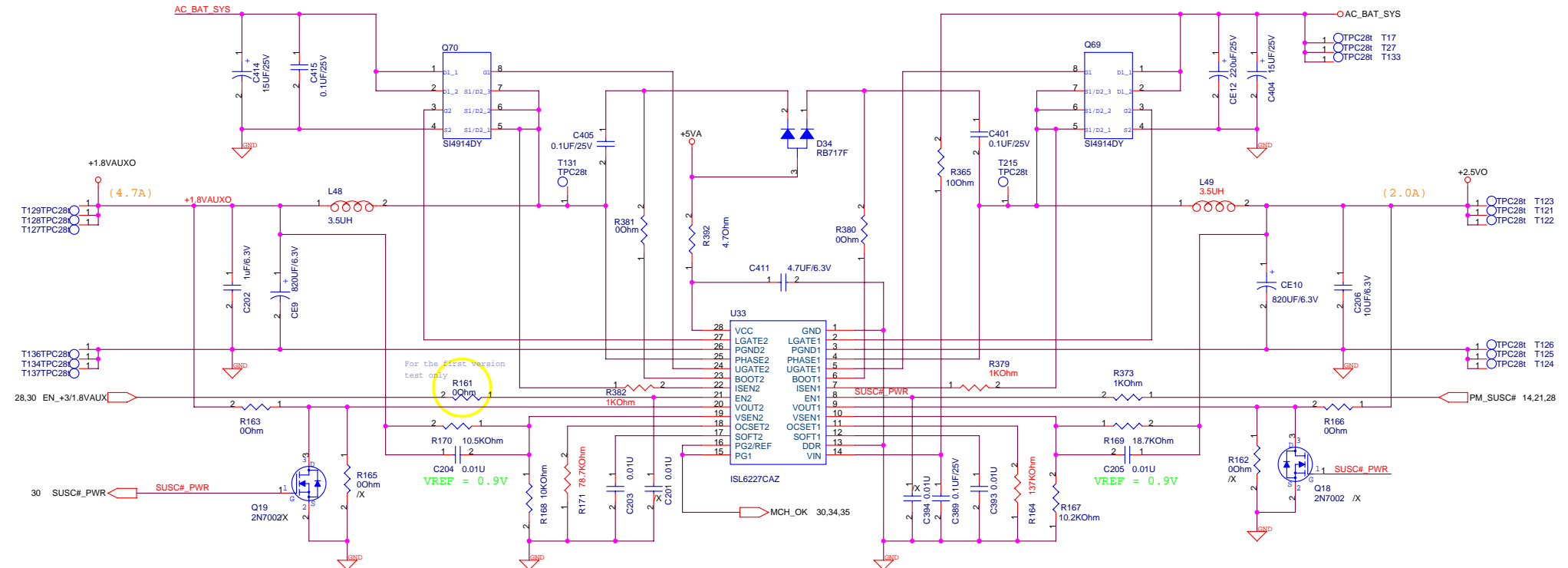

Check +3V/+5V shut down time when system turn off.

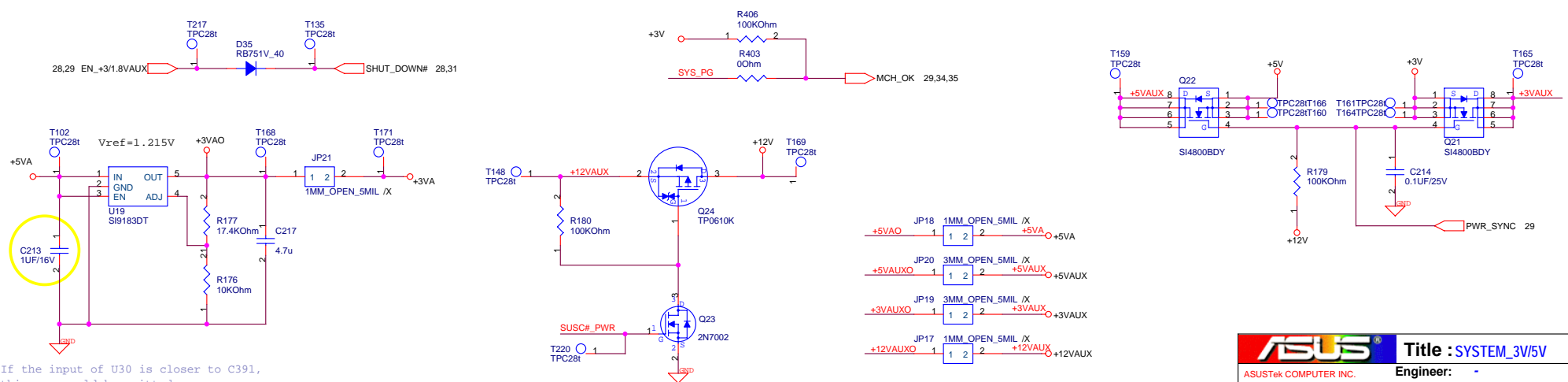
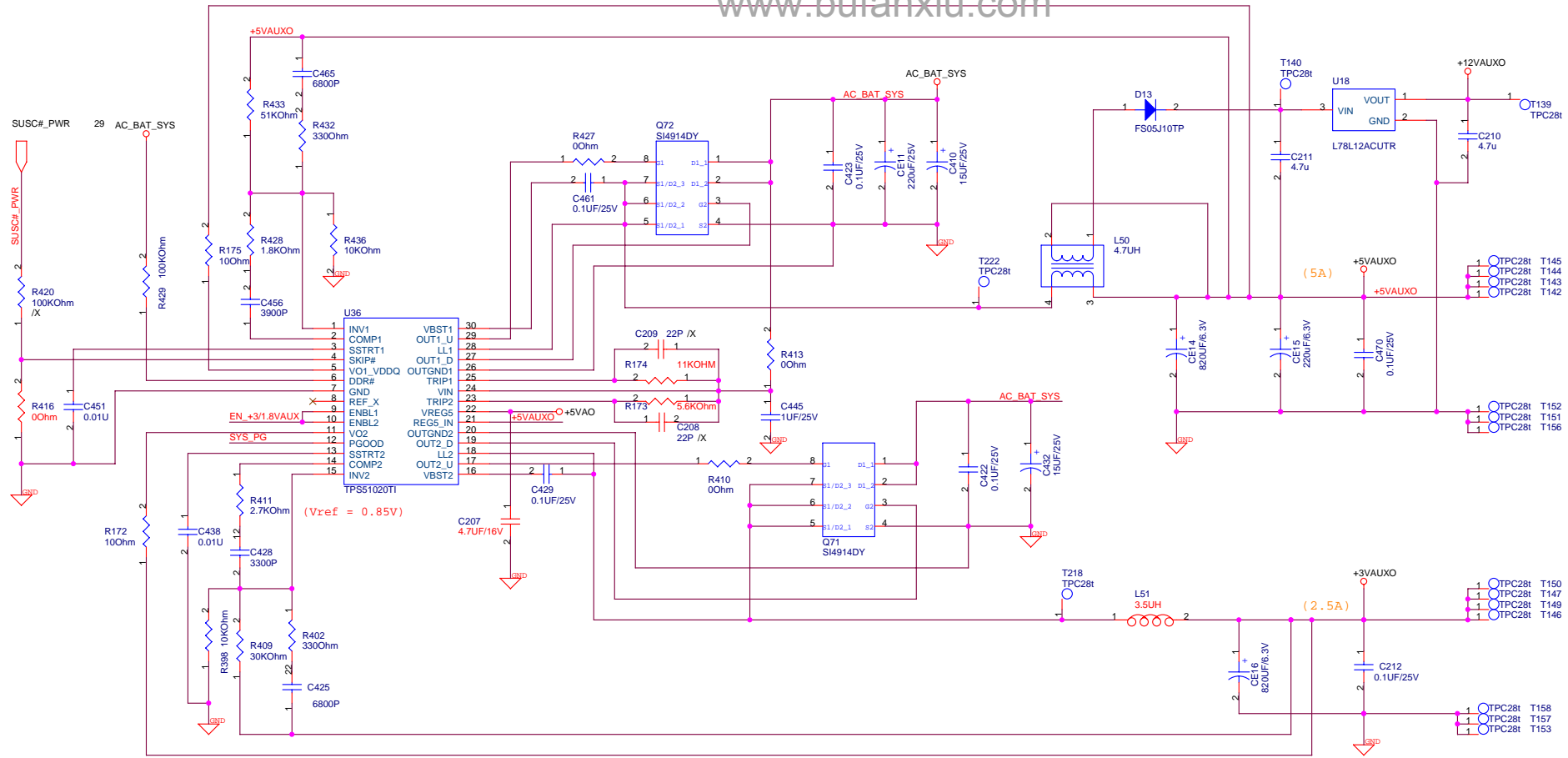

If the input of U30 is closer to C391, this cap could be omitted.

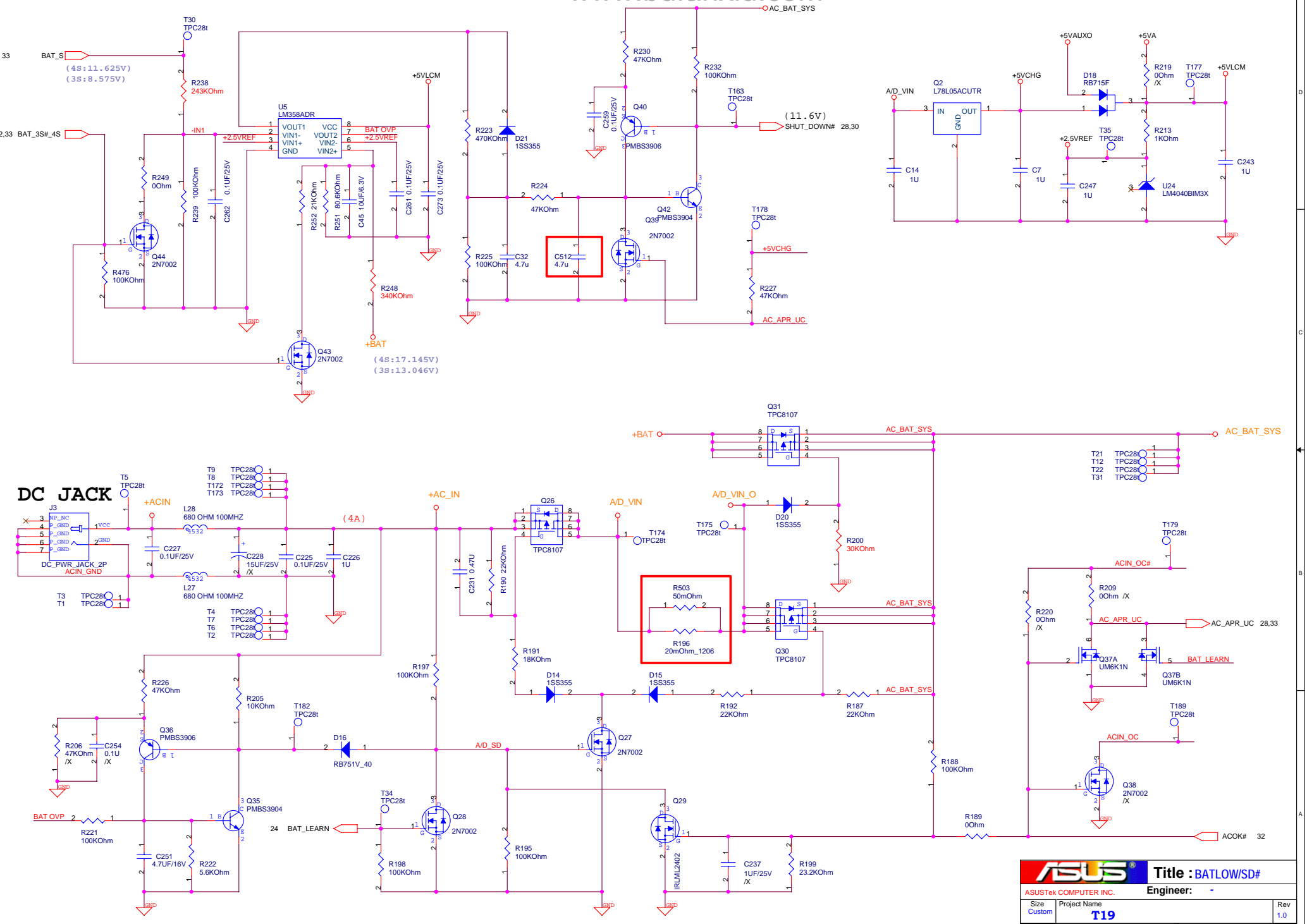

DC JACK

		Title : BATLOW/SD#	
ASUSTek COMPUTER INC.		Engineer: -	
Size Custom	Project Name T19	Date: Tuesday, May 31, 2005	Rev 1.0
		Sheet 31	of 38

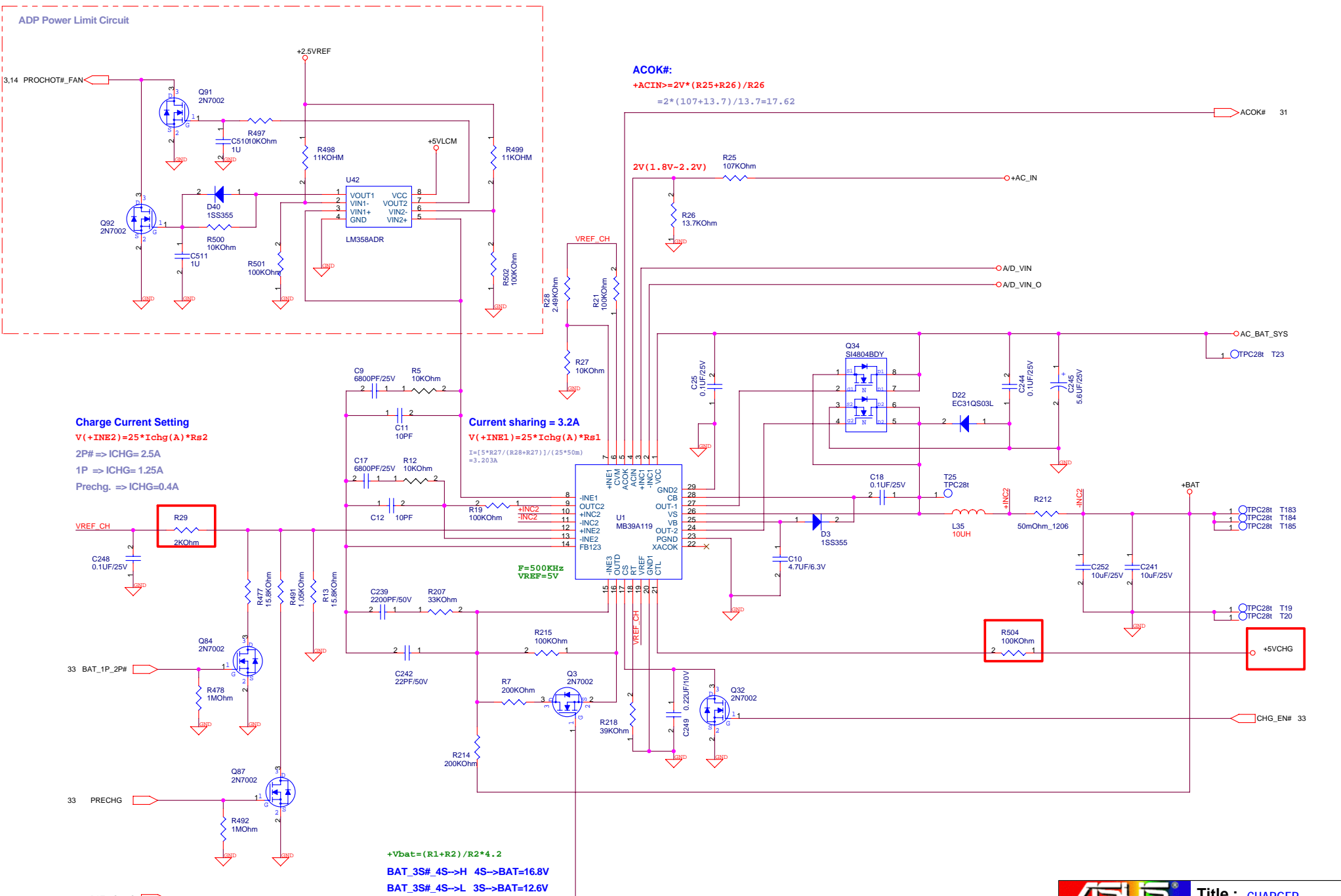

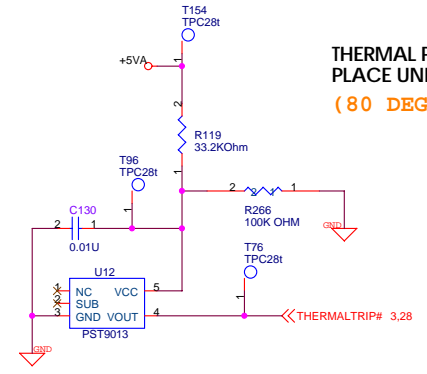
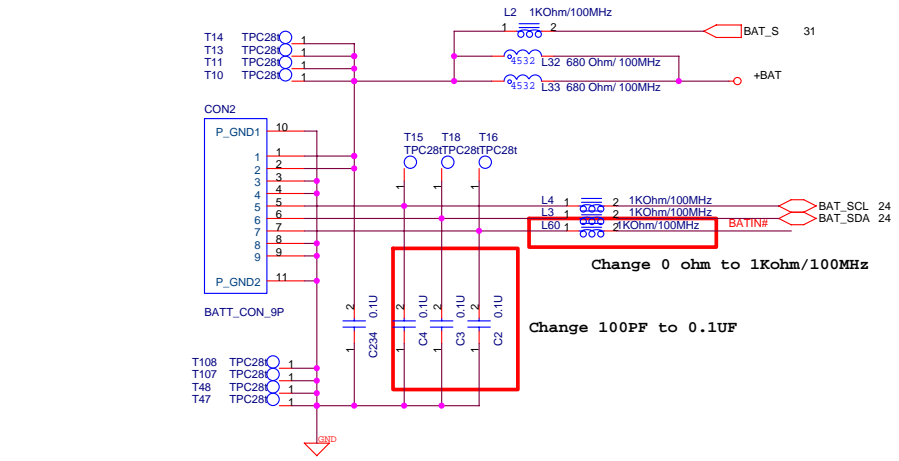
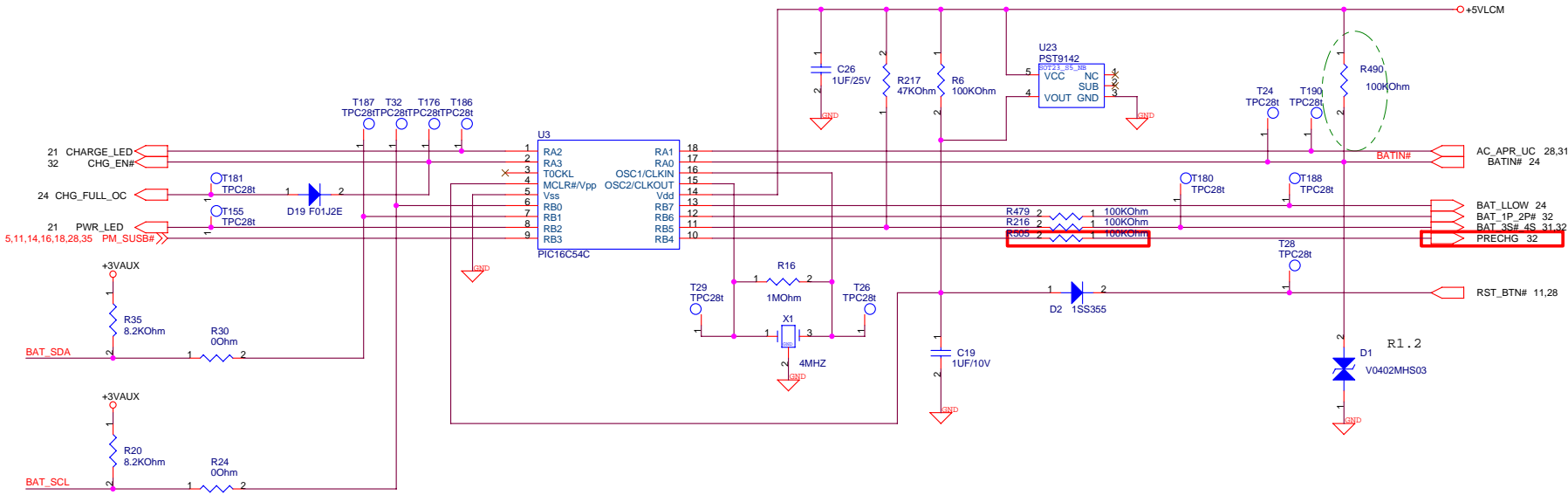

**THERMAL PROTECTION
PLACE UNDER CPU
(80 DEGREE C)**

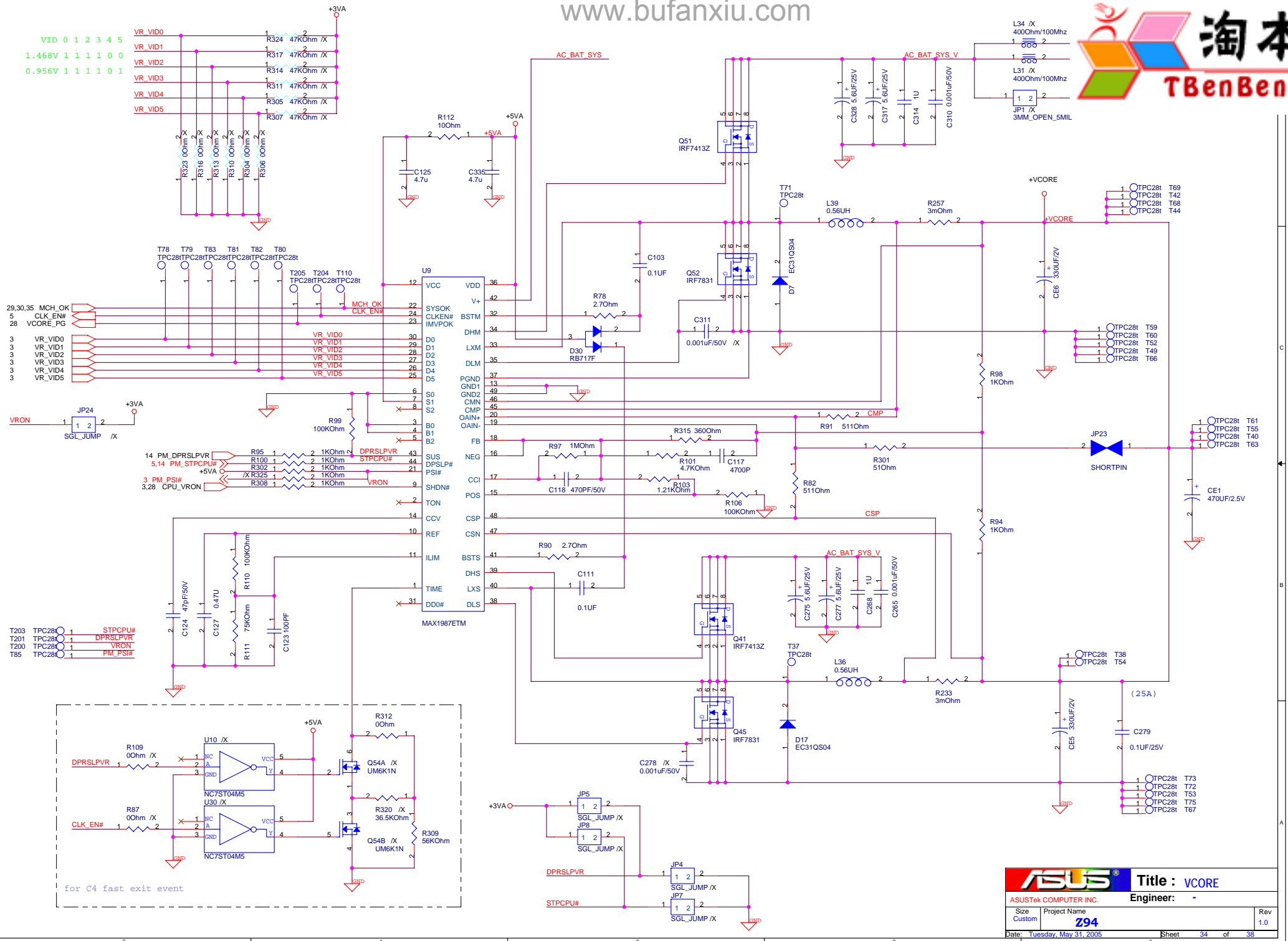

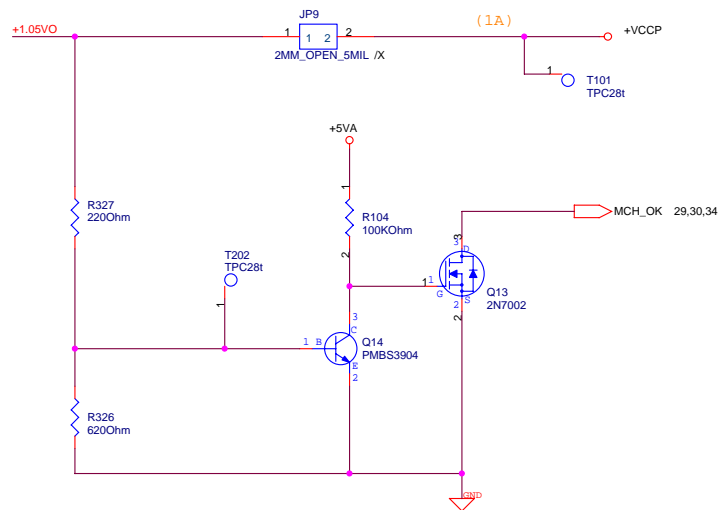
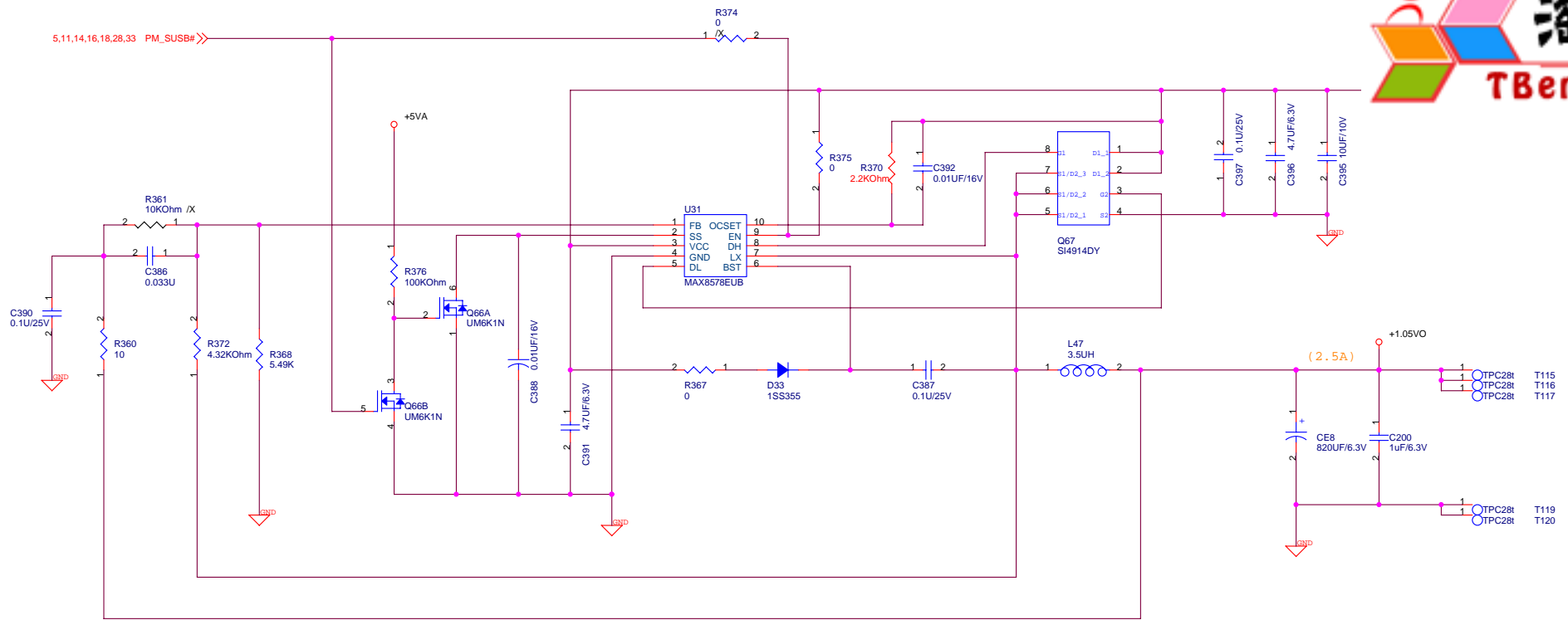

PCI Device	IDSEL#	REQ/GNT#	Interrupts	PC/PCI
Chipset (HOST TO PCI)	(AD11 Internal)			
AGP	(AD16 Internal)		D	
LAN	AD15		D	
HDD	AD13		A	IRQ15
LPC	AD13		C	
MODEM	AD13		C	
AUDIO	AD13		C	
USB	AD14		E,F,G,H	
CardBus	AD19		B,C,D	
ODD	AD13			IRQ14
1394	AD19		B,C,D	

SIS964 GPIO USE AS		
Pin Name	Function	Signal Name
GPIO0	GPI	PACCESS_EN#
GPIO1	GPI	AGP_8XDET#
GPIO2	THERM#	PROCHOT#_FAN
GPIO3	EXTSMI#	EXT_SMI#
GPIO4	CLKRUN#	PM_CLKRUN#
GPIO5	NC	
GPIO6	GPI	THERM#
GPIO7	GPI	ODD_CLR
GPIO8	RING	RIA#
GPIO9	GPI	KBC_SCI#
GPIO10	GPI	SIO_SMI#
GPIO11	STP_PCI#	PM_STPPCI#
GPIO12	CPUSTP#	PM_STPCPU#
GPIO13	DPRSLPVR	PM_DPRSLPVR
GPIO14	AGPSTOP#	AGPSTOP#
GPIO15	VR_HILO#	VR_HI/LO#
GPIO16	NC	
GPIO17	VGATEM#	VGATEM#
GPIO18	NC	
GPIO19	SMC	SMC
GPIO20	SMD	SMD
GPIO21	NC	
GPIO22	NC	
GPIO23	NC	
GPIO24	NC	

SUPER I/O ITE8712F GPIO USE AS					
Pin Name	Function	Signal Name	Default	S3/S4	
GPIO10	GPO	SIOSMI#	High		
GPIO11	NC				
GPIO12	NC				
GPIO13	NC				
GPIO14	NC				
GPIO15	NC				
GPIO16	NC				
GPIO17	NC				
GPIO20	NC				
GPIO21	NC				
GPIO22	NC				
GPIO23	NC				
GPIO24	GPI	PANEL_ID1	High		
GPIO25	GPO	BACK_OFF#	High		
GPIO26	GPI	PANEL_ID1	High		
GPIO27	GPI	PANEL_ID0	High		
GPIO30	GPO	ODD_CLR	LOW		
GPIO31	GPI	ODD_SET	LOW		
GPIO32	NC				
GPIO33	NC				
GPIO34	NC				
GPIO35	NC				
GPIO36	NC				
GPIO37	NC				
GPIO40	NC				
GPIO41	NC				
GPIO42	NC				
GPIO43	PANSWH#	PANSWH#	High		
GPIO44	NC				
GPIO45	NC				
GPIO46	NC				
GPIO47	NC				
GPIO50	CLKRUN#	PM_CLKRUN#			
GPIO51	FAN_CLT2	SIO_VGA_FAN_PWM			
GPIO52	FAN_TAC2	FAN_TACH			
GPIO53	NC				
GPIO54	PME#	PCI_PME#			
GPIO55	NC				

KBC GPIO USE AS				
Pin Name	Function	Signal Name	Default	S3/S4
P20	NC			
P21	GPI		Low	
P22	GPO	BAT_LEARN	Low	Low
P23	NC			
P24	GPO	SET_PCIRSTNS	Low	High
P25	LEDCAP	CAPS_LED#	High	High
P26	LEDNUM	NUM_LED#	High	High
P27	SCROLL	SCROLL_LED#	High	High
P40	GPO	EMT_SMI	Low	Low
P41	GPO	EMAIL_LED	Low	Low
P42	NC			
P43	GPI	PM_LID#	High	High
P44	NC			
P45	GPI	KEY_ID0		
P46	SCI	KBC_SCI#		
P47	CLKRUN#	PM_CLKRUN#		
P50	GPO	KBC_RSM	Low	Low
P51	NC			
P52	GPI	KEY_ID1		
P53	NC			
P54	NC			
P55	GPI	BAT_LLOW		
P56	NC			
P57	GPO	BACKLIGHT_DA	anlog	anlog
P60	GPI	P4G_SW#		
P61	GPI	INTERNET_SW#		
P62	GPI	CHG_FULL_OC	Low	
P63	GPI	EMAIL_SW#		
P64	GPI	ACIN_SIS964	Low	
P65	GPO	FWH_WP#	High	High
P66	GPI	BATIN#_KBC	High	
P67	GPI	DIS_TP#		

SM BUS Address		
BUS name	Address	Device
Thermal controller	2E	ADT7460ARQ
Clock GEN	D2	ICS950816
DDR Clock	D4	ICS93732



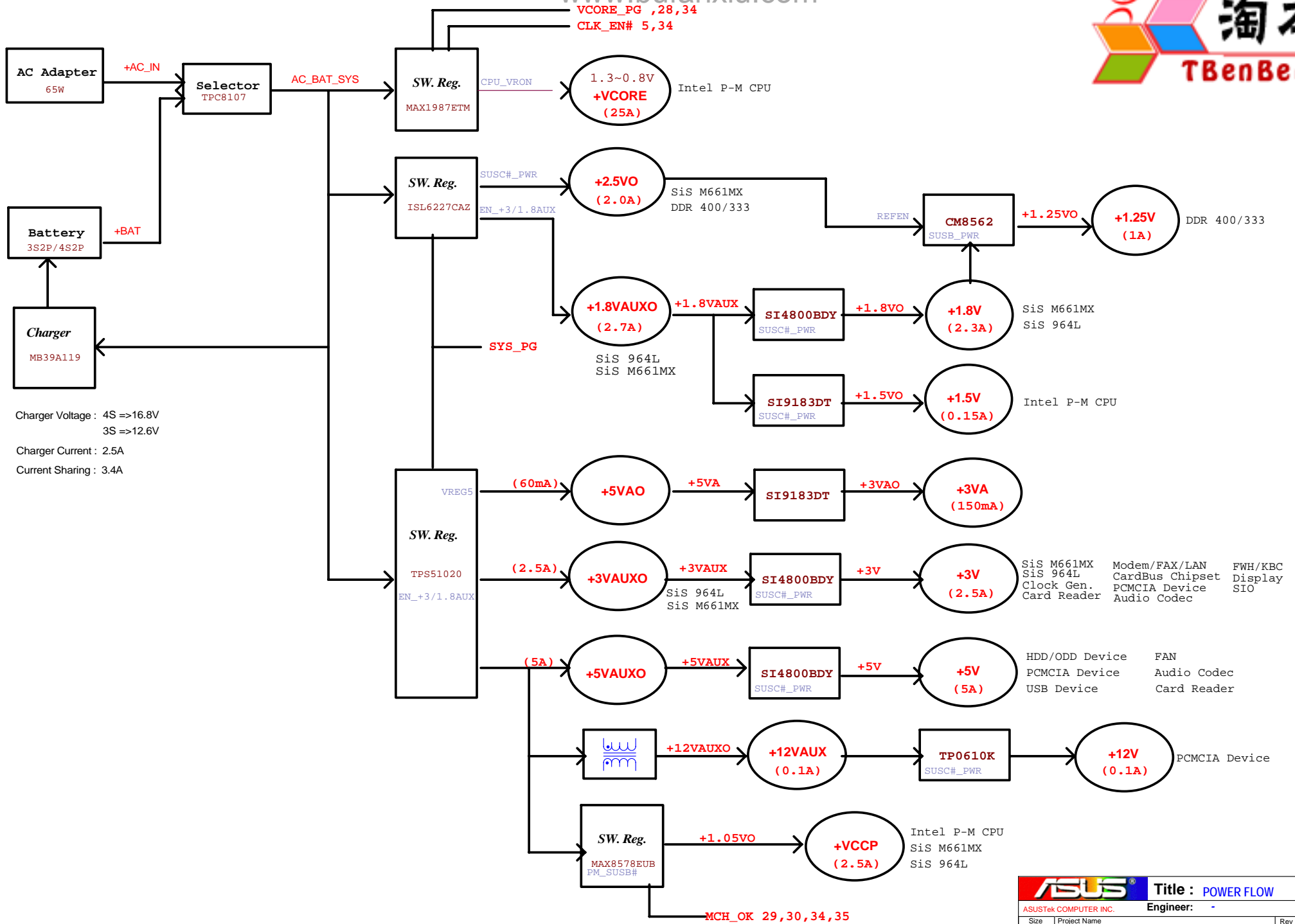

Charger Voltage : 4S =>16.8V
 3S =>12.6V
 Charger Current : 2.5A
 Current Sharing : 3.4A



- 1.change page3 R10 from 20K 5% to 20K 1%.
- 2.page5 change R335,R328,R334 from 0 ohm to 33 ohm and delete C347,C349,C351,C354 5P capacitor.
- 3.Change page5 BSEL circuit
- 4.Page6 AGP_VREF add AGP bus reference voltage R465,R466 with 2.32 ohm 1%
- 5.Page6 AGP_8XDET# cancel connect(pull high only)
- 6.Page11 add AGP_8XDET# R493 pull high 3V.
Add net RST_BTN.
- 7.Page14 change RXD0 damp resistor near to U4 source.
- 8.Page 14 change ACIN_SIS964 to KBC GPIO64.
- 9.Page 14 change BATIN# to KBC GIP066
- 10.Page 14 change SIO_SMI# from SIS964 GPIO16 to GPIO10.
- 11.Page 14 add SIS964 GPIO7 pull high
- 12.Page 14 change CHG_FULLL_OC from SIS964 GPIO18 to KBC GPIO62.
- 13.Page 14 change PM_LID# from SIS964 GPIO7 to KBC GPIO43.
- 14.Page 15 SIS964 UVDD33_1~3 power change to USBCOMPVDD.
- 15.Page 16 add ESD protection D42,D43
- 16.Page 17 RJ45 LAN pin difine inverse
- 17.Page 20 change R262 from 10K to 100K ohm to reduce delay time.
- 18.Page 21 add MOS to switch +5V ensure +5V will not sink current when USB device plug in.
- 19.Page 22 change R456 from 1.3K to 330 ohm..
- 20.Page 23 add TPM solution..
- 21.Page 24 add MUTI function EMAIL_LED and SCROLL_LED.
- 22.Page 24 add KBC pin24 to GND for KBC select.
- 23.Page 26 change from TAN_capacitor to ceramic.
- 24.Page 27 change SE/BTL select.
- 25.Page 26 add CODEC pin 22(MIC2) conect pin 21
- 26.Page 28 change R258 from 100K to 470K for power sequence.
- 27.Page 28 change R258 from 10K to 150K for power sequence.
- 28.Page 27 Jack GND net change to GND_JACK for EMI
- 29.Page 26 add L57,L58,L59 for EMI
- 30.Page 26 add L57,L58,L59 for EMI
- 31.Page 21 change CPU hole H4,H5,H6,H7 NPTH to PTH and add J10 spring for EMI
- 32.Page 21 add FUSE F2 and L53,L54,L55,L56 change to 600ohm/100MHz
- 33.Page 21 change CPU hole H4,H5,H6,H7 NPTH to PTH and add J10 spring for EMI
- 34.Page 3 Q4 N-MOSFET change to drain connect R31 pin1 source connector GND
- 35.Page 5 Change C316,C413 from 12PF to 33PF
- 36.Page 14 Change C175,C179 from 18PF to 15PF

		Title : HISTORY	
ASUSTek COMPUTER INC.		Engineer: -	
Size Custom	Project Name Z94	Rev 2.0	
Date: Tuesday, May 31, 2005		Sheet 38 of 38	