

P08B1 Design Document

Rev. SA 11 / 2007

P08B1 Block Diagram

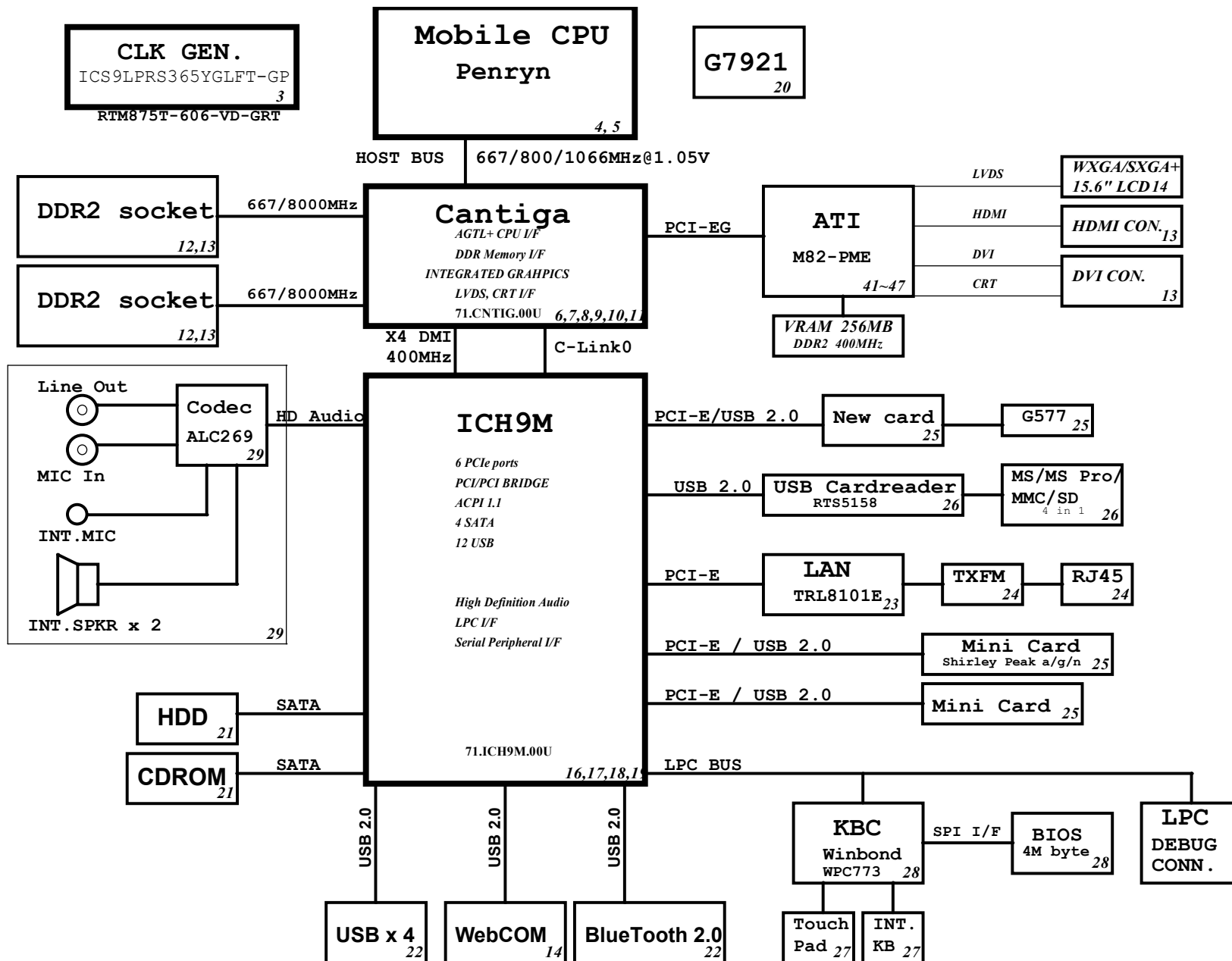

P08B1 Clock Block Diagram

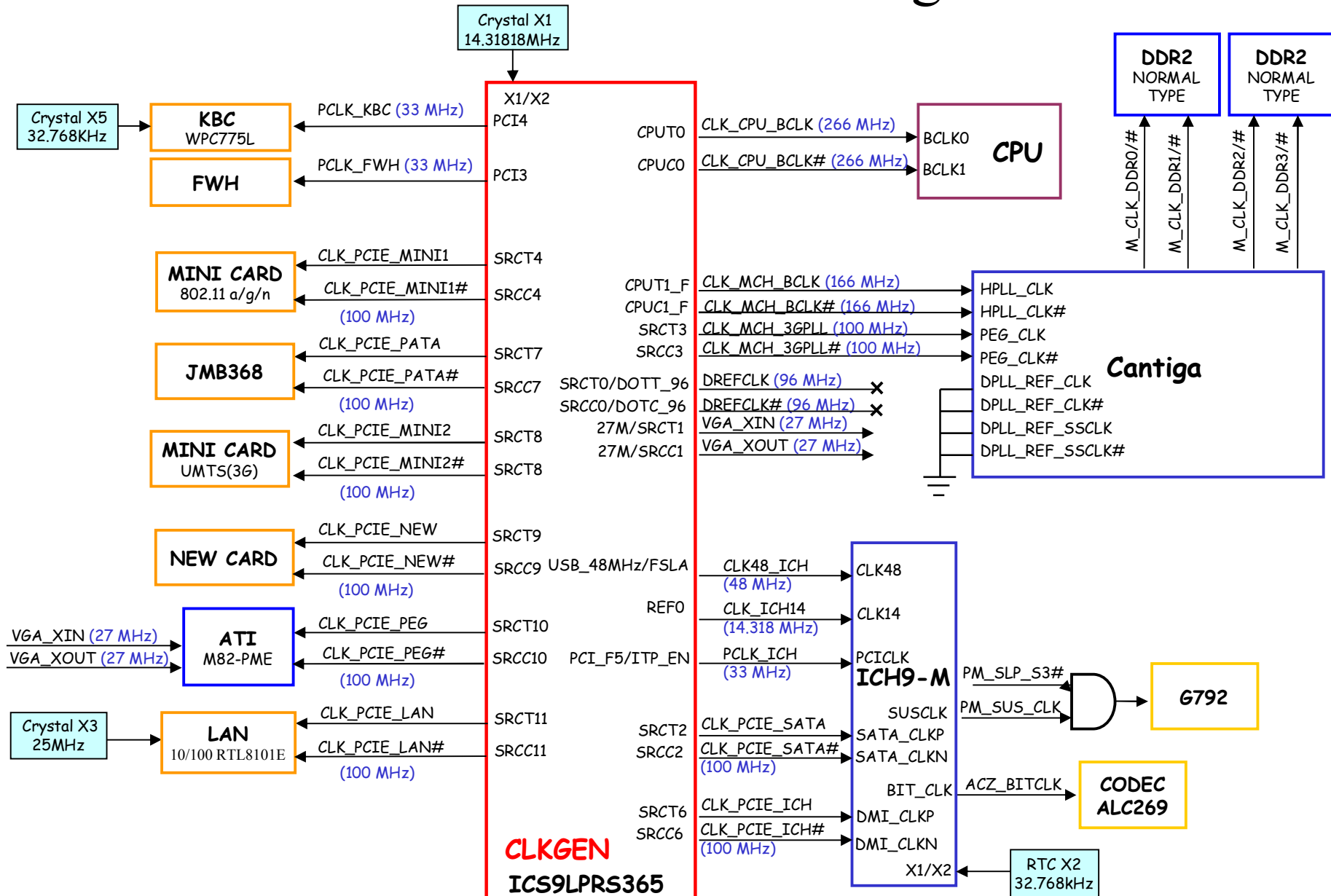

P08B1 Power ON Sequence

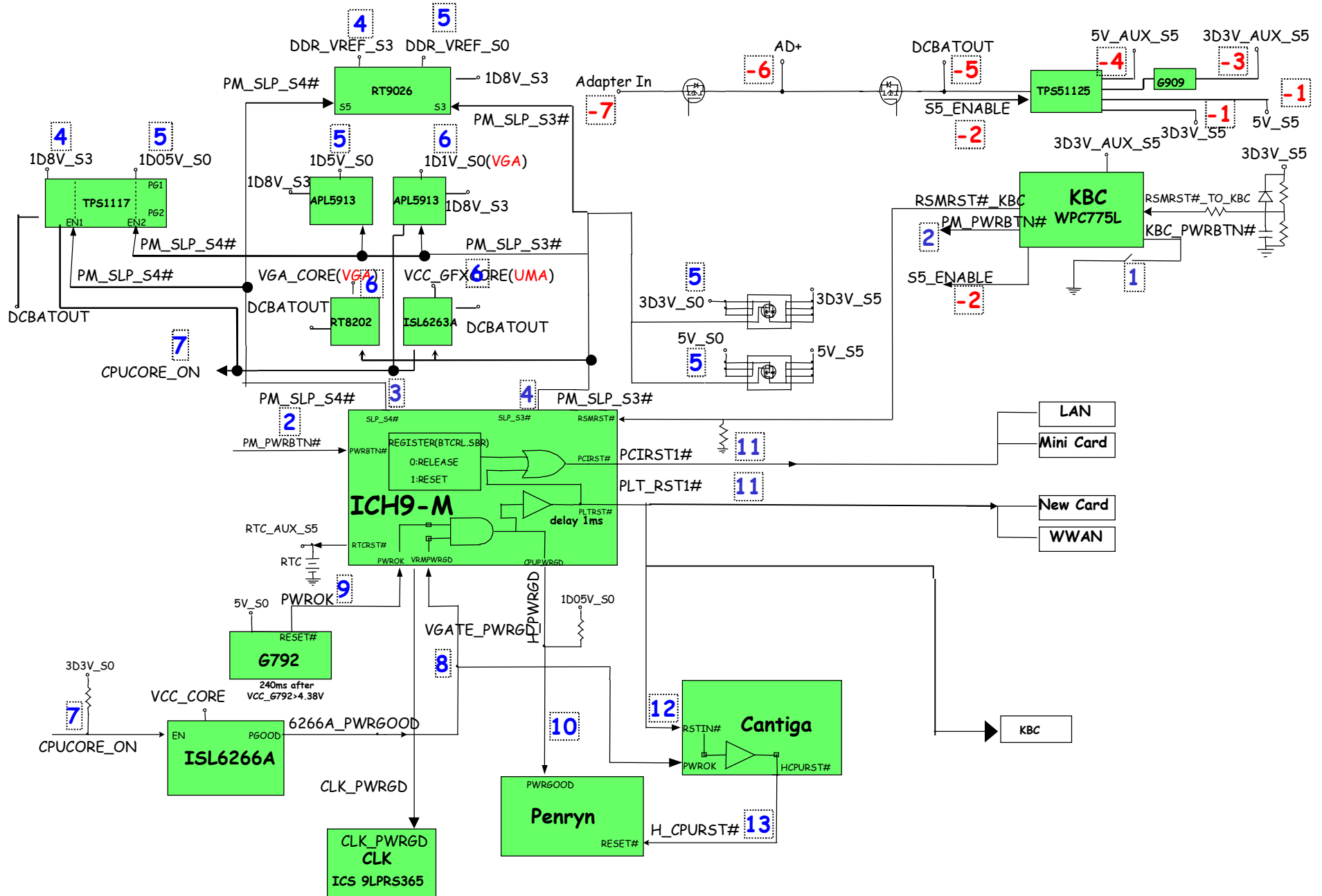

P08B1 Power On/Off Sequence

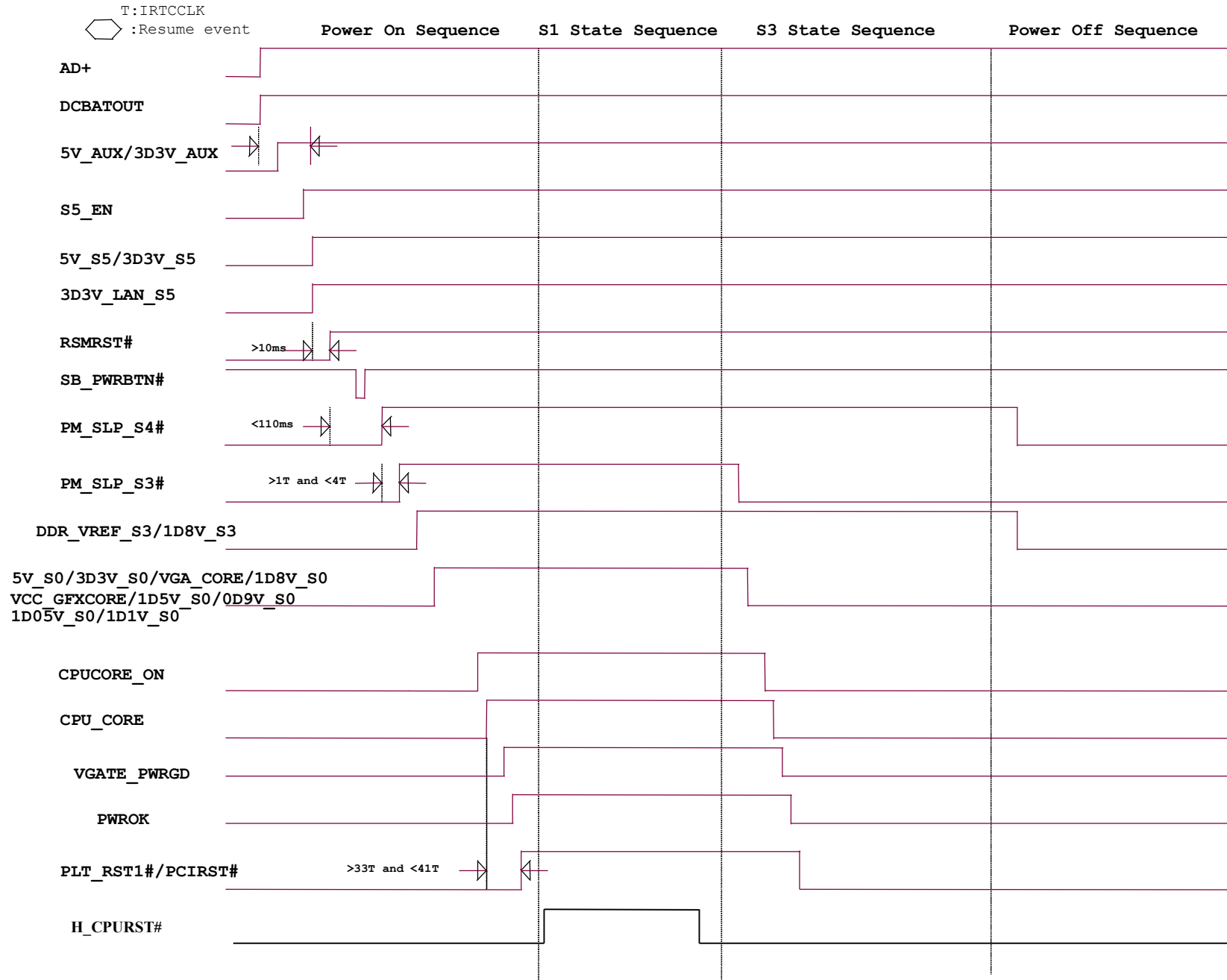

P08B1 Power Block Diagram

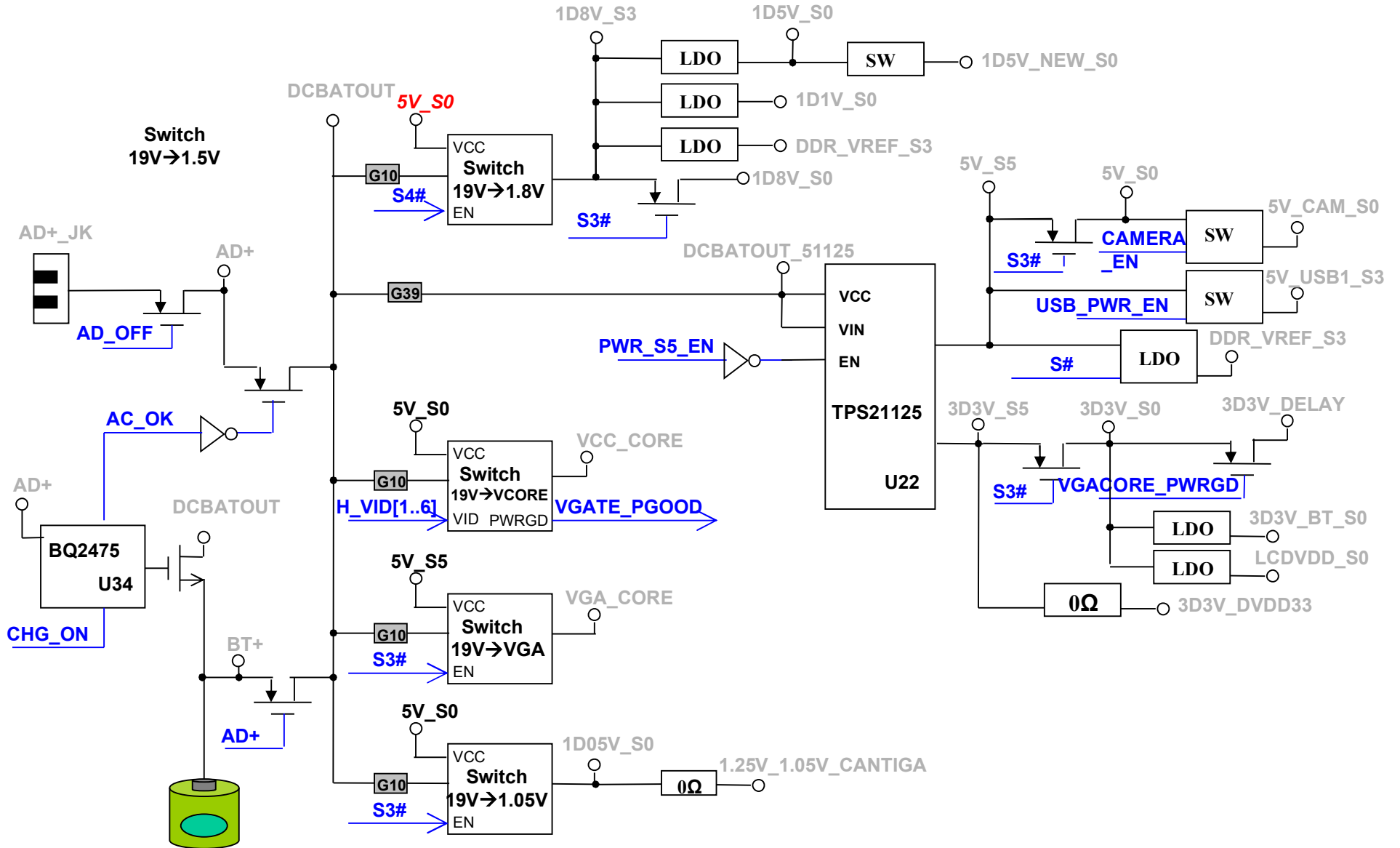

P08B1 Power Budget

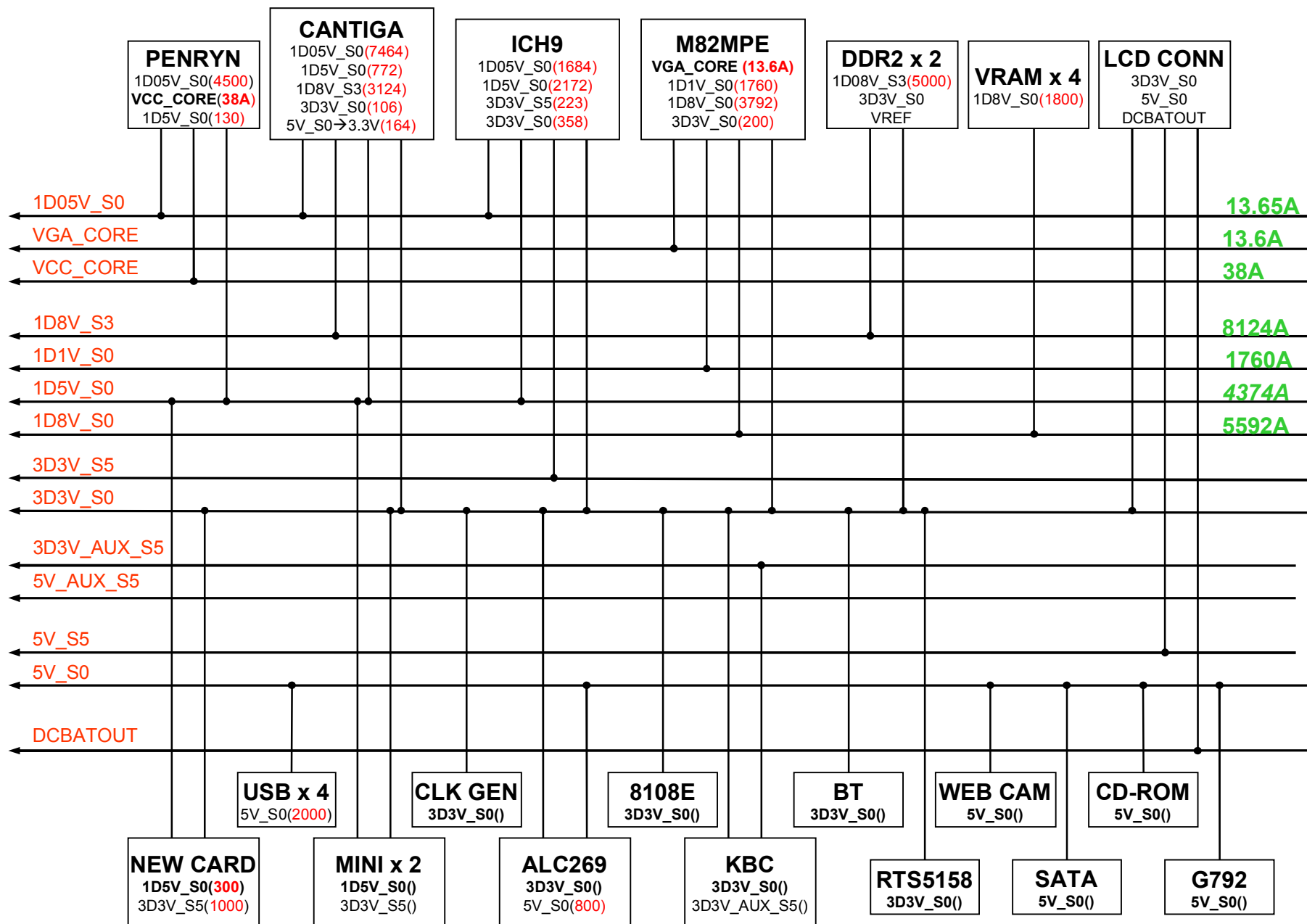

P08B1 Charger Block Diagram

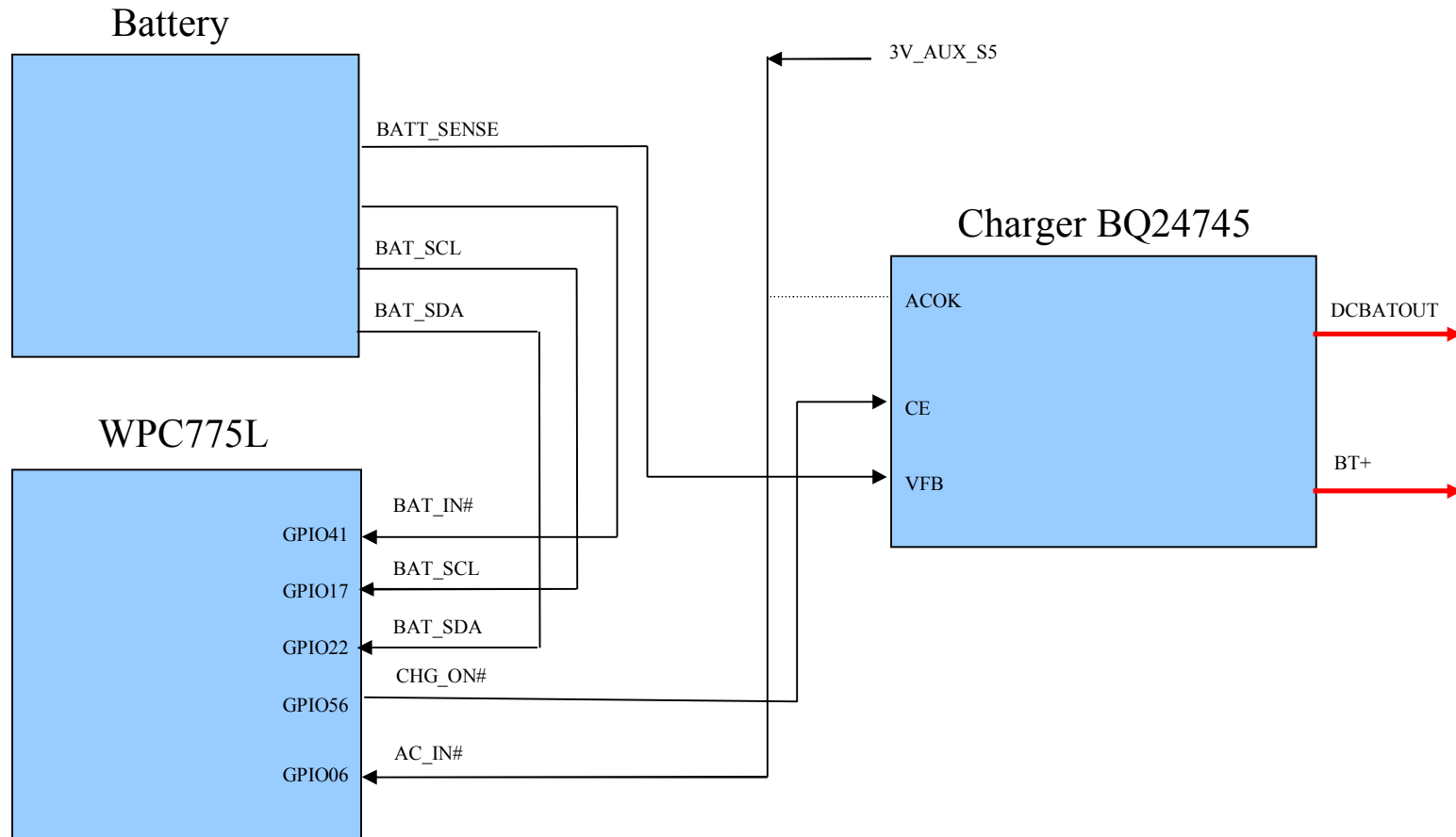

P08B1 VCC_CORE Block Diagram

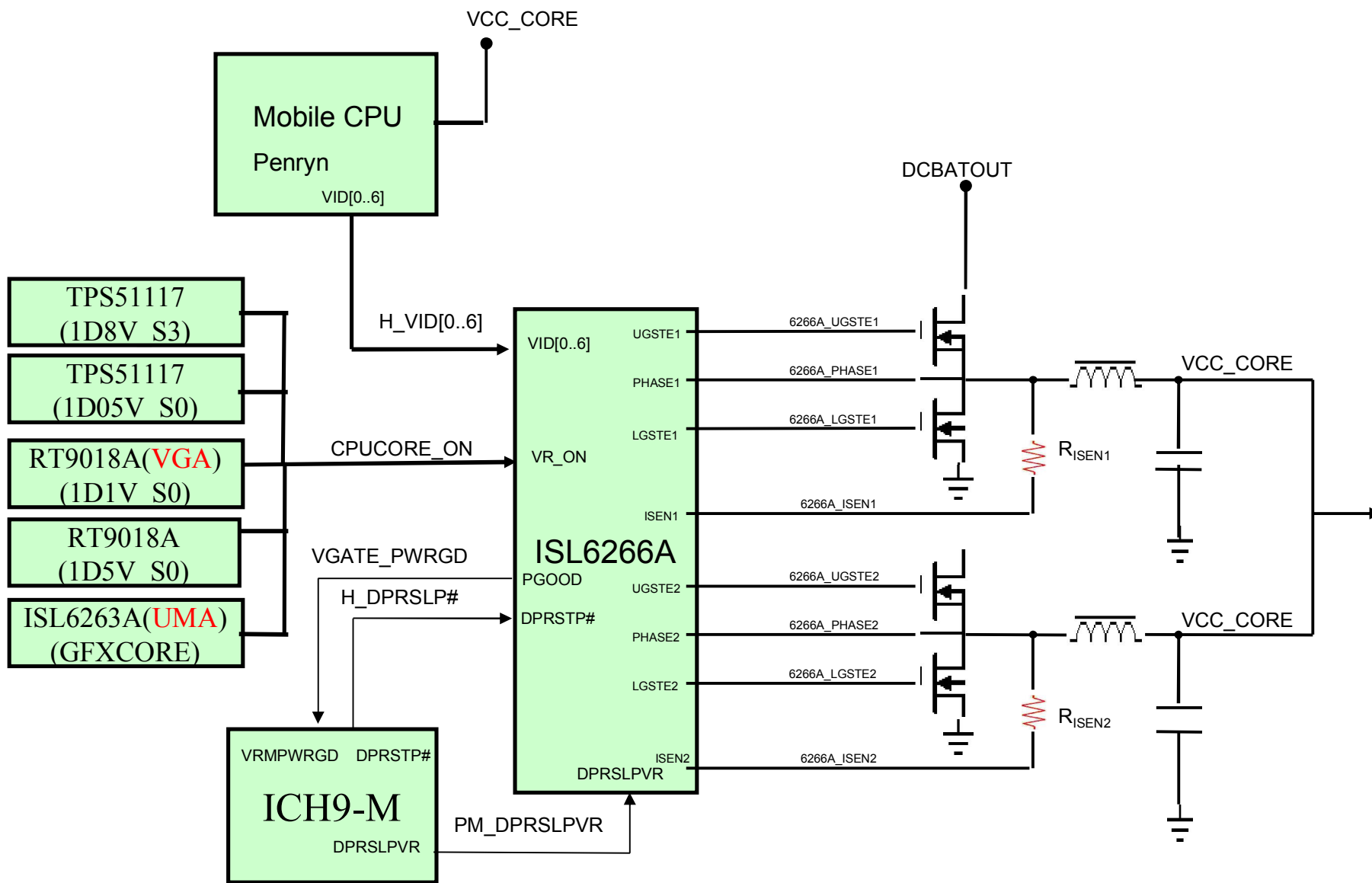

P08B1 SMI/SCI/SWI Interface

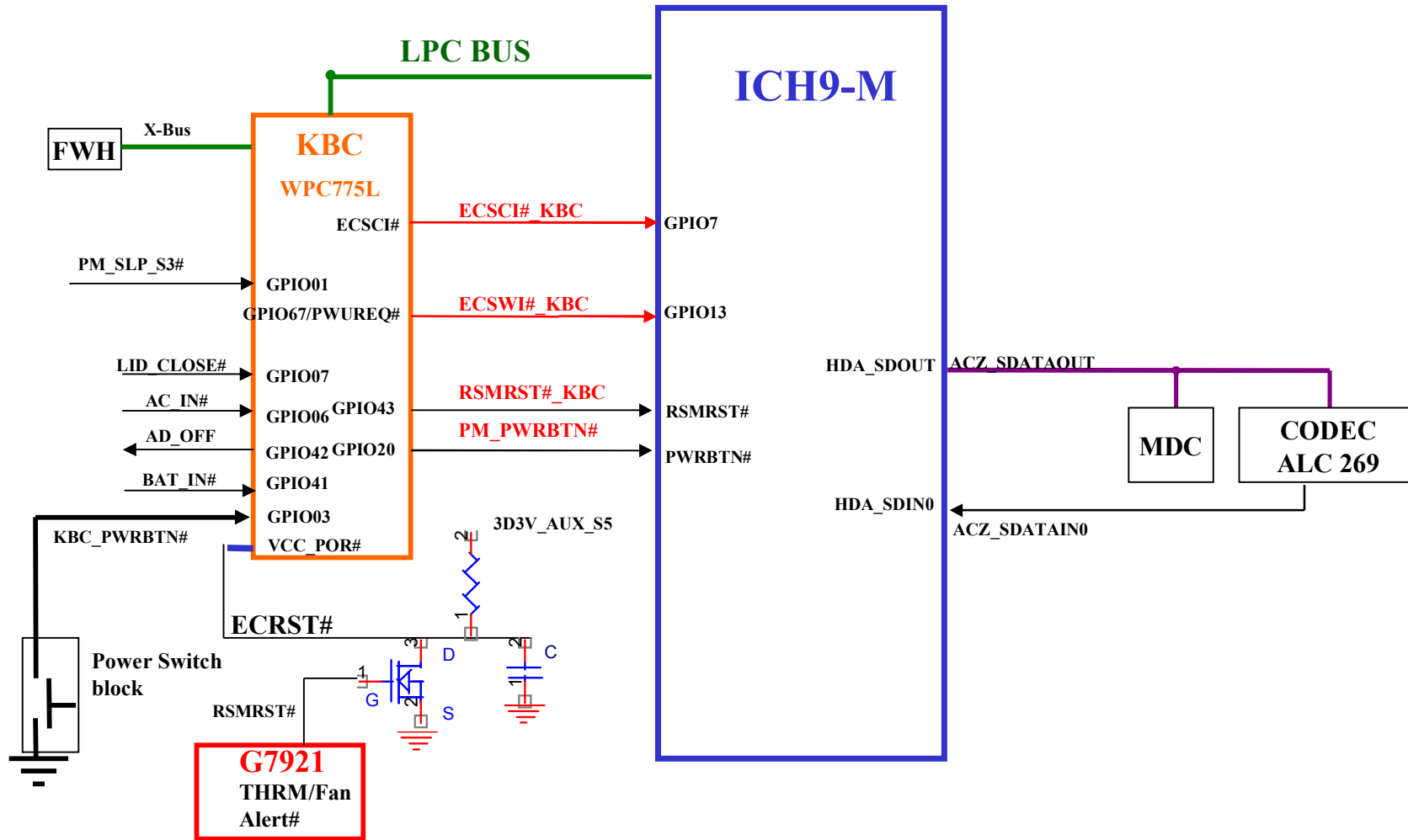

From S3 state wakeup event: (1) Power Button; (2) WOL (AC Only); (3) Embedded Modem (AC Only);(4) RTC; (5) Lid; (6) Battery Critical

P08B1 Audio Block Diagram

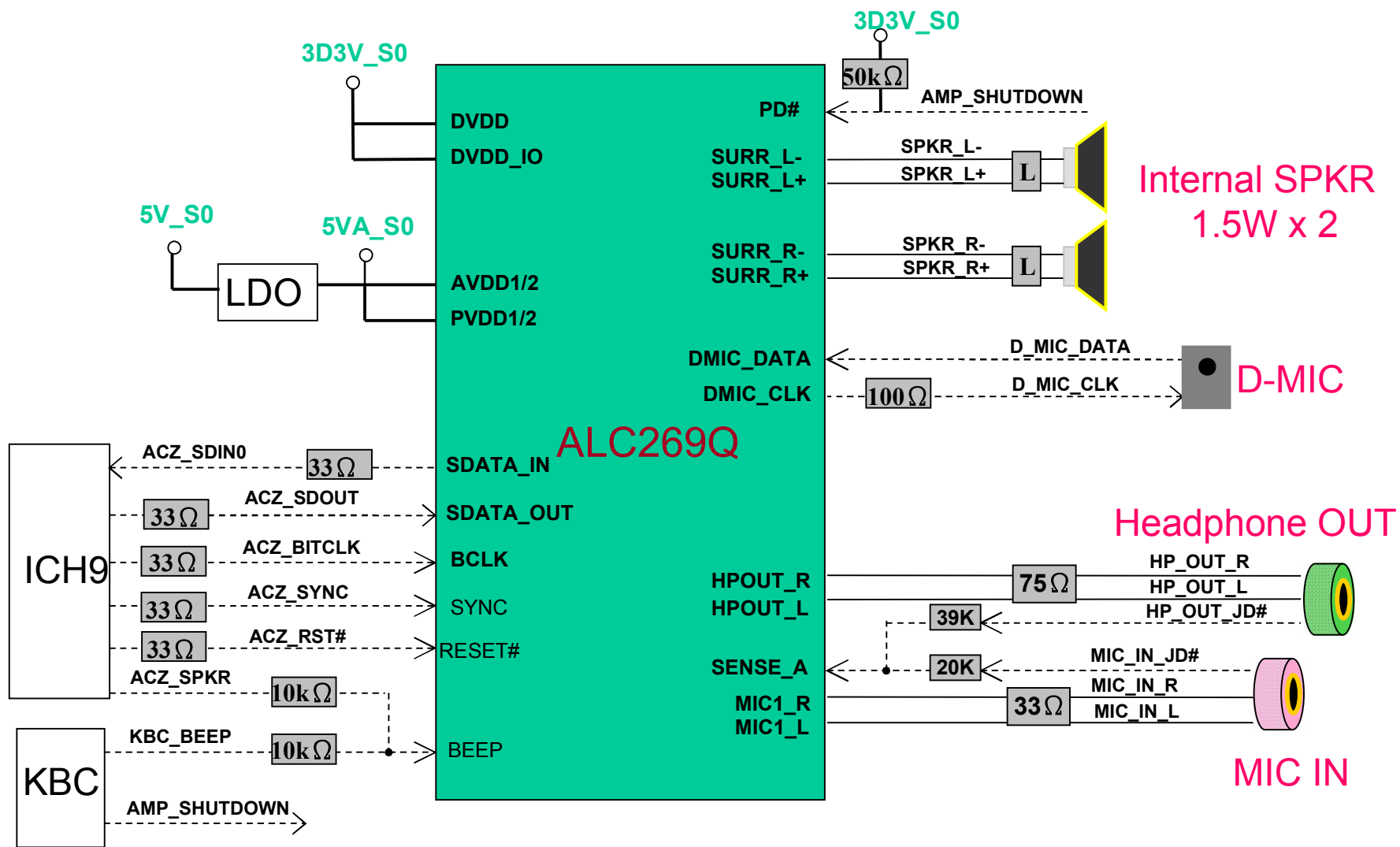

P08B1 Video Block Diagram

P08B1 SMB Interface - 1

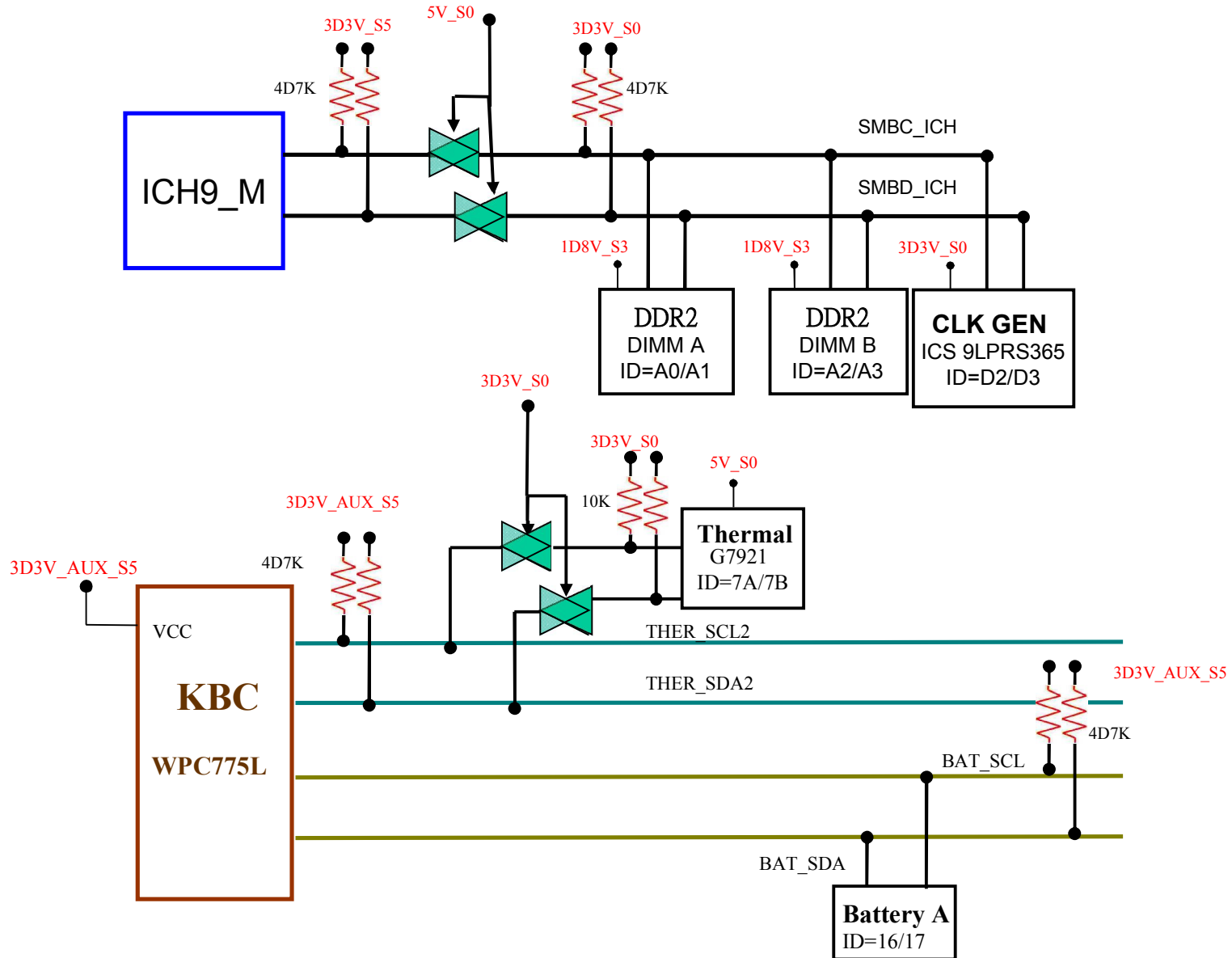

P08B1 SMB Interface - 2

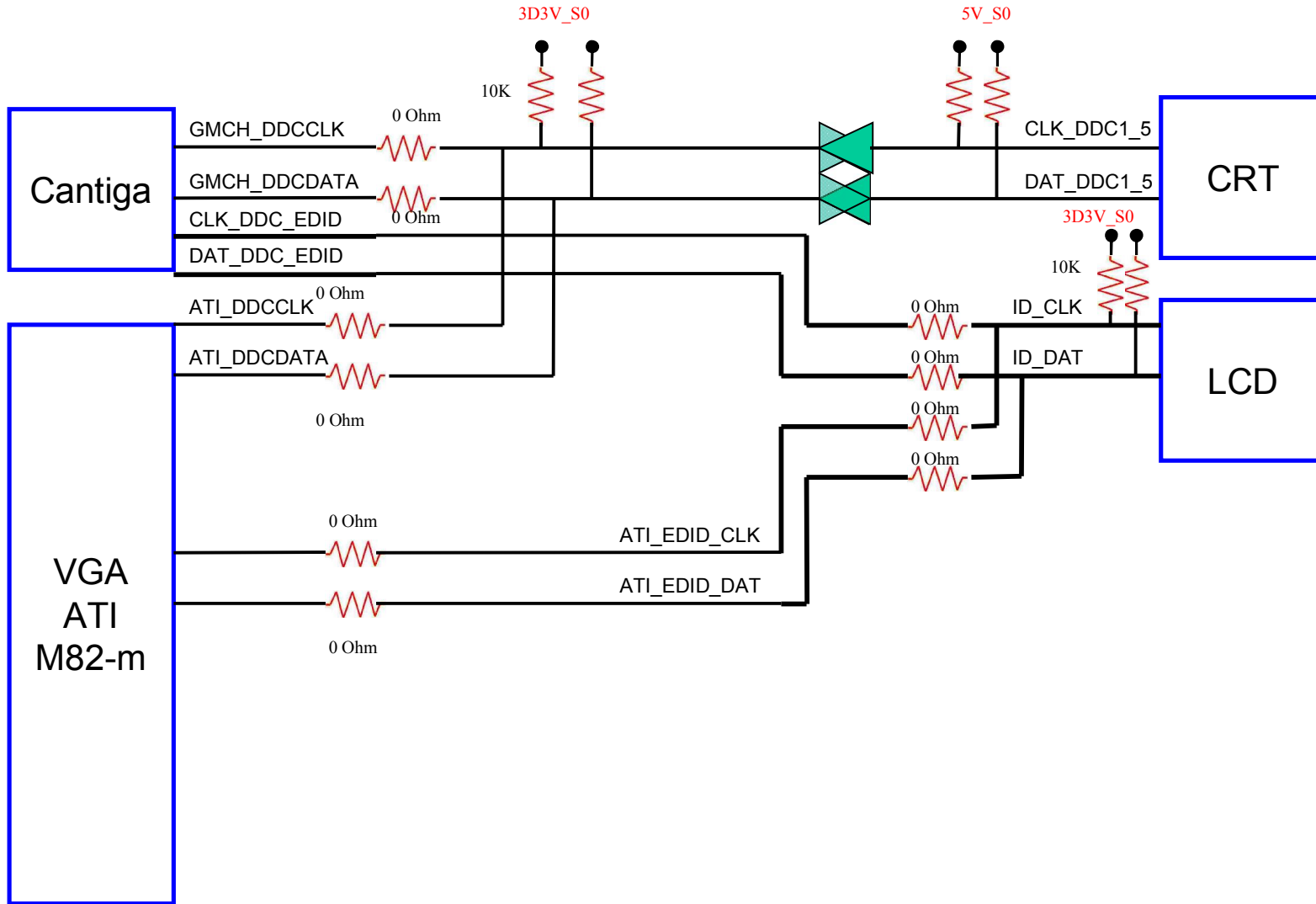

P08B1 Thermal Block Diagram

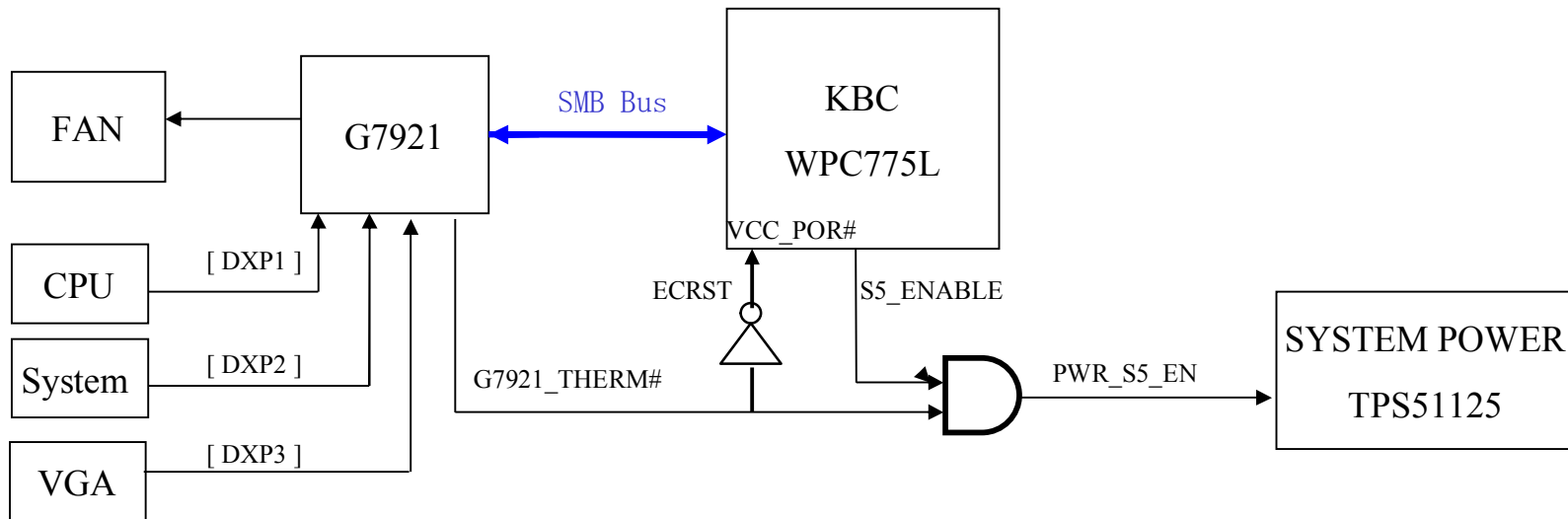

Thermal protection

- Fan on
- Down CPU speed
- S/W shutdown
- H/W shutdown

T=100

Layout Placement Top Side

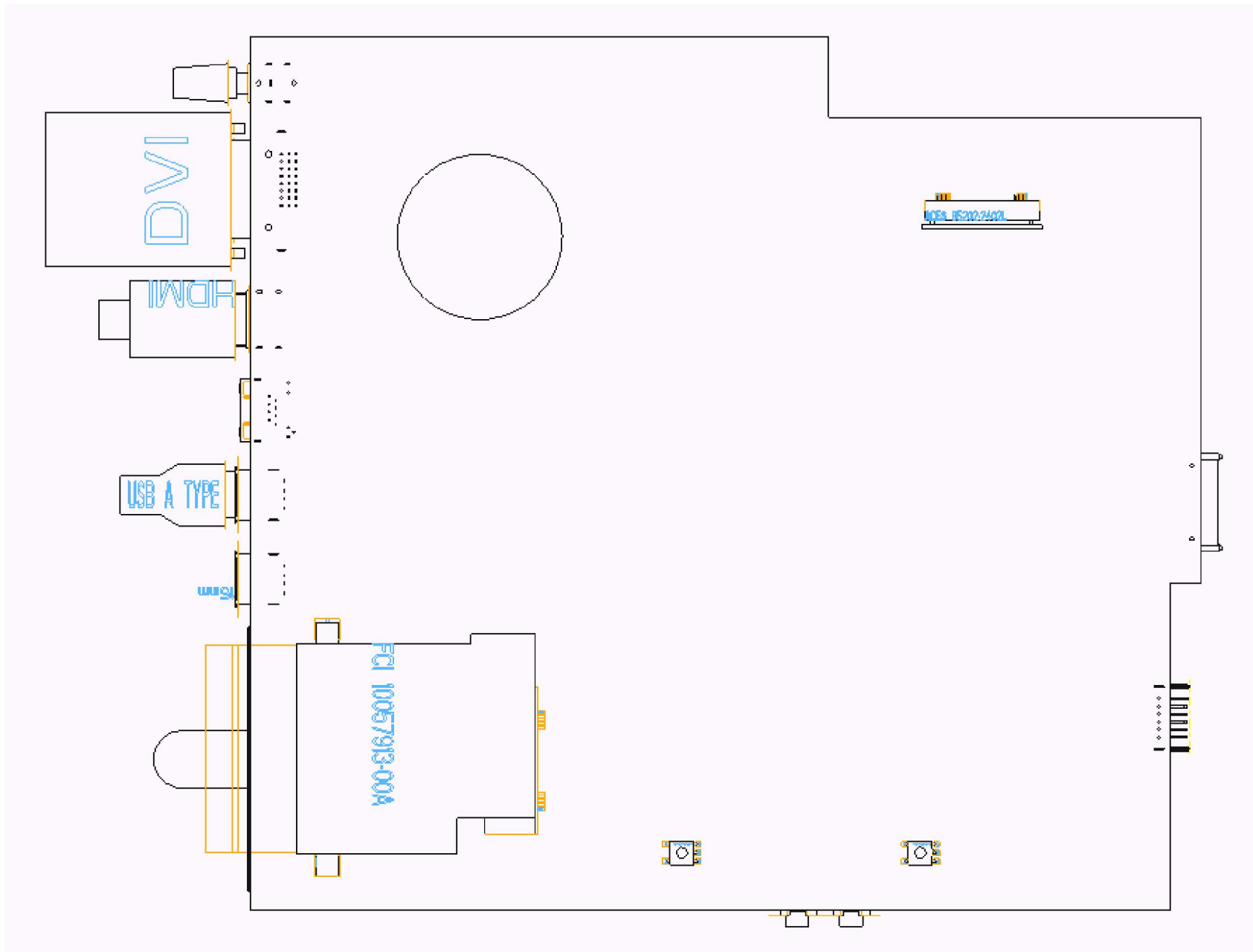

Layout Placement Bottom Side

