

SAMSUNG PROPRIETARY

THIS DOCUMENT CONTAINS CONFIDENTIAL PROPRIETARY INFORMATION THAT IS SAMSUNG ELECTRONICS CO.'S PROPERTY. DO NOT DISCLOSE TO OR DUPLICATE FOR OTHERS EXCEPT AS AUTHORIZED BY SAMSUNG.

TORINO 2

PCB Thickness:1mm

CPU :INTEL MEROM
Chip Set :INTEL 965GM & ICH8-M
Remarks :w/o INTEL AMT
2 SODIMMs

Model Name : TORINO 2
PBA Name : MAIN
PCB Code : BA41-00727A / 728A
Dev. Step : MP
Revision : 1.1
T.R. Date : 2007.04.10

DRAW	CHECK	APPROVAL
-	-	-

Table of Contents

Page. 1	---	COVER	
Page. 2	---	OPERATION BLOCK DIAGRAM] DIAGRAM
Page. 3	---	POWER DIAGRAM	
Page. 4	---	POWER SEQUENCE	
Page. 5	---	POWER RAIL	
Page. 6	---	CLOCK DISTRIBUTION	
Page. 7	---	BOARD INFORMATION	
Page. 8	---	CLOCK GENERATOR (CK-505)	
Page. 9~10	---	MEROM	
Page. 11	---	THERMAL MONITOR	
Page. 12~16	---	CRESTLINE (965GM)	
Page. 17	---	DDR2 SODIMM (TOP)	
Page. 18	---	DDR2 SODIMM (BOTTOM)	
Page. 19	---	DDR2 TERMINATION	
Page. 20~23	---	DISCRETE GFX (NB8M-SE & GDDR3)	
Page. 24~27	---	ICH8-M	
Page. 28	---	LCD (LVDS) CONN.	
Page. 29	---	CRT CONN.	
Page. 30	---	HDD & ODD CONNECTOR	
Page. 31	---	MICOM	
Page. 32	---	LAN CONTROLLER (10/100M)	
Page. 33	---	ROBSON	
Page. 34	---	USB PORT, MDC CONN. & BLUETOOTH	
Page. 35	---	MINI CARD SOCKET (WLAN/HSDPA/WIBRO)	
Page. 36	---	CARDBUS CONTROLLER(1) & 4IN1	
Page. 37	---	CARDBUS CONTROLLER(2) & 1394(4P)	
Page. 38	---	PCMCIA SOCKET	
Page. 39	---	AUDIO CODEC	
Page. 40	---	AUDIO AMP	
Page. 41	---	AUDIO JACK	
Page. 42	---	CHARGER	
Page. 43	---	P3.3V_AUX & P5V_AUX	
Page. 44	---	DDR2 POWER	
Page. 45	---	CPU VRM POWER	
Page. 46	---	P1.25V & P1.05V POWER	
Page. 47	---	GFX CORE & P1.5V POWER	
Page. 48	---	SWITCHED POWER	
Page. 49	---	POWER S/W, DMB, DEBUG & KEYBOARD CONN.	
Page. 50	---	LEDS & TOUCHPAD	
Page. 51	---	MOUNT HOLE	
Page. 52	---	TEST POINTS	
Page. 53	---	REVISION HISTORY	

DRAW	ZHOU JUN	DATE	4/10/2007	TITLE	TORINO 2	SAMSUNG ELECTRONICS
CHECK	GUO LEI	DEV. STEP	MP		COVER	
APPROVAL	KEVIN LEE	REV	1.1		CONTENTS	PART NO. BA41-00727/8A
MODULE CODE		LAST ENT			March 28, 2007 3:33:29 PM	PAGE 1 OF 54

SAMSUNG PROPRIETARY
 THIS DOCUMENT CONTAINS CONFIDENTIAL
 PROPRIETARY INFORMATION THAT IS
 SAMSUNG ELECTRONICS CO.'S PROPERTY.
 DO NOT DISCLOSE TO OR DUPLICATE FOR OTHERS
 EXCEPT AS AUTHORIZED BY SAMSUNG.

OPERATION BLOCK DIAGRAM

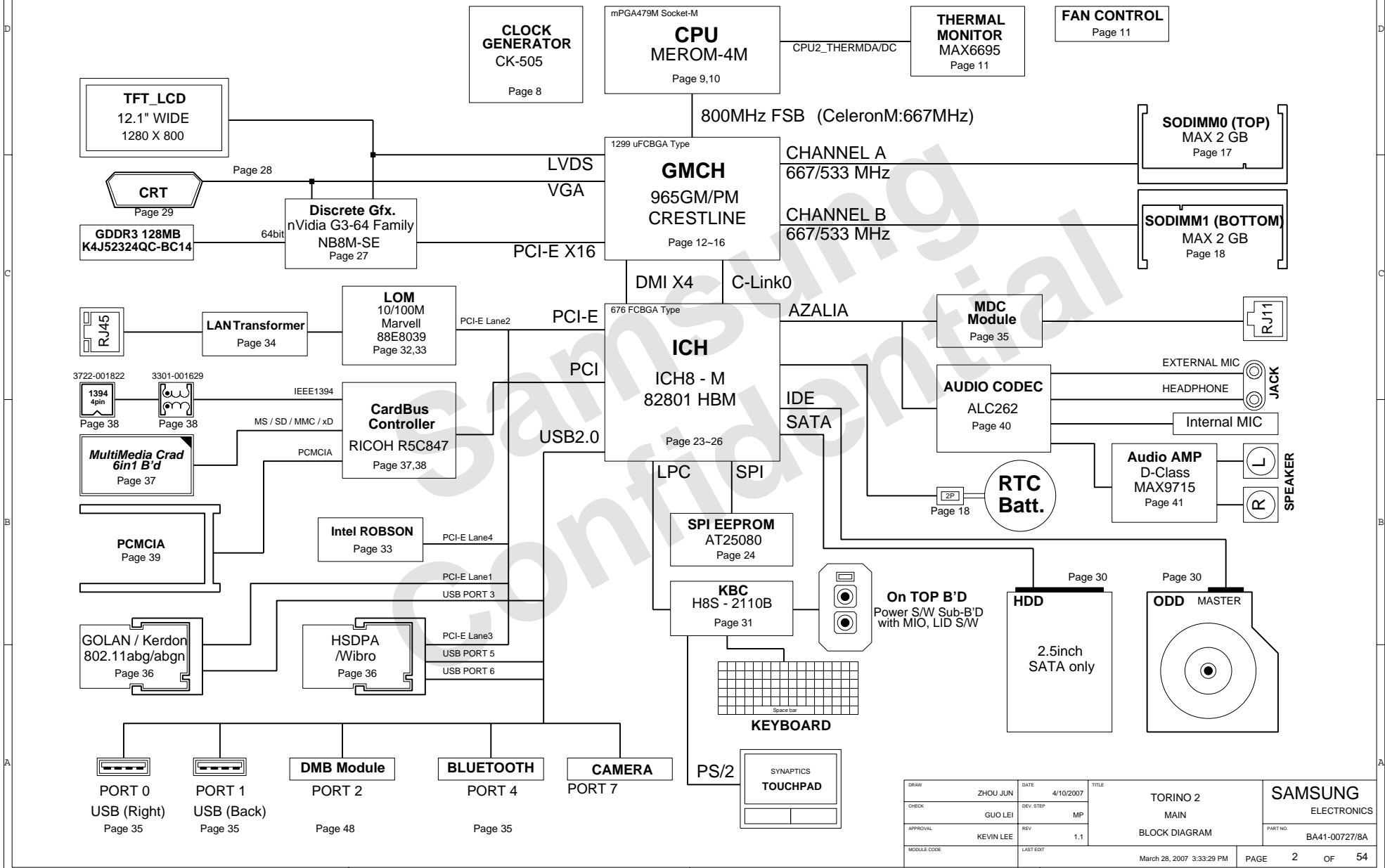

DRAW	ZHOU JUN	DATE	4/10/2007	TITLE	TORINO 2	SAMSUNG ELECTRONICS
CHECK	GUO LEI	DEV. STEP	MP		MAIN	
APPROVAL	KEVIN LEE	REV	1.1		BLOCK DIAGRAM	PART NO. BA41-00727/8A
MODULE CODE		LAST ENT			March 28, 2007 3:33:29 PM	PAGE 2 OF 54

SAMSUNG PROPRIETARY
 THIS DOCUMENT CONTAINS CONFIDENTIAL
 PROPRIETARY INFORMATION THAT IS
 SAMSUNG ELECTRONICS CO.'S PROPERTY.
 DO NOT DISCLOSE TO OR DUPLICATE FOR OTHERS
 EXCEPT AS AUTHORIZED BY SAMSUNG.

POWER DIAGRAM

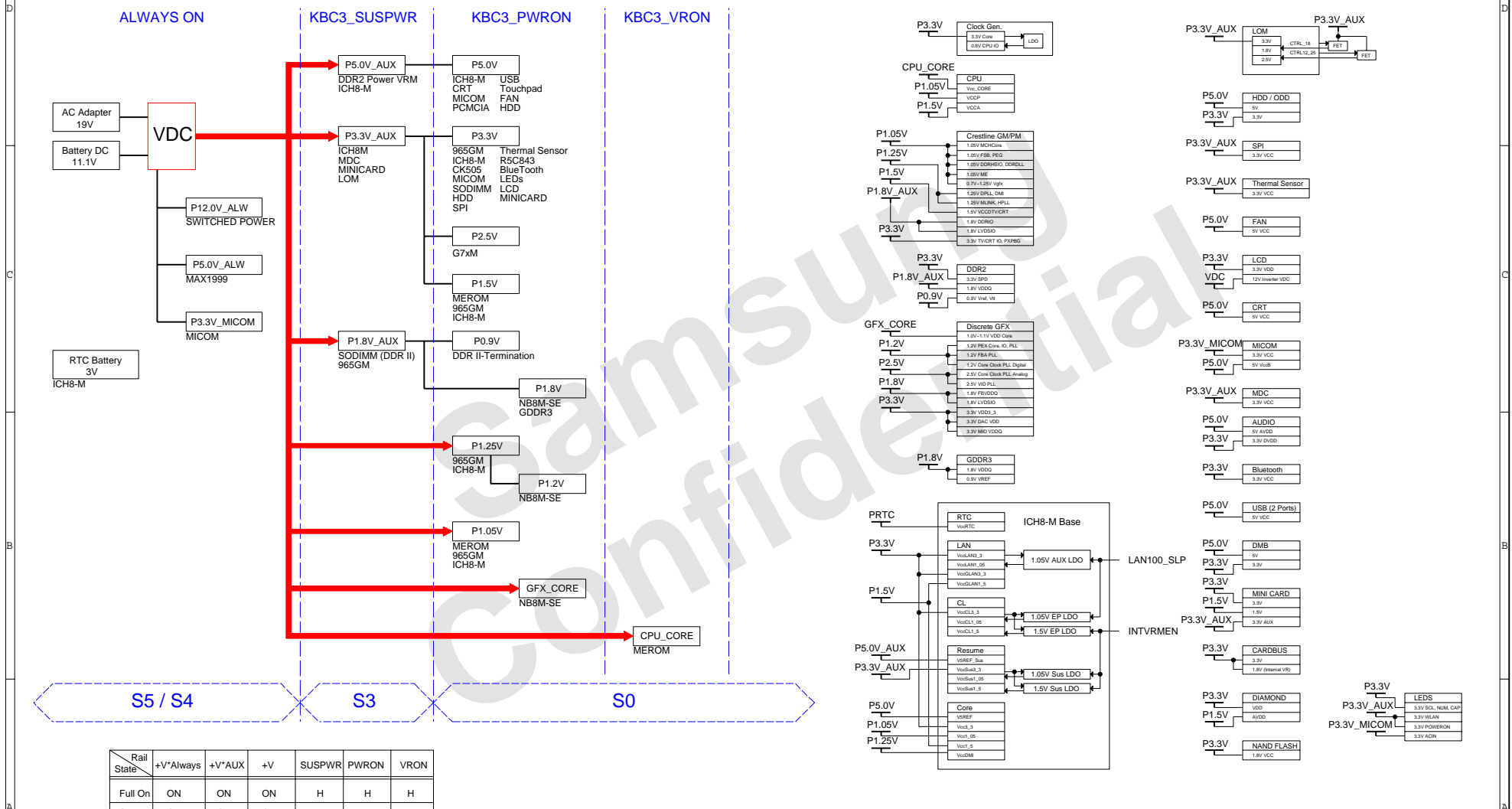

DRAW	ZHOU JUN	DATE	4/10/2007	TITLE	TORINO 2 MAIN POWER DIAGRAM	SAMSUNG ELECTRONICS PART NO. BA41-00727/8A
CHECK	GUO LEI	DEV. STEP	MP			
APPROVAL	KEVIN LEE	REV	1.1			
MODULE CODE		LAST ENT				

March 28, 2007 3:33:29 PM PAGE 3 OF 54

POWER SEQUENCE Rev. 0.1

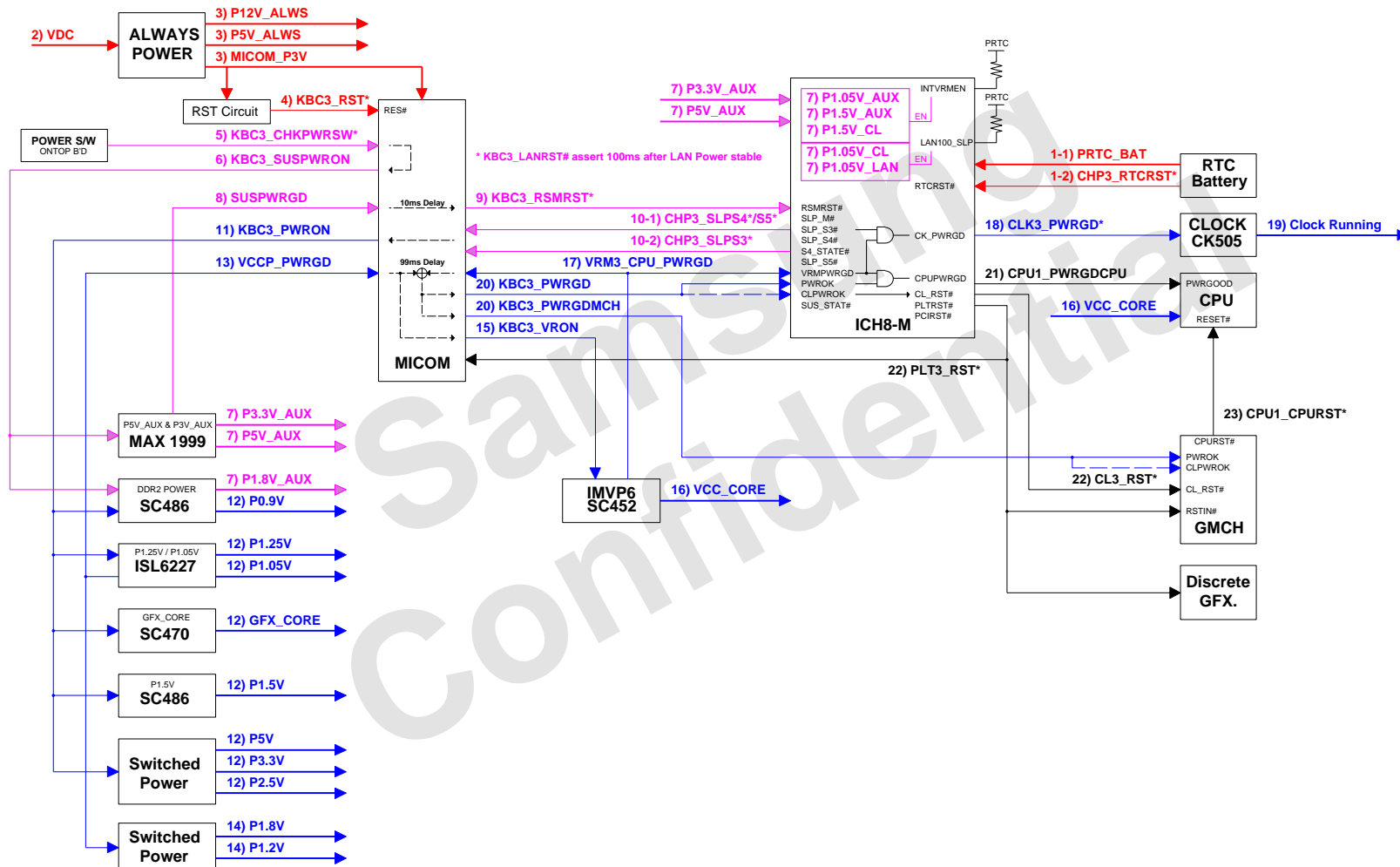

DRAW	ZHOU JUN	DATE	4/10/2007	TITLE	TORINO 2 MAIN POWER SEQUENCE	SAMSUNG ELECTRONICS
CHECK	GUO LEI	DEV. STEP	MP		PART NO. BA41-00727/8A	
APPROVAL	KEVIN LEE	REV	1.1			
MODULE CODE		LAST EDIT	March 28, 2007 3:33:29 PM	PAGE	4	OF 54

SAMSUNG PROPRIETARY

THIS DOCUMENT CONTAINS CONFIDENTIAL PROPRIETARY INFORMATION THAT IS SAMSUNG ELECTRONICS CO.'S PROPERTY. DO NOT DISCLOSE TO OR DUPLICATE FOR OTHERS EXCEPT AS AUTHORIZED BY SAMSUNG.

Timing Diagram, no ME

Rev. 0.2 Phil 2006-9-21

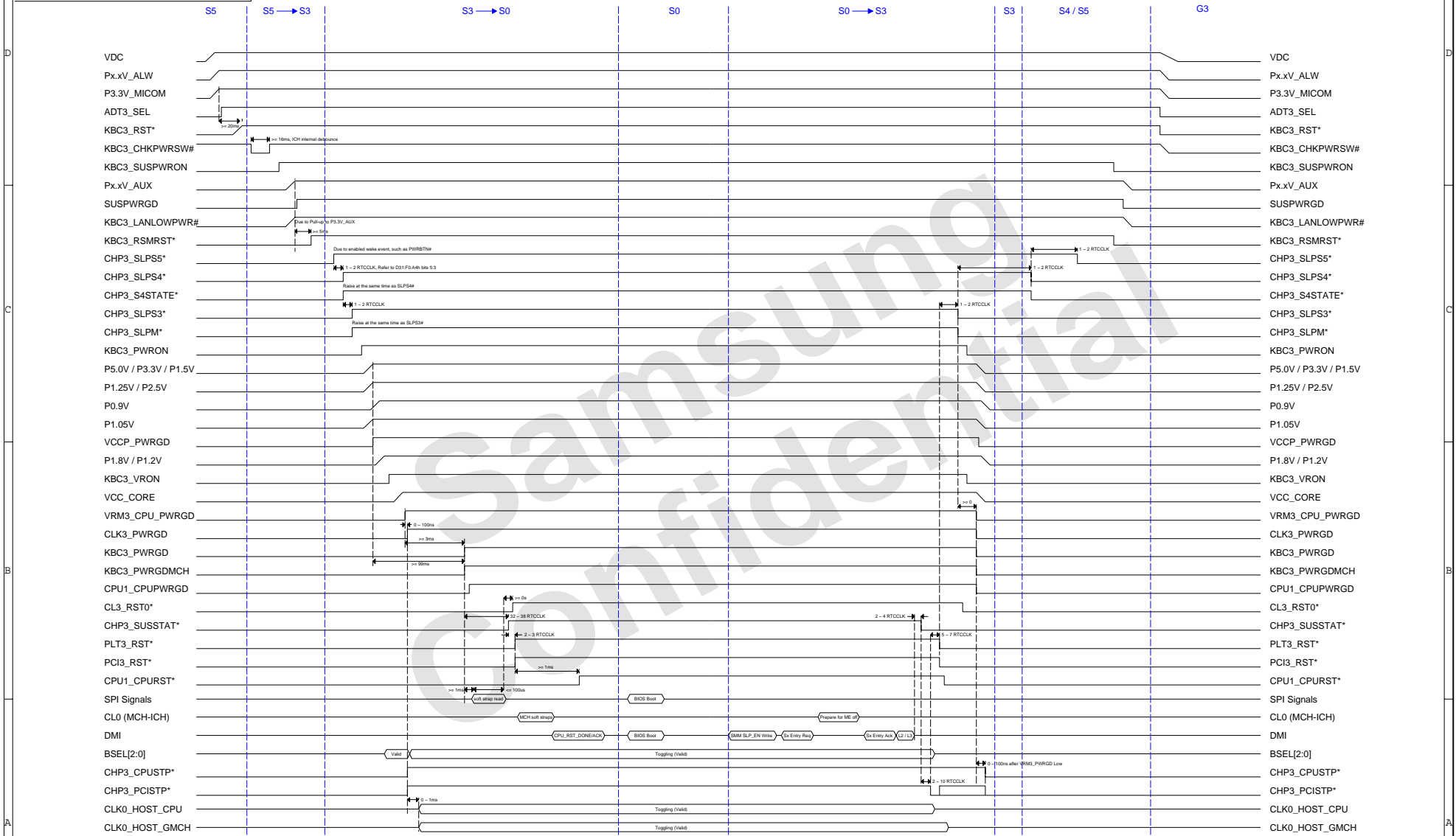

DRAW	ZHOU JUN	DATE	4/10/2007	TITLE	TORINO 2	SAMSUNG ELECTRONICS PART NO. BA41-00727/8A
CHECK	GUO LEI	DEV. STEP	MP		MAIN	
APPROVAL	KEVIN LEE	REV	1.1		TIMING DIAGRAM	
MODULE CODE		LAST ENT				
				March 28, 2007 3:33:29 PM	PAGE	5 OF 54

SAMSUNG PROPRIETARY
 THIS DOCUMENT CONTAINS CONFIDENTIAL
 PROPRIETARY INFORMATION THAT IS
 SAMSUNG ELECTRONICS CO.'S PROPERTY.
 DO NOT DISCLOSE TO OR DUPLICATE FOR OTHERS
 EXCEPT AS AUTHORIZED BY SAMSUNG.

CLOCK DISTRIBUTION Rev. 0.1

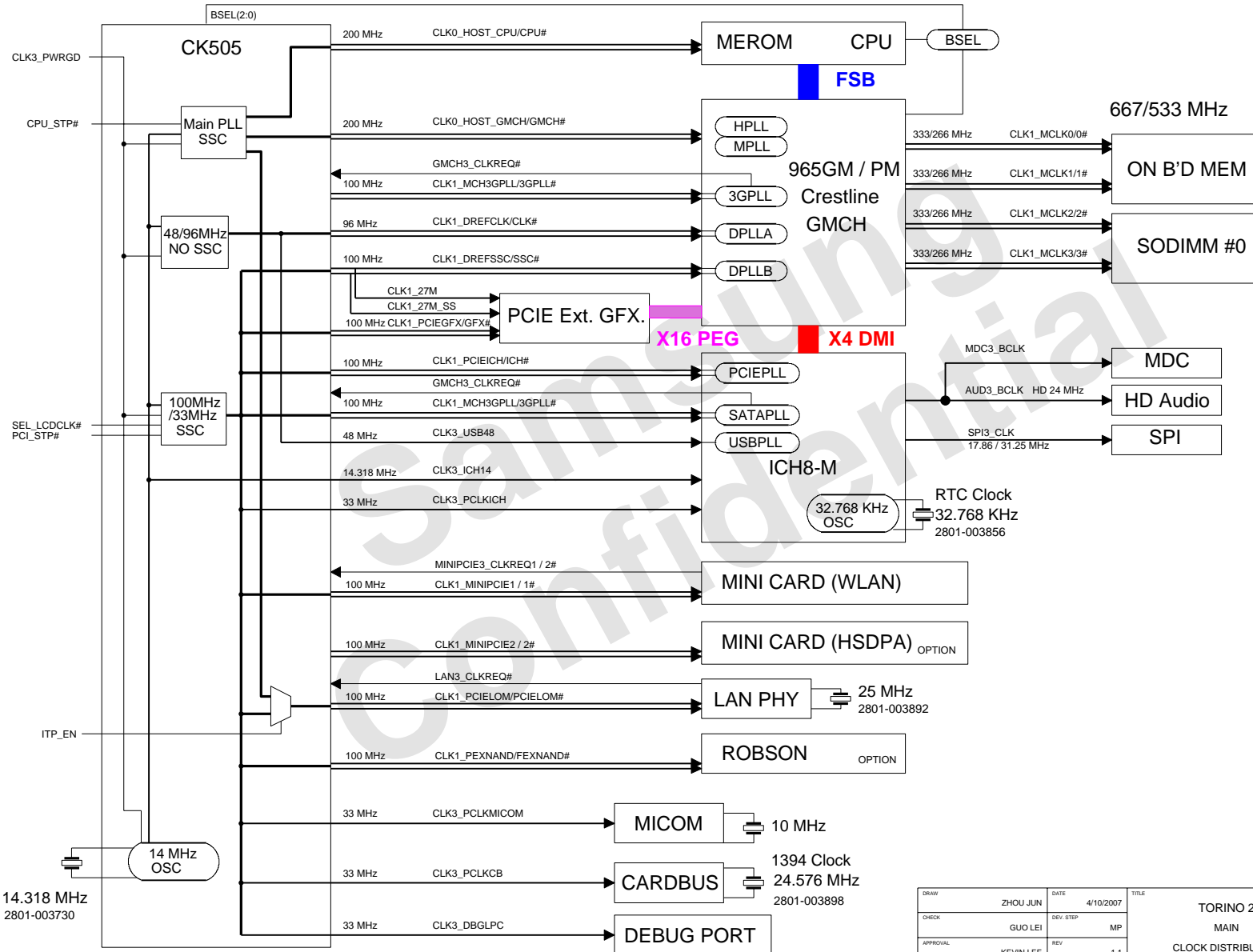

DRAW	ZHOU JUN	DATE	4/10/2007	TITLE	TORINO 2	SAMSUNG ELECTRONICS
CHECK	GUO LEI	DEV. STEP	MP	MAIN		
APPROVAL	KEVIN LEE	REV	1.1	CLOCK DISTRIBUTION	PART NO.	BA41-00727/8A
MODULE CODE		LAST EDIT		March 28, 2007 3:33:29 PM	PAGE	6 OF 54

SAMSUNG PROPRIETARY
 THIS DOCUMENT CONTAINS CONFIDENTIAL
 PROPRIETARY INFORMATION THAT IS
 SAMSUNG ELECTRONICS CO'S PROPERTY.
 DO NOT DISCLOSE TO OR DUPLICATE FOR OTHERS
 EXCEPT AS AUTHORIZED BY SAMSUNG.

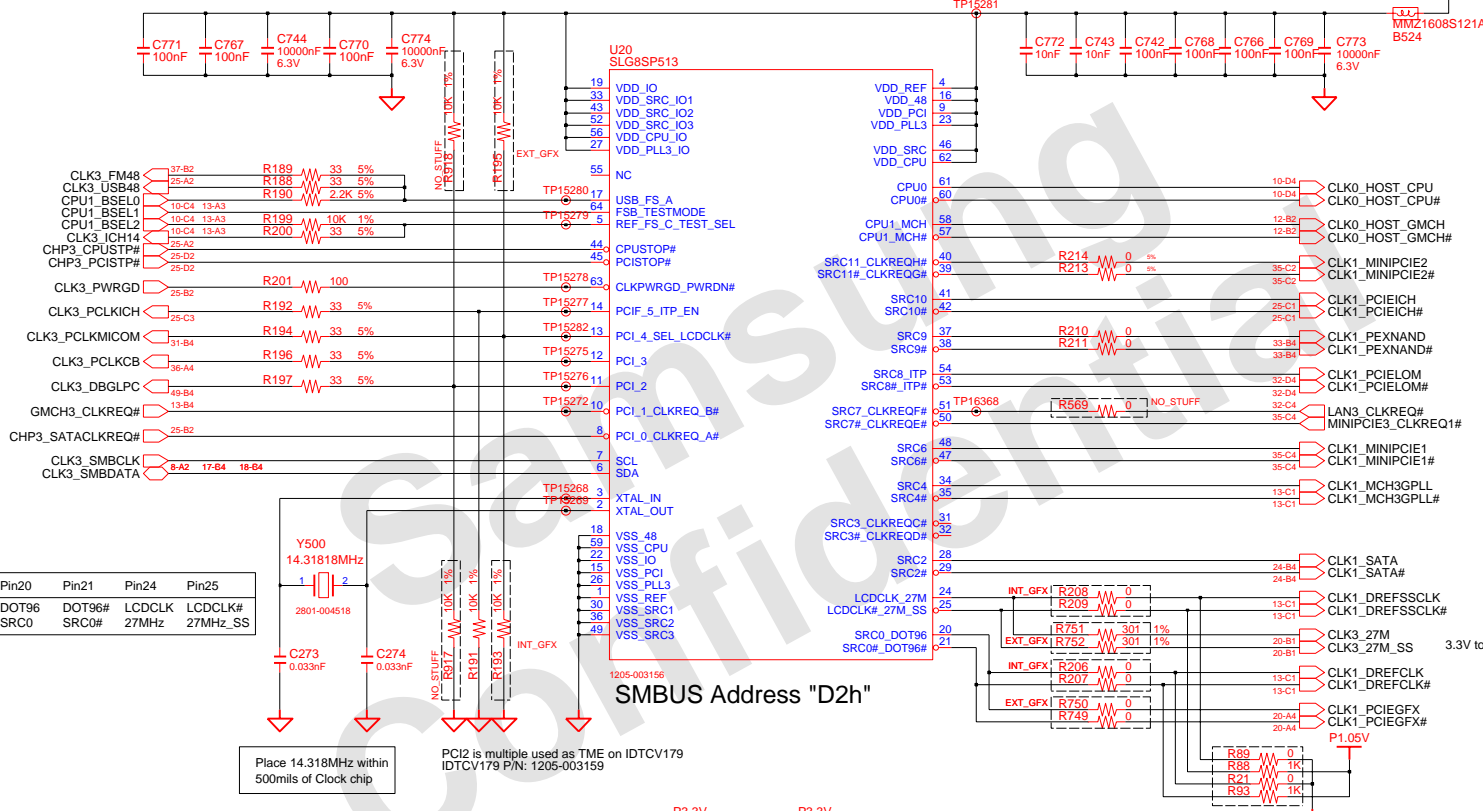

SEL_LCDCLK#	Pin20	Pin21	Pin24	Pin25
0	DOT96	DOT96#	LCDCLK	LCDCLK#
1	SRC0	SRC0#	27MHz	27MHz_SS

Place 14.318MHz within 500mils of Clock chip

PCI2 is multiple used as TME on IDTCV179 IDTCV179 P/N: 1205-003159

SMBUS Address "D2h"

3.3V to 1.2V Translation for G72M

CPU	FSA	FSB	FSC	HOST CLK
	BSEL0	BSEL1	BSEL2	
0	0	0	0	266 MHz
0	0	0	1	333 MHz
0	1	0	0	200 MHz
0	1	1	1	400 MHz
1	1	0	0	133 MHz
1	1	0	1	100 MHz
1	1	1	0	166 MHz
1	1	1	1	RSVD

CLK REQ	Mapping	Device
A#	SRC_2	SATA
B#	SRC_4	GMCH
E#	SRC_6	MiniCard(WLAN)
F#	SRC_8	GbE LAN (100M: N/A)

DRAW	ZHOU JUN	DATE	4/10/2007	TITLE	TORINO 2	SAMSUNG ELECTRONICS
CHECK	GUO LEI	DEV_STEP	MP	MAIN		
APPROVAL	KEVIN LEE	REV	1,1	CLOCK GENERATOR		PART NO. BA41-00727/8A
MODULE CODE		LAST EDIT			March 28, 2007 3:33:29 PM	PAGE 8 OF 54

CPU SOCKET : MEROM

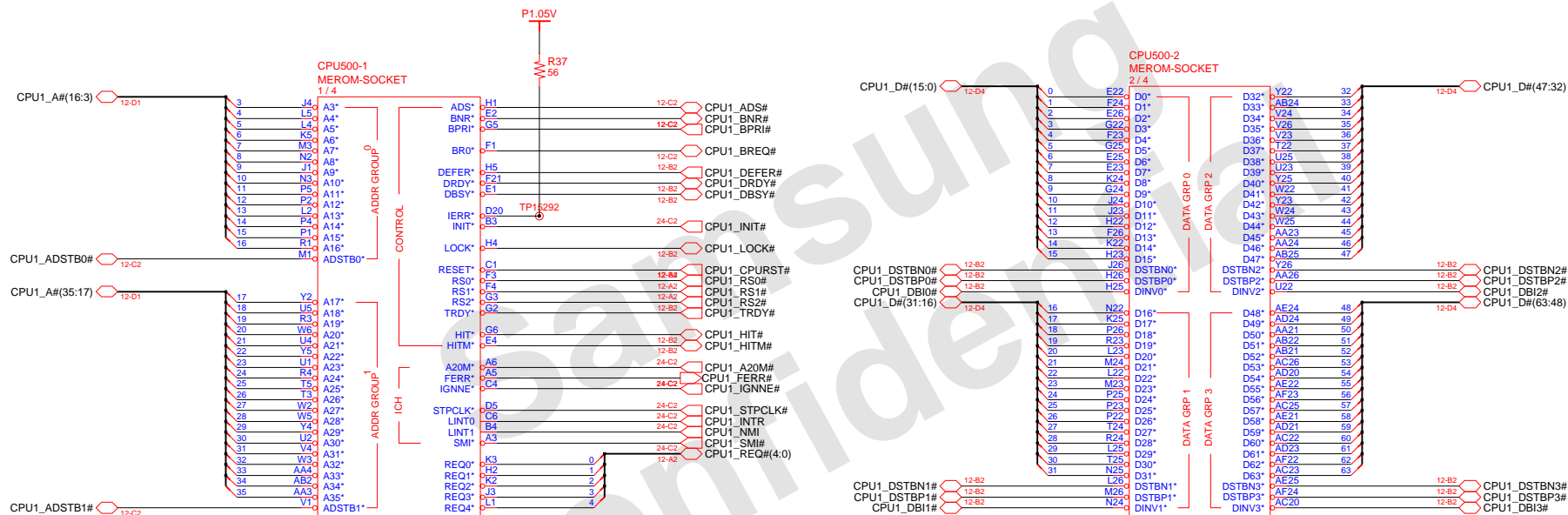

DRAW	ZHOU JUN	DATE	4/10/2007	TITLE	TORINO 2 MAIN MEROM(1)	SAMSUNG ELECTRONICS PART NO. BA41-00727/8A
CHECK	GUO LEI	DEV. STEP	MP			
APPROVAL	KEVIN LEE	REV	1.1			
MODULE CODE		LAST TEST				
March 28, 2007 3:33:29 PM						PAGE 9 OF 54

SAMSUNG PROPRIETARY
 THIS DOCUMENT CONTAINS CONFIDENTIAL
 PROPRIETARY INFORMATION THAT IS
 SAMSUNG ELECTRONICS CO'S PROPERTY.
 DO NOT DISCLOSE TO OR DUPLICATE FOR OTHERS
 EXCEPT AS AUTHORIZED BY SAMSUNG.

CPU SOCKET : MEROM

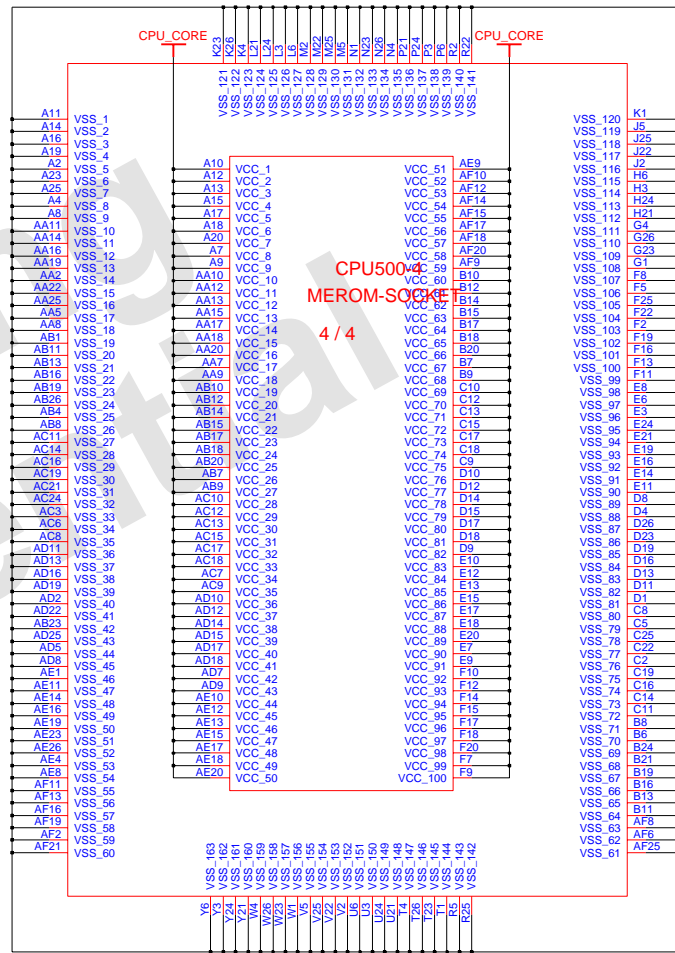
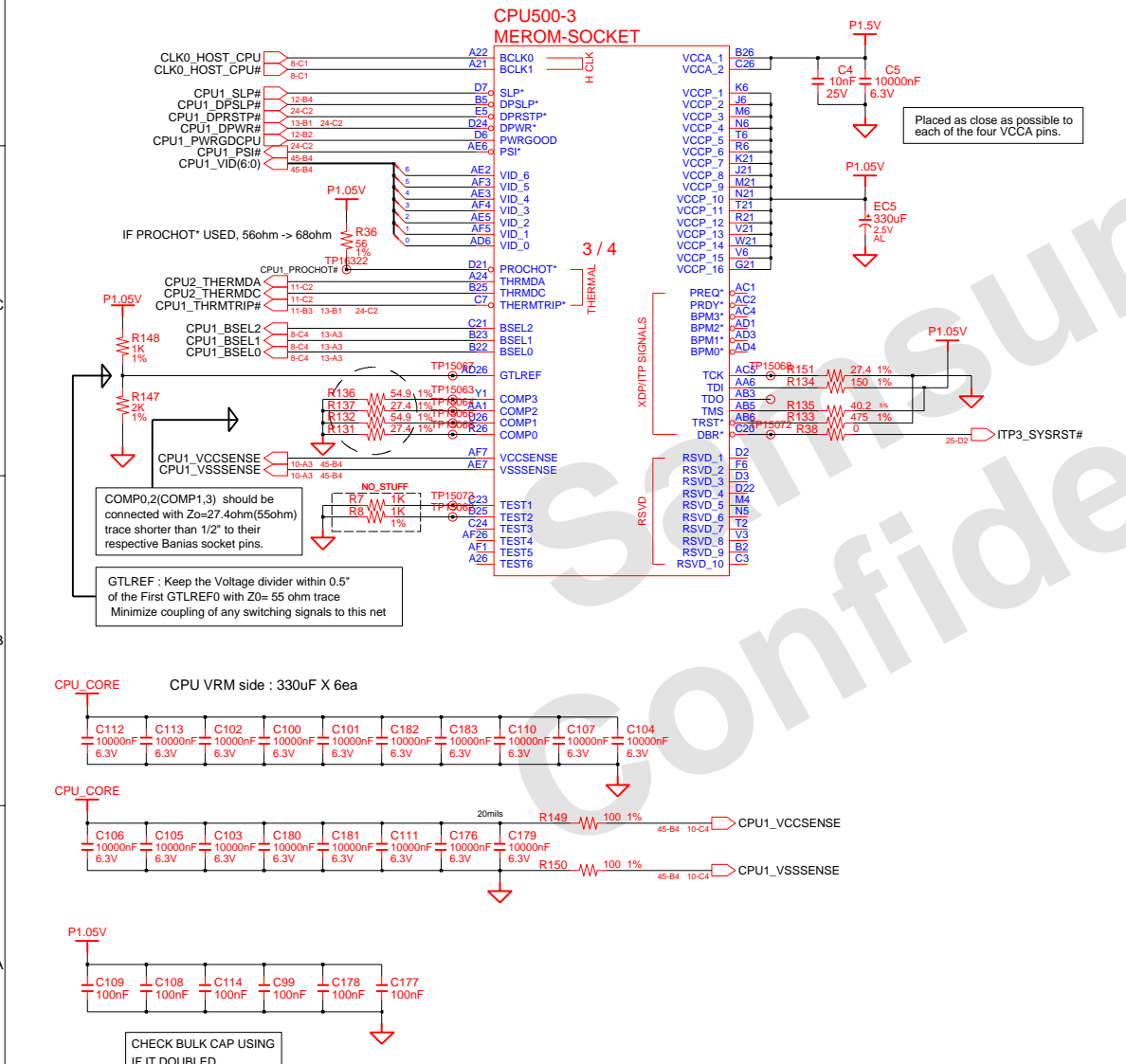

DRAW	ZHOU JUN	DATE	4/10/2007	TITLE	TORINO 2	SAMSUNG ELECTRONICS
CHECK	GUO LEI	DEV STEP	MP	MAIN	BA41-00727/8A	
APPROVAL	KEVIN LEE	REV	1.1	MEROM(2)	PAGE	10 OF 54
MODULE CODE		LAST ENT			March 28, 2007 3:33:29 PM	

SAMSUNG PROPRIETARY
 THIS DOCUMENT CONTAINS CONFIDENTIAL
 PROPRIETARY INFORMATION THAT IS
 SAMSUNG ELECTRONICS CO'S PROPERTY.
 DO NOT DISCLOSE TO OR DUPLICATE FOR OTHERS
 EXCEPT AS AUTHORIZED BY SAMSUNG.

Thermal Monitor

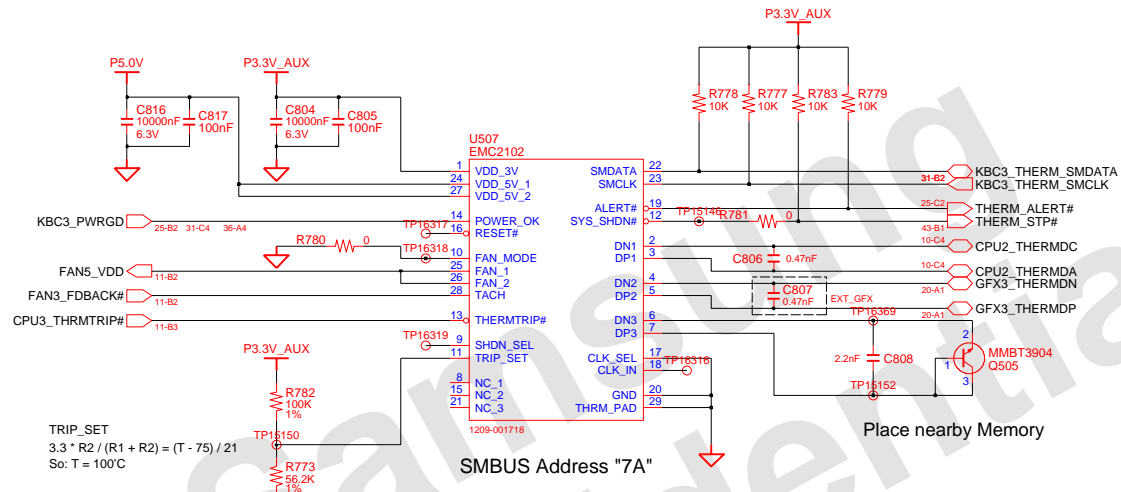

FAN Control

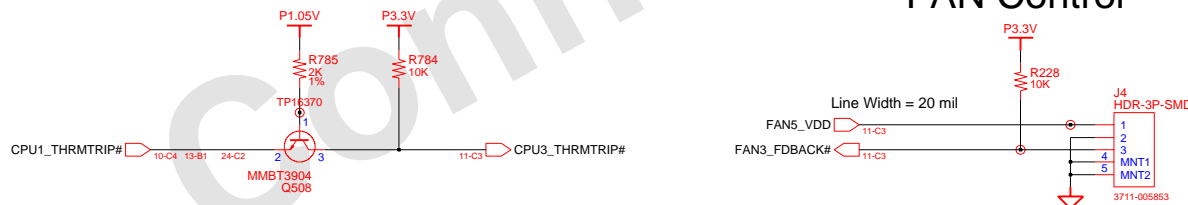

DRAW	ZHOU JUN	DATE	4/10/2007	TITLE	TORINO 2 MAIN	SAMSUNG ELECTRONICS
CHECK	GUO LEI	DEV_STEP	MP		THERMAL MONITOR	PART NO. BA41-00727/8A
APPROVAL	KEVIN LEE	REV	1,1			
MODULE CODE		LAST EDIT		March 28, 2007 3:33:29 PM	PAGE 11 OF 54	

SAMSUNG PROPRIETARY
 THIS DOCUMENT CONTAINS CONFIDENTIAL
 PROPRIETARY INFORMATION THAT IS
 SAMSUNG ELECTRONICS CO'S PROPERTY.
 DO NOT DISCLOSE TO OR DUPLICATE FOR OTHERS
 EXCEPT AS AUTHORIZED BY SAMSUNG.

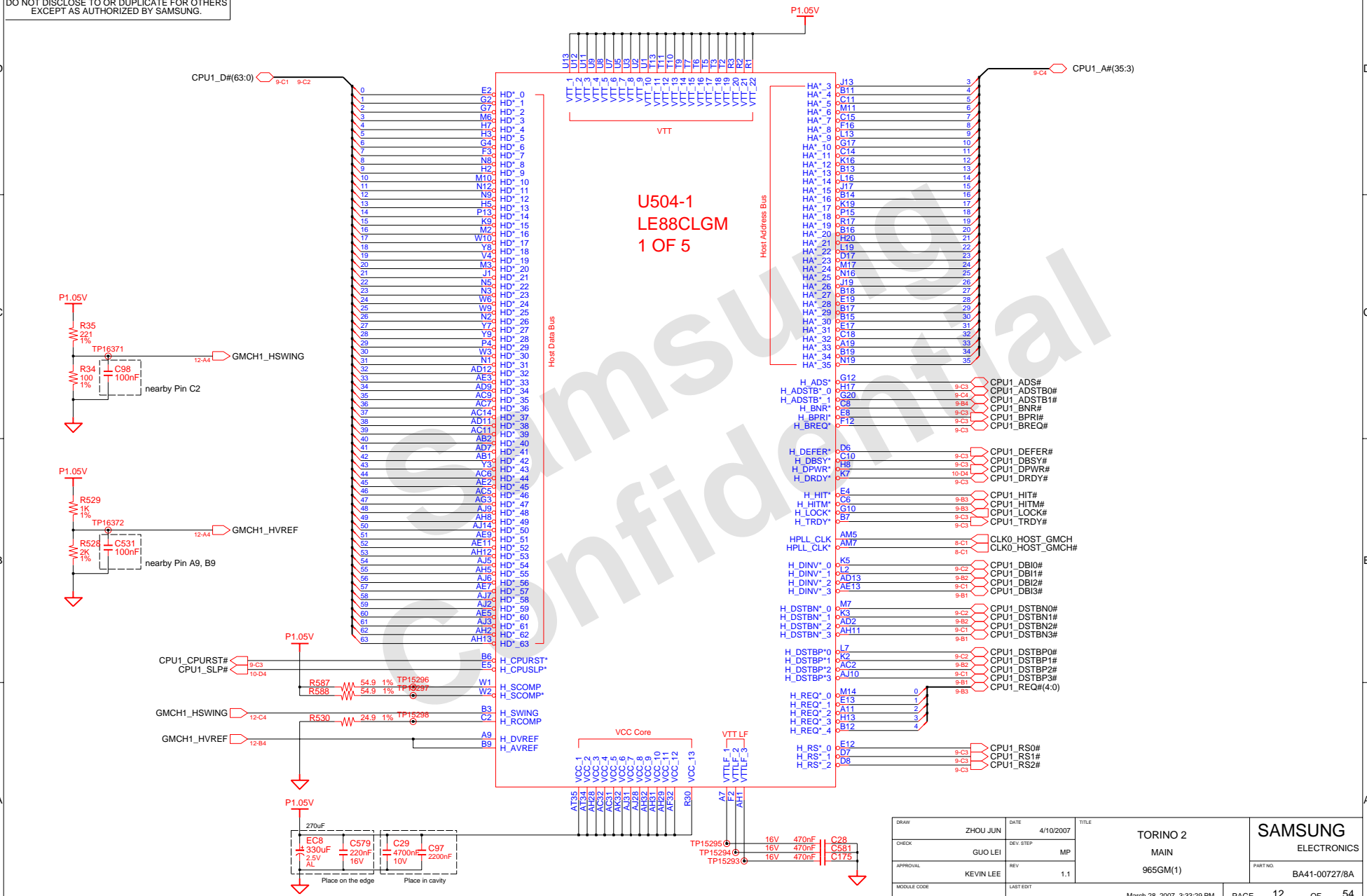

DRAW	ZHOU JUN	DATE	4/10/2007	TITLE	TORINO 2	SAMSUNG ELECTRONICS
CHECK	GUO LEI	DEV_STEP	MP		MAIN	
APPROVAL	KEVIN LEE	REV	1.1		965GM(1)	
MODULE CODE		LAST EDIT				PART NO. BA41-00727/8A
				March 28, 2007 3:33:29 PM	PAGE	12 OF 54

SAMSUNG PROPRIETARY
 THIS DOCUMENT CONTAINS CONFIDENTIAL
 PROPRIETARY INFORMATION THAT IS
 SAMSUNG ELECTRONICS CO.'S PROPERTY.
 DO NOT DISCLOSE TO OR DUPLICATE FOR OTHERS
 EXCEPT AS AUTHORIZED BY SAMSUNG.

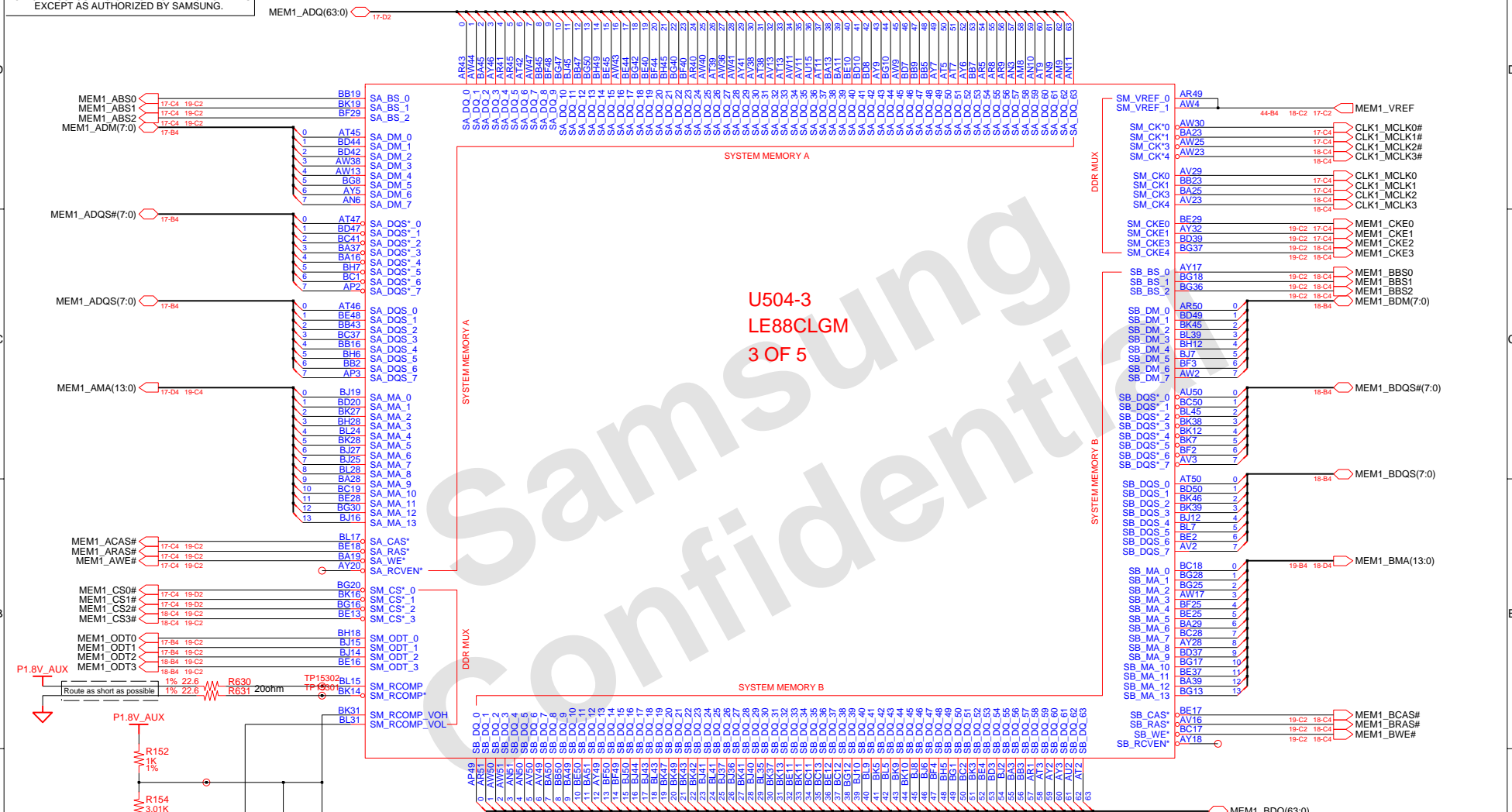

**U504-3
 LE88CLGM
 3 OF 5**

Dual Channel	Ch. A (So-DIMM A)	Ch. B (So-DIMM B)
SM_CK(2:0)	SA_CK(2:0)	N/A
SM_CK(2:0)*	SA_CK(2:0)*	N/A
SM_CK(5:3)	N/A	SB_CK(2:0)
SM_CK(5:3)*	N/A	SB_CK(2:0)*
SM_CS(1:0)*	SA_CS(1:0)*	N/A
SM_CKE(1:0)	SA_CKE(1:0)	N/A
SM_ODT(1:0)	SA_ODT(1:0)	N/A
SM_CS(3:2)	N/A	SB_CS(3:2)*
SM_SKE(3:2)	N/A	SB_CKE(3:2)
SM_ODT(3:2)	N/A	SB_ODT(3:2)

DRAW	ZHOU JUN	DATE	4/10/2007	TITLE	TORINO 2	SAMSUNG ELECTRONICS
CHECK	GUO LEI	DEV_STEP	MP		MAIN	
APPROVAL	KEVIN LEE	REV	1.1		965GM(3)	
MODULE CODE		LAST EDIT				PART NO. BA41-00727/8A
					March 28, 2007 3:33:29 PM	PAGE 14 OF 54

SAMSUNG PROPRIETARY
 THIS DOCUMENT CONTAINS CONFIDENTIAL
 PROPRIETARY INFORMATION THAT IS
 SAMSUNG ELECTRONICS CO.'S PROPERTY.
 DO NOT DISCLOSE TO OR DUPLICATE FOR OTHERS
 EXCEPT AS AUTHORIZED BY SAMSUNG.

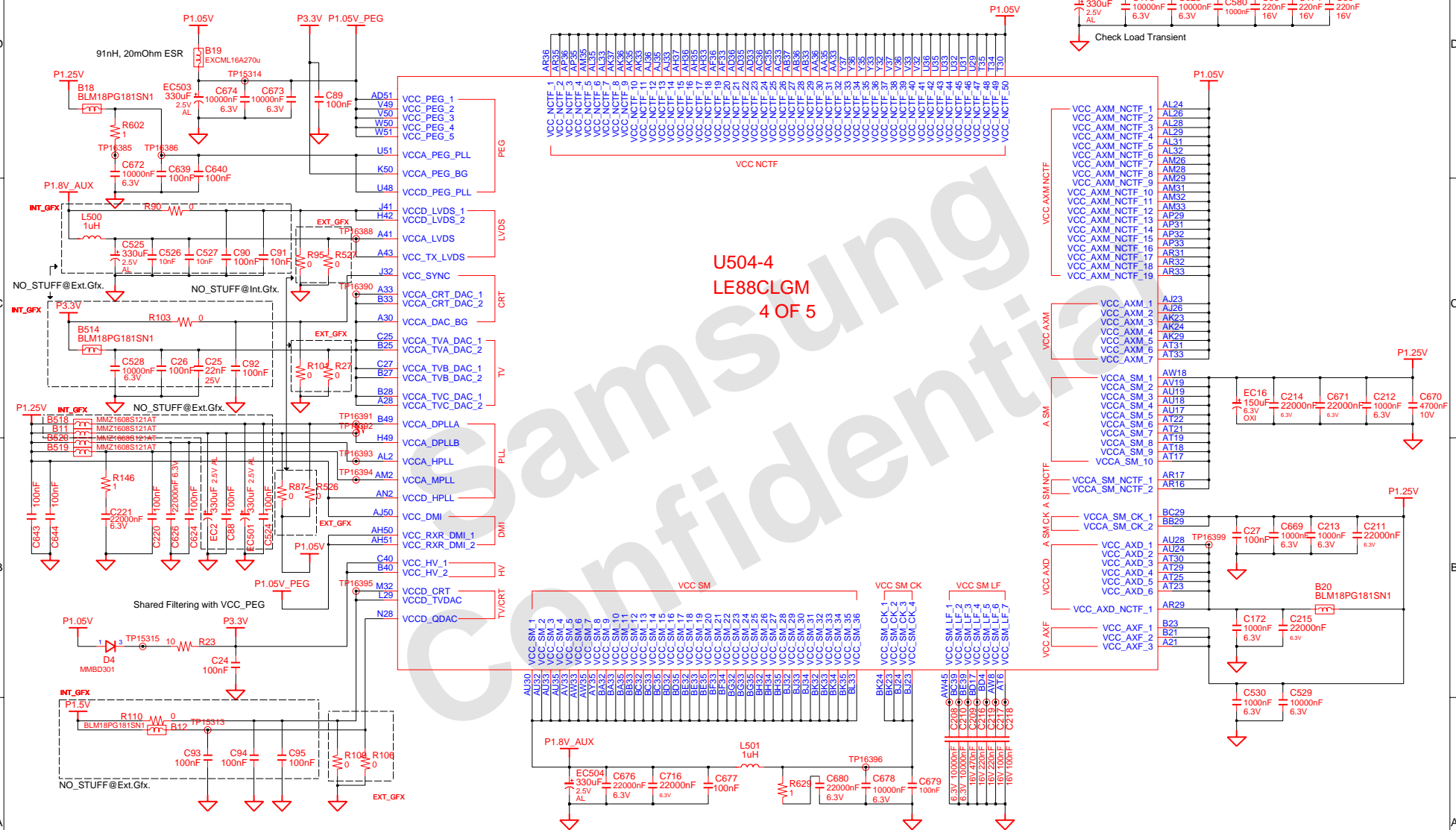

U504-4
 LE88CLGM
 4 OF 5

DRAW	ZHOU JUN	DATE	4/10/2007	TITLE	TORINO 2	SAMSUNG ELECTRONICS
CHECK	GUO LEI	DEV. STEP	MP		MAIN	
APPROVAL	KEVIN LEE	REV	1.1		965GM(4)	
MODULE CODE		LAST ENT				

Part No.	BA41-00727/8A
Page	15 of 54
Date	March 28, 2007 3:33:29 PM

SAMSUNG PROPRIETARY
 THIS DOCUMENT CONTAINS CONFIDENTIAL
 PROPRIETARY INFORMATION THAT IS
 SAMSUNG ELECTRONICS CO'S PROPERTY.
 DO NOT DISCLOSE TO OR DUPLICATE FOR OTHERS
 EXCEPT AS AUTHORIZED BY SAMSUNG.

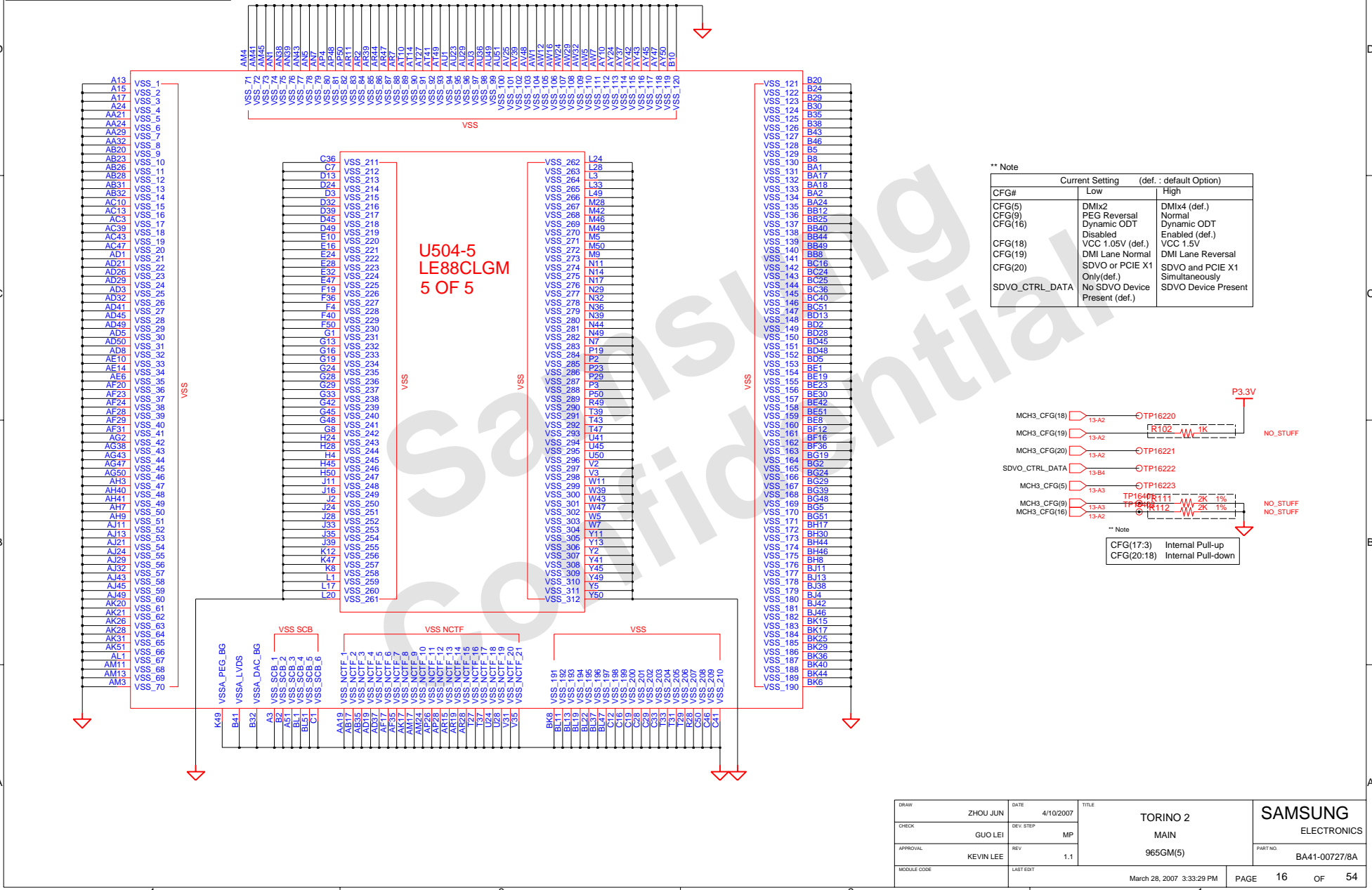

**** Note**

CFG#	Current Setting (def. : default Option)	
	Low	High
CFG(5)	DMix2	DMix4 (def.)
CFG(9)	PEG Reversal	Normal
CFG(16)	Dynamic ODT	Dynamic ODT
	Disabled	Enabled (def.)
CFG(18)	VCC 1.05V (def.)	VCC 1.5V
CFG(19)	DMI Lane Normal	DMI Lane Reversal
CFG(20)	SDVO or PCIe X1 Only(def.)	SDVO and PCIe X1 Simultaneously
SDVO_CTRL_DATA	No SDVO Device Present (def.)	SDVO Device Present

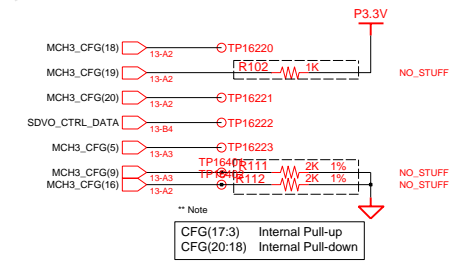

DRAW	ZHOU JUN	DATE	4/10/2007	TITLE	TORINO 2	SAMSUNG ELECTRONICS PART NO. BA41-00727/8A
CHECK	GUO LEI	DEV_STEP	MP		MAIN	
APPROVAL	KEVIN LEE	REV	1,1		965GM(5)	
MODULE CODE		LAST ENT				
				March 28, 2007 3:33:29 PM	PAGE	16 OF 54

SAMSUNG PROPRIETARY
 THIS DOCUMENT CONTAINS CONFIDENTIAL
 PROPRIETARY INFORMATION THAT IS
 SAMSUNG ELECTRONICS CO'S PROPERTY.
 DO NOT DISCLOSE TO OR DUPLICATE FOR OTHERS
 EXCEPT AS AUTHORIZED BY SAMSUNG.

SODIMM0 (TOP)

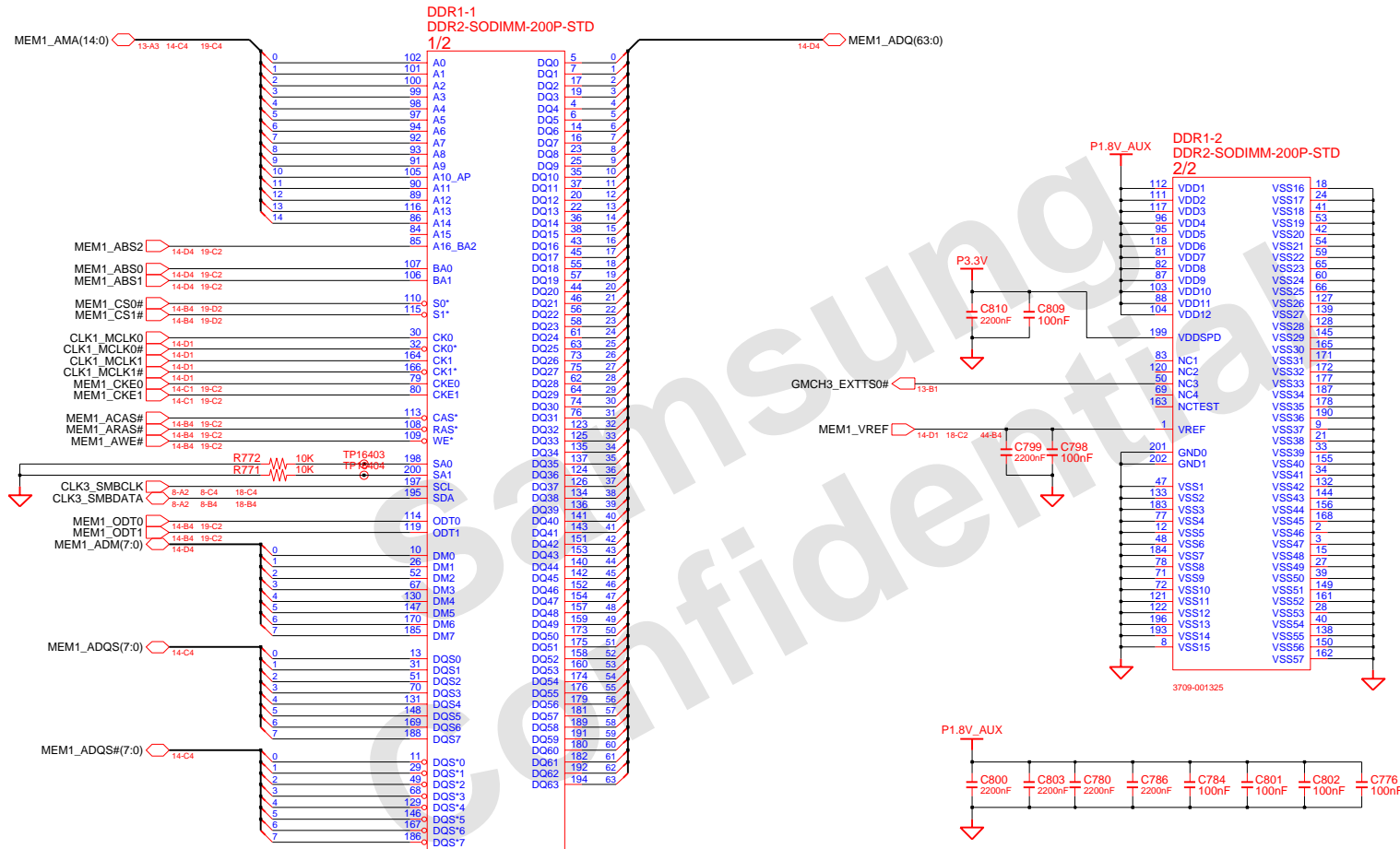

DRAW	ZHOU JUN	DATE	4/10/2007	TITLE	TORINO 2	SAMSUNG ELECTRONICS
CHECK	GUO LEI	DEV. STEP	MP		MAIN	
APPROVAL	KEVIN LEE	REV	1.1		DDR2 SODIMM (TOP)	PART NO. BA41-00727/8A
MODULE CODE		LAST EDIT		March 28, 2007 3:33:29 PM	PAGE	17 OF 54

SAMSUNG PROPRIETARY
 THIS DOCUMENT CONTAINS CONFIDENTIAL
 PROPRIETARY INFORMATION THAT IS
 SAMSUNG ELECTRONICS CO'S PROPERTY.
 DO NOT DISCLOSE TO OR DUPLICATE FOR OTHERS
 EXCEPT AS AUTHORIZED BY SAMSUNG.

SODIMM1 (BOTTOM)

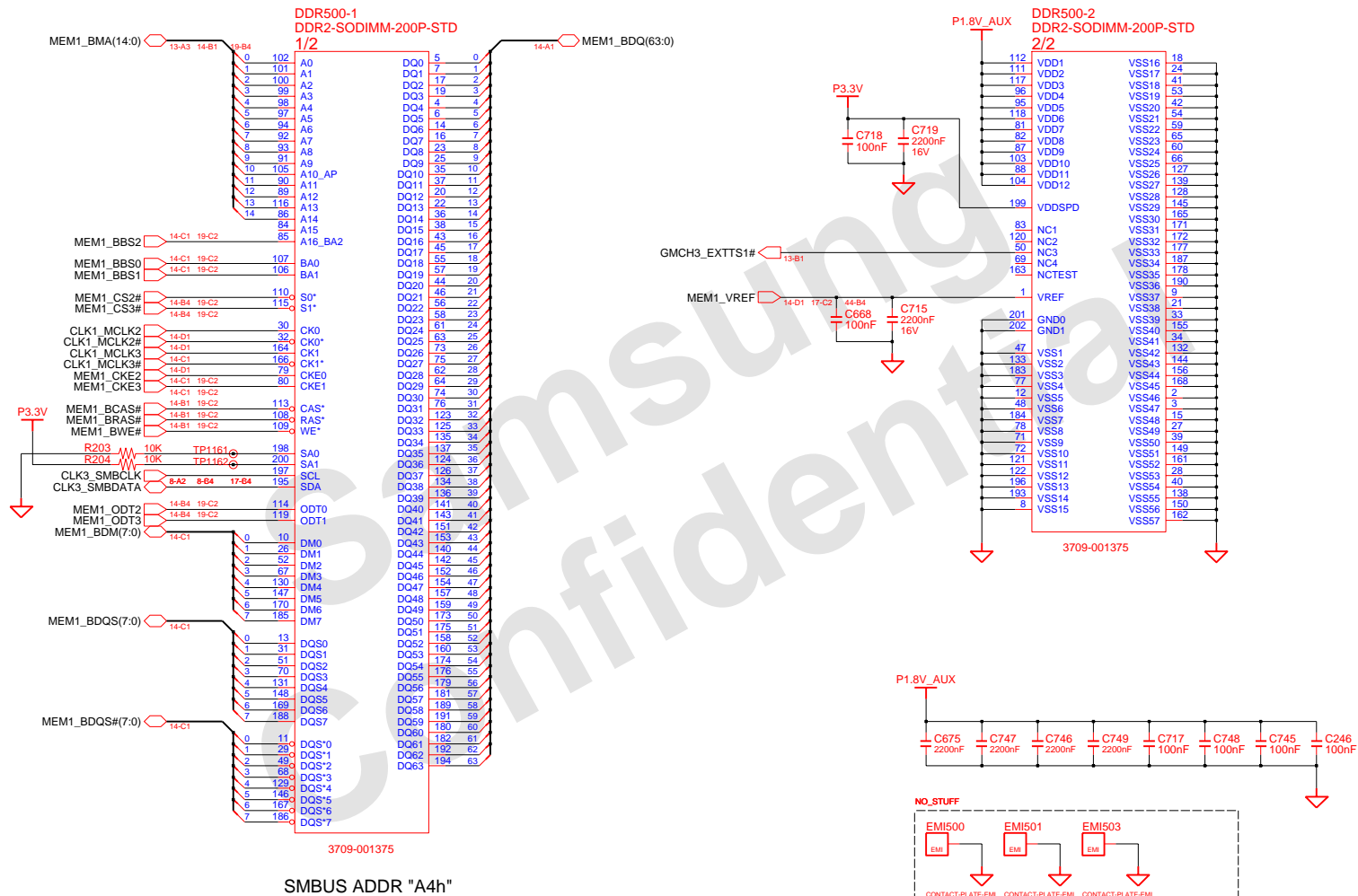

DRAW	ZHOU JUN	DATE	4/10/2007	TITLE	TORINO 2	SAMSUNG ELECTRONICS
CHECK	GUO LEI	DEV. STEP	MP		MAIN	
APPROVAL	KEVIN LEE	REV	1.1		DDR2 SODIMM (BOTTOM)	PART NO. BA41-00727/8A
MODULE CODE		LAST EDIT			March 28, 2007 3:33:29 PM	PAGE 18 OF 54

SAMSUNG PROPRIETARY
 THIS DOCUMENT CONTAINS CONFIDENTIAL
 PROPRIETARY INFORMATION THAT IS
 SAMSUNG ELECTRONICS CO'S PROPERTY.
 DO NOT DISCLOSE TO OR DUPLICATE FOR OTHERS
 EXCEPT AS AUTHORIZED BY SAMSUNG.

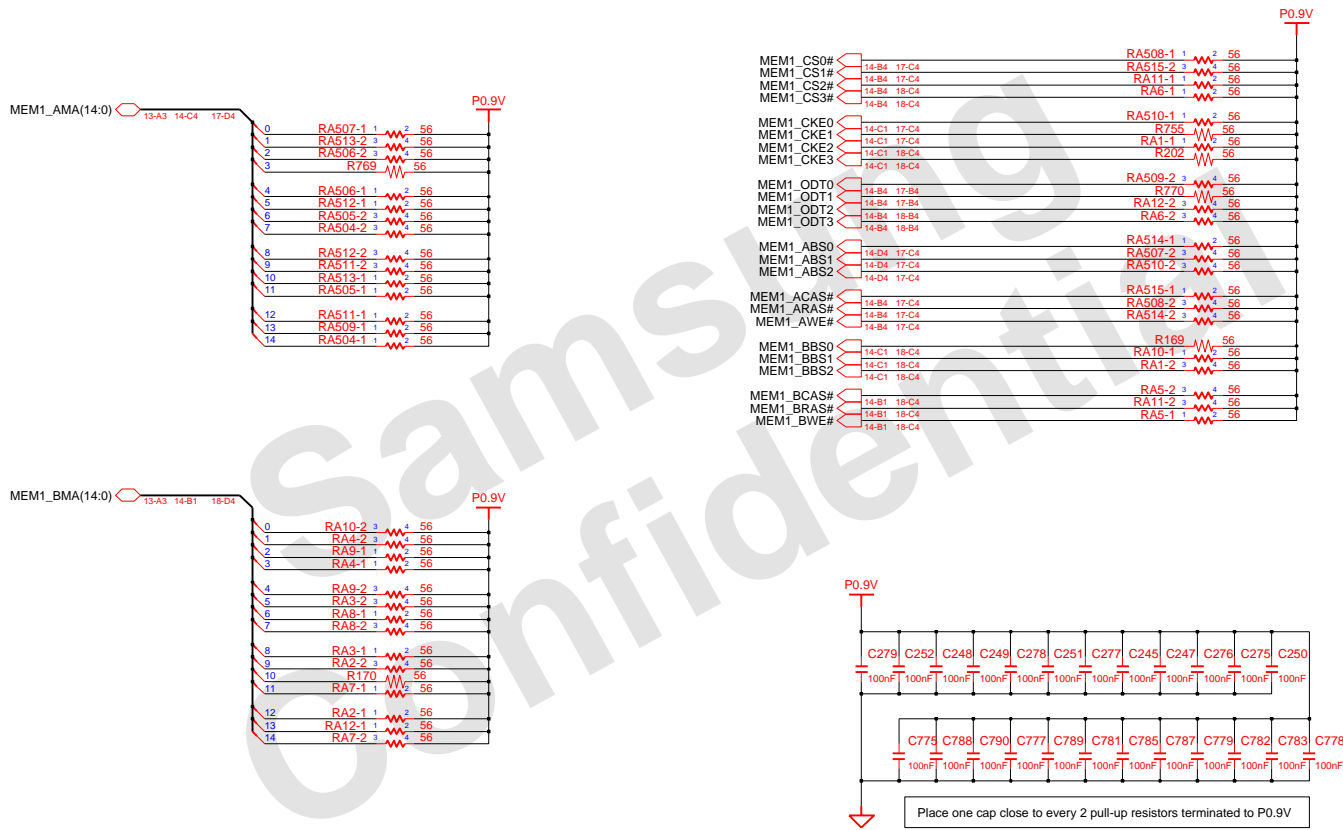

DRAW	ZHOU JUN	DATE	4/10/2007	TITLE	TORINO 2	SAMSUNG ELECTRONICS
CHECK	GUO LEI	DEV. STEP	MP	MAIN		
APPROVAL	KEVIN LEE	REV	1,1	DDR2 TERMINATION	PART NO.	BA41-00727/8A
MODULE CODE		LAST EDIT		March 28, 2007 3:33:29 PM	PAGE	19 OF 54

SAMSUNG PROPRIETARY
 THIS DOCUMENT CONTAINS CONFIDENTIAL
 PROPRIETARY INFORMATION THAT IS
 SAMSUNG ELECTRONICS CO'S PROPERTY.
 DO NOT DISCLOSE TO OR DUPLICATE FOR OTHERS
 EXCEPT AS AUTHORIZED BY SAMSUNG.

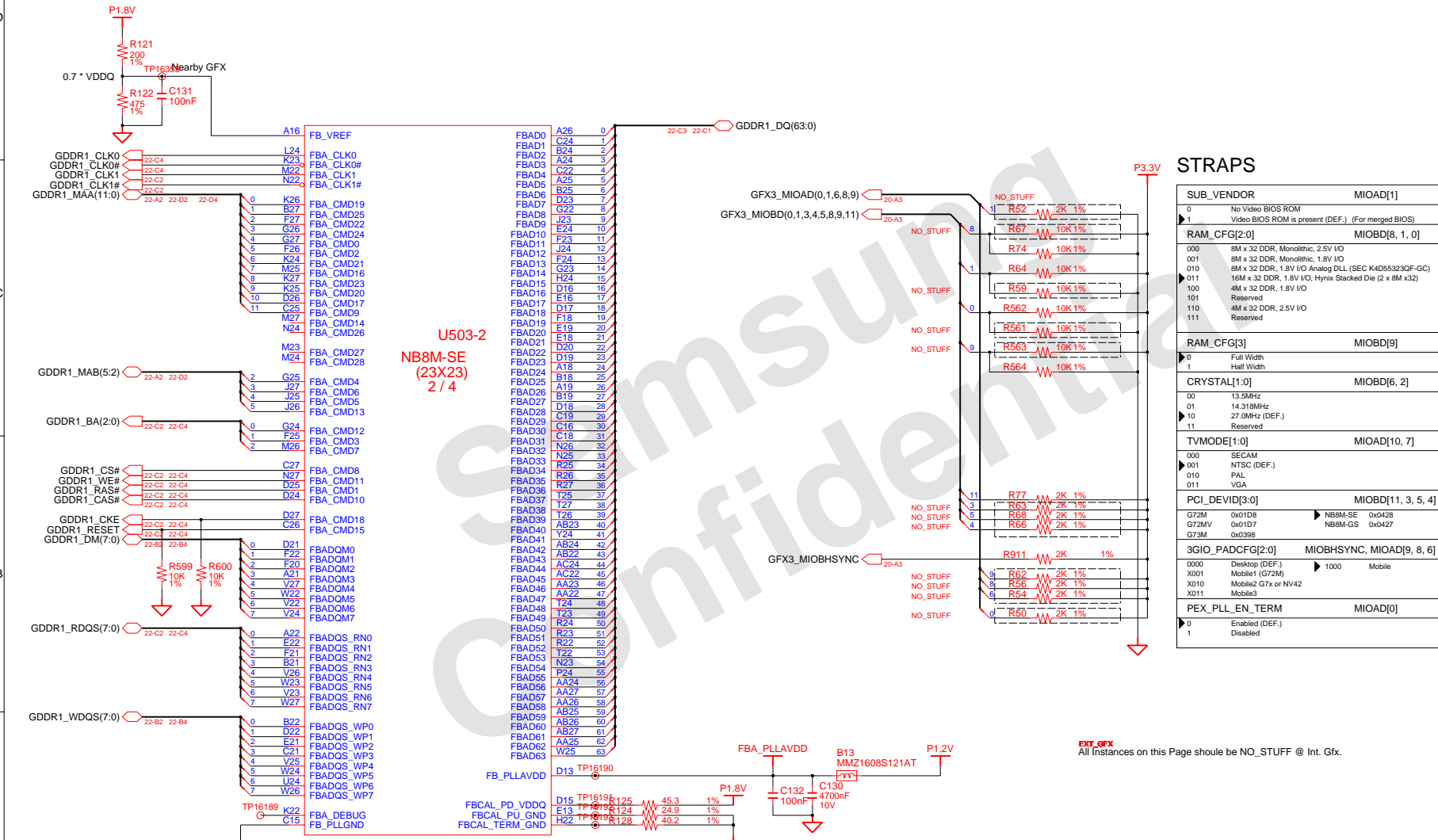

FBCAL_PU_GND pull down resistor
 NB8M: 24.9 ohm (2007-007302)
 G72M: 33 ohm (2007-001292)

DRAW	ZHOU JUN	DATE	4/10/2007	TITLE	TORINO 2	SAMSUNG ELECTRONICS
CHECK	GUO LEI	DEV_STEP	MP	MAIN		
APPROVAL	KEVIN LEE	REV	1.1	GFX (2)		
MODULE CODE		LAST ENT				
					March 28, 2007 3:33:29 PM	PAGE 21 OF 54

SAMSUNG PROPRIETARY
 THIS DOCUMENT CONTAINS CONFIDENTIAL
 PROPRIETARY INFORMATION THAT IS
 SAMSUNG ELECTRONICS CO'S PROPERTY.
 DO NOT DISCLOSE TO OR DUPLICATE FOR OTHERS
 EXCEPT AS AUTHORIZED BY SAMSUNG.

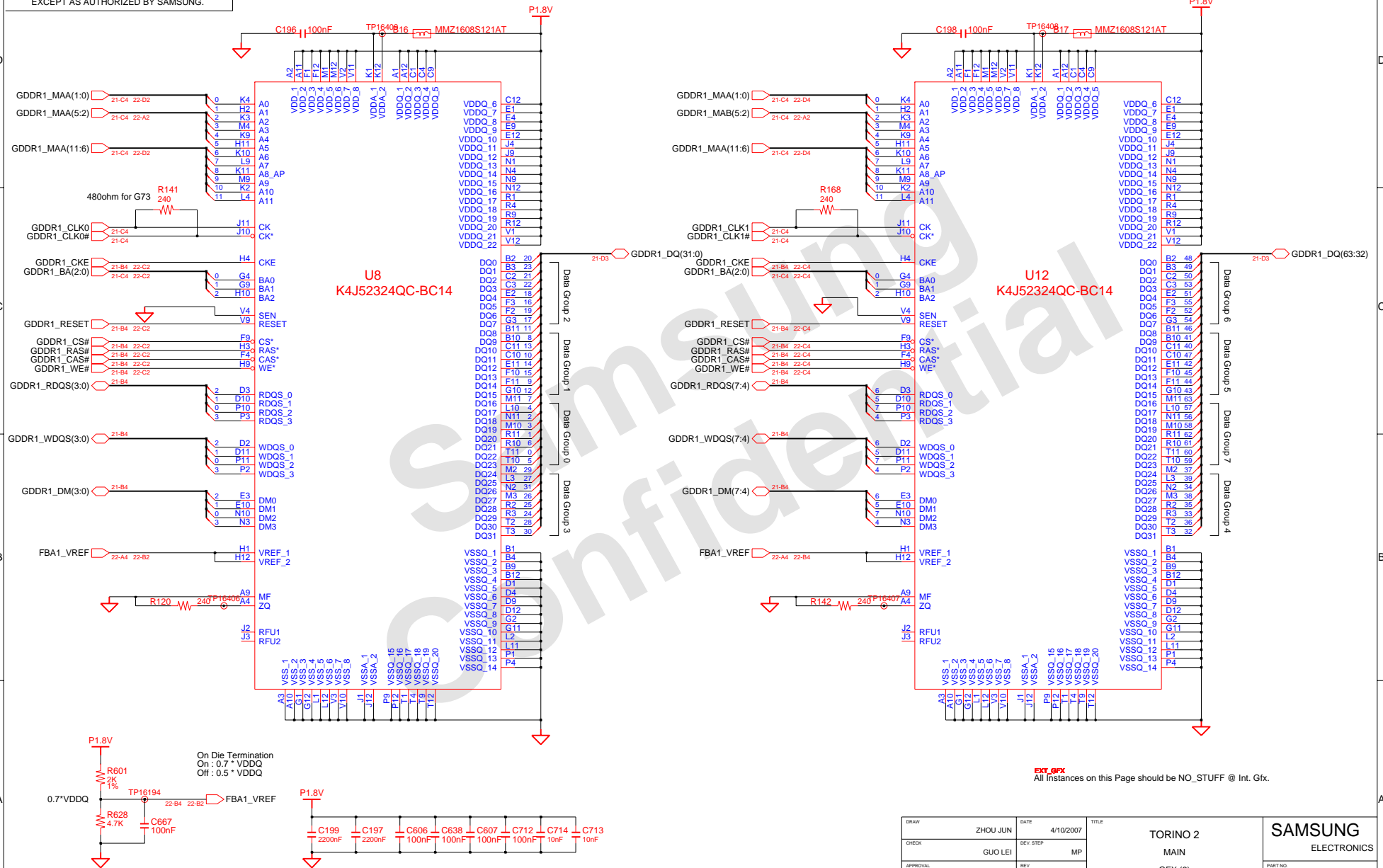

EXT GFX
 All instances on this Page should be NO_STUFF @ Int. Gfx.

DRAW	ZHOU JUN	DATE	4/10/2007	TITLE	TORINO 2	SAMSUNG ELECTRONICS
CHECK	GUO LEI	DEV STEP	MP	MAIN	MP	
APPROVAL	KEVIN LEE	REV	1.1	GFX (3)	PART NO.	BA41-00727/8A
MODULE CODE		LAST EDIT			March 28, 2007 3:33:29 PM	PAGE 22 OF 54

SAMSUNG PROPRIETARY
 THIS DOCUMENT CONTAINS CONFIDENTIAL
 PROPRIETARY INFORMATION THAT IS
 SAMSUNG ELECTRONICS CO'S PROPERTY.
 DO NOT DISCLOSE TO OR DUPLICATE FOR OTHERS
 EXCEPT AS AUTHORIZED BY SAMSUNG.

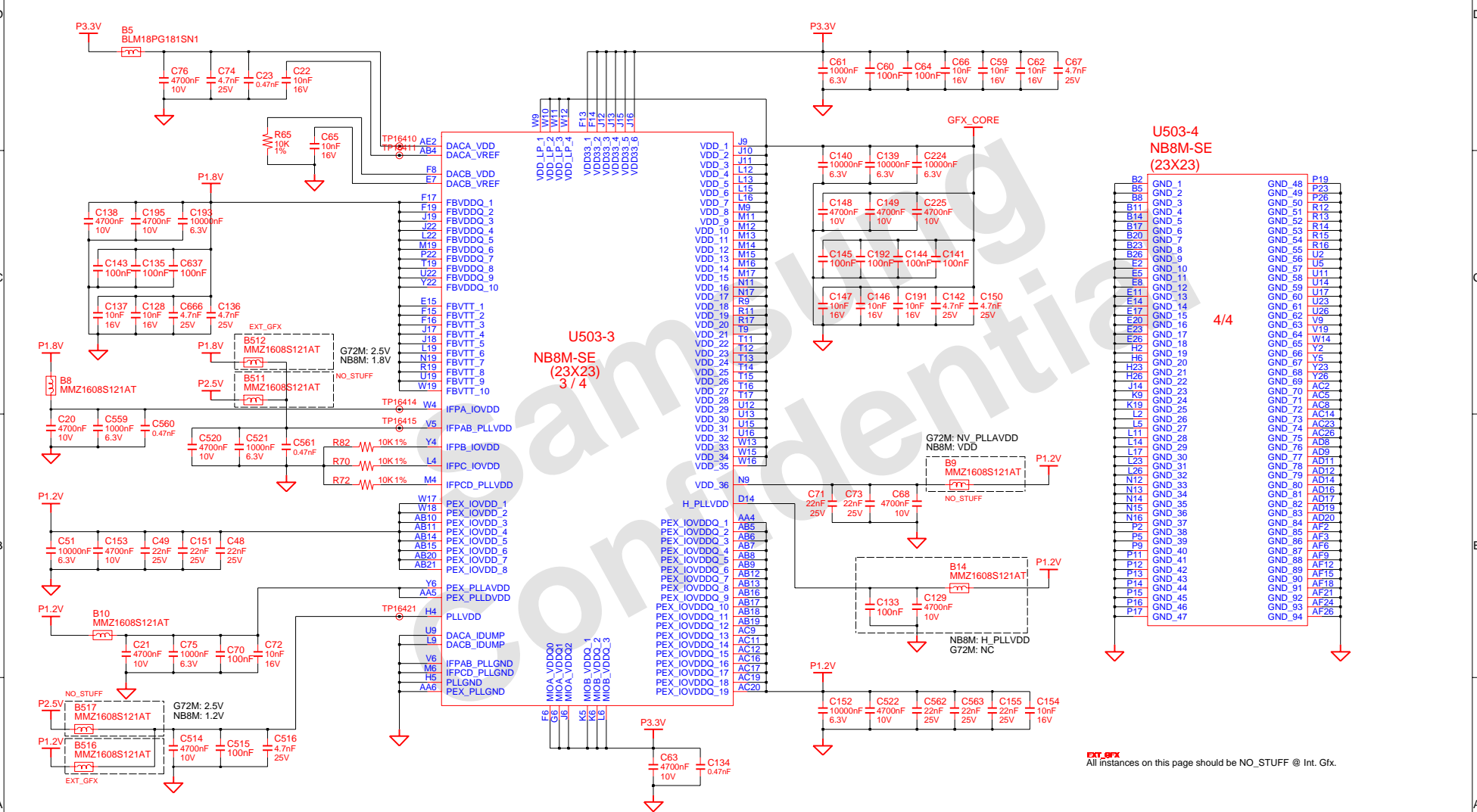

EXT_GFX
 All instances on this page should be NO_STUFF @ Int. Gfx.

DRAW	ZHOU JUN	DATE	4/10/2007	TITLE	TORINO 2	SAMSUNG ELECTRONICS
CHECK	GUO LEI	DEV_STEP	MP	MAIN	MAIN	
APPROVAL	KEVIN LEE	REV	1.1	GFX (4)		PART NO. BA41-00727/8A
MODULE CODE		LAST EDIT			March 28, 2007 3:33:29 PM	PAGE 23 OF 54

SAMSUNG PROPRIETARY
 THIS DOCUMENT CONTAINS CONFIDENTIAL
 PROPRIETARY INFORMATION THAT IS
 SAMSUNG ELECTRONICS CO'S PROPERTY.
 DO NOT DISCLOSE TO OR DUPLICATE FOR OTHERS
 EXCEPT AS AUTHORIZED BY SAMSUNG.

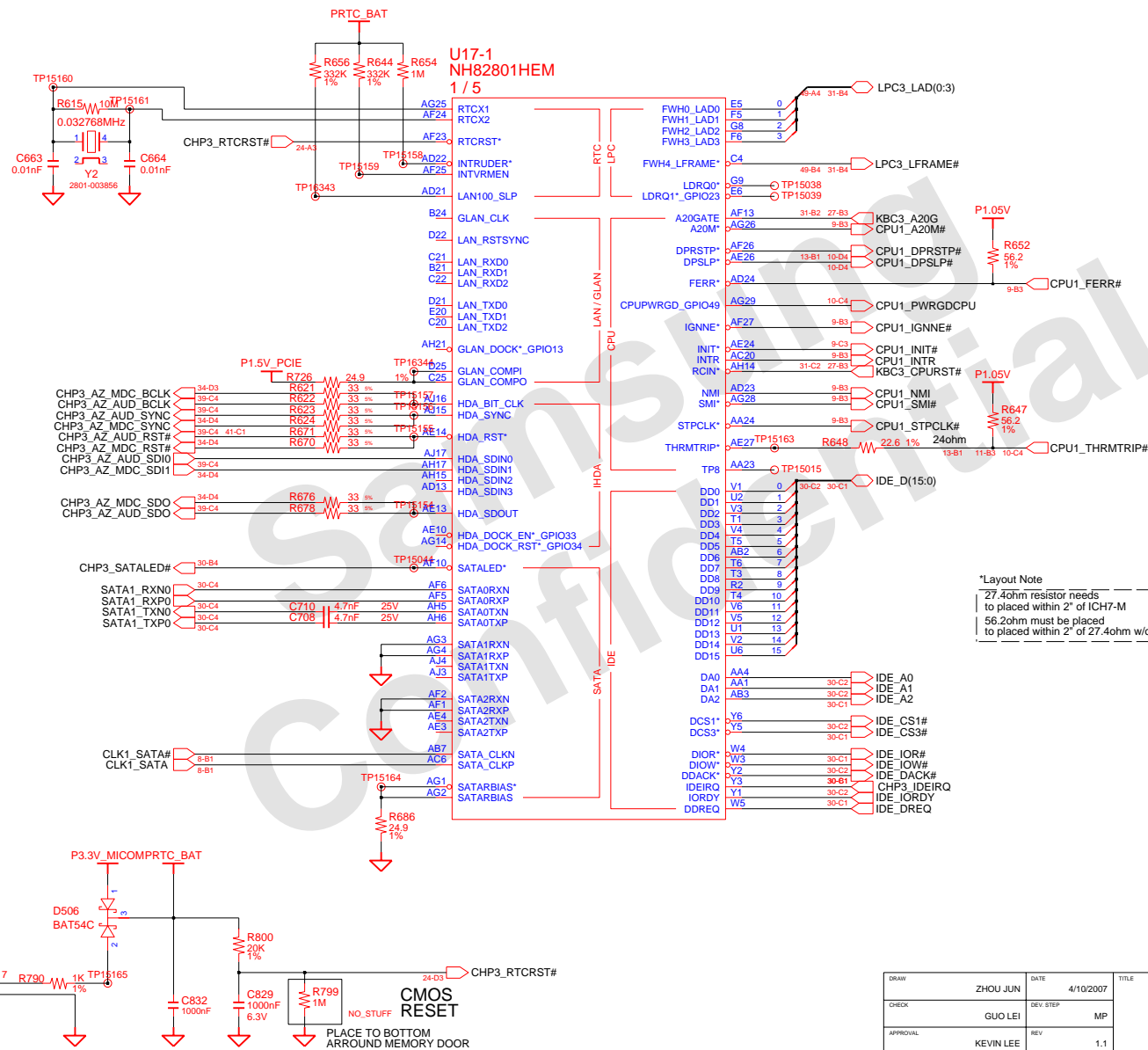

***Layout Note**
 27.4ohm resistor needs
 to be placed within 2" of ICH7-M
 56.2ohm must be placed
 to be placed within 2" of 27.4ohm w/o stub

DRAW	ZHOU JUN	DATE	4/10/2007	TITLE	TORINO 2	SAMSUNG ELECTRONICS
CHECK	GUO LEI	DEV_STEP	MP	MAIN	PART NO.	
APPROVAL	KEVIN LEE	REV	1,1	ICH8M(1)	BA41-00727/8A	
MODULE CODE		LAST EDIT	March 28, 2007 3:33:29 PM	PAGE	24	OF 54

SAMSUNG PROPRIETARY
 THIS DOCUMENT CONTAINS CONFIDENTIAL
 PROPRIETARY INFORMATION THAT IS
 SAMSUNG ELECTRONICS CO.'S PROPERTY.
 DO NOT DISCLOSE TO OR DUPLICATE FOR OTHERS
 EXCEPT AS AUTHORIZED BY SAMSUNG.

AC caps : PCIe need to be within 250mils of the driver
 Resistor for Test : Place Stuffing Option to minimize stubs

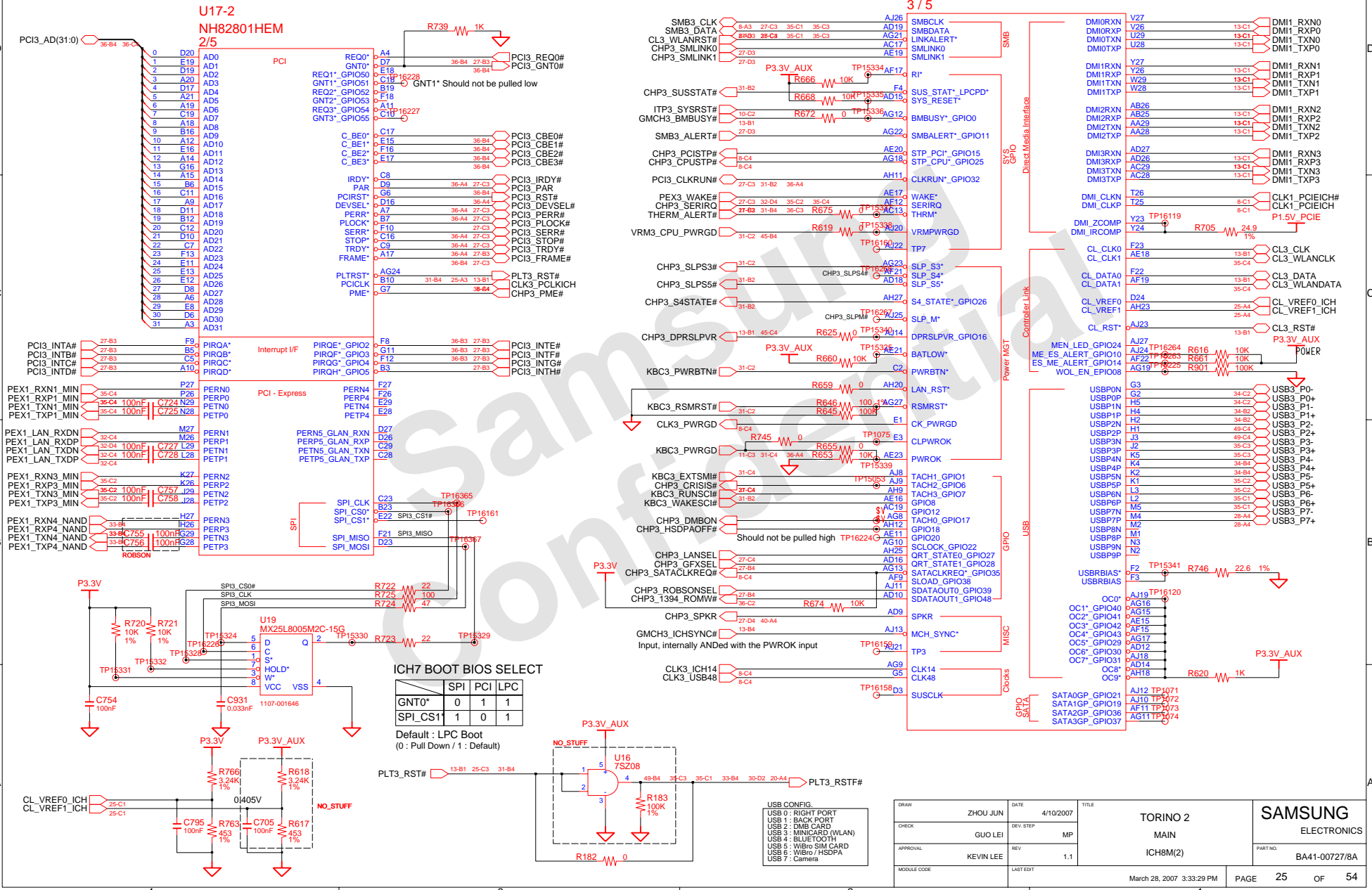

DRAW	ZHOU JUN	DATE	4/10/2007	TITLE	TORINO 2
CHECK	GUO LEI	DEV STEP	MP		MAIN
APPROVAL	KEVIN LEE	REV	1.1		ICH8M(2)
MODULE CODE		LAST EDIT	March 28, 2007 3:33:29 PM	PAGE	25 OF 54

SAMSUNG
ELECTRONICS
PART NO. BA41-00727/8A

SAMSUNG PROPRIETARY
THIS DOCUMENT CONTAINS CONFIDENTIAL
PROPRIETARY INFORMATION THAT IS
SAMSUNG ELECTRONICS CO'S PROPERTY.
DO NOT DISCLOSE TO OR DUPLICATE FOR OTHERS
EXCEPT AS AUTHORIZED BY SAMSUNG.

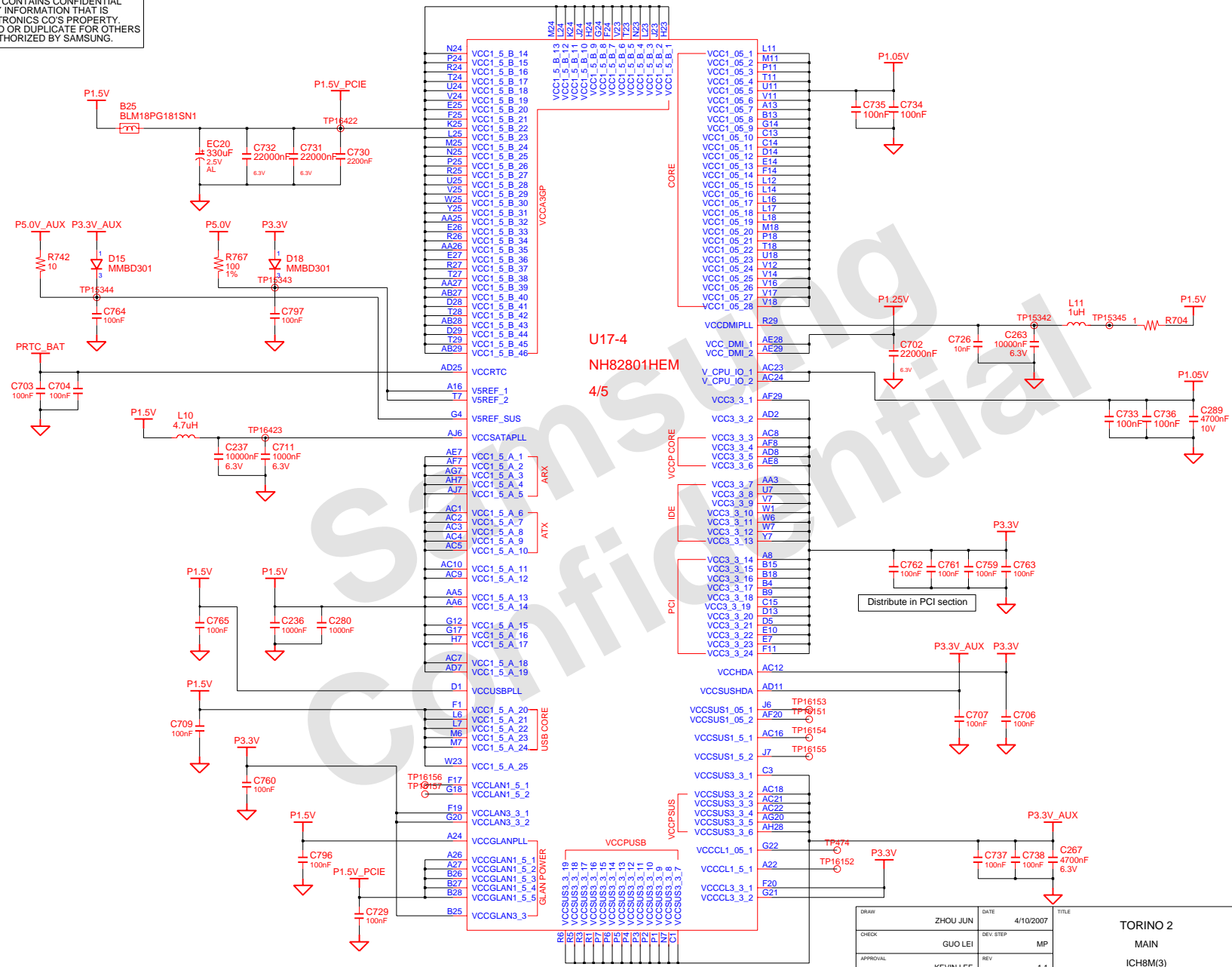

U17-4
NH82801HEM
4/5

DRAW	ZHOU JUN	DATE	4/10/2007	TITLE	TORINO 2	SAMSUNG ELECTRONICS
CHECK	GUO LEI	DEV STEP	MP	MAIN	ICH8M(3)	
APPROVAL	KEVIN LEE	REV	1.1			PART NO. BA41-00727/8A
MODULE CODE		LAST EDIT				
March 28, 2007 3:33:29 PM				PAGE	26	OF 54

SAMSUNG PROPRIETARY
 THIS DOCUMENT CONTAINS CONFIDENTIAL
 PROPRIETARY INFORMATION THAT IS
 SAMSUNG ELECTRONICS CO.'S PROPERTY.
 DO NOT DISCLOSE TO OR DUPLICATE FOR OTHERS
 EXCEPT AS AUTHORIZED BY SAMSUNG.

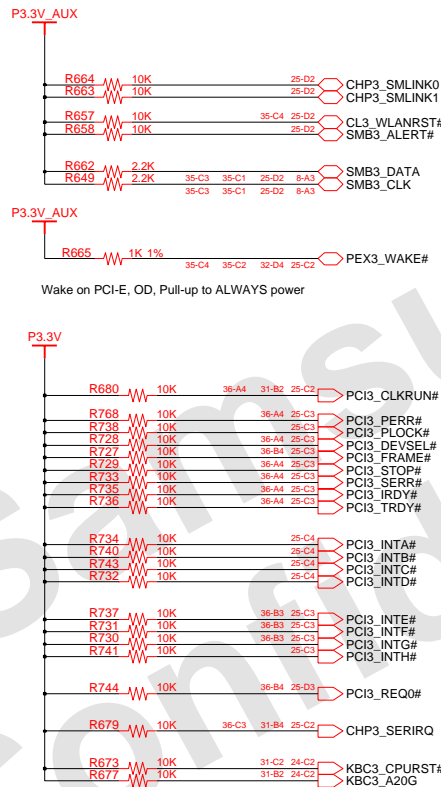
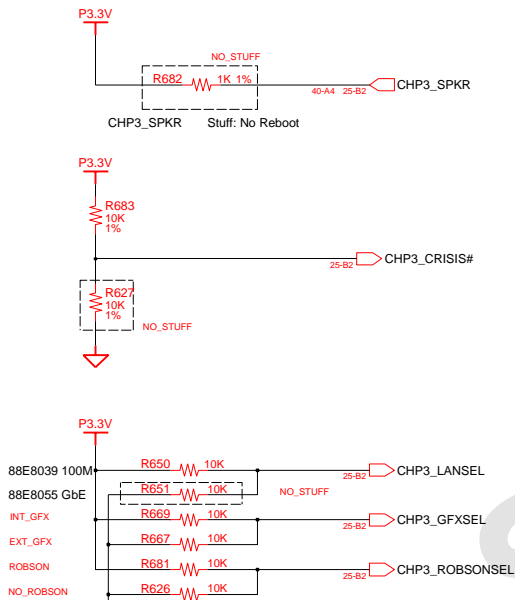

A23	VSS_1	VSS_126	N26
A5	VSS_2	VSS_127	N27
AA2	VSS_3	VSS_128	N4
AA7	VSS_4	VSS_129	N5
A6	VSS_5	VSS_130	N6
AB1	VSS_6	VSS_131	P12
AB24	VSS_7	VSS_132	P13
AC11	VSS_8	VSS_133	P14
AC14	VSS_9	VSS_134	P15
AC25	VSS_10	VSS_135	P16
AC26	VSS_11	VSS_136	P17
AC27	VSS_12	VSS_137	P23
AD17	VSS_13	VSS_138	P28
AD20	VSS_14	VSS_139	P29
AD28	VSS_15	VSS_140	R11
AD29	VSS_16	VSS_141	R12
AD3	VSS_17	VSS_142	R13
AD4	VSS_18	VSS_143	R14
AD6	VSS_19	VSS_144	R15
AE1	VSS_20	VSS_145	R16
AE12	VSS_21	VSS_146	R17
AE2	VSS_22	VSS_147	R18
AE22	VSS_23	VSS_148	R4
AD1	VSS_24	VSS_149	R28
AE25	VSS_25	VSS_150	T12
AE5	VSS_26	VSS_151	T13
AE6	VSS_27	VSS_152	T14
AE9	VSS_28	VSS_153	T15
AF14	VSS_29	VSS_154	T16
AF16	VSS_30	VSS_155	T17
AF18	VSS_31	VSS_156	T2
AF3	VSS_32	VSS_157	U13
AF4	VSS_33	VSS_158	U14
AG5	VSS_34	VSS_159	U15
AG6	VSS_35	VSS_160	U16
AH10	VSS_36	VSS_161	U17
AH13	VSS_37	VSS_162	U23
AH16	VSS_38	VSS_163	U26
AH19	VSS_39	VSS_164	U27
AH2	VSS_40	VSS_165	U3
AF26	VSS_41	VSS_166	U5
AH22	VSS_42	VSS_167	V13
AH24	VSS_43	VSS_168	V15
AH26	VSS_44	VSS_169	V28
AH3	VSS_45	VSS_170	V29
AH4	VSS_46	VSS_171	W2
AH8	VSS_47	VSS_172	W26
AJ5	VSS_48	VSS_173	W27
B11	VSS_49	VSS_174	Y28
B14	VSS_50	VSS_175	Y29
B17	VSS_51	VSS_176	Y4
B2	VSS_52	VSS_177	AB4
B20	VSS_53	VSS_178	AB23
B22	VSS_54	VSS_179	AB5
C24	VSS_55	VSS_180	AB6
C26	VSS_56	VSS_181	AD5
C27	VSS_57	VSS_182	U4
C6	VSS_58	VSS_183	W24
D12	VSS_59	VSS_184	
D15	VSS_60	VSS_NCTF1	A1
D18	VSS_61	VSS_NCTF2	A2
D2	VSS_62	VSS_NCTF3	A28
D4	VSS_63	VSS_NCTF4	A29
E21	VSS_64	VSS_NCTF5	AH1
E24	VSS_65	VSS_NCTF6	AH29
E25	VSS_66	VSS_NCTF7	AJ1
E4	VSS_67	VSS_NCTF8	AJ2
E9	VSS_68	VSS_NCTF9	AJ28
F15	VSS_69	VSS_NCTF10	AJ29
E23	VSS_70	VSS_NCTF11	B1
F28	VSS_71	VSS_NCTF12	B29
F29	VSS_72		
F7	VSS_73		
G1	VSS_74		
G10	VSS_75		
G13	VSS_76		
G19	VSS_77		
G23	VSS_78		
G28	VSS_79		
G36	VSS_80		
G37	VSS_81		
H25	VSS_82		
H28	VSS_83		
H3	VSS_84		
H9	VSS_85		
HE	VSS_86		
HE	VSS_87		
HE	VSS_88		
HE	VSS_89		
HE	VSS_90		
J27	VSS_91		
J4	VSS_92		
K21	VSS_93		
K23	VSS_94		
K28	VSS_95		
K39	VSS_96		
K8	VSS_97		
K8	VSS_98		
L6	VSS_99		

U17-5
 NH82801HEM
 5/5

DRAW	ZHOU JUN	DATE	4/10/2007	TITLE	TORINO 2	SAMSUNG ELECTRONICS PART NO. BA41-00727/8A
CHECK	GUO LEI	DEV STEP	MP		MAIN	
APPROVAL	KEVIN LEE	REV	1,1		ICH8M(4)	
MODULE CODE		LAST ENT				
				March 28, 2007 3:33:29 PM	PAGE	27 OF 54

SAMSUNG PROPRIETARY
 THIS DOCUMENT CONTAINS CONFIDENTIAL
 PROPRIETARY INFORMATION THAT IS
 SAMSUNG ELECTRONICS CO'S PROPERTY.
 DO NOT DISCLOSE TO OR DUPLICATE FOR OTHERS
 EXCEPT AS AUTHORIZED BY SAMSUNG.

WXGA LCD CONNECTOR

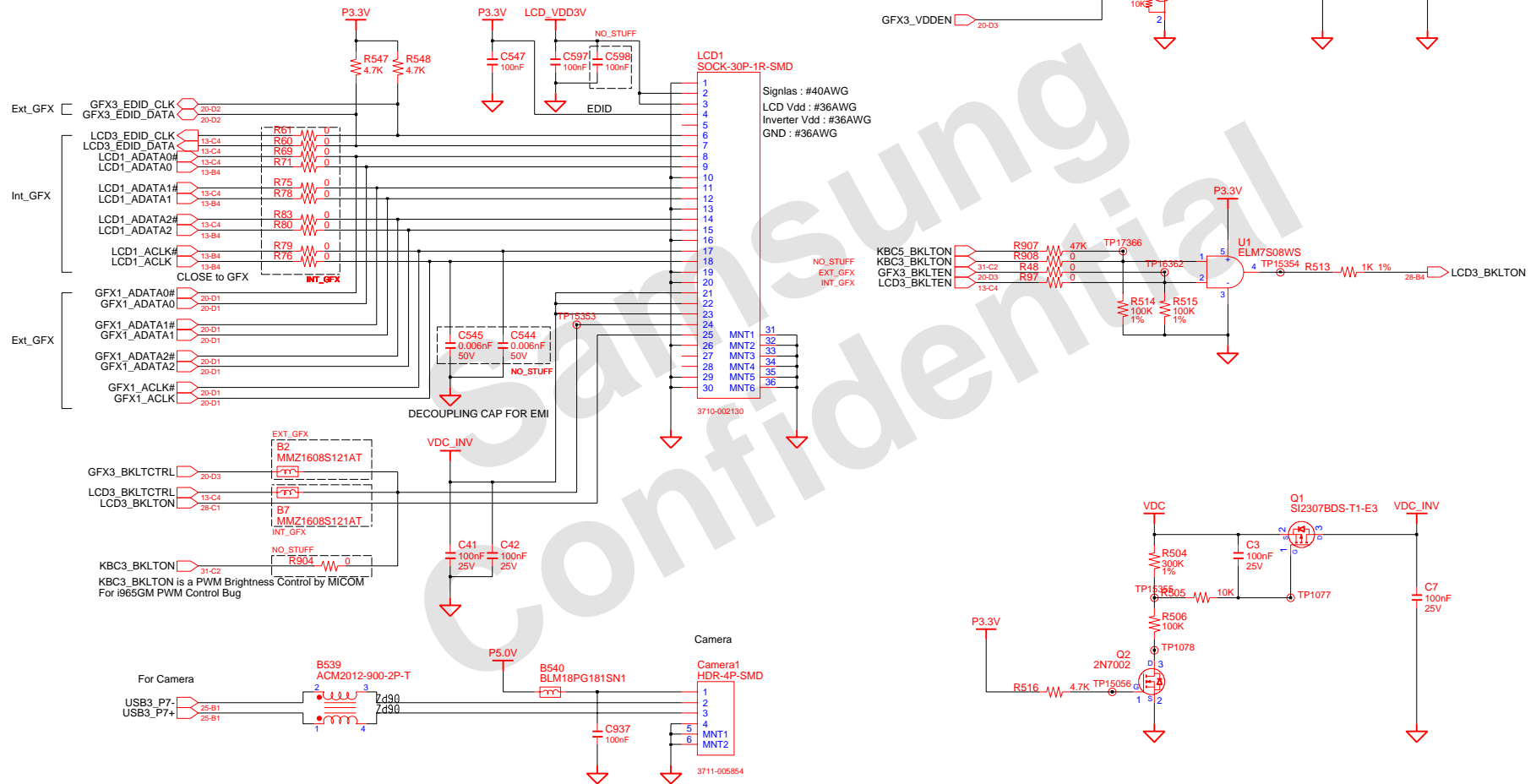

DRAW	ZHOU JUN	DATE	4/10/2007	TITLE	TORINO 2	SAMSUNG ELECTRONICS
CHECK	GUO LEI	DEV. STEP	MP	MAIN	PART NO.	
APPROVAL	KEVIN LEE	REV	1.1	LVDS	BA41-00727/8A	
MODULE CODE		LAST ENT			March 28, 2007 3:33:29 PM	PAGE 28 OF 54

SAMSUNG PROPRIETARY
 THIS DOCUMENT CONTAINS CONFIDENTIAL
 PROPRIETARY INFORMATION THAT IS
 SAMSUNG ELECTRONICS CO'S PROPERTY.
 DO NOT DISCLOSE TO OR DUPLICATE FOR OTHERS
 EXCEPT AS AUTHORIZED BY SAMSUNG.

CRT CONNECTOR

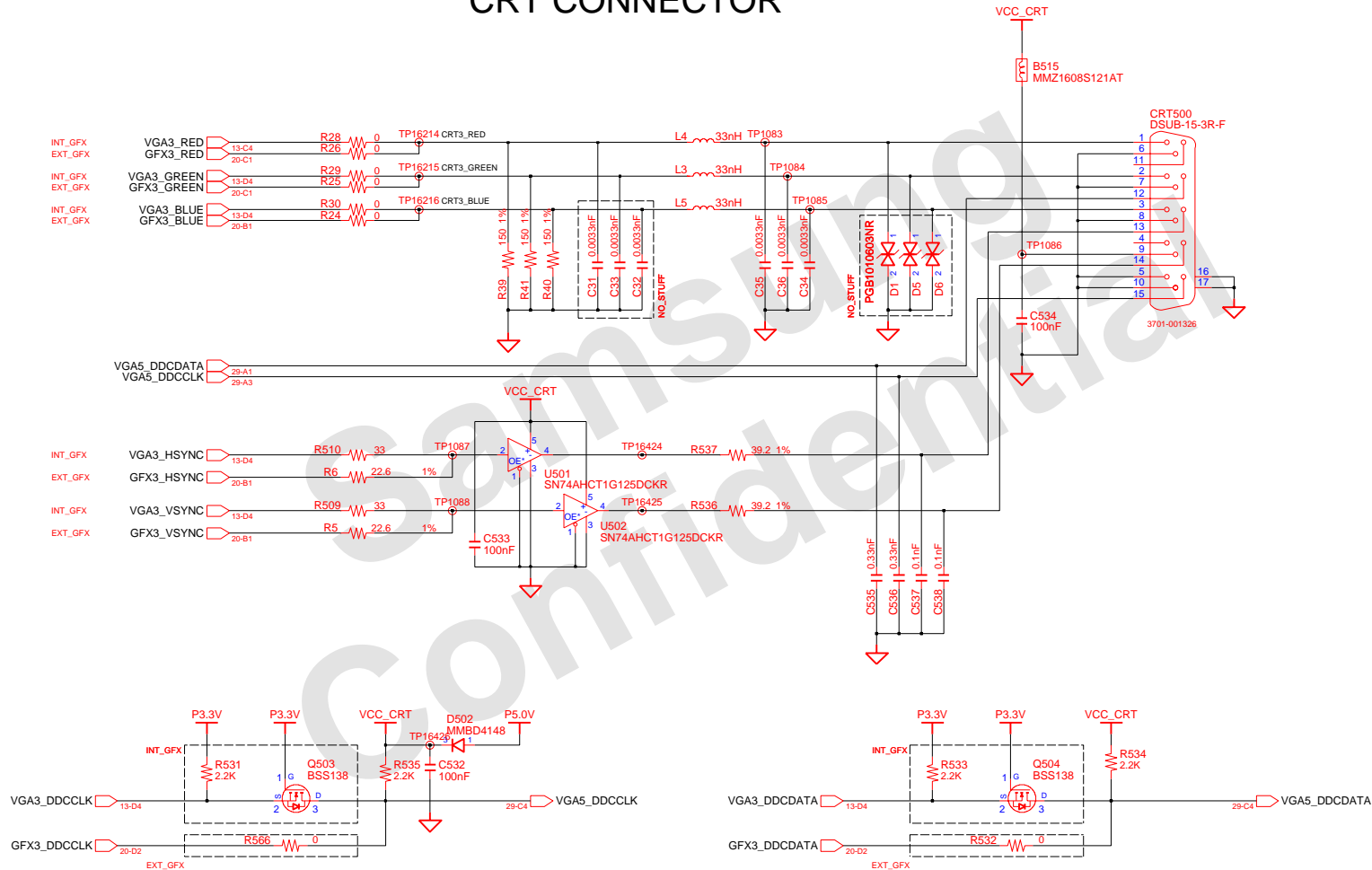

DRAW	ZHOU JUN	DATE	4/10/2007	TITLE	TORINO 2	SAMSUNG ELECTRONICS
CHECK	GUO LEI	DEV. STEP	MP	MAIN		
APPROVAL	KEVIN LEE	REV	1,1	CRT	PART NO.	
MODULE CODE		LAST EDIT			BA41-00727/8A	
				March 28, 2007 3:33:29 PM	PAGE	29 OF 54

SAMSUNG PROPRIETARY
 THIS DOCUMENT CONTAINS CONFIDENTIAL
 PROPRIETARY INFORMATION THAT IS
 SAMSUNG ELECTRONICS CO'S PROPERTY.
 DO NOT DISCLOSE TO OR DUPLICATE FOR OTHERS
 EXCEPT AS AUTHORIZED BY SAMSUNG.

Main to HDD

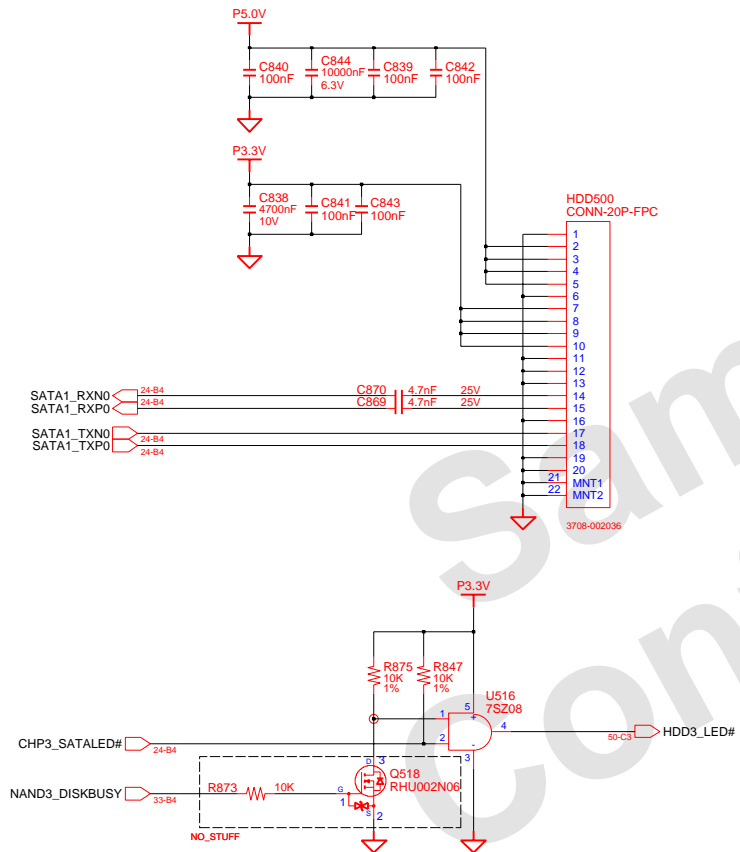

Main to ODD

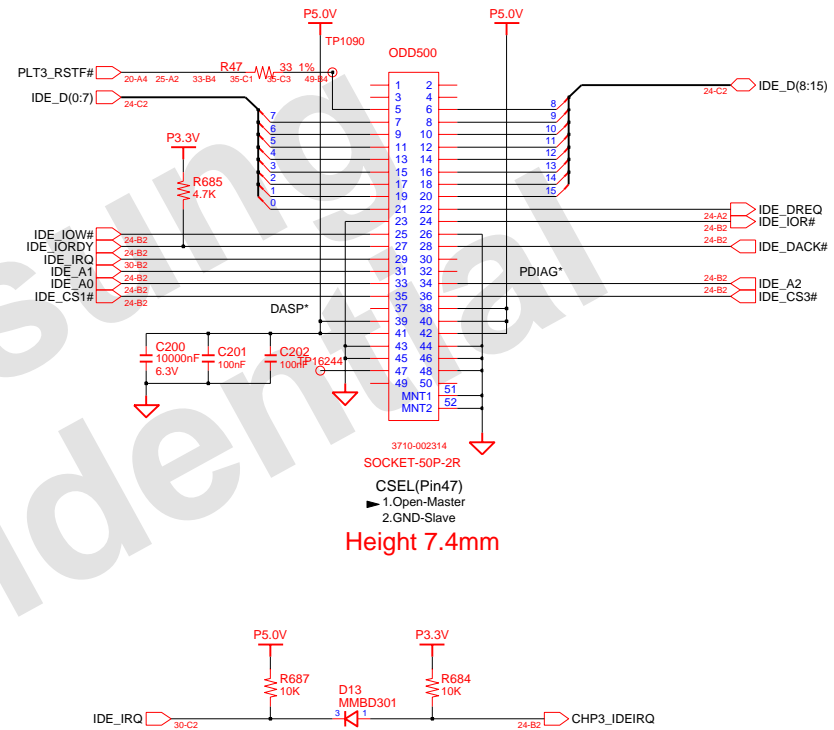

DRAW	ZHOU JUN	DATE	4/10/2007	TITLE	TORINO 2	SAMSUNG ELECTRONICS
CHECK	GUO LEI	DEV. STEP	MP	MAIN	PART NO.	
APPROVAL	KEVIN LEE	REV	1,1	IDE	BA41-00727/8A	
MODULE CODE		LAST EDIT	March 28, 2007 3:33:29 PM	PAGE	30	OF 54

SAMSUNG PROPRIETARY
 THIS DOCUMENT CONTAINS CONFIDENTIAL
 PROPRIETARY INFORMATION THAT IS
 SAMSUNG ELECTRONICS CO'S PROPERTY.
 DO NOT DISCLOSE TO OR DUPLICATE FOR OTHERS
 EXCEPT AS AUTHORIZED BY SAMSUNG.

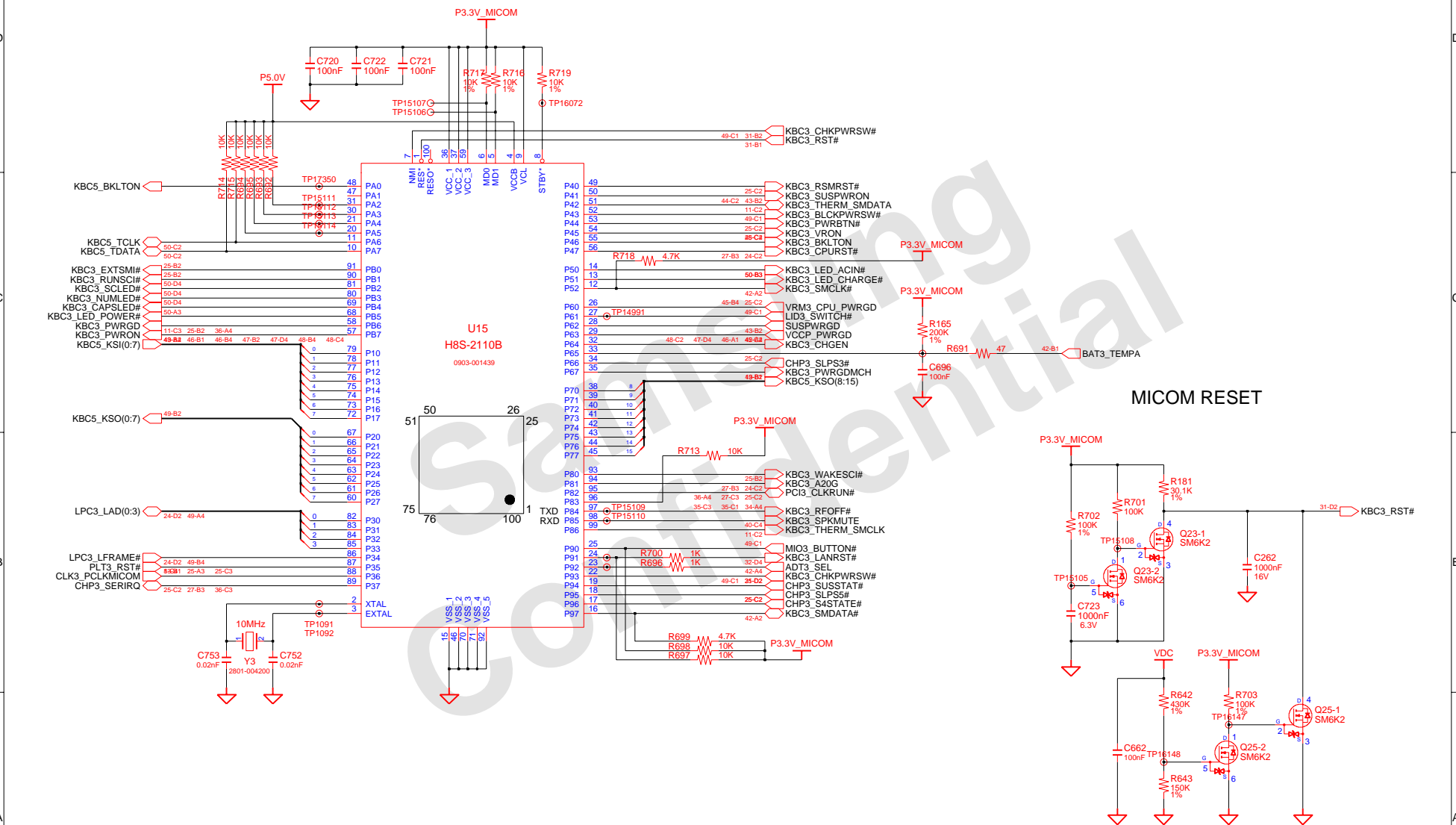

DRAW	ZHOU JUN	DATE	4/10/2007	TITLE	TORINO 2	SAMSUNG ELECTRONICS
CHECK	GUO LEI	DEV STEP	MP	MAIN	MICOM	
APPROVAL	KEVIN LEE	REV	1,1			PART NO. BA41-00727/8A
MODULE CODE		LAST ENT			March 28, 2007 3:33:29 PM	PAGE 31 OF 54

SAMSUNG PROPRIETARY
 THIS DOCUMENT CONTAINS CONFIDENTIAL
 PROPRIETARY INFORMATION THAT IS
 SAMSUNG ELECTRONICS CO'S PROPERTY.
 DO NOT DISCLOSE TO OR DUPLICATE FOR OTHERS
 EXCEPT AS AUTHORIZED BY SAMSUNG.

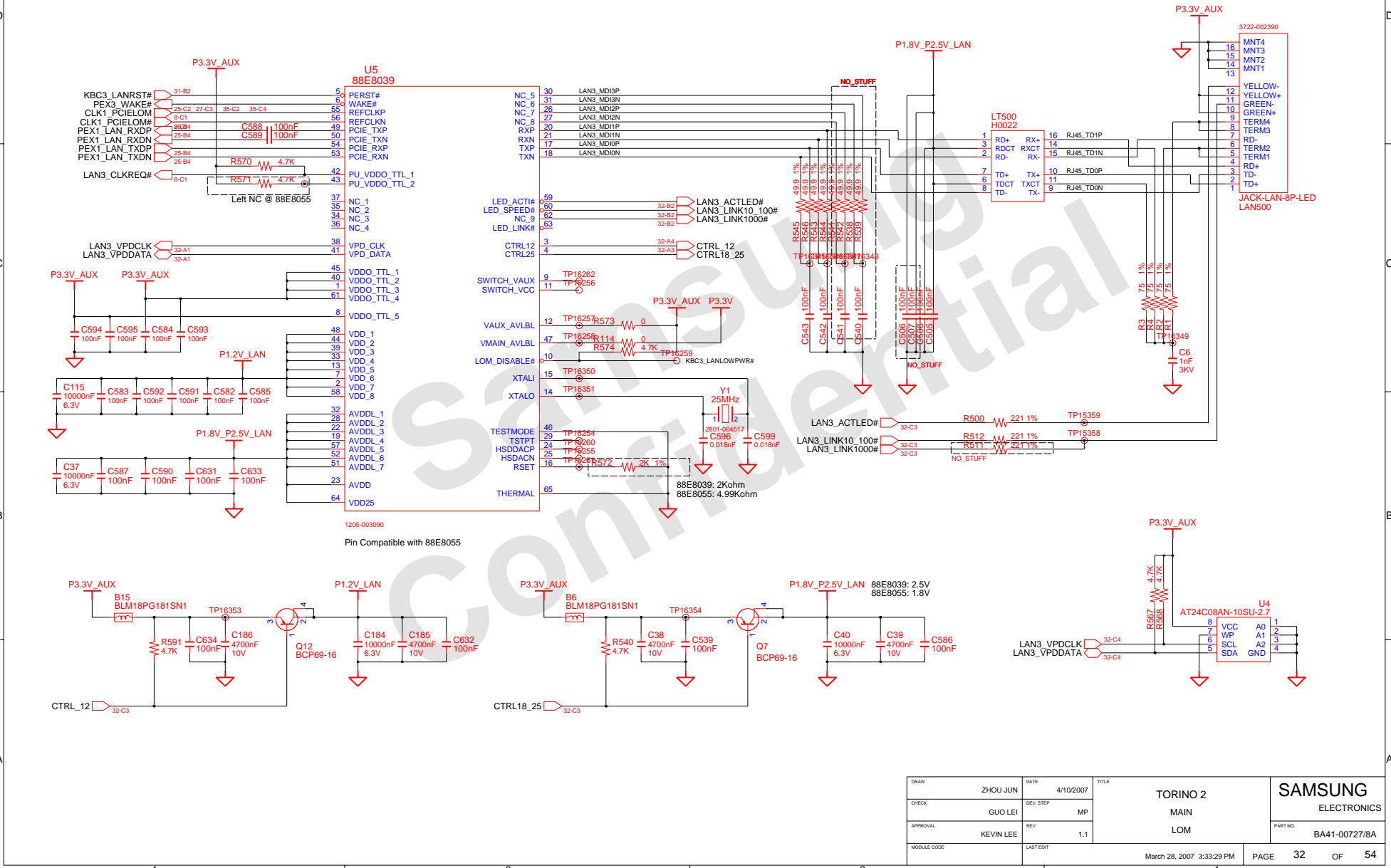

DRAW	ZHOU JUN	DATE	4/10/2007	TITLE	TORINO 2	SAMSUNG ELECTRONICS
CHECK	GUO LEI	DEV_STEP	MP	MAIN		
APPROVAL	KEVIN LEE	REV	1.1	LOM		
MODULE CODE		LAST EDIT				PART NO. BA41-00727/8A
March 28, 2007 3:33:29 PM						PAGE 32 OF 54

SAMSUNG PROPRIETARY
 THIS DOCUMENT CONTAINS CONFIDENTIAL
 PROPRIETARY INFORMATION THAT IS
 SAMSUNG ELECTRONICS CO'S PROPERTY.
 DO NOT DISCLOSE TO OR DUPLICATE FOR OTHERS
 EXCEPT AS AUTHORIZED BY SAMSUNG.

Robson

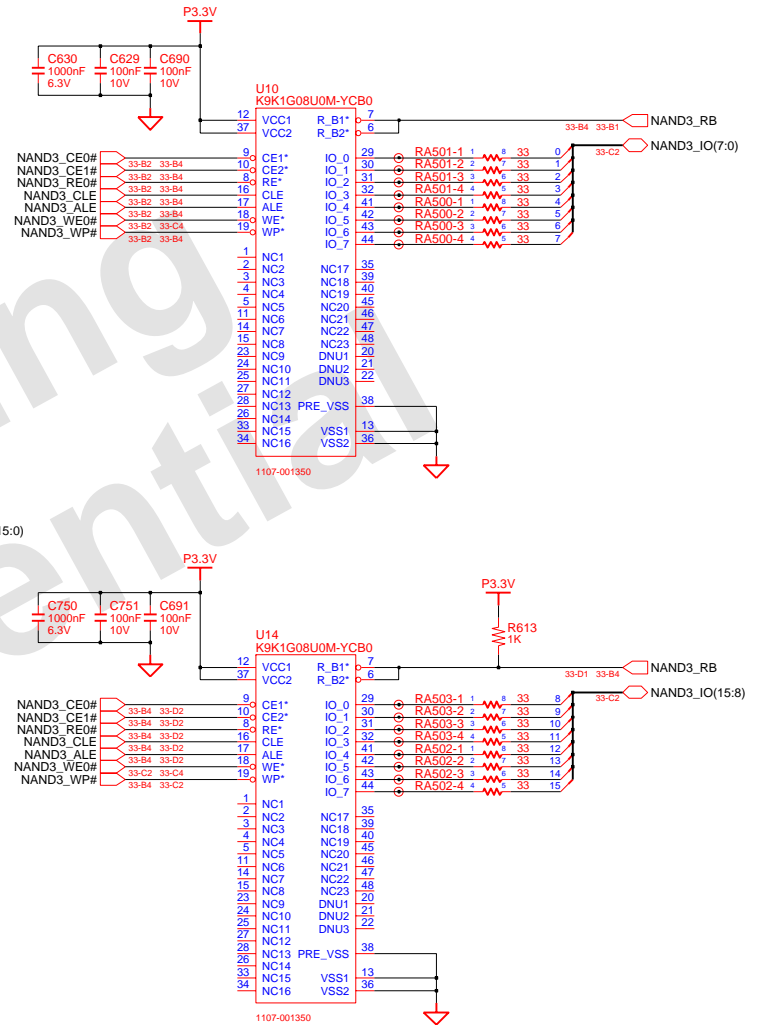
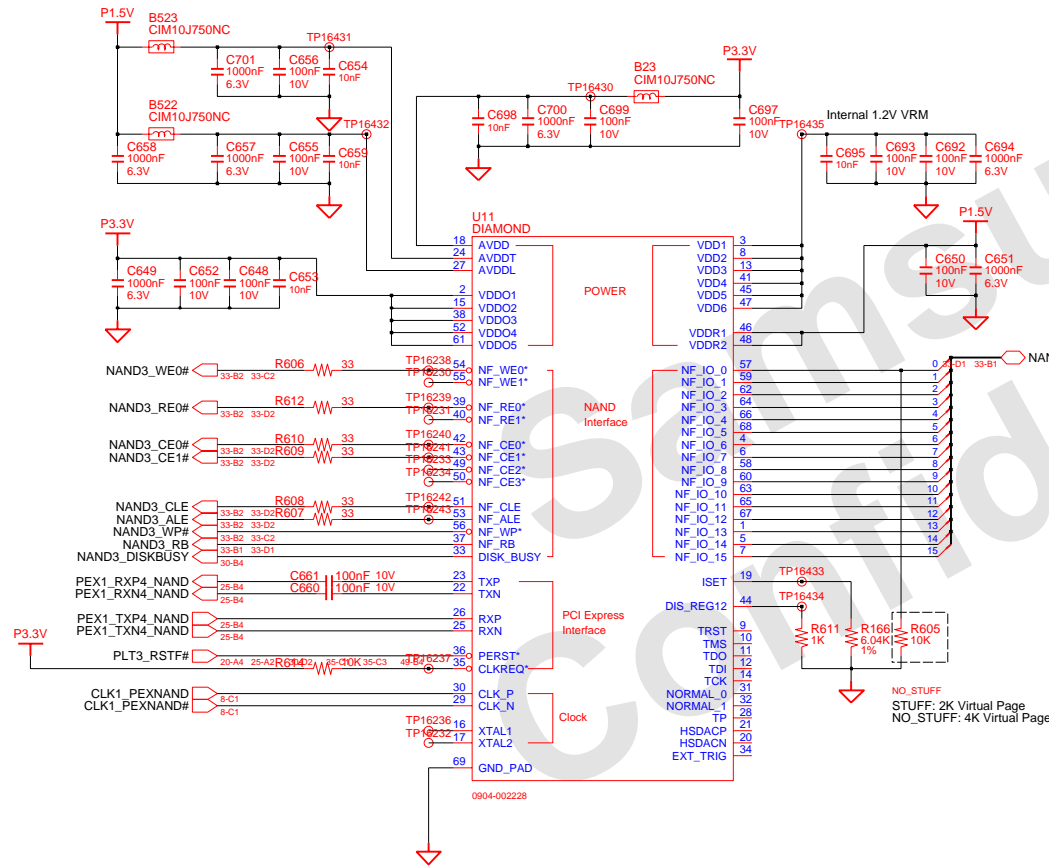

ROBSON
 All instances on this page should be NO_STUFF if ROBSON is N/A

DRAW	ZHOU JUN	DATE	4/10/2007	TITLE	TORINO 2	SAMSUNG ELECTRONICS PART NO. BA41-00727/8A
CHECK	GUO LEI	DEV_STEP	MP	MAIN	ROBSON	
APPROVAL	KEVIN LEE	REV	1.1			
MODULE CODE		LAST EDIT				
March 28, 2007 3:33:29 PM						PAGE 33 OF 54

SAMSUNG PROPRIETARY
 THIS DOCUMENT CONTAINS CONFIDENTIAL
 PROPRIETARY INFORMATION THAT IS
 SAMSUNG ELECTRONICS CO.'S PROPERTY.
 DO NOT DISCLOSE TO OR DUPLICATE FOR OTHERS
 EXCEPT AS AUTHORIZED BY SAMSUNG.

MDC connector

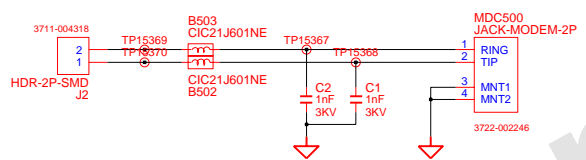
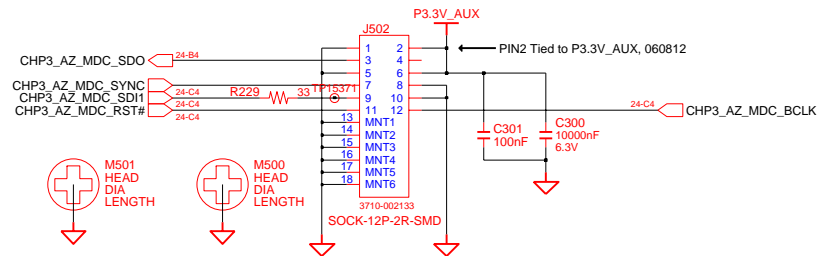

USB Port

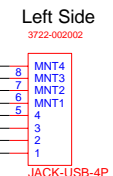
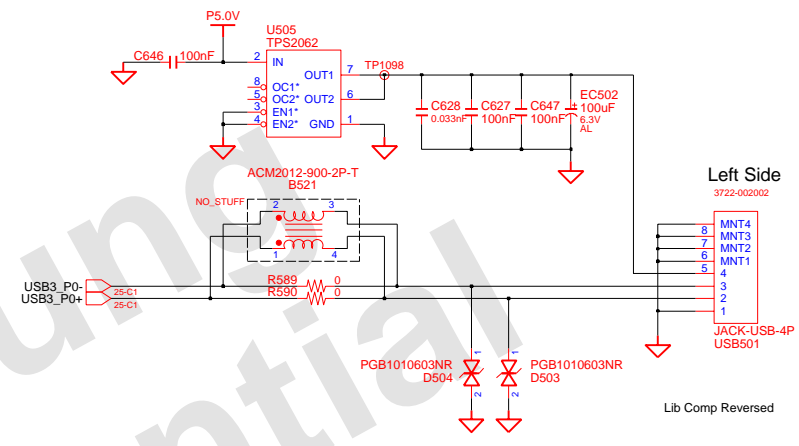

BLUETOOTH

Bluetooth 2.0 Standard

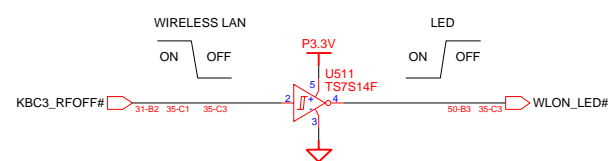
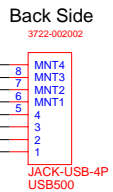
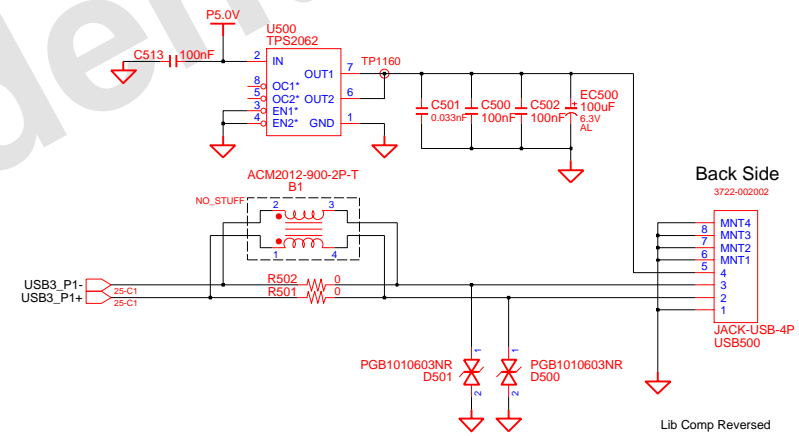
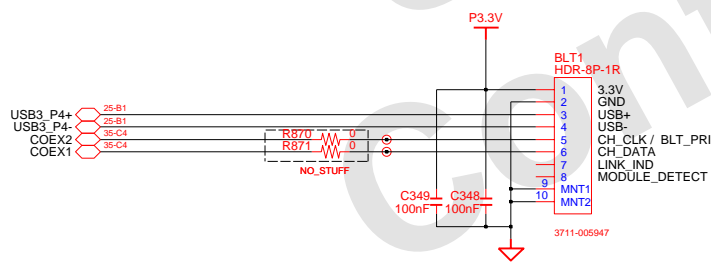

DRAW	ZHOU JUN	DATE	4/10/2007	TITLE	TORINO 2	SAMSUNG ELECTRONICS
CHECK	GUO LEI	DEV. STEP	MP	MAIN	PART NO.	
APPROVAL	KEVIN LEE	REV	1,1	USB,MDC & BLUETOOTH	BA41-00727/8A	
MODULE CODE		LAST EDIT				
				March 28, 2007 3:33:29 PM	PAGE 34	OF 54

SAMSUNG PROPRIETARY
 THIS DOCUMENT CONTAINS CONFIDENTIAL
 PROPRIETARY INFORMATION THAT IS
 SAMSUNG ELECTRONICS CO'S PROPERTY.
 DO NOT DISCLOSE TO OR DUPLICATE FOR OTHERS
 EXCEPT AS AUTHORIZED BY SAMSUNG.

Mini PCI-E Card (WLAN)

Mini PCI-E Card (HSDPA)

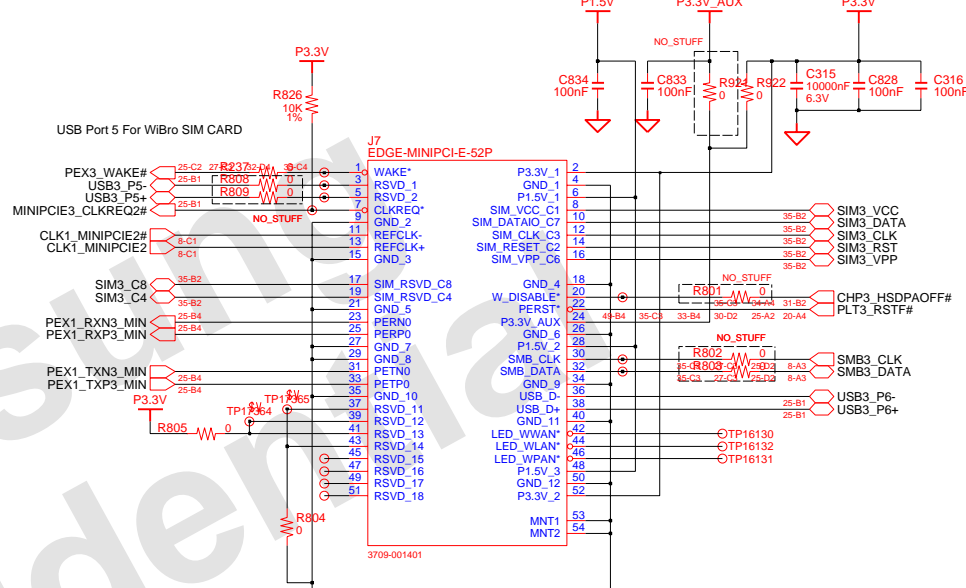
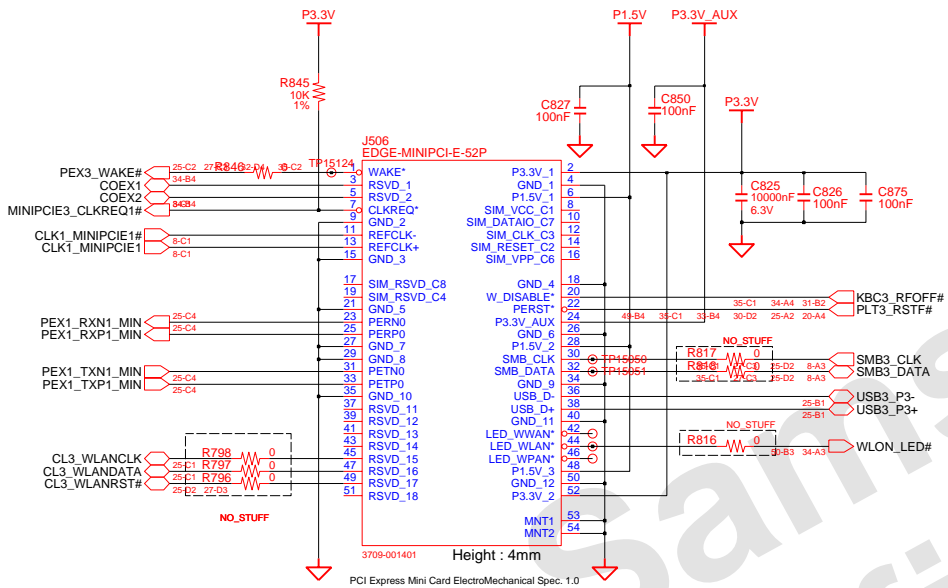

SIM Card FFC CONN

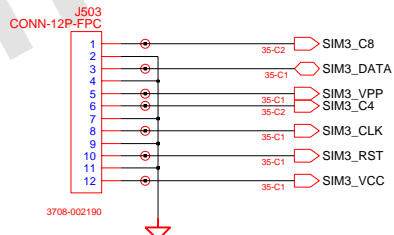

PEM

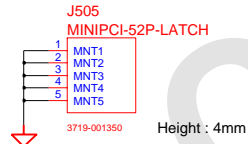
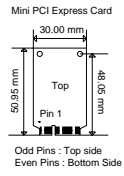

DRAW	ZHOU JUN	DATE	4/10/2007	TITLE	TORINO 2	SAMSUNG ELECTRONICS
CHECK	GUO LEI	DEV. STEP	MP	MAIN	MAIN	
APPROVAL	KEVIN LEE	REV	1.1	MINI CARD	MINI CARD	PART NO. BA41-00727/8A
MODULE CODE		LAST EDIT				
March 28, 2007 3:33:29 PM						PAGE 35 OF 54

SAMSUNG PROPRIETARY
 THIS DOCUMENT CONTAINS CONFIDENTIAL
 PROPRIETARY INFORMATION THAT IS
 SAMSUNG ELECTRONICS CO'S PROPERTY.
 DO NOT DISCLOSE TO OR DUPLICATE FOR OTHERS
 EXCEPT AS AUTHORIZED BY SAMSUNG.

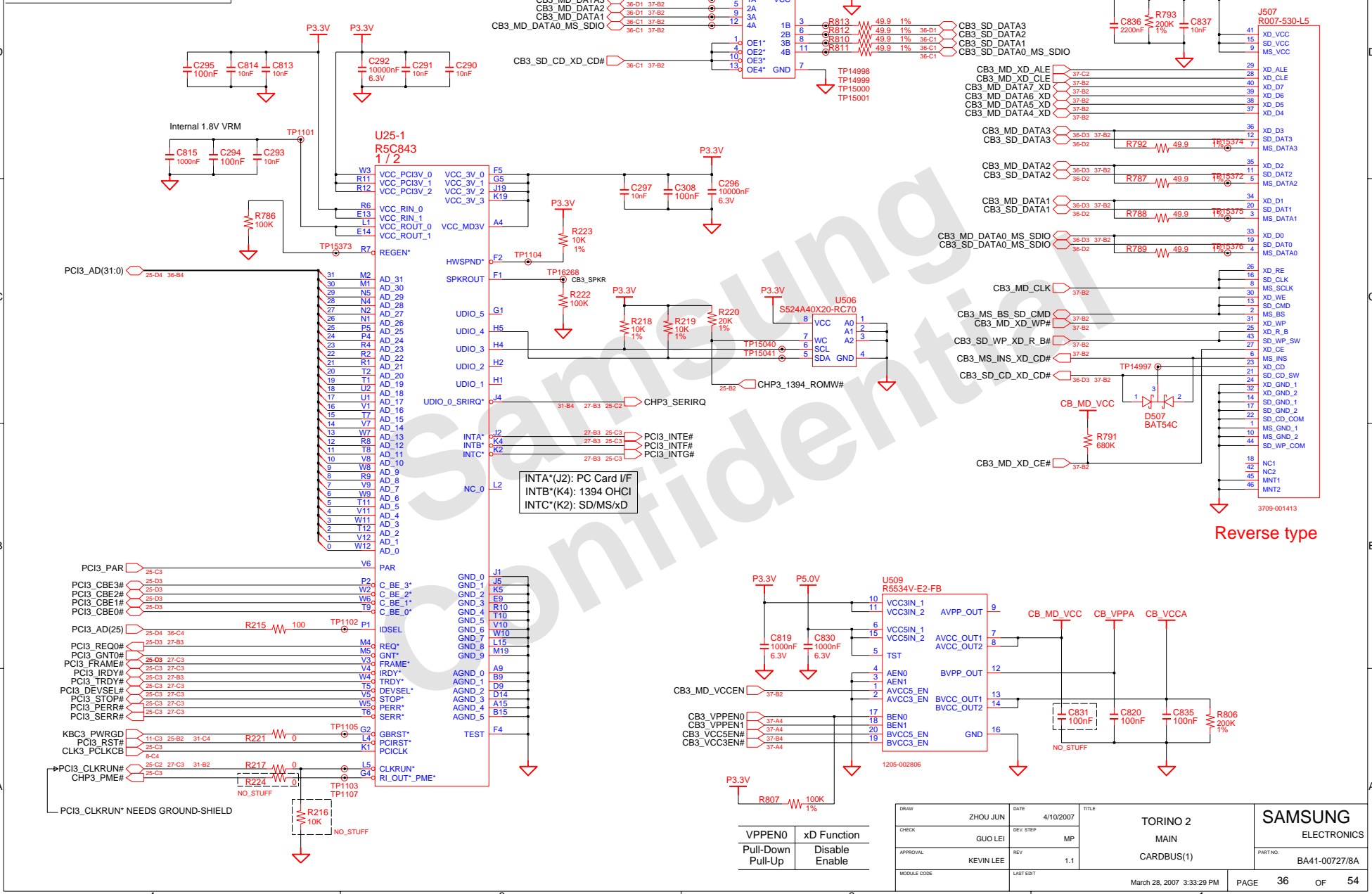

INTA*(J2): PC Card I/F
 INTB*(K4): 1394 OHCI
 INTC*(K2): SD/MS/xD

Reverse type

<table border="1"> <tr> <td>VPPEN0</td> <td>xD Function</td> </tr> <tr> <td>Pull-Down</td> <td>Disable</td> </tr> <tr> <td>Pull-Up</td> <td>Enable</td> </tr> </table>	VPPEN0	xD Function	Pull-Down	Disable	Pull-Up	Enable	<table border="1"> <tr> <td>DRAW</td> <td>ZHOU JUN</td> <td>DATE</td> <td>4/10/2007</td> <td>TITLE</td> <td>TORINO 2</td> </tr> <tr> <td>CHECK</td> <td>GUO LEI</td> <td>DEV_STEP</td> <td>MP</td> <td></td> <td>MAIN</td> </tr> <tr> <td>APPROVAL</td> <td>KEVIN LEE</td> <td>REV</td> <td>1.1</td> <td></td> <td>CARDBUS(1)</td> </tr> <tr> <td>MODULE CODE</td> <td></td> <td>LAST EDIT</td> <td></td> <td></td> <td></td> </tr> </table>	DRAW	ZHOU JUN	DATE	4/10/2007	TITLE	TORINO 2	CHECK	GUO LEI	DEV_STEP	MP		MAIN	APPROVAL	KEVIN LEE	REV	1.1		CARDBUS(1)	MODULE CODE		LAST EDIT				<table border="1"> <tr> <td colspan="2">SAMSUNG</td> </tr> <tr> <td colspan="2">ELECTRONICS</td> </tr> <tr> <td>PART NO.</td> <td>BA41-00727/8A</td> </tr> </table>	SAMSUNG		ELECTRONICS		PART NO.	BA41-00727/8A
VPPEN0	xD Function																																					
Pull-Down	Disable																																					
Pull-Up	Enable																																					
DRAW	ZHOU JUN	DATE	4/10/2007	TITLE	TORINO 2																																	
CHECK	GUO LEI	DEV_STEP	MP		MAIN																																	
APPROVAL	KEVIN LEE	REV	1.1		CARDBUS(1)																																	
MODULE CODE		LAST EDIT																																				
SAMSUNG																																						
ELECTRONICS																																						
PART NO.	BA41-00727/8A																																					
March 28, 2007 3:33:29 PM				PAGE	36	OF	54																															

SAMSUNG PROPRIETARY
 THIS DOCUMENT CONTAINS CONFIDENTIAL
 PROPRIETARY INFORMATION THAT IS
 SAMSUNG ELECTRONICS CO'S PROPERTY.
 DO NOT DISCLOSE TO OR DUPLICATE FOR OTHERS
 EXCEPT AS AUTHORIZED BY SAMSUNG.

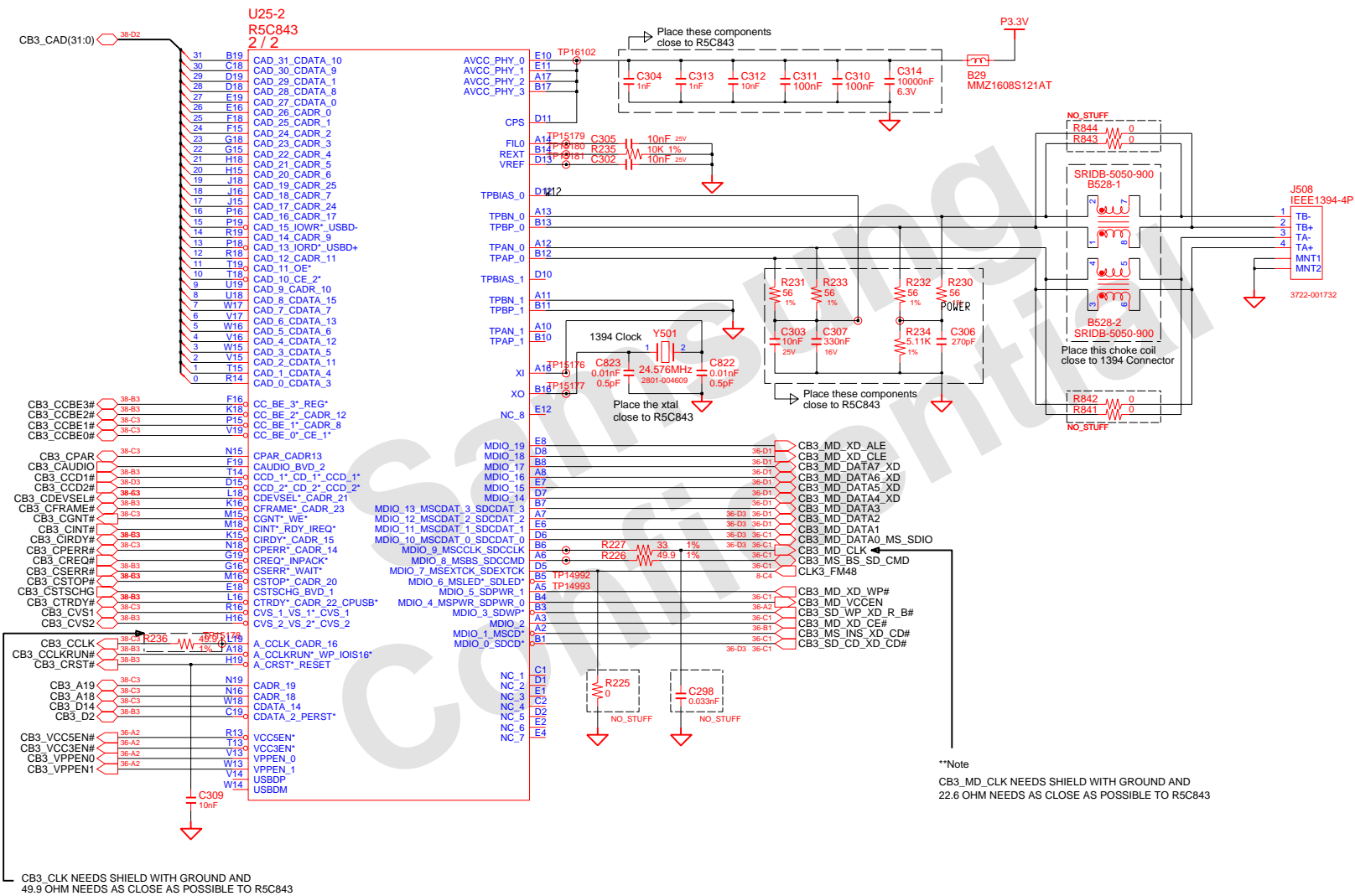

**Note
 CB3_MD_CLK NEEDS SHIELD WITH GROUND AND
 22.6 OHM NEEDS AS CLOSE AS POSSIBLE TO R5C843

DRAW	ZHOU JUN	DATE	4/10/2007	TITLE	TORINO 2 MAIN CARDBUS(2)	SAMSUNG ELECTRONICS
CHECK	GUO LEI	DEV_STEP	MP			
APPROVAL	KEVIN LEE	REV	1.1			PART NO. BA41-00727/8A
MODULE CODE		LAST ENT				
				March 28, 2007 3:33:29 PM	PAGE	37 OF 54

SAMSUNG PROPRIETARY
 THIS DOCUMENT CONTAINS CONFIDENTIAL
 PROPRIETARY INFORMATION THAT IS
 SAMSUNG ELECTRONICS CO'S PROPERTY.
 DO NOT DISCLOSE TO OR DUPLICATE FOR OTHERS
 EXCEPT AS AUTHORIZED BY SAMSUNG.

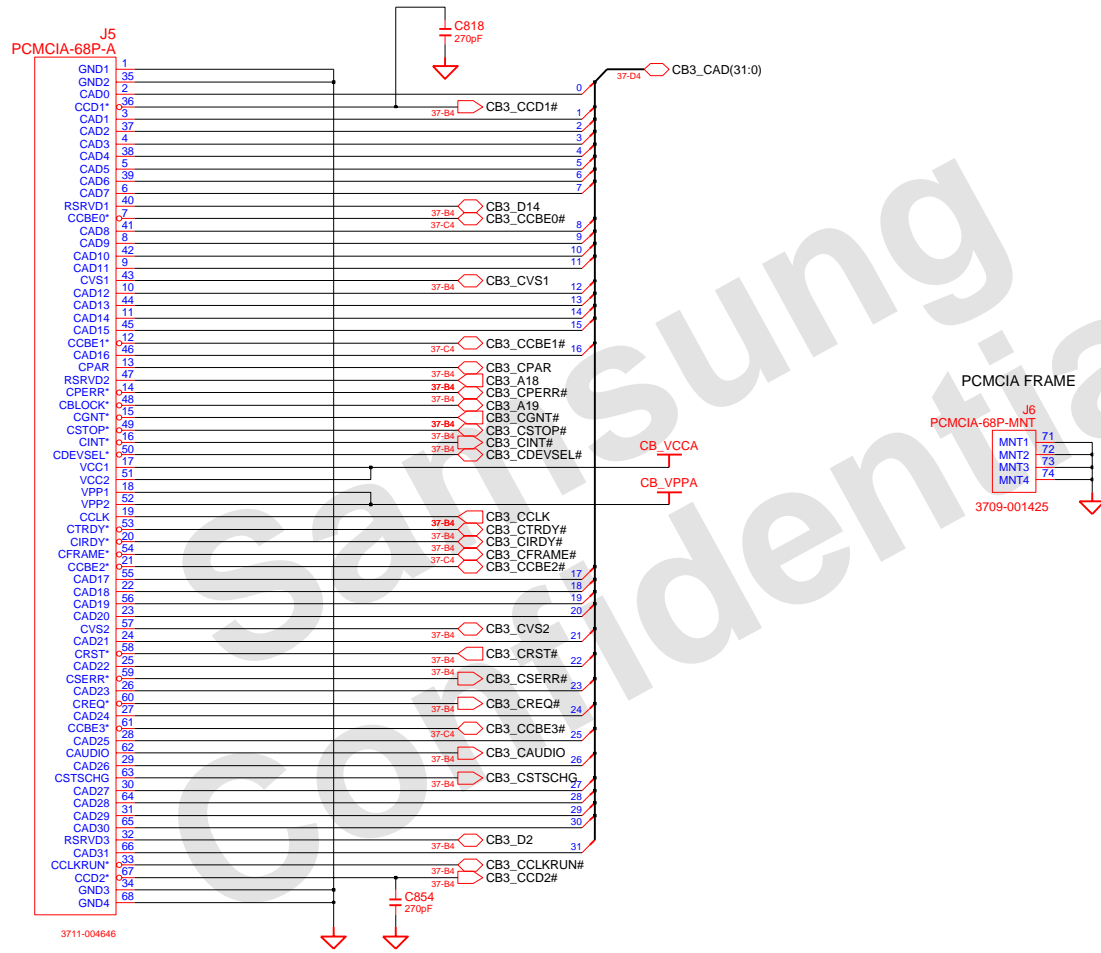

DRAW	ZHOU JUN	DATE	4/10/2007	TITLE	TORINO 2	SAMSUNG ELECTRONICS
CHECK	GUO LEI	DEV STEP	MP	MAIN	MAIN	
APPROVAL	KEVIN LEE	REV	1,1	CARBUS (3)	PART NO.	BA41-00727/8A
MODULE CODE		LAST EDIT		March 28, 2007 3:33:29 PM	PAGE	38 OF 54

SAMSUNG PROPRIETARY
 THIS DOCUMENT CONTAINS CONFIDENTIAL
 PROPRIETARY INFORMATION THAT IS
 SAMSUNG ELECTRONICS CO'S PROPERTY.
 DO NOT DISCLOSE TO OR DUPLICATE FOR OTHERS
 EXCEPT AS AUTHORIZED BY SAMSUNG.

AUDIO CODEC

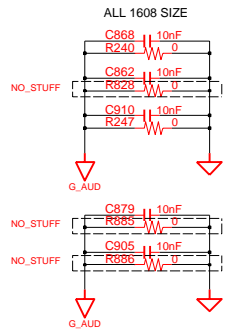
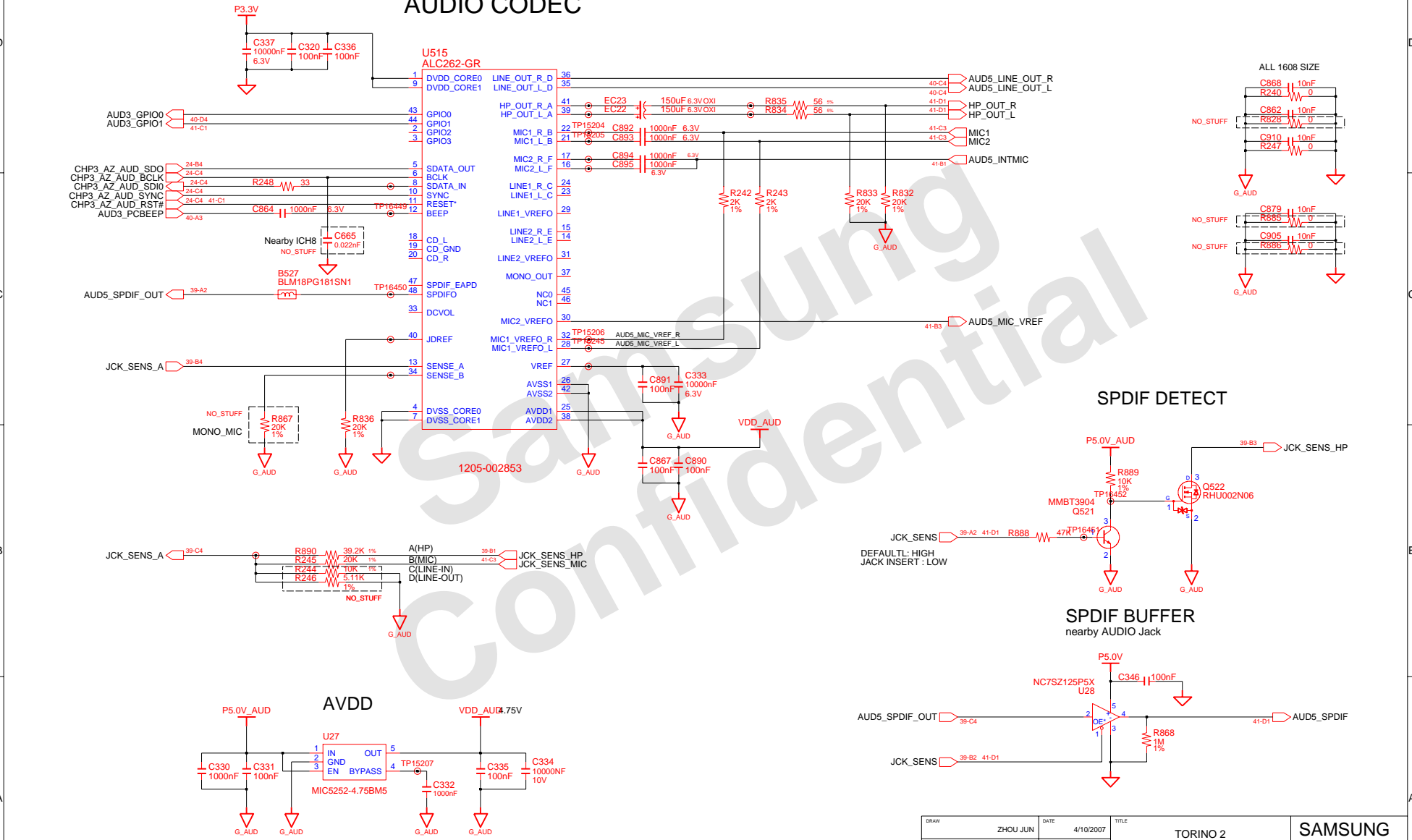

SPIDF DETECT

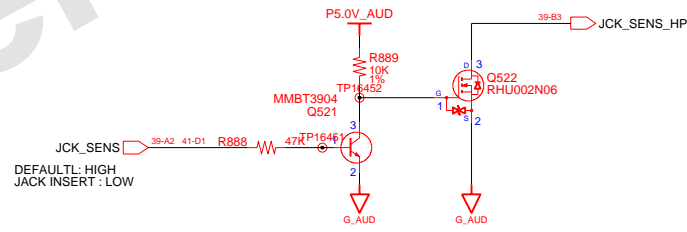

SPIDF BUFFER nearby AUDIO Jack

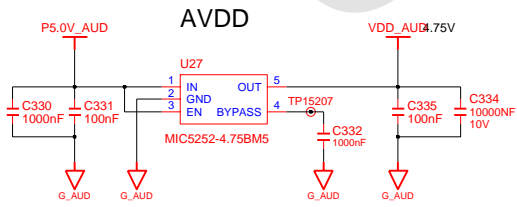
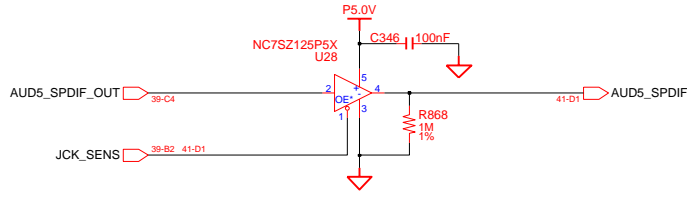

DRAW	ZHOU JUN	DATE	4/10/2007	TITLE	TORINO 2	SAMSUNG ELECTRONICS
CHECK	GUO LEI	DEV. STEP	MP	MAIN	BA41-00727/8A	
APPROVAL	KEVIN LEE	REV	1.1	AUDIO CODEC	PART NO.	BA41-00727/8A
MODULE CODE		LAST EDIT				
				March 28, 2007 3:33:29 PM	PAGE	39 OF 54

SAMSUNG PROPRIETARY
 THIS DOCUMENT CONTAINS CONFIDENTIAL
 PROPRIETARY INFORMATION THAT IS
 SAMSUNG ELECTRONICS CO'S PROPERTY.
 DO NOT DISCLOSE TO OR DUPLICATE FOR OTHERS
 EXCEPT AS AUTHORIZED BY SAMSUNG.

AUDIO AMP

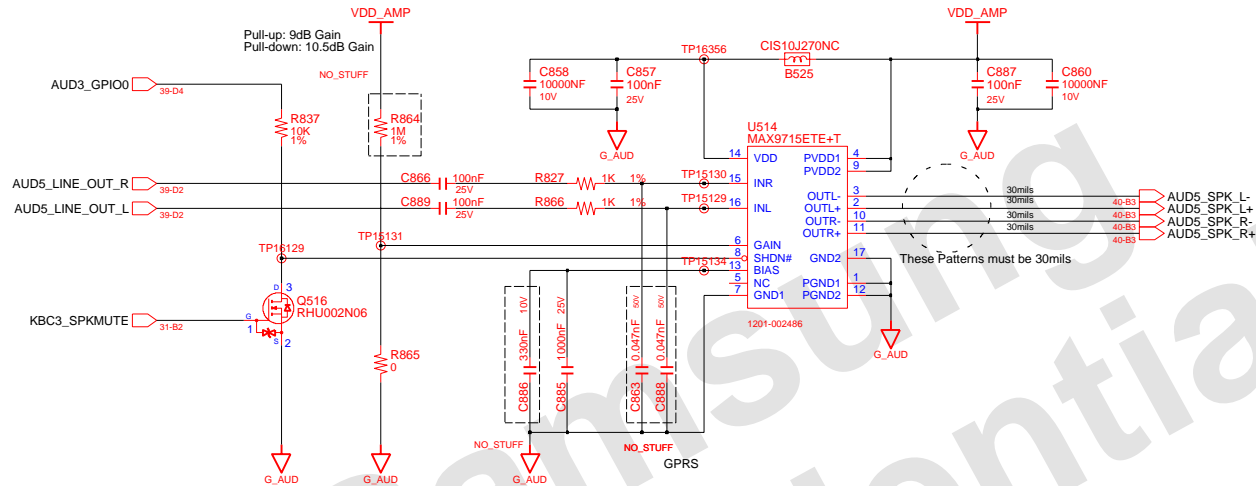

INTERNAL STEREO SPEAKERS

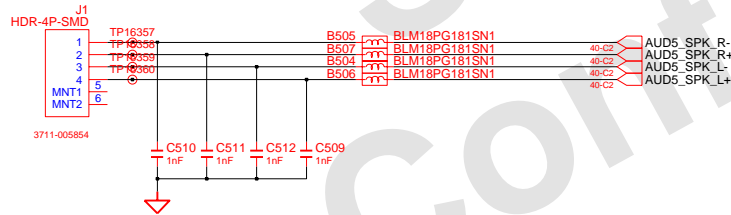

PC BEEP

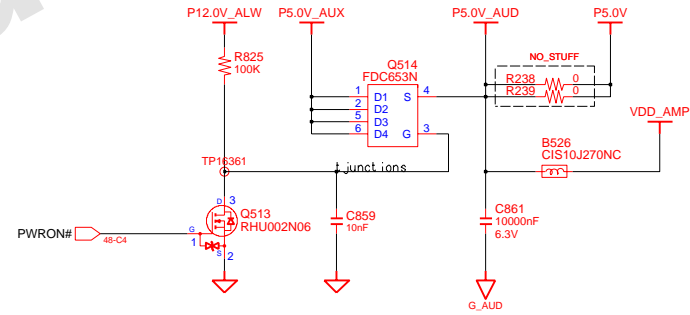
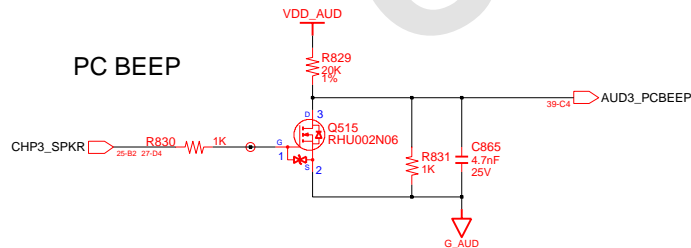

DRAW	ZHOU JUN	DATE	4/10/2007	TITLE	TORINO 2	SAMSUNG
CHECK	GUO LEI	DEV. STEP	MP		MAIN	ELECTRONICS
APPROVAL	KEVIN LEE	REV	1,1		AUDIO AMPLIFIER	PART NO.
MODULE CODE		LAST ENT				BA41-00727/8A
				March 28, 2007 3:33:29 PM	PAGE	40 OF 54

SAMSUNG PROPRIETARY
 THIS DOCUMENT CONTAINS CONFIDENTIAL
 PROPRIETARY INFORMATION THAT IS
 SAMSUNG ELECTRONICS CO'S PROPERTY.
 DO NOT DISCLOSE TO OR DUPLICATE FOR OTHERS
 EXCEPT AS AUTHORIZED BY SAMSUNG.

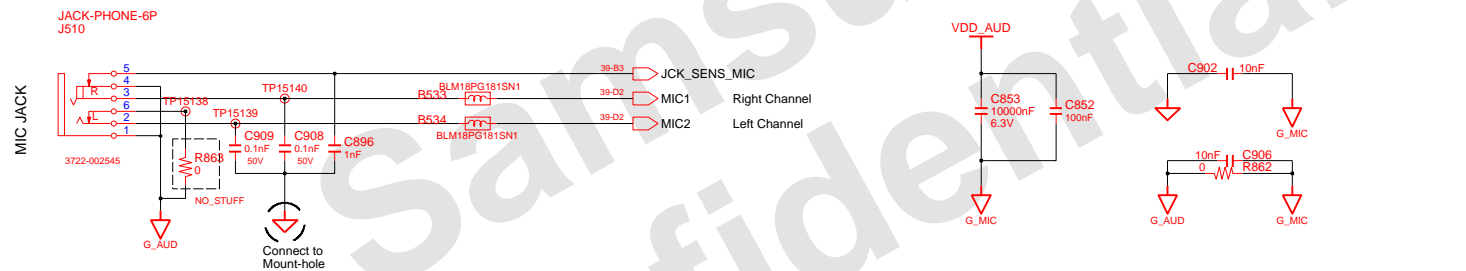
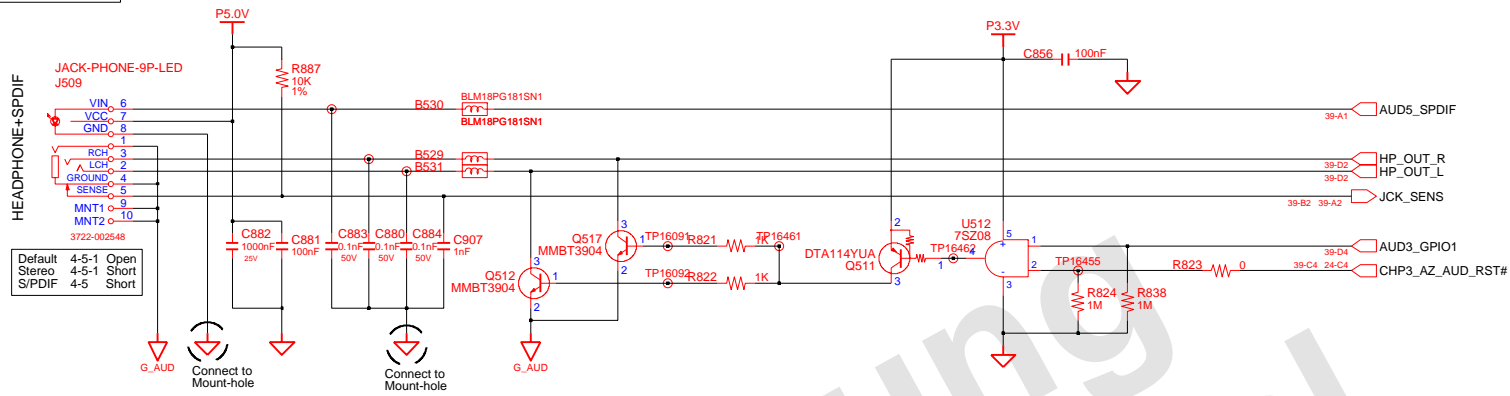

Internal MIC

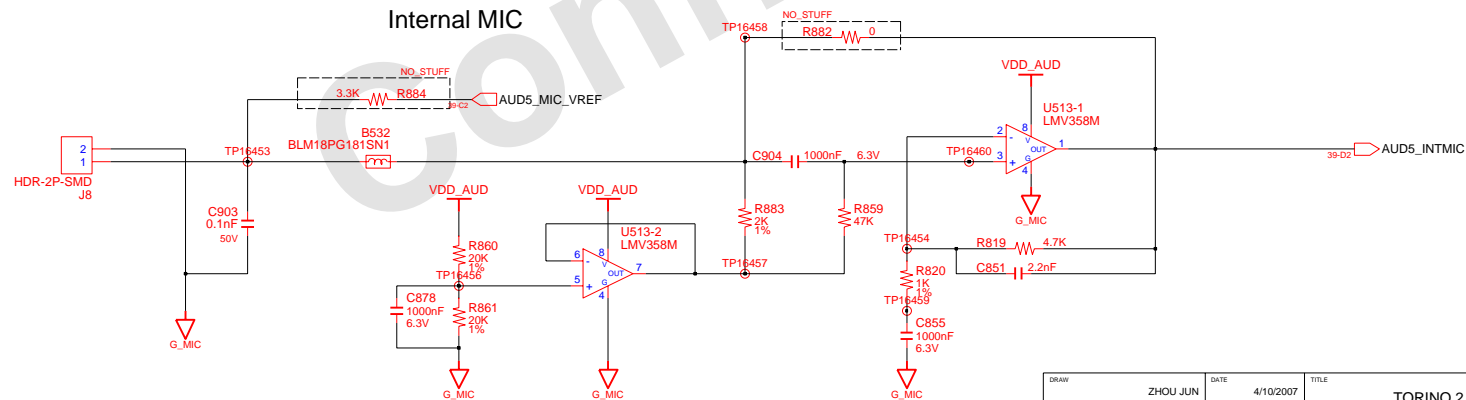

DRAW	ZHOU JUN	DATE	4/10/2007	TITLE	TORINO 2	SAMSUNG ELECTRONICS
CHECK	GUO LEI	DEV. STEP	MP	MAIN	MAIN	
APPROVAL	KEVIN LEE	REV	1,1	AUDIO JACK	PART NO. BA41-00727/8A	
MODULE CODE		LAST EDIT			March 28, 2007 3:33:29 PM	PAGE 41 OF 54

SAMSUNG PROPRIETARY
 THIS DOCUMENT CONTAINS CONFIDENTIAL
 PROPRIETARY INFORMATION THAT IS
 SAMSUNG ELECTRONICS CO'S PROPERTY.
 DO NOT DISCLOSE TO OR DUPLICATE FOR OTHERS
 EXCEPT AS AUTHORIZED BY SAMSUNG.

CHARGER & POWER MANAGEMENT

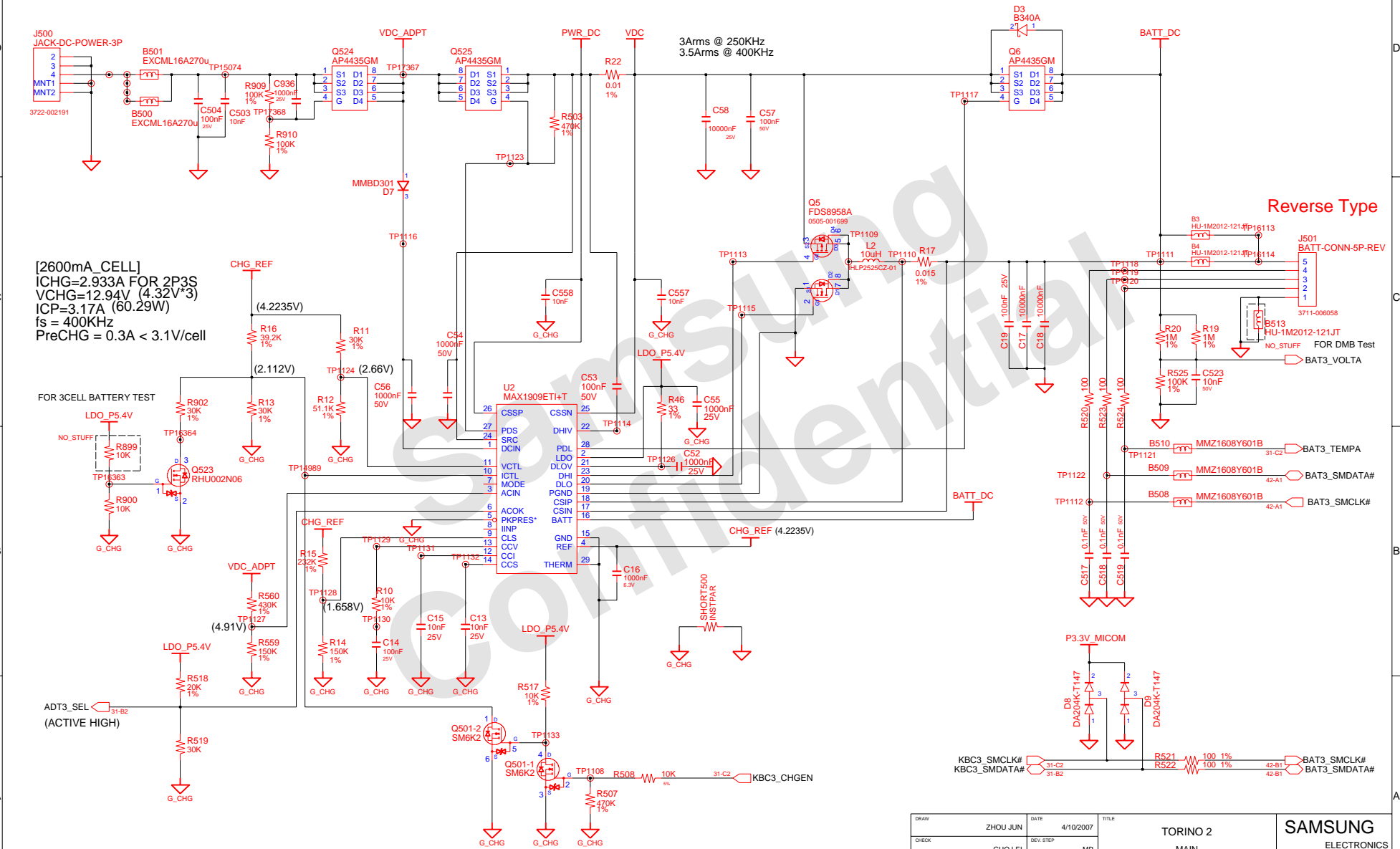

DRAW	DATE	TITLE	SAMSUNG	
ZHOU JUN	4/10/2007	TORINO 2	ELECTRONICS	
CHECK	DEV_STEP	MAIN	PART NO. BA41-00727/8A	
APPROVAL	REV	VDC & CHARGER	PAGE 42 OF 54	
MODULE CODE	LAST ENT	March 28, 2007 3:33:29 PM	D:\users\mentor\Torino2\MP12_MP1.1_0410	

SAMSUNG PROPRIETARY
 THIS DOCUMENT CONTAINS CONFIDENTIAL
 PROPRIETARY INFORMATION THAT IS
 SAMSUNG ELECTRONICS CO'S PROPERTY.
 DO NOT DISCLOSE TO OR DUPLICATE FOR OTHERS
 EXCEPT AS AUTHORIZED BY SAMSUNG.

P5V_AUX & P3.3V_AUX

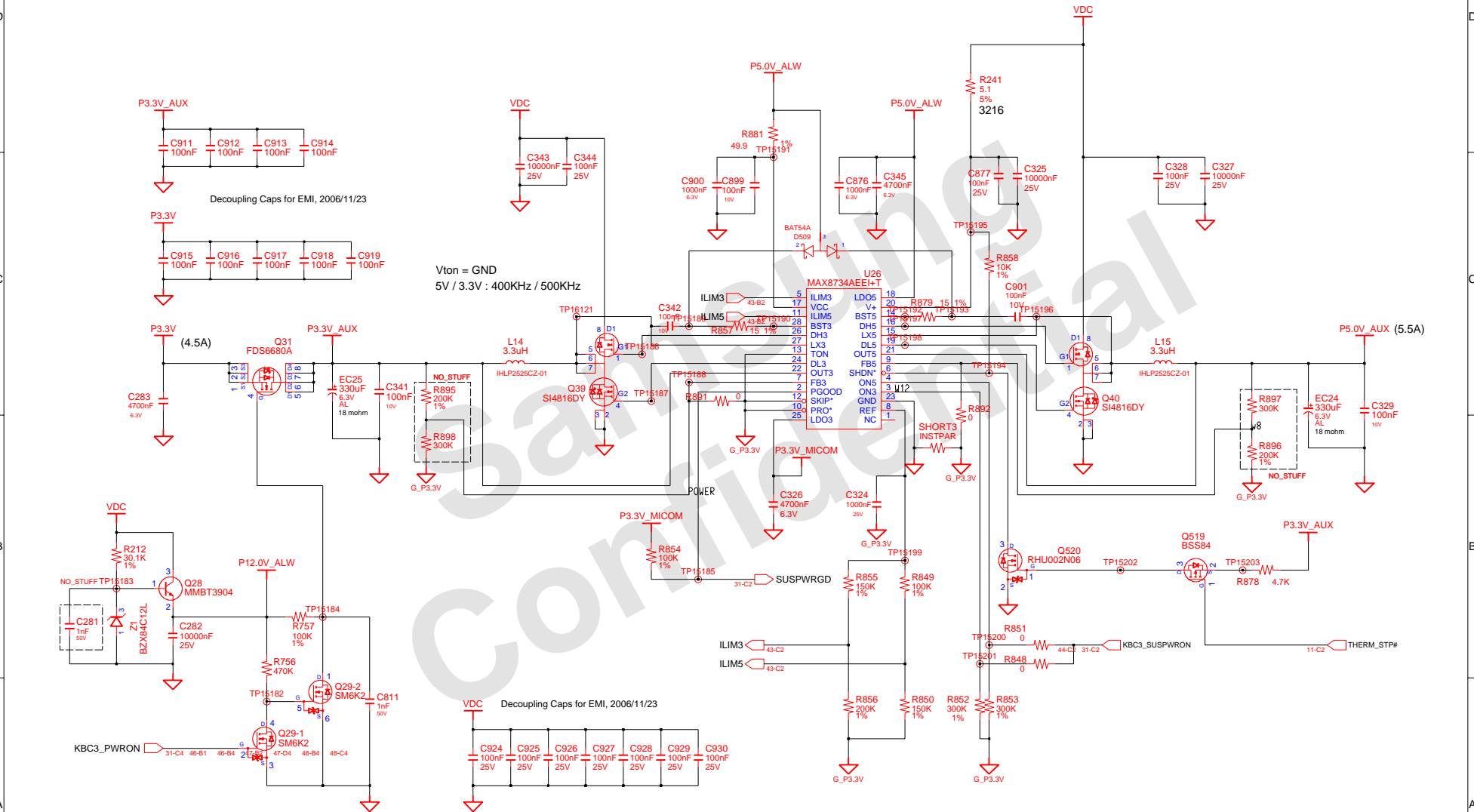

DRAW	ZHOU JUN	DATE	4/10/2007	TITLE	TORINO 2	SAMSUNG ELECTRONICS
CHECK	GUO LEI	DEV. STEP	MP	MAIN	MAIN	
APPROVAL	KEVIN LEE	REV	1,1	P5V_AUX & P3.3V_LAN(AUX)		PART NO. BA41-00727/8A
MODULE CODE		LAST EDIT		March 28, 2007 3:33:29 PM	PAGE	43 OF 54

SAMSUNG PROPRIETARY
 THIS DOCUMENT CONTAINS CONFIDENTIAL
 PROPRIETARY INFORMATION THAT IS
 SAMSUNG ELECTRONICS CO'S PROPERTY.
 DO NOT DISCLOSE TO OR DUPLICATE FOR OTHERS
 EXCEPT AS AUTHORIZED BY SAMSUNG.

DDR2 POWER

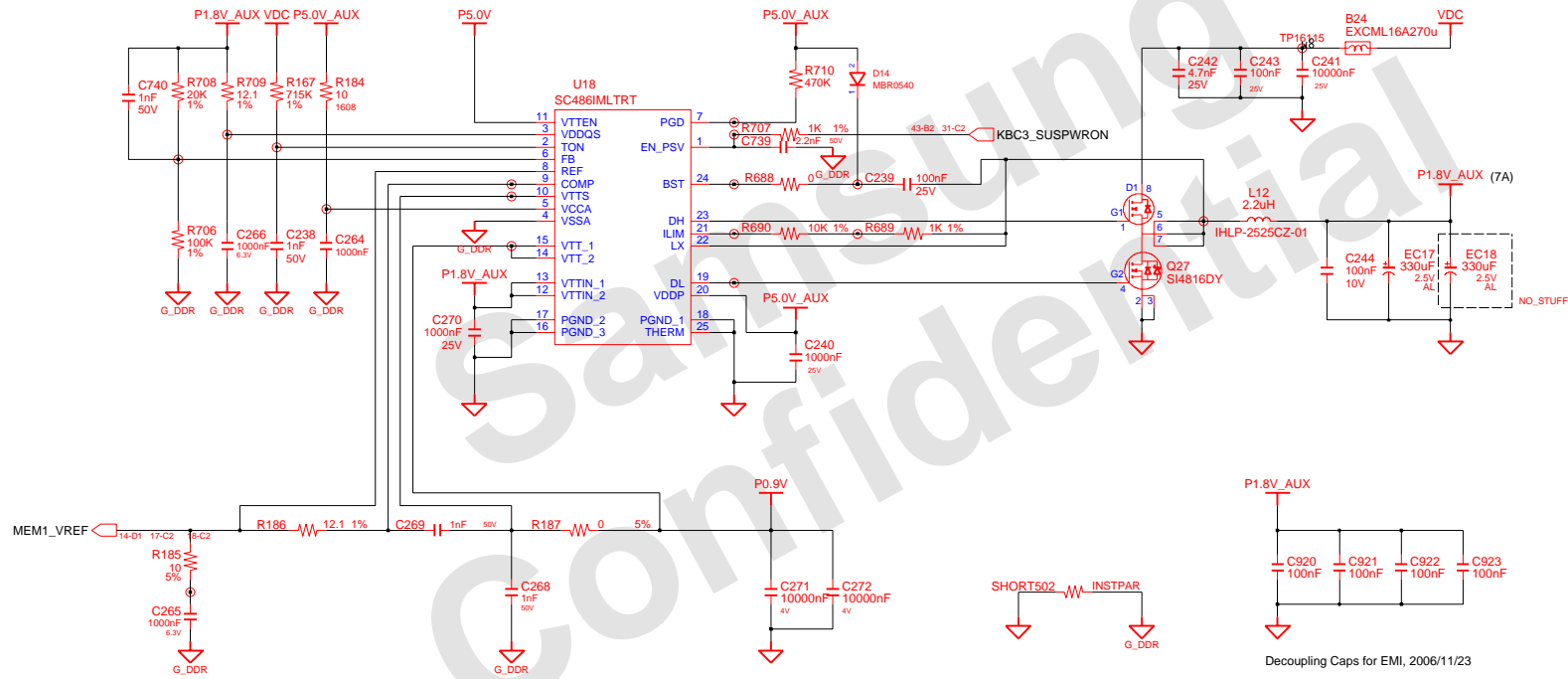

DRAW	ZHOU JUN	DATE	4/10/2007	TITLE	TORINO 2 MAIN DDR2 POWER	SAMSUNG ELECTRONICS PART NO. BA41-00727/8A
CHECK	GUO LEI	DEV. STEP	MP			
APPROVAL	KEVIN LEE	REV	1,1			
MODULE CODE		LAST EDIT				
			March 28, 2007 3:33:29 PM	PAGE	44	OF 54

SAMSUNG PROPRIETARY
 THIS DOCUMENT CONTAINS CONFIDENTIAL
 PROPRIETARY INFORMATION THAT IS
 SAMSUNG ELECTRONICS CO'S PROPERTY.
 DO NOT DISCLOSE TO OR DUPLICATE FOR OTHERS
 EXCEPT AS AUTHORIZED BY SAMSUNG.

CPU VRM [SEMTECH]

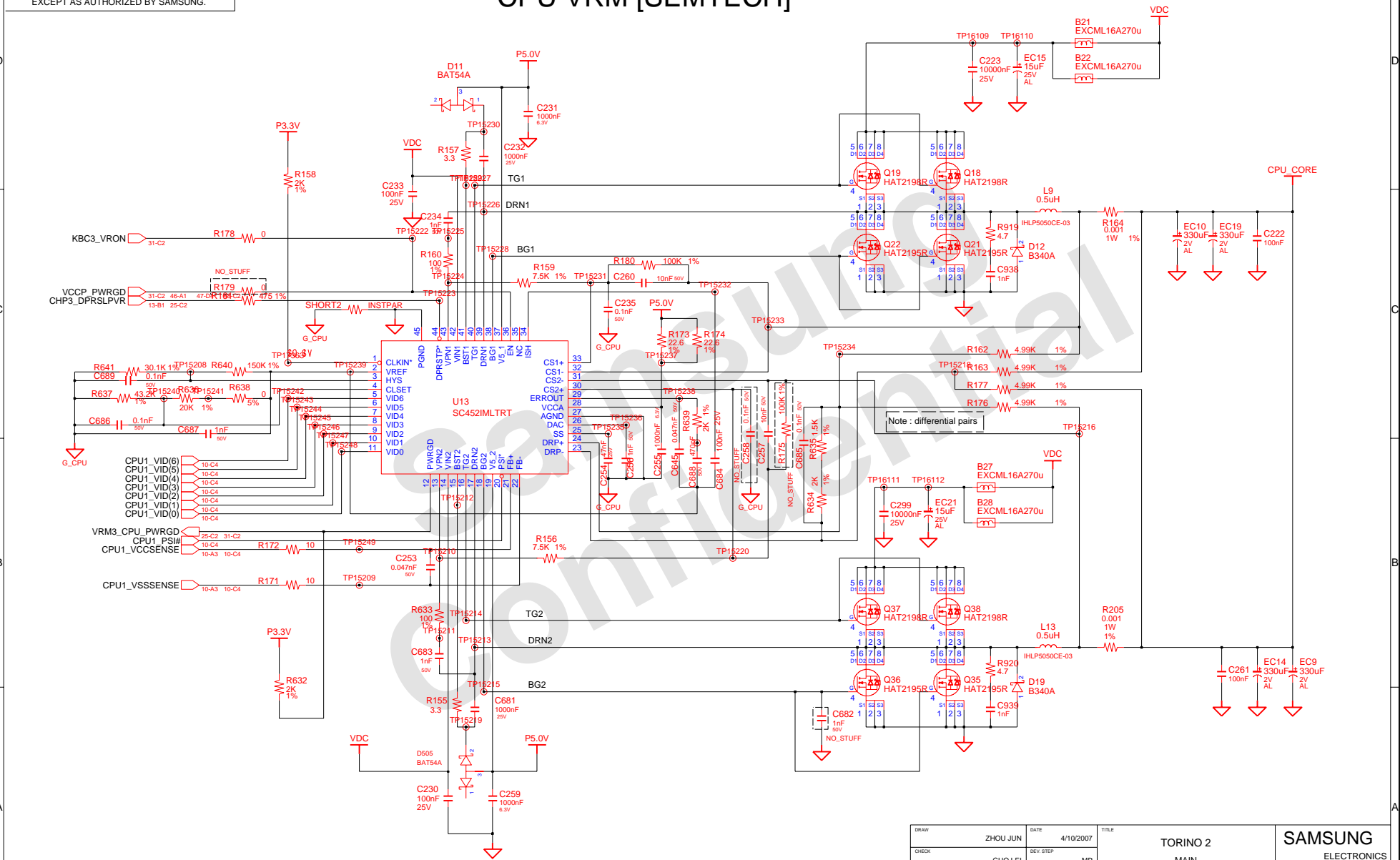

DRAW	ZHOU JUN	DATE	4/10/2007	TITLE	TORINO 2 MAIN CPU VRM	SAMSUNG ELECTRONICS PART NO. BA41-00727/8A
CHECK	GUO LEI	DEV. STEP	MP			
APPROVAL	KEVIN LEE	REV	1.1			
MODULE CODE		LAST ENT				
March 28, 2007 3:33:29 PM				PAGE	45 OF 54	

SAMSUNG PROPRIETARY
 THIS DOCUMENT CONTAINS CONFIDENTIAL
 PROPRIETARY INFORMATION THAT IS
 SAMSUNG ELECTRONICS CO'S PROPERTY.
 DO NOT DISCLOSE TO OR DUPLICATE FOR OTHERS
 EXCEPT AS AUTHORIZED BY SAMSUNG.

P1.25V & P1.05V

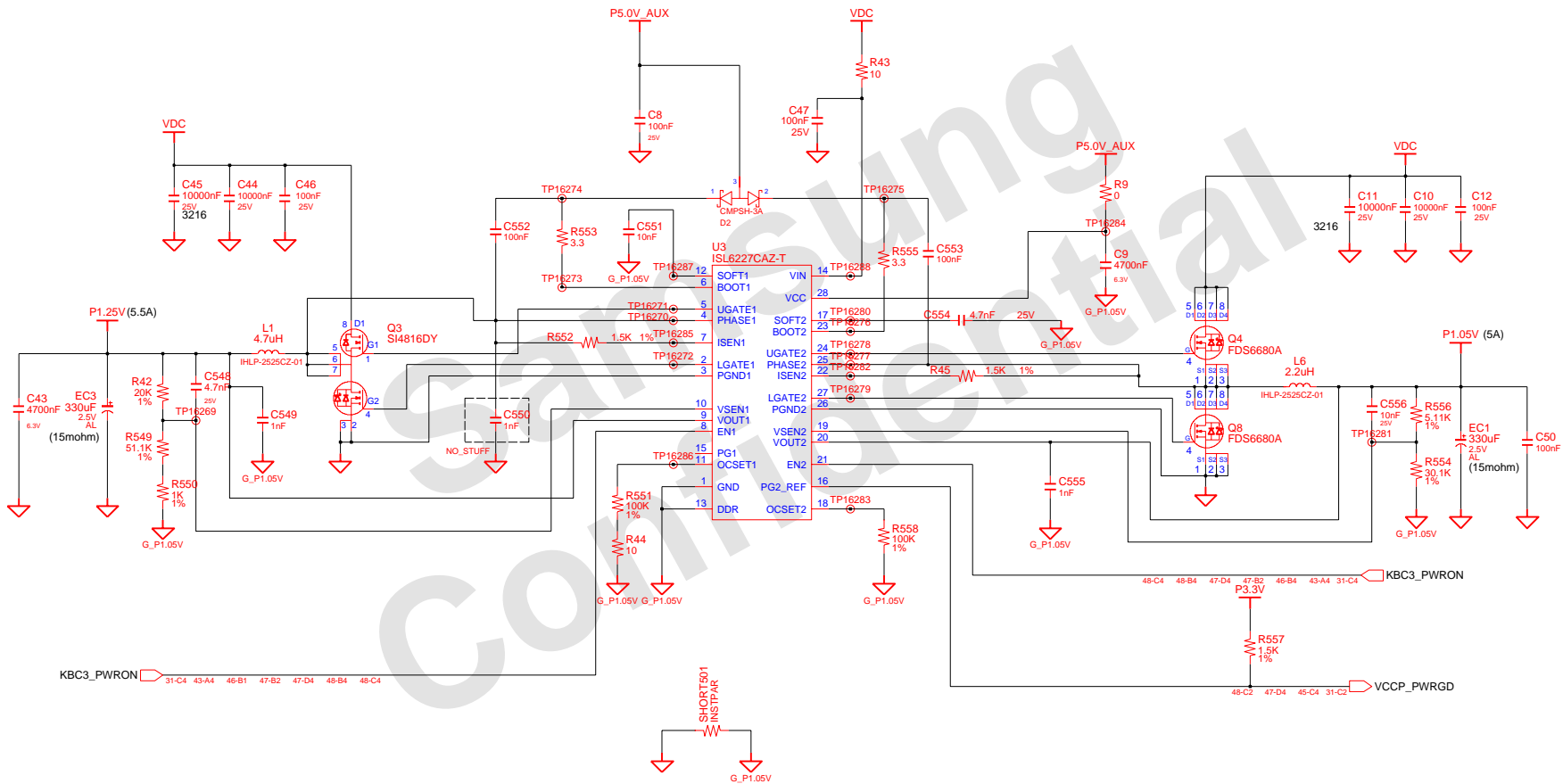

DRAW	ZHOU JUN	DATE	4/10/2007	TITLE	TORINO 2	SAMSUNG ELECTRONICS
CHECK	GUO LEI	DEV. STEP	MP		MAIN	
APPROVAL	KEVIN LEE	REV	1,1		P1.25V & P1.05V	PART NO. BA41-00727/8A
MODULE CODE		LAST EDIT		March 28, 2007 3:33:29 PM	PAGE	46 OF 54

SAMSUNG PROPRIETARY
 THIS DOCUMENT CONTAINS CONFIDENTIAL
 PROPRIETARY INFORMATION THAT IS
 SAMSUNG ELECTRONICS CO'S PROPERTY.
 DO NOT DISCLOSE TO OR DUPLICATE FOR OTHERS
 EXCEPT AS AUTHORIZED BY SAMSUNG.

Graphic Core Power

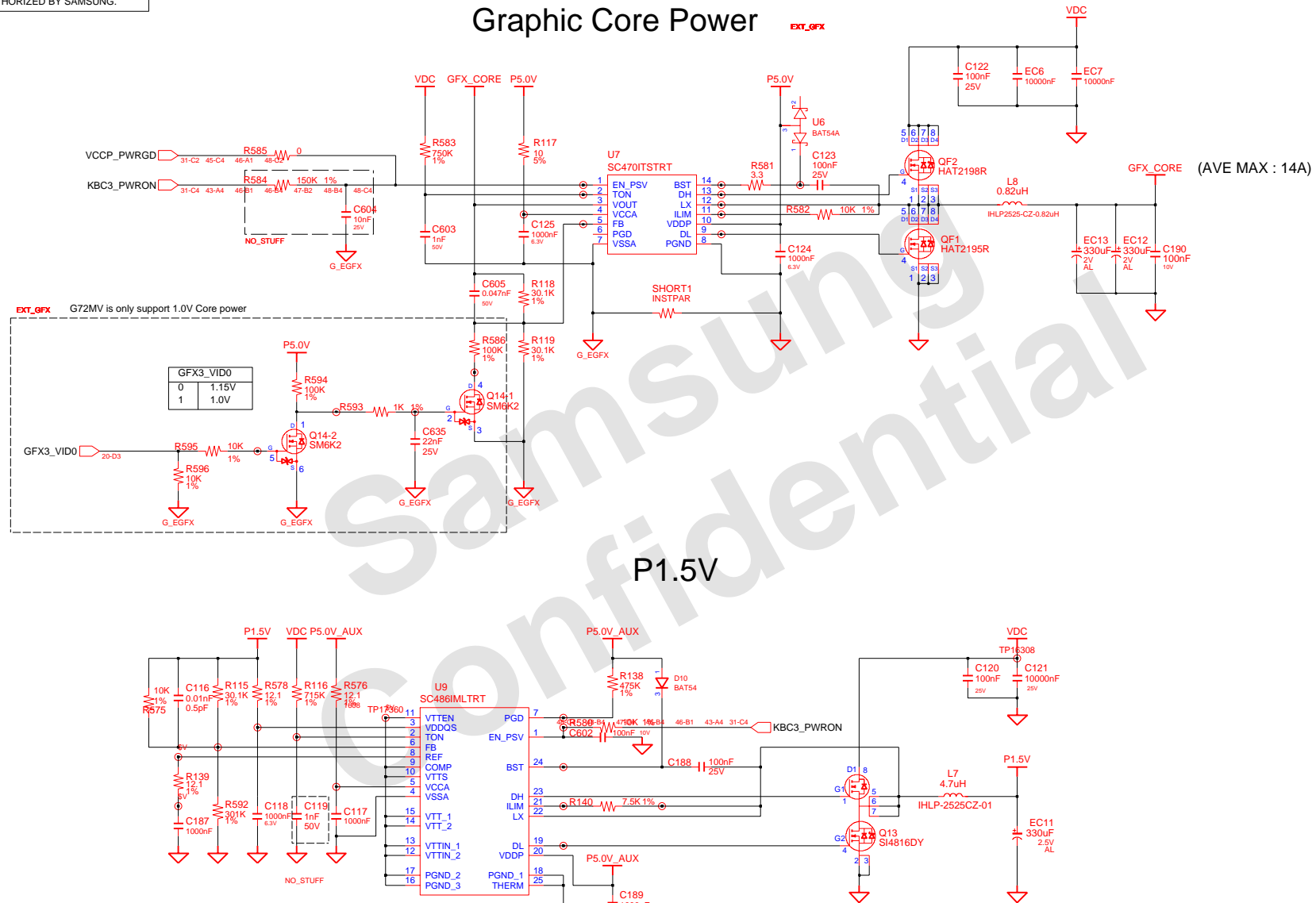

P1.5V

DRAW	ZHOU JUN	DATE	4/10/2007	TITLE	TORINO 2 MAIN GFX_CORE & P1.5V	SAMSUNG ELECTRONICS
CHECK	GUO LEI	DEV. STEP	MP		PART NO. BA41-00727/8A	
APPROVAL	KEVIN LEE	REV	1,1			
MODULE CODE		LAST ENT				
				March 28, 2007 3:33:29 PM	PAGE	47 OF 54

SAMSUNG PROPRIETARY
 THIS DOCUMENT CONTAINS CONFIDENTIAL
 PROPRIETARY INFORMATION THAT IS
 SAMSUNG ELECTRONICS CO'S PROPERTY.
 DO NOT DISCLOSE TO OR DUPLICATE FOR OTHERS
 EXCEPT AS AUTHORIZED BY SAMSUNG.

Switched Power On (P5.0V)

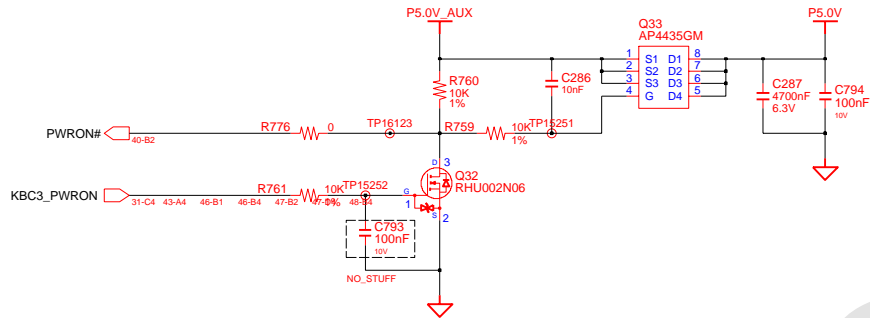

Switched Power On (P1.8V)

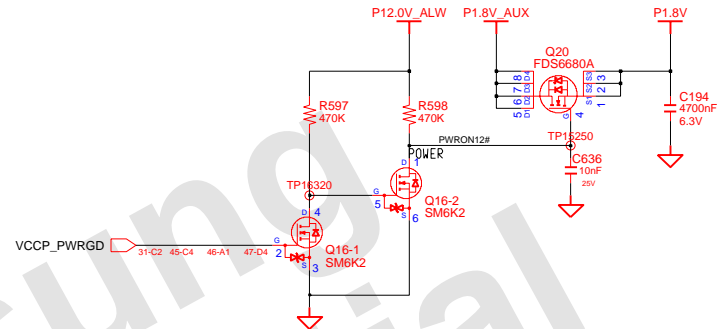

Switched Power On (P2.5V)

NO_STUFF
 It's only used for G72M

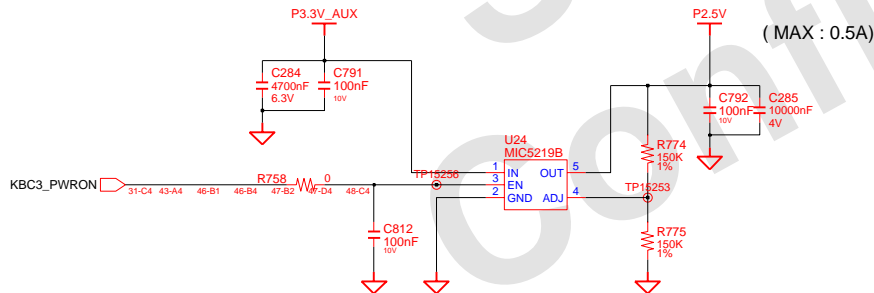

Switched Power On (P1.2V)

EXT_GFX

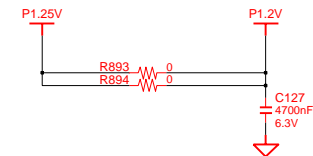

DRAW	ZHOU JUN	DATE	4/10/2007	TITLE	TORINO 2 MAIN SWITCHED POWER	SAMSUNG ELECTRONICS
CHECK	GUO LEI	DEV. STEP	MP			
APPROVAL	KEVIN LEE	REV	1,1			PART NO. BA41-00727/8A
MODULE CODE		LAST EDIT	March 28, 2007 3:33:29 PM	PAGE	48	OF 54

SAMSUNG PROPRIETARY
 THIS DOCUMENT CONTAINS CONFIDENTIAL
 PROPRIETARY INFORMATION THAT IS
 SAMSUNG ELECTRONICS CO'S PROPERTY.
 DO NOT DISCLOSE TO OR DUPLICATE FOR OTHERS
 EXCEPT AS AUTHORIZED BY SAMSUNG.

OPTION: DMB INTERFACE

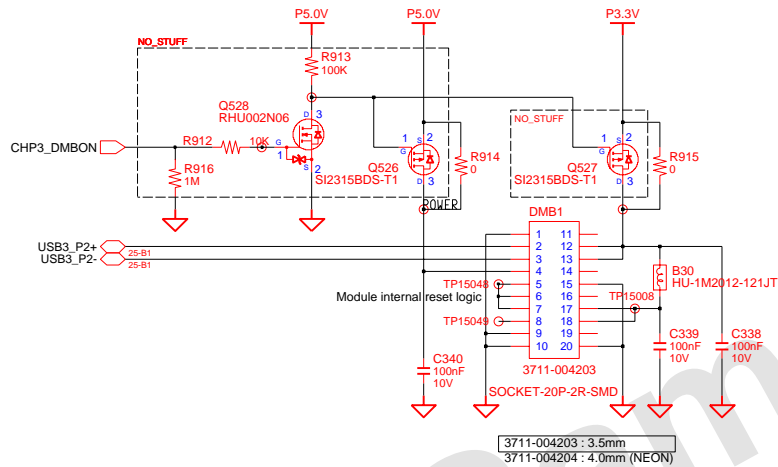

Power Switch Connector

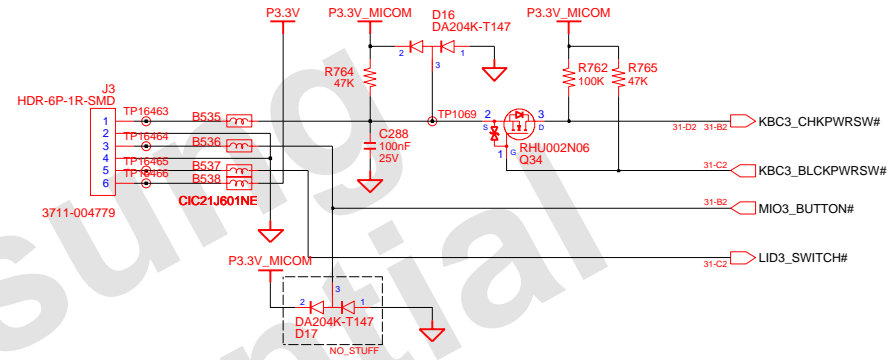

KEYBOARD

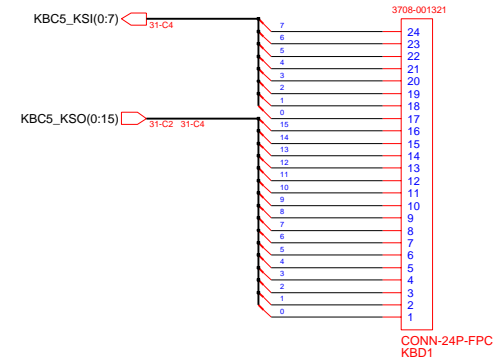
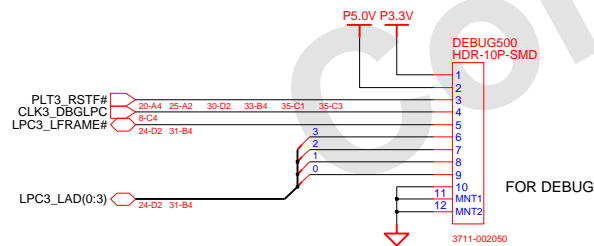

DRAW	ZHOU JUN	DATE	4/10/2007	TITLE	TORINO 2	SAMSUNG ELECTRONICS
CHECK	GUO LEI	DEV STEP	MP	MAIN		
APPROVAL	KEVIN LEE	REV	1,1	DMB & KBD & DEBUG & POWER S/W	PART NO.	BA41-00727/8A
MODULE CODE		LAST EDIT		March 28, 2007 3:33:29 PM	PAGE	49 OF 54

SAMSUNG PROPRIETARY
 THIS DOCUMENT CONTAINS CONFIDENTIAL
 PROPRIETARY INFORMATION THAT IS
 SAMSUNG ELECTRONICS CO'S PROPERTY.
 DO NOT DISCLOSE TO OR DUPLICATE FOR OTHERS
 EXCEPT AS AUTHORIZED BY SAMSUNG.

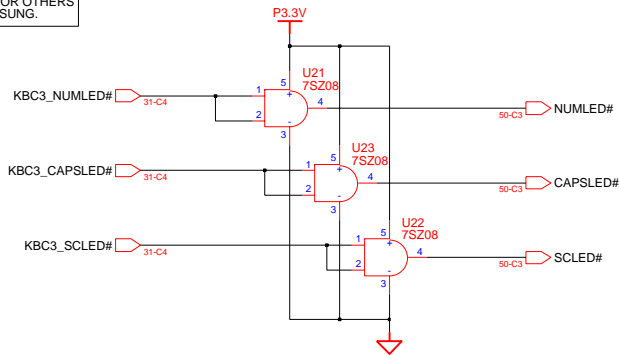

LEDS

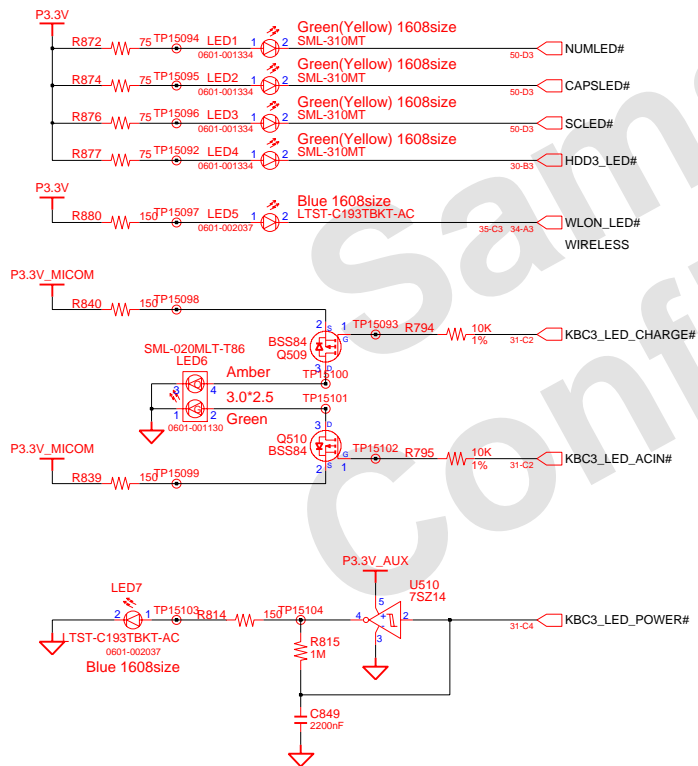

TOUCH PAD

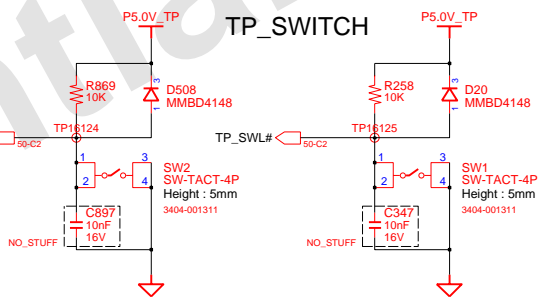
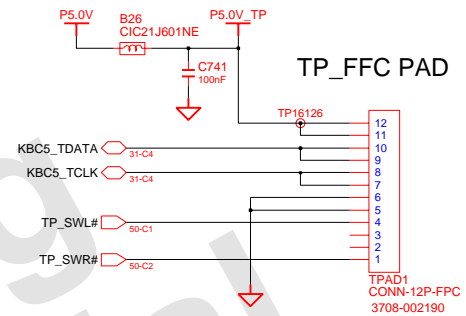

DRAW	ZHOU JUN	DATE	4/10/2007	TITLE	TORINO 2	SAMSUNG ELECTRONICS
CHECK	GUO LEI	DEV. STEP	MP	MAIN	MAIN	
APPROVAL	KEVIN LEE	REV	1,1	TOUCH PAD & LEDS	PART NO.	BA41-00727/8A
MODULE CODE		LAST EDIT			PAGE	50 OF 54
				March 28, 2007 3:33:29 PM		

SAMSUNG PROPRIETARY
 THIS DOCUMENT CONTAINS CONFIDENTIAL
 PROPRIETARY INFORMATION THAT IS
 SAMSUNG ELECTRONICS CO'S PROPERTY.
 DO NOT DISCLOSE TO OR DUPLICATE FOR OTHERS
 EXCEPT AS AUTHORIZED BY SAMSUNG.

DMB-NUT

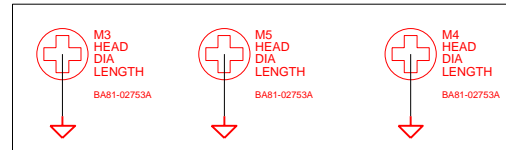

NUT for RHE, Locate on TOP of PCB

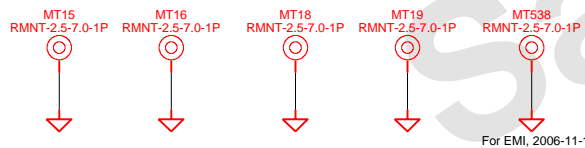
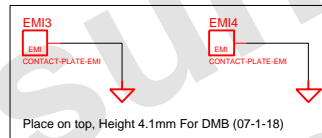
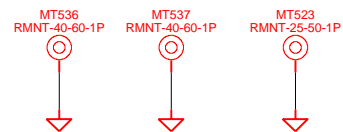
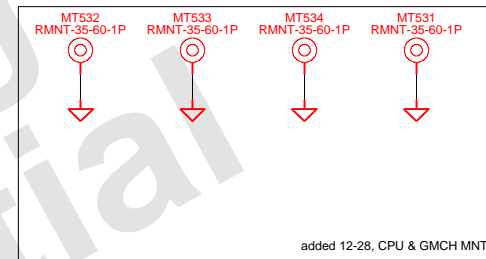
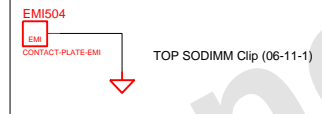
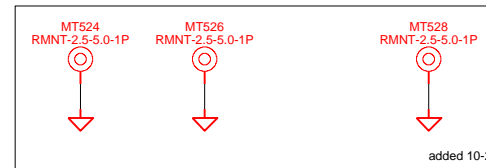
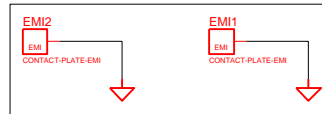
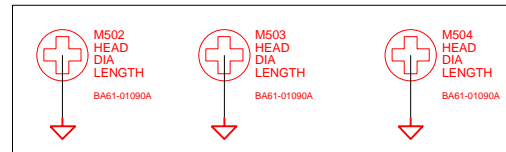

1 - 499 SIDE

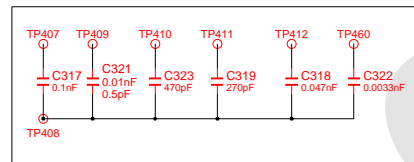

500 - SIDE

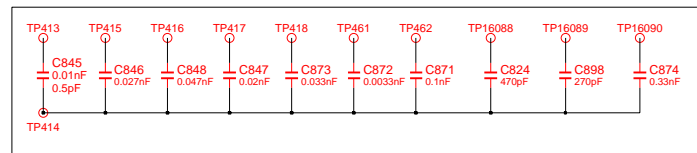

REV1
 1 O
 2 O O3

PCB REVISION CONTROL (ICT)				
NO	CONNECTION	DATE(Y/M/M/DD)	REVISION	STEP
1	N.C.			
2	1-2			
3	2-3			
4	3-1			
5	1-2-3			
6	N.C.			
7	1-2			
8	2-3			
9	3-1			
10	1-2-3			

DRAW	ZHOU JUN	DATE	4/10/2007	TITLE	TORINO 2 MAIN MOUNT HOLE	SAMSUNG ELECTRONICS PART NO. BA41-00727/8A
CHECK	GUO LEI	DEV. STEP	MP			
APPROVAL	KEVIN LEE	REV	1,1			
MODULE CODE		LAST EDIT				
			March 28, 2007 3:33:29 PM	PAGE	51	OF 54

SAMSUNG PROPRIETARY
 THIS DOCUMENT CONTAINS CONFIDENTIAL
 PROPRIETARY INFORMATION THAT IS
 SAMSUNG ELECTRONICS CO'S PROPERTY.
 DO NOT DISCLOSE TO OR DUPLICATE FOR OTHERS
 EXCEPT AS AUTHORIZED BY SAMSUNG.

TORINO2 ON TOP BOARD

T2_SUB

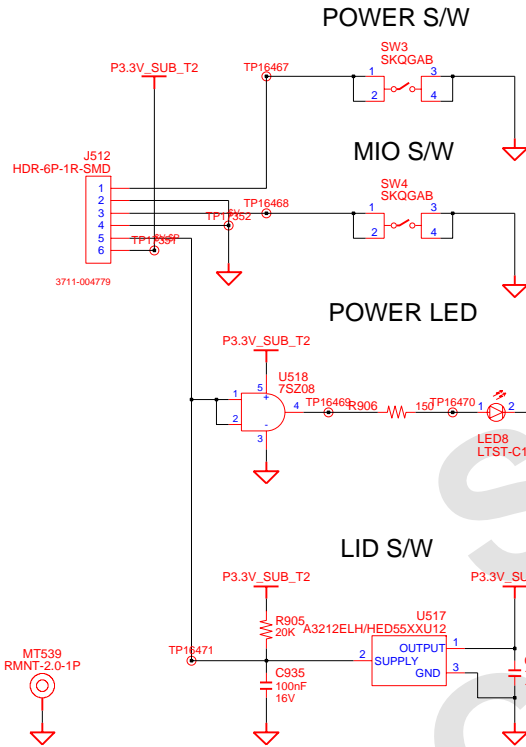

BEIJING ON TOP BOARD

BJ_SUB

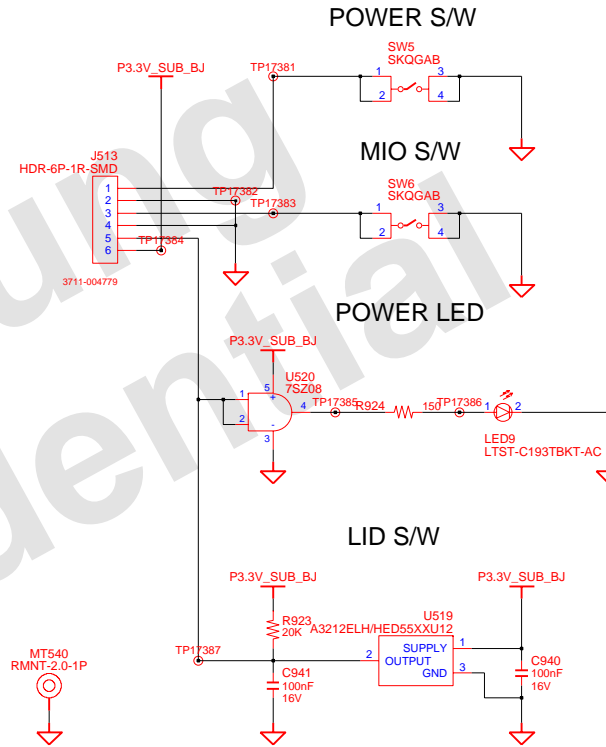

Drill size: 2.2mm
 PAD size: TOP 6.0mm
 Bottom 5.0mm

DRAW	ZHOU JUN	DATE	4/10/2007	TITLE	TORINO 2 MAIN ON TOP BOARD	SAMSUNG ELECTRONICS
CHECK	GUO LEI	DEV. STEP	MP			PART NO. BA41-00727/8A
APPROVAL	KEVIN LEE	REV	1,1			
MODULE CODE		LAST EDIT	March 28, 2007 3:33:29 PM	PAGE	53	OF 54

SAMSUNG PROPRIETARY
 THIS DOCUMENT CONTAINS CONFIDENTIAL
 PROPRIETARY INFORMATION THAT IS
 SAMSUNG ELECTRONICS CO'S PROPERTY.
 DO NOT DISCLOSE TO OR DUPLICATE FOR OTHERS
 EXCEPT AS AUTHORIZED BY SAMSUNG.

REVISION HISTORY

REVISION	DATE	NO.#	CONTENTS
----------	------	------	----------

Samsung
Confidential

NOTES

Note1. Schematic Revision: MP 1 . 0 . 0
 Development Stage
 PCB Version
 Schematic Version

Note2. PCB SEC Code
 Vendor: SGCE P/N: BA41-??????
 Vendor: TPT P/N: BA41-??????

DRAW	ZHOU JUN	DATE	4/10/2007	TITLE	TORINO 2	SAMSUNG ELECTRONICS
CHECK	GUO LEI	DEV STEP	MP	MAIN		
APPROVAL	KEVIN LEE	REV	1,1	REVISION HISTORY		PART NO. BA41-00727/8A
MODULE CODE		LAST EDIT	March 28, 2007 3:33:29 PM	PAGE	54	OF 54