

**SAMSUNG PROPRIETARY**

THIS DOCUMENT CONTAINS CONFIDENTIAL  
 PROPRIETARY INFORMATION THAT IS  
 SAMSUNG ELECTRONICS CO.'S PROPERTY.  
 DO NOT DISCLOSE TO OR DUPLICATE FOR OTHERS  
 EXCEPT AS AUTHORIZED BY SAMSUNG.

# MACAO

CPU : STEALEY (A110)  
 Chip Set : 945GU + ICH7-U  
 Remarks : Ultra Mobile PC  
 WSVGA, HSDPA, DMB

Model Name : MACAO  
 PBA Name : BA41-00743A  
 Dev. Step : SR  
 Revision : 0.1  
 T.R. Date : 2007.03.15

DRAW	CHECK	APPROVAL
W.S. Ko	H.K.Park	J.S. Euh

## Table of Contents

Page.1 ---- Cover  
 Page.2 ---- Operation Block diagram  
 Page.3 ---- Power Sequence  
 Page.4 ---- Clock distribution  
 Page.5 ---- Board Information  
 Page.6 ---- Clock Generator  
 Page.7~9 --- Stealey - CPU  
 Page.10 ---- THERMAL SENSOR & FAN  
 Page.11~14- Little River - GMCH  
 Page.15 ---- SODIMM Connector  
 Page.16~19- ICH7-U  
 Page.20 ---- FWH & 80PORT  
 Page.21 ---- RGB Encoder - sDVO to RGB  
 Page.22 ---- CRT Connector - RGB  
 Page.23 ---- TCon Sub Board Connector  
 Page.24 ---- HDD Connector & I2C to PS2  
 Page.25 ---- DMB & USB Jack  
 Page.26 ---- MICOM  
 Page.27 ---- SD / MMC Memory Card Controller  
 Page.28 ---- WirelessLAN(PCI-E 1x)  
 Page.29 ---- Wibro / HSDPA (USB)  
 Page.30 ---- Wired LAN Connector  
 Page.31 ---- Sub Board Connector & Switches  
 Page.32 ---- Audio Codec(ALC262-GR)  
 Page.33 ---- AMP & Speaker  
 Page.34 ---- Phone Jack & MIC  
 Page.35 ---- Charger & Power Management  
 Page.36 ---- P3.3V\_AUX / P5V\_AUX / P3.3V\_MICOM  
 Page.37 ---- P1.5V / VCCP\_CORE  
 Page.38 ---- DDR2 Power  
 Page.39 ---- CPU VRM  
 Page.40 ---- Switched Powers  
 Page.41 ---- Mount Hole / RHE Pem  
 Page.42~44- Sub Board - LAN (BCM4401)  
 Page.45 ---- SD/MMC Socket & USB Jack (Up)  
 Page.46 ---- Sub Board - Left  
 Page.47 ---- Sub Board - FingerPrint

DRAW	KO, W.S.	DATE	3/15/2007	TITLE	Macao	<b>SAMSUNG</b> ELECTRONICS
CHECK	PARK, H.K.	DEV. STEP	SR	COVER	PART NO.	
APPROVAL	EUH, J.S.	REV	1.0			BA41-00743A
MODULE CODE		LAST EDIT	March 15, 2007 12:01:15 PM	PAGE	1	OF 47

**SAMSUNG PROPRIETARY**  
 THIS DOCUMENT CONTAINS CONFIDENTIAL  
 PROPRIETARY INFORMATION THAT IS  
 SAMSUNG ELECTRONICS CO.'S PROPERTY.  
 DO NOT DISCLOSE TO OR DUPLICATE FOR OTHERS  
 EXCEPT AS AUTHORIZED BY SAMSUNG.

# OPERATION BLOCK DIAGRAM

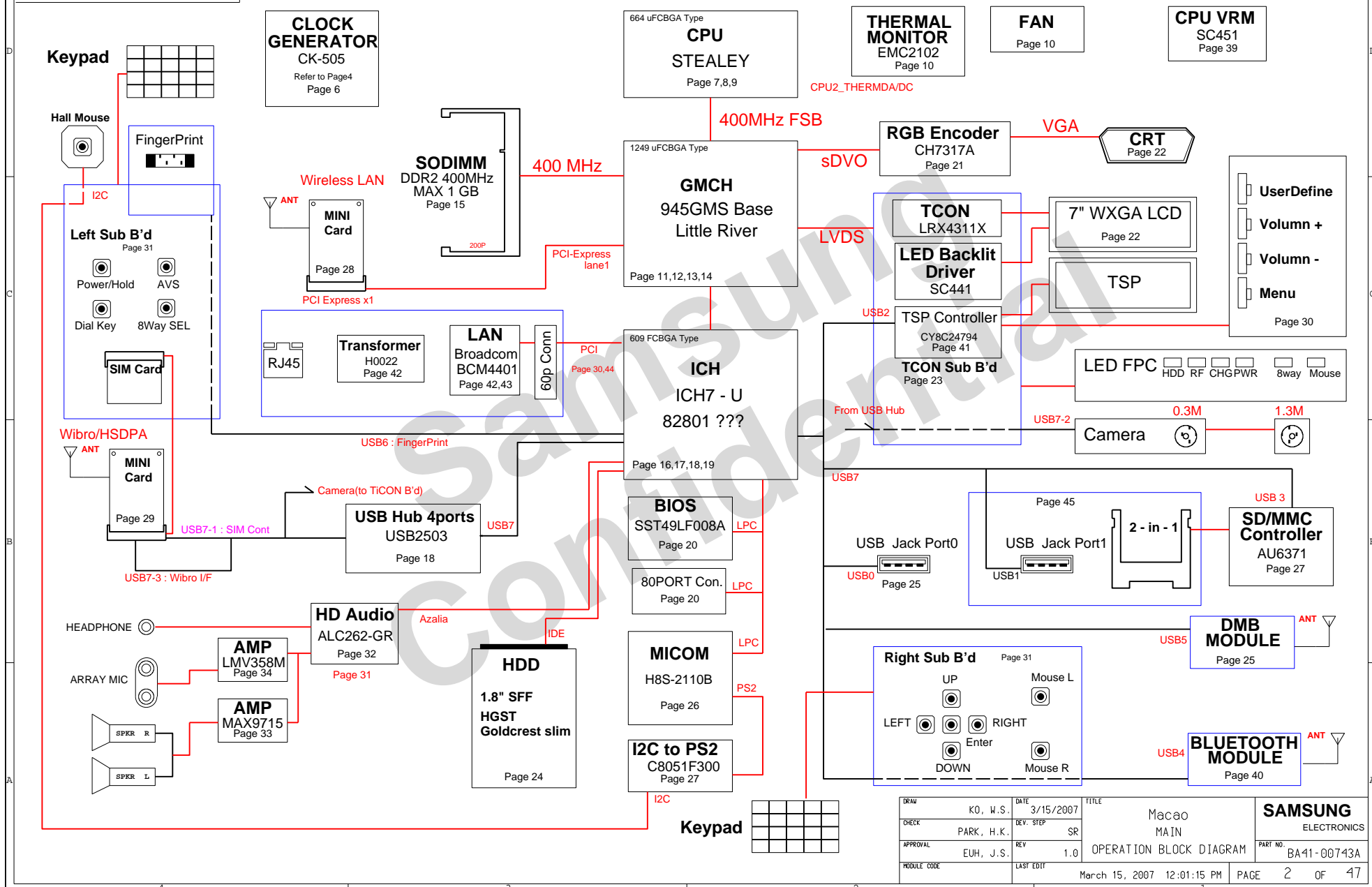

DRAW	KO, W.S.	DATE	3/15/2007	TITLE	Macao	SAMSUNG ELECTRONICS
CHECK	PARK, H.K.	DEV. STEP	SR	MAIN		
APPROVAL	EUH, J.S.	REV	1.0	OPERATION BLOCK DIAGRAM	PART NO.	BA41-00743A
MODULE CODE		LAST EDIT	March 15, 2007 12:01:15 PM	PAGE	2	OF 47

**SAMSUNG PROPRIETARY**

THIS DOCUMENT CONTAINS CONFIDENTIAL PROPRIETARY INFORMATION THAT IS SAMSUNG ELECTRONICS CO.'S PROPERTY. DO NOT DISCLOSE TO OR DUPLICATE FOR OTHERS EXCEPT AS AUTHORIZED BY SAMSUNG.

# Power Sequence Block Diagram

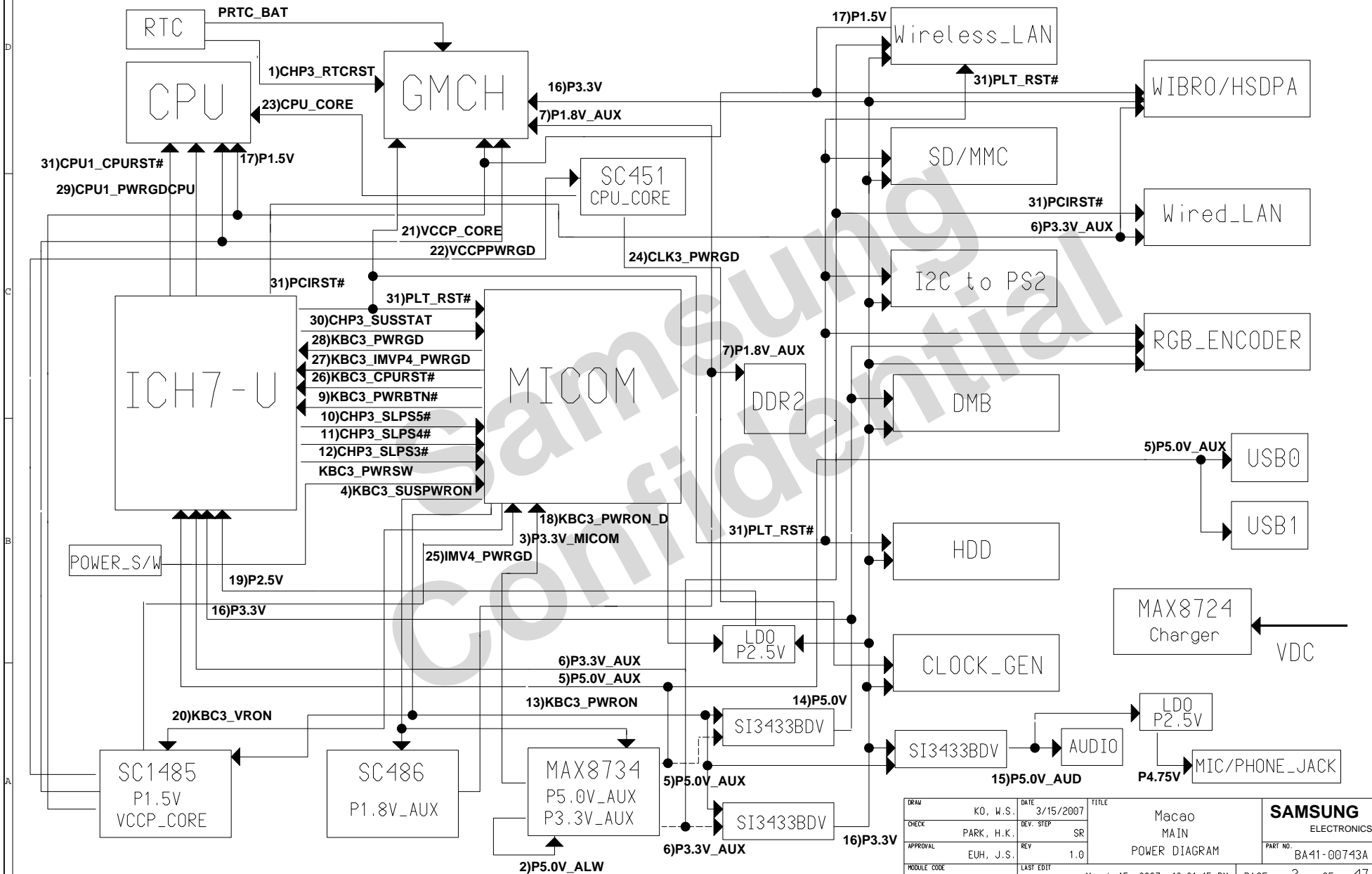

DRAW	KO, W.S.	DATE	3/15/2007	TITLE	Macao	<b>SAMSUNG</b> ELECTRONICS
CHECK	PARK, H.K.	DEV. STEP	SR	MAIN	PART NO.	
APPROVAL	EUH, J.S.	REV	1.0	POWER DIAGRAM	BA41-00743A	
MODULE CODE		LAST EDIT	March 15, 2007 12:01:15 PM	PAGE	3 OF 47	

**SAMSUNG PROPRIETARY**

THIS DOCUMENT CONTAINS CONFIDENTIAL PROPRIETARY INFORMATION THAT IS SAMSUNG ELECTRONICS CO.'S PROPERTY. DO NOT DISCLOSE TO OR DUPLICATE FOR OTHERS EXCEPT AS AUTHORIZED BY SAMSUNG.

# CLOCK DISTRIBUTION

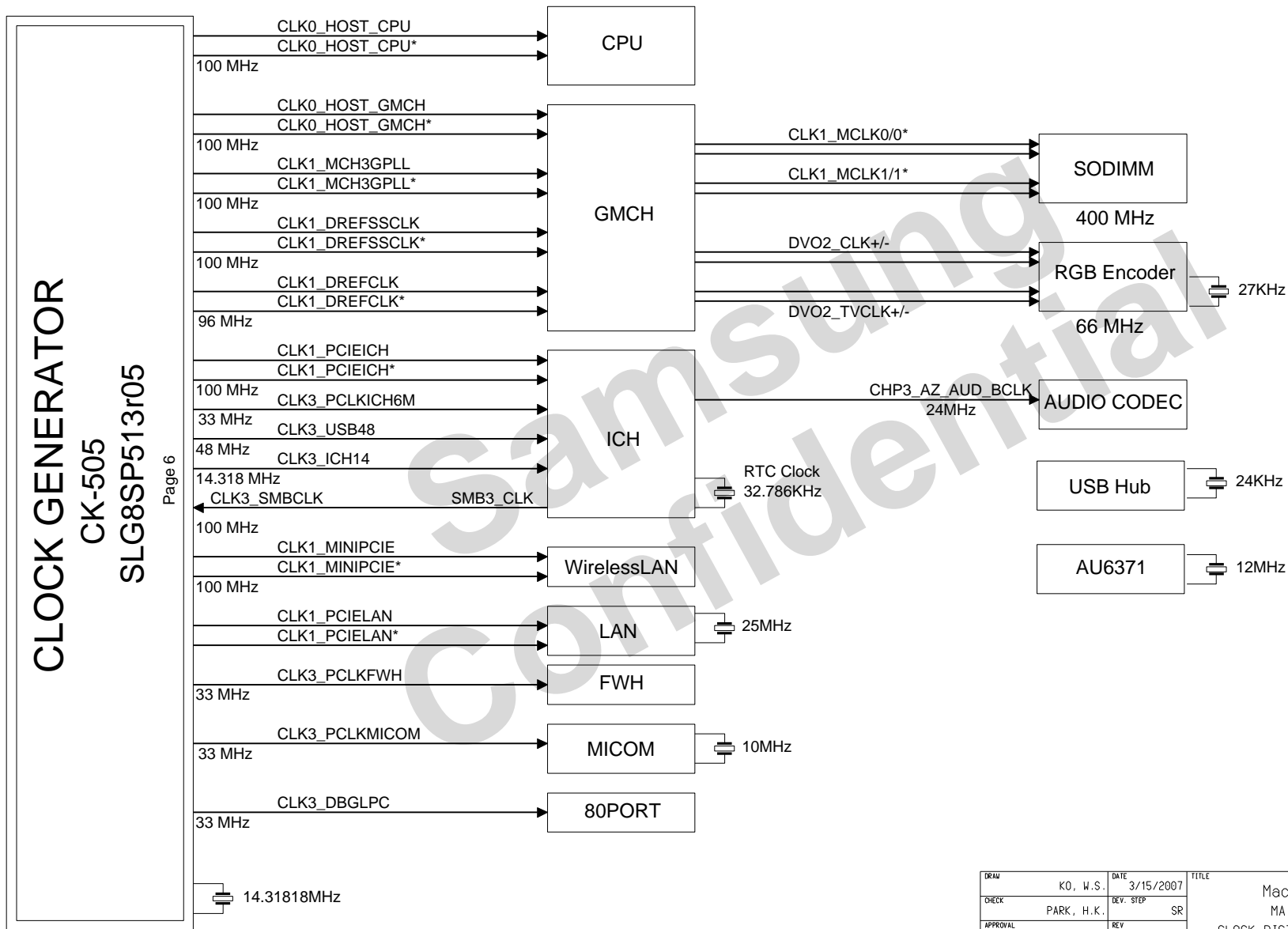

**CLOCK GENERATOR**  
**CK-505**  
**SLG8SP513r05**

Page 6

DRAW	KO, W.S.	DATE	3/15/2007	TITLE	Macao	SAMSUNG ELECTRONICS
CHECK	PARK, H.K.	DEV. STEP	SR	MAIN		
APPROVAL	EUH, J.S.	REV	1.0	CLOCK DISTRIBUTION	PART NO.	BA41-00743A
MODULE CODE		LAST EDIT	March 15, 2007 12:01:15 PM	PAGE	4	OF 47

**SAMSUNG PROPRIETARY**

THIS DOCUMENT CONTAINS CONFIDENTIAL PROPRIETARY INFORMATION THAT IS SAMSUNG ELECTRONICS CO.'S PROPERTY. DO NOT DISCLOSE TO OR DUPLICATE FOR OTHERS EXCEPT AS AUTHORIZED BY SAMSUNG.

# BOARD INFORMATION

## SCHEMATIC ANNOTATIONS AND BOARD INFORMATION

### PCI Devices

Devices	IDSEL#	REQ/GNT#	Interrupts
Wired LAN	AD21	3	G
USB Hub to PCI LPC Bridge/IDE/AC97/SMBUS	AD29(internal) AD30(internal) AD31(internal)	Programable	

### I<sup>2</sup>C / SMB Address

Devices	Address	Hex	Bus
<b>ICH6M</b>	<b>Master</b>	-	<b>SMBUS Master</b>
CK-510M (Clock Generator)	1101 001x	D2h	Clock, Unused Clock Output Disable
SODIMMO	1010 000X	A0h	
USB Hub	1010 000X	A0h	
<b>MICOM</b>	<b>Master</b>		
BATTERY	0001 011h	16h	
THERMAL MORNORIT	x111 1010	7Ah	
HALL MOUSE	x001 1100	1Ch	

### USB PORT Assign

Port0	Right USB JACK
Port1	Left USB JACK
Port2	Touch Sensor Panel
Port3	SD/MMC Controller
Port4	Bluetooth
Port5	DMB
Port6	FingerPrint
Port7	USB Hub - 1. USIM Controller 2. Camera 3. Wibro / HSDPA

### System Power States

Power Rail	Devices (Page Number)
<b>P5V</b>	FAN(10) 80PORT(20) MICOM(25) DMB(25) RGB_ENCODER(21) AUDIO AMP(32)
<b>P3.3V</b>	CLOCK(6) Thermal sensor(10) SODIMM(15) ICH7(17) 80PORT(20) HDD(24)WIBRO/HSDPA(29)SD/MMC(27) MICOM(26) DMB(25) I2CtoPS2(24)GMCH(11)Wireless_LAN(28)
<b>P1.5V</b>	CPU(7) GMCH(11) ICH7(16) WIBRO/HSDPA(29)SC1485(37)
<b>P2.5V</b>	GMCH(11)ICH7(16)RGB_ENCODER(21)
<b>P5V_AUX</b>	ICH7(16) USB0(25)USB1(45)MAX8734(36)
<b>P3.3V_AUX</b>	ICH7(16)Wired_LAN(30) WIBRO/HSDPA(29)MAX8734(36)
<b>P1.8V_AUX</b>	GMCH(11) SODIMM(15) SC486(35)
<b>VCCP_CORE</b>	CPU(7) GMCH(11) ICH7(16) SC1485(37)
<b>VCC_CORE</b>	CPU(7)SC451(39)

### Voltage Rails

Power Rail	Descriptions
<b>PRTC_BAT VDC</b>	3.3V (can drop to 2.0V min. in G3 state) supply for the RTC well. Primary DC system power supply (6 to 19V)
<b>P5V_AUX</b> <b>P3.3V_AUX</b> <b>P1.8V_AUX</b>	5.0V power rail (off in S4-S5) 3.3V power rail (off in S4-S5) GMCH/DDR II Power Source(off in S4-S5)
<b>P5V</b> <b>P3.3V</b> <b>P1.5V</b> <b>P2.5V</b>	5.0V switched power rail (off in S3-S5) 3.3V switched power rail (off in S3-S5) 1.5V switched power rail (off in S3-S5) 2.5V LDO power rail (off in S3-S5)
<b>VCCP_CORE</b> <b>CPU_CORE</b>	1.05V power rail, GMCH core, CPU/GMCH FSB Termination. Core voltage for Stealey CPU (0.74~1.30V)
<b>P3.3V_MICOM</b> <b>P1.5V_DMI</b>	3.3V always on power rail for MICOM 1.5V (Direct Media Interface Compensation)
<b>LCD_VDD3V</b> <b>VCC_CRT</b>	3.3V (LCD) 5V (CRT)
<b>P4.75_AUD</b> <b>P5.0V_AMP</b>	4.75V (ALC262) 5V (Audio AMP)

### CPU Core Voltage Table

VID5	VID4	VID3	VID2	VID1	VID0	Voltage	VID5	VID4	VID3	VID2	VID1	VID0	Voltage
0	0	0	0	0	0	1.708 V	1	0	0	0	0	0	1.196 V
0	0	0	0	0	1	1.692 V	1	0	0	0	0	1	1.180 V
0	0	0	0	1	0	1.676 V	1	0	0	0	1	0	1.164 V
0	0	0	0	1	1	1.660 V	1	0	0	0	1	1	1.148 V
0	0	0	1	0	0	1.644 V	1	0	0	1	0	0	1.132 V
0	0	0	1	0	1	1.628 V	1	0	0	0	1	1	1.116 V
0	0	0	1	1	0	1.612 V	1	0	0	1	1	0	1.100 V
0	0	0	1	1	1	1.596 V	1	0	0	1	1	1	1.084 V
0	0	1	0	0	0	1.580 V	1	0	1	0	0	0	1.068 V
0	0	1	0	0	1	1.564 V	1	0	1	0	0	1	1.052 V
0	0	1	0	1	0	1.548 V	1	0	1	0	1	0	1.036 V
0	0	1	0	1	1	1.532 V	1	0	1	0	1	1	1.020 V
0	0	1	1	0	0	1.516 V	1	0	1	1	0	0	1.004 V
0	0	1	1	0	1	1.500 V	1	0	1	1	1	0	0.988 V
0	0	1	1	1	0	1.484 V	1	0	1	1	1	0	0.972 V
0	0	1	1	1	1	1.468 V	1	0	1	1	1	1	0.956 V
0	1	0	0	0	0	1.452 V	1	1	0	0	0	0	0.940 V
0	1	0	0	0	1	1.436 V	1	1	0	0	0	1	0.924 V
0	1	0	0	1	0	1.420 V	1	1	0	0	1	0	0.908 V
0	1	0	0	1	1	1.404 V	1	1	0	0	1	1	0.892 V
0	1	0	1	0	0	1.388 V	1	1	0	1	0	0	0.876 V
0	1	0	1	0	1	1.372 V	1	1	0	1	0	1	0.860 V
0	1	0	1	1	0	1.356 V	1	1	0	1	1	0	0.844 V
0	1	0	1	1	1	1.340 V	1	1	0	1	1	1	0.828 V
0	1	1	0	0	0	1.324 V	1	1	1	0	0	0	0.812 V
0	1	1	0	0	1	1.308 V	1	1	1	0	0	1	0.796 V
0	1	1	0	1	0	1.292 V	1	1	1	0	1	0	0.780 V
0	1	1	0	1	1	1.276 V	1	1	1	0	1	1	0.764 V
0	1	1	1	0	0	1.260 V	1	1	1	1	0	0	0.748 V
0	1	1	1	0	1	1.244 V	1	1	1	1	0	1	0.732 V
0	1	1	1	1	0	1.228 V	1	1	1	1	1	0	0.716 V
0	1	1	1	1	1	1.212 V	1	1	1	1	1	1	0.700 V

DOTHAN-ULV Base Stealey  
HIGH FREQUENCY MODE

DOTHAN-ULV Base Stealey  
LOW FREQUENCY MODE

DOTHAN-ULV Base Stealey  
DEEPER SLEEP MODE  
Refer to page??

DRAW	KO, W.S.	DATE	3/15/2007	TITLE	Macao	<b>SAMSUNG</b> ELECTRONICS
CHECK	PARK, H.K.	DEV. STEP	SR		MAIN	
APPROVAL	EUH, J.S.	REV	1.0		BOARD INFORMATION	PART NO. BA41-00743A
MODULE CODE		LAST EDIT	March 15, 2007 12:01:15 PM	PAGE	5	OF 47

**SAMSUNG PROPRIETARY**

THIS DOCUMENT CONTAINS CONFIDENTIAL PROPRIETARY INFORMATION THAT IS SAMSUNG ELECTRONICS CO.'S PROPERTY. DO NOT DISCLOSE TO OR DUPLICATE FOR OTHERS EXCEPT AS AUTHORIZED BY SAMSUNG.

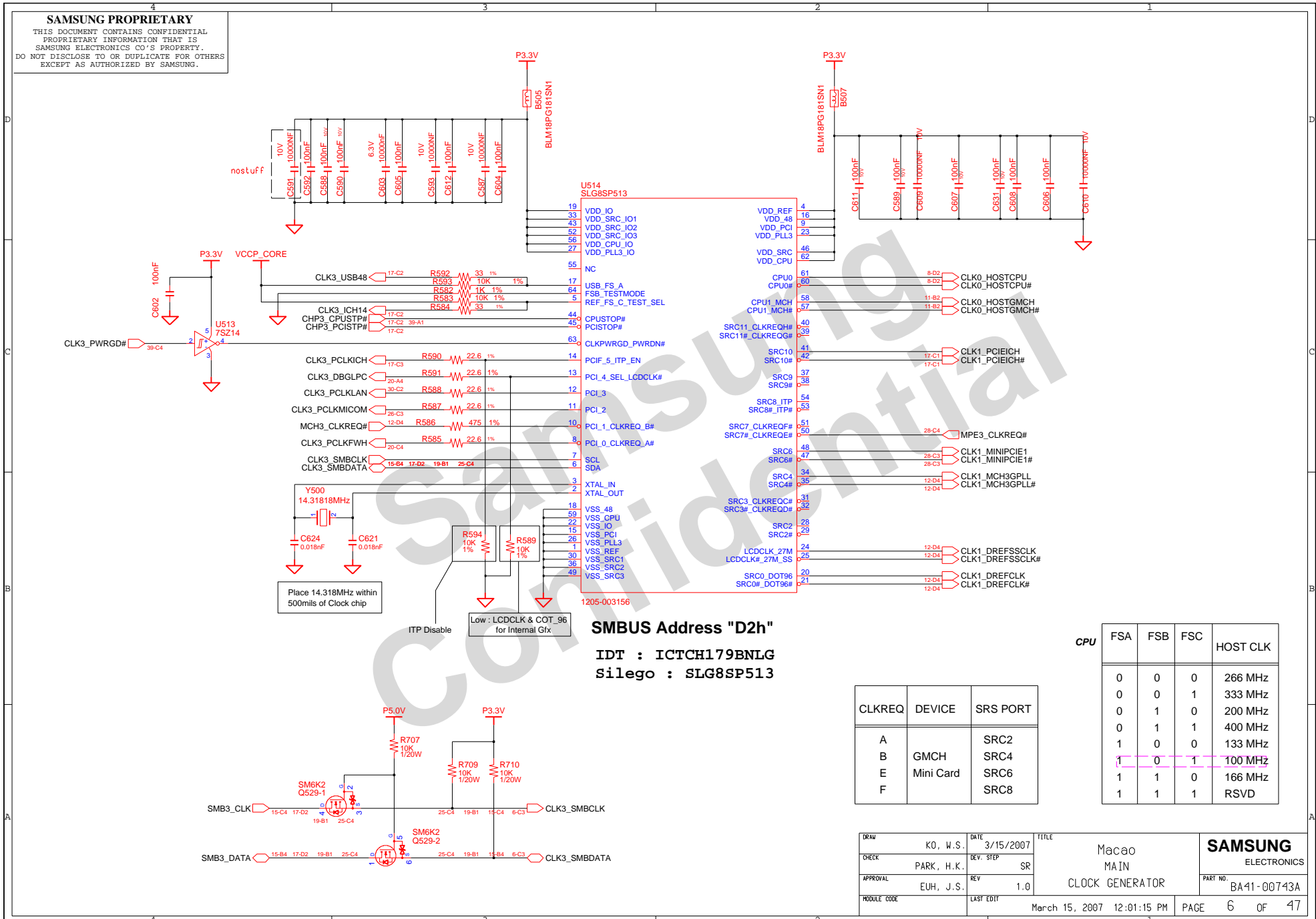

Place 14.318MHz within 500mils of Clock chip

ITP Disable

Low : LCDCLK & COT\_96 for Internal Gix

**SMBUS Address "D2h"**

IDT : ICTCH179BNLG

Silego : SLG8SP513

CLKREQ	DEVICE	SRS PORT
A	GMCH	SRC2
B	Mini Card	SRC4
E		SRC6
F		SRC8

CPU	FSA	FSB	FSC	HOST CLK
	0	0	0	266 MHz
	0	0	1	333 MHz
	0	1	0	200 MHz
	0	1	1	400 MHz
	1	0	0	133 MHz
	1	0	1	100 MHz
	1	1	0	166 MHz
	1	1	1	RSVD

DRAW	KO, W.S.	DATE	3/15/2007	TITLE	Macao MAIN	<b>SAMSUNG</b> ELECTRONICS
CHECK	PARK, H.K.	DEV. STEP	SR	CLOCK GENERATOR	PART NO.	
APPROVAL	EUH, J.S.	REV	1.0		BA41-00743A	
MODULE CODE		LAST EDIT	March 15, 2007 12:01:15 PM	PAGE	6	OF 47

**SAMSUNG PROPRIETARY**

THIS DOCUMENT CONTAINS CONFIDENTIAL PROPRIETARY INFORMATION THAT IS SAMSUNG ELECTRONICS CO.'S PROPERTY. DO NOT DISCLOSE TO OR DUPLICATE FOR OTHERS EXCEPT AS AUTHORIZED BY SAMSUNG.

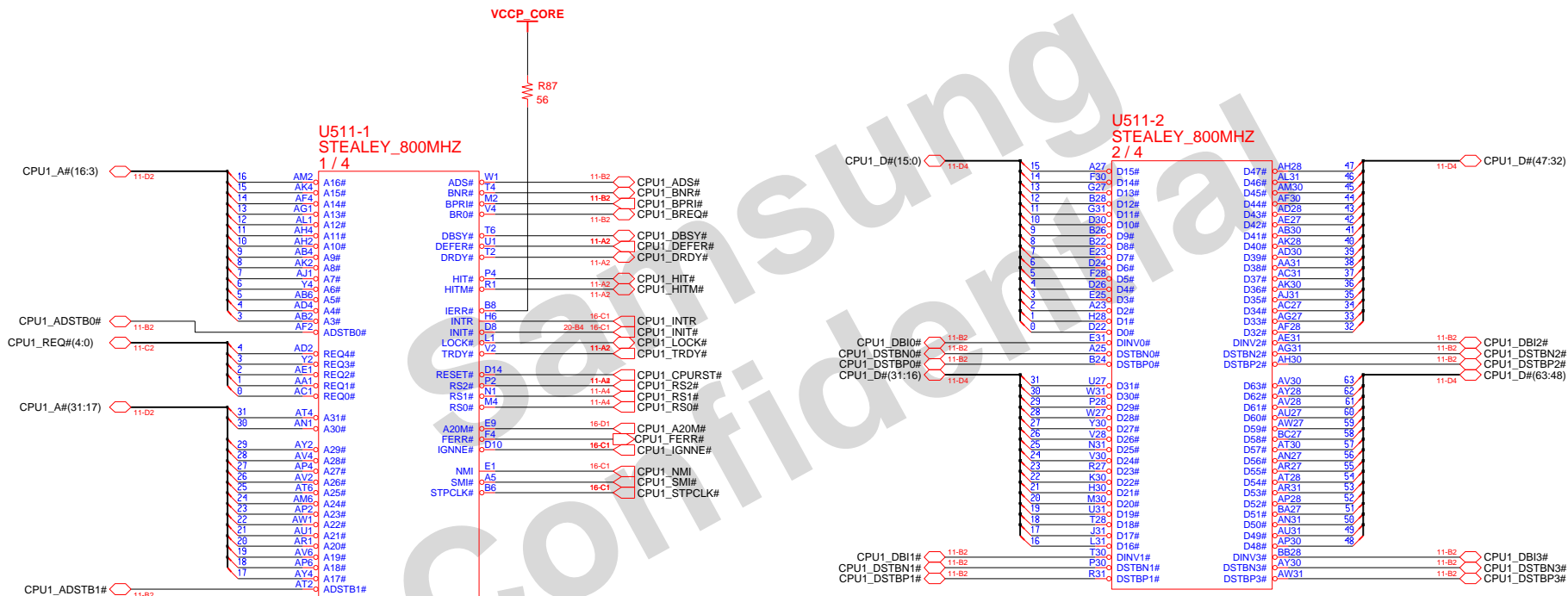

DRAW	KO, W.S.	DATE	3/15/2007	TITLE	Macao	SAMSUNG ELECTRONICS
CHECK	PARK, H.K.	DEV. STEP	SR	MAIN		
APPROVAL	EUH, J.S.	REV	1.0	STEALEY CPU( 1/3)	PART NO.	BA41-00743A
MODULE CODE		LAST EDIT	March 15, 2007 12:01:15 PM	PAGE	7	OF 47

**SAMSUNG PROPRIETARY**

THIS DOCUMENT CONTAINS CONFIDENTIAL PROPRIETARY INFORMATION THAT IS SAMSUNG ELECTRONICS CO.'S PROPERTY. DO NOT DISCLOSE TO OR DUPLICATE FOR OTHERS EXCEPT AS AUTHORIZED BY SAMSUNG.

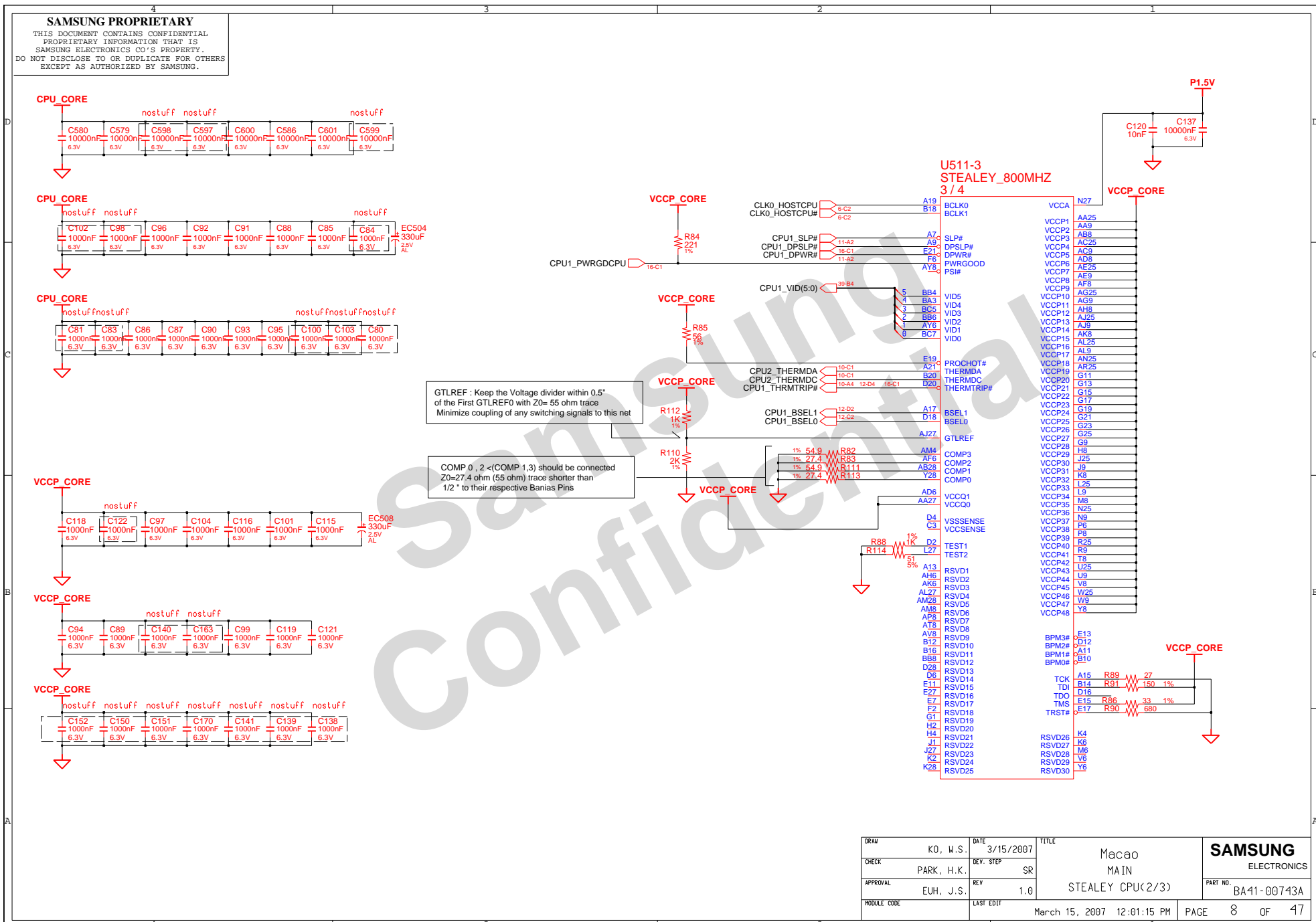

DRAW	KO, W.S.	DATE	3/15/2007	TITLE	Macao	SAMSUNG ELECTRONICS
CHECK	PARK, H.K.	DEV. STEP	SR	MAIN		
APPROVAL	EUH, J.S.	REV	1.0	STEALEY CPU(2/3)	PART NO.	BA41-00743A
MODULE CODE		LAST EDIT	March 15, 2007 12:01:15 PM	PAGE	8	OF 47



**SAMSUNG PROPRIETARY**

THIS DOCUMENT CONTAINS CONFIDENTIAL PROPRIETARY INFORMATION THAT IS SAMSUNG ELECTRONICS CO.'S PROPERTY. DO NOT DISCLOSE TO OR DUPLICATE FOR OTHERS EXCEPT AS AUTHORIZED BY SAMSUNG.

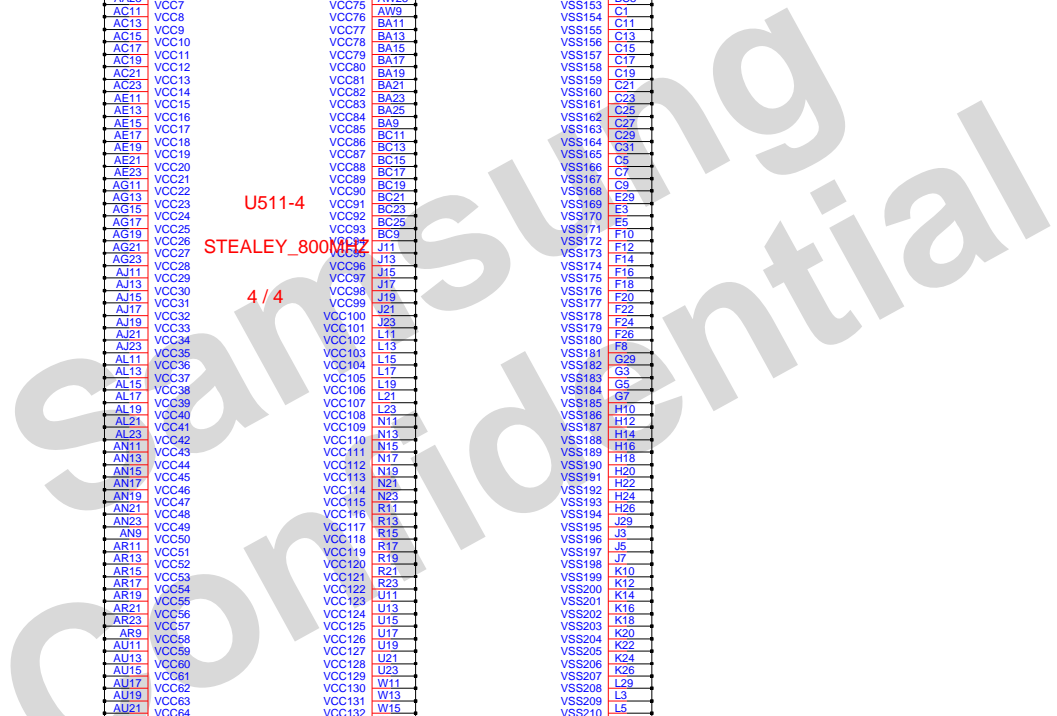

DRAW	KO, W.S.	DATE	3/15/2007	TITLE	Macao	SAMSUNG ELECTRONICS
CHECK	PARK, H.K.	DEV. STEP	SR	MAIN	PART NO.	
APPROVAL	EUH, J.S.	REV	1.0	STEALEY CPU( 3/3)	BA41-00743A	
MODULE CODE		LAST EDIT	March 15, 2007 12:01:15 PM	PAGE	9 OF 47	

**SAMSUNG PROPRIETARY**

THIS DOCUMENT CONTAINS CONFIDENTIAL PROPRIETARY INFORMATION THAT IS SAMSUNG ELECTRONICS CO.'S PROPERTY. DO NOT DISCLOSE TO OR DUPLICATE FOR OTHERS EXCEPT AS AUTHORIZED BY SAMSUNG.

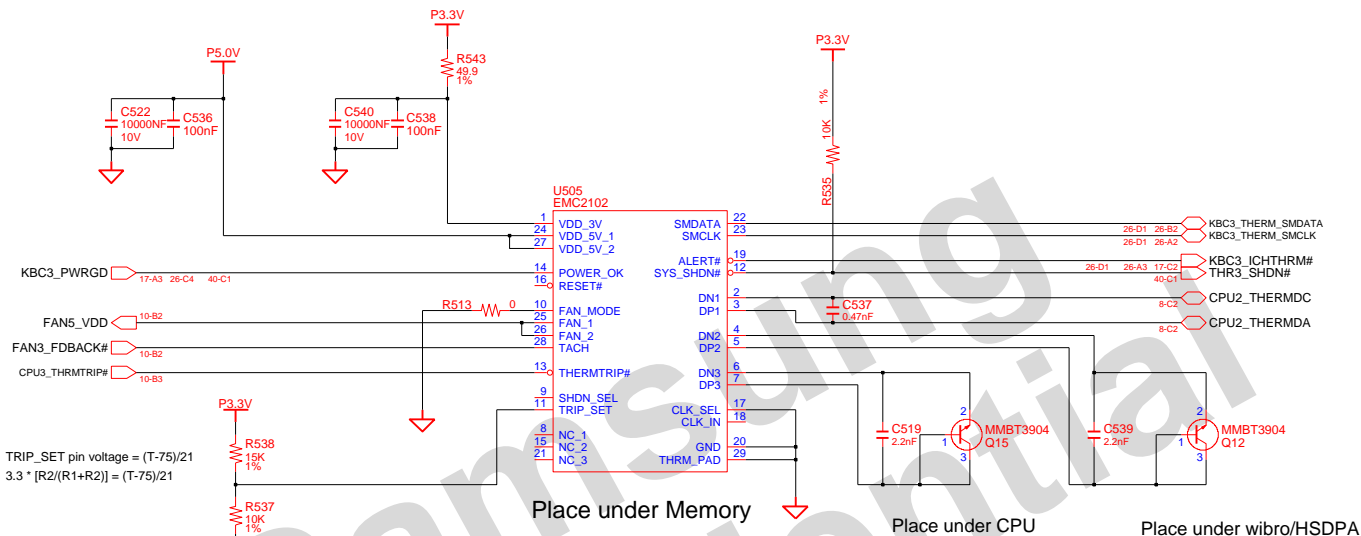

TRIP\_SET pin voltage =  $(T-75)/21$   
 $3.3 * [R2/(R1+R2)] = (T-75)/21$

Place under Memory

Place under CPU

Place under wibro/HSDPA

**CPU Thermal Sensor**  
 SMBUS Addr"7Ah"(x111 1010)

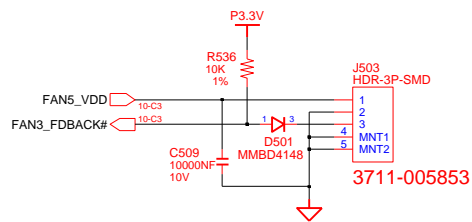
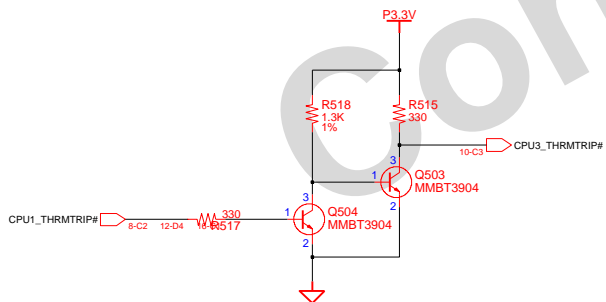

DRAW	KO, W.S.	DATE	3/15/2007	TITLE	Macao	<b>SAMSUNG</b> ELECTRONICS
CHECK	PARK, H.K.	DEV. STEP	SR	MAIN		
APPROVAL	EUH, J.S.	REV	1.0	Thermal, FAN, Shutdown		PART NO. BA41-00743A
MODULE CODE		LAST EDIT	March 15, 2007 12:01:15 PM	PAGE	10	OF 47

**SAMSUNG PROPRIETARY**

THIS DOCUMENT CONTAINS CONFIDENTIAL PROPRIETARY INFORMATION THAT IS SAMSUNG ELECTRONICS CO.'S PROPERTY. DO NOT DISCLOSE TO OR DUPLICATE FOR OTHERS EXCEPT AS AUTHORIZED BY SAMSUNG.

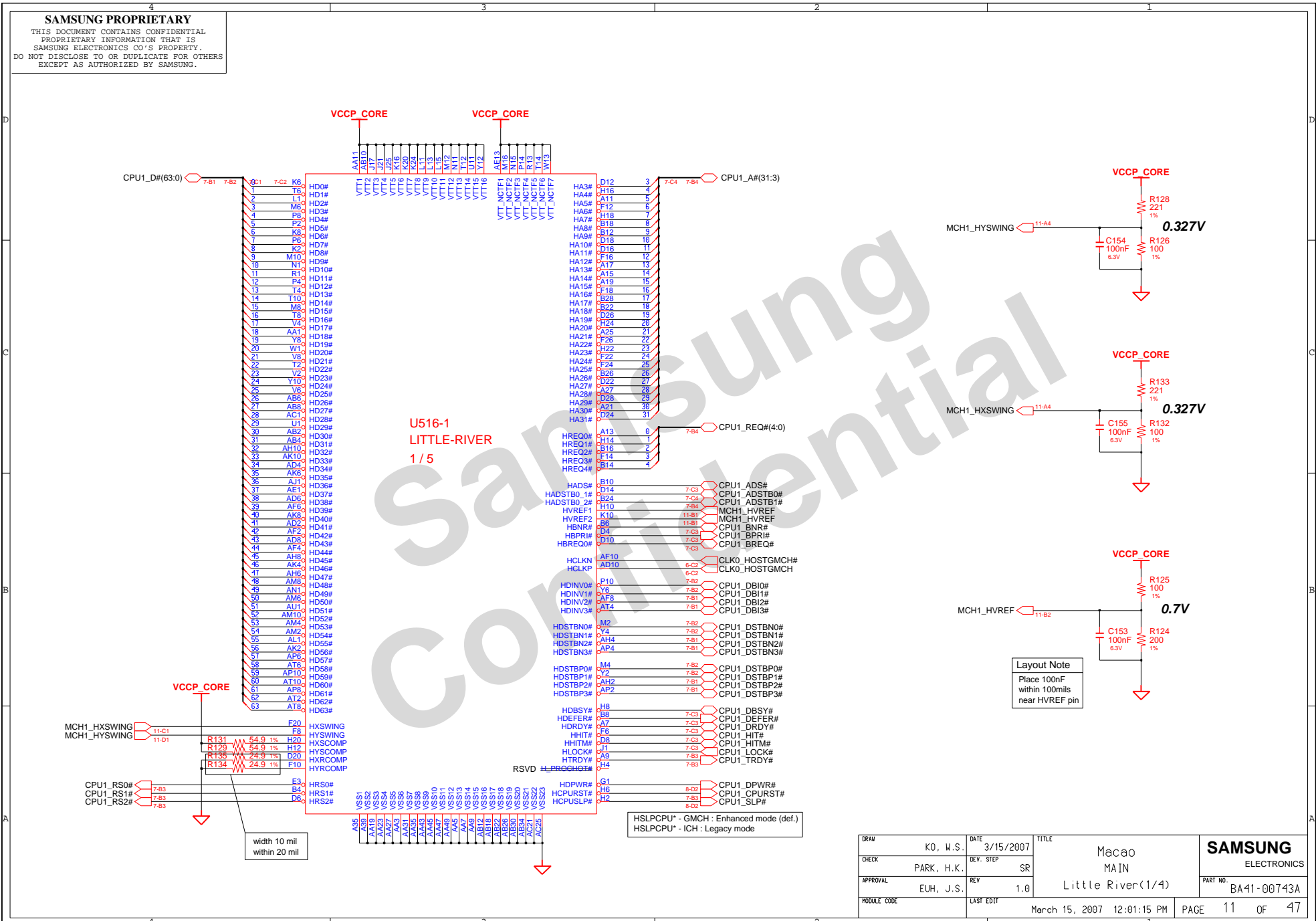

**Layout Note**  
Place 100nF within 100mils near HVREF pin

DRAW	K0, W.S.	DATE	3/15/2007	TITLE	Macao	<b>SAMSUNG</b> ELECTRONICS
CHECK	PARK, H.K.	DEV. STEP	SR	MAIN		
APPROVAL	EUH, J.S.	REV	1.0	Little River(1/4)		PART NO. BA41-00743A
MODULE CODE		LAST EDIT	March 15, 2007 12:01:15 PM	PAGE	11	OF 47

**SAMSUNG PROPRIETARY**

THIS DOCUMENT CONTAINS CONFIDENTIAL PROPRIETARY INFORMATION THAT IS SAMSUNG ELECTRONICS CO.'S PROPERTY. DO NOT DISCLOSE TO OR DUPLICATE FOR OTHERS EXCEPT AS AUTHORIZED BY SAMSUNG.

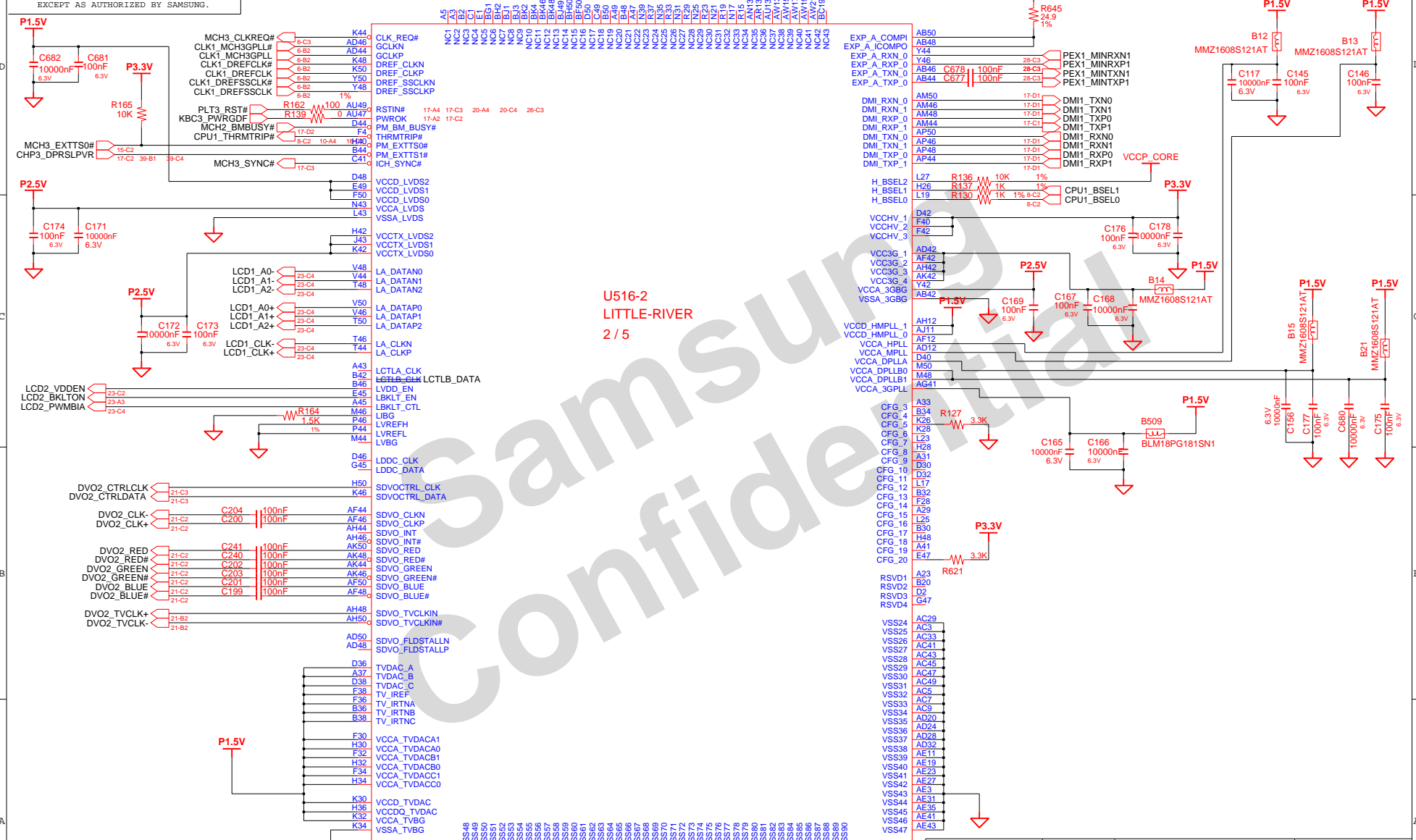

U516-2  
LITTLE-RIVER  
2 / 5

DRAW	KO, W.S.	DATE	3/15/2007	TITLE	Macao	<b>SAMSUNG</b> ELECTRONICS
CHECK	PARK, H.K.	DEV. STEP	SR		MAIN	
APPROVAL	EUH, J.S.	REV	1.0		Little River(2/4)	PART NO. BA41-00743A
MODULE CODE		LAST EDIT			March 15, 2007 12:01:15 PM	PAGE 12 OF 47

**SAMSUNG PROPRIETARY**

THIS DOCUMENT CONTAINS CONFIDENTIAL PROPRIETARY INFORMATION THAT IS SAMSUNG ELECTRONICS CO.'S PROPERTY. DO NOT DISCLOSE TO OR DUPLICATE FOR OTHERS EXCEPT AS AUTHORIZED BY SAMSUNG.

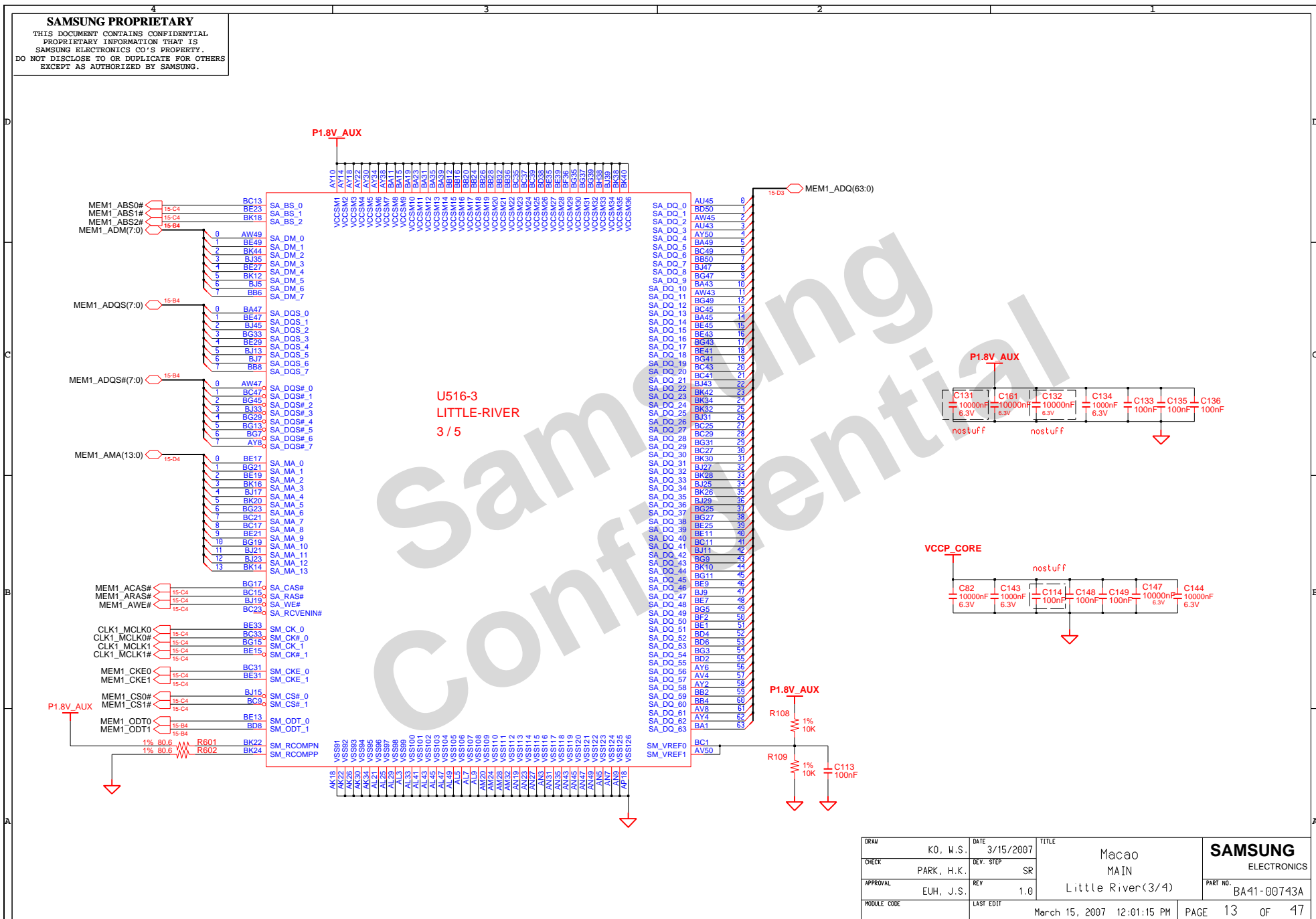

DRAW	KO, W.S.	DATE	3/15/2007	TITLE	Macao	<b>SAMSUNG</b> ELECTRONICS
CHECK	PARK, H.K.	DEV. STEP	SR	MAIN		
APPROVAL	EUH, J.S.	REV	1.0	Little River(3/4)		PART NO.
MODULE CODE		LAST EDIT	March 15, 2007 12:01:15 PM	PAGE	13	OF 47

**SAMSUNG PROPRIETARY**

THIS DOCUMENT CONTAINS CONFIDENTIAL PROPRIETARY INFORMATION THAT IS SAMSUNG ELECTRONICS CO.'S PROPERTY. DO NOT DISCLOSE TO OR DUPLICATE FOR OTHERS EXCEPT AS AUTHORIZED BY SAMSUNG.

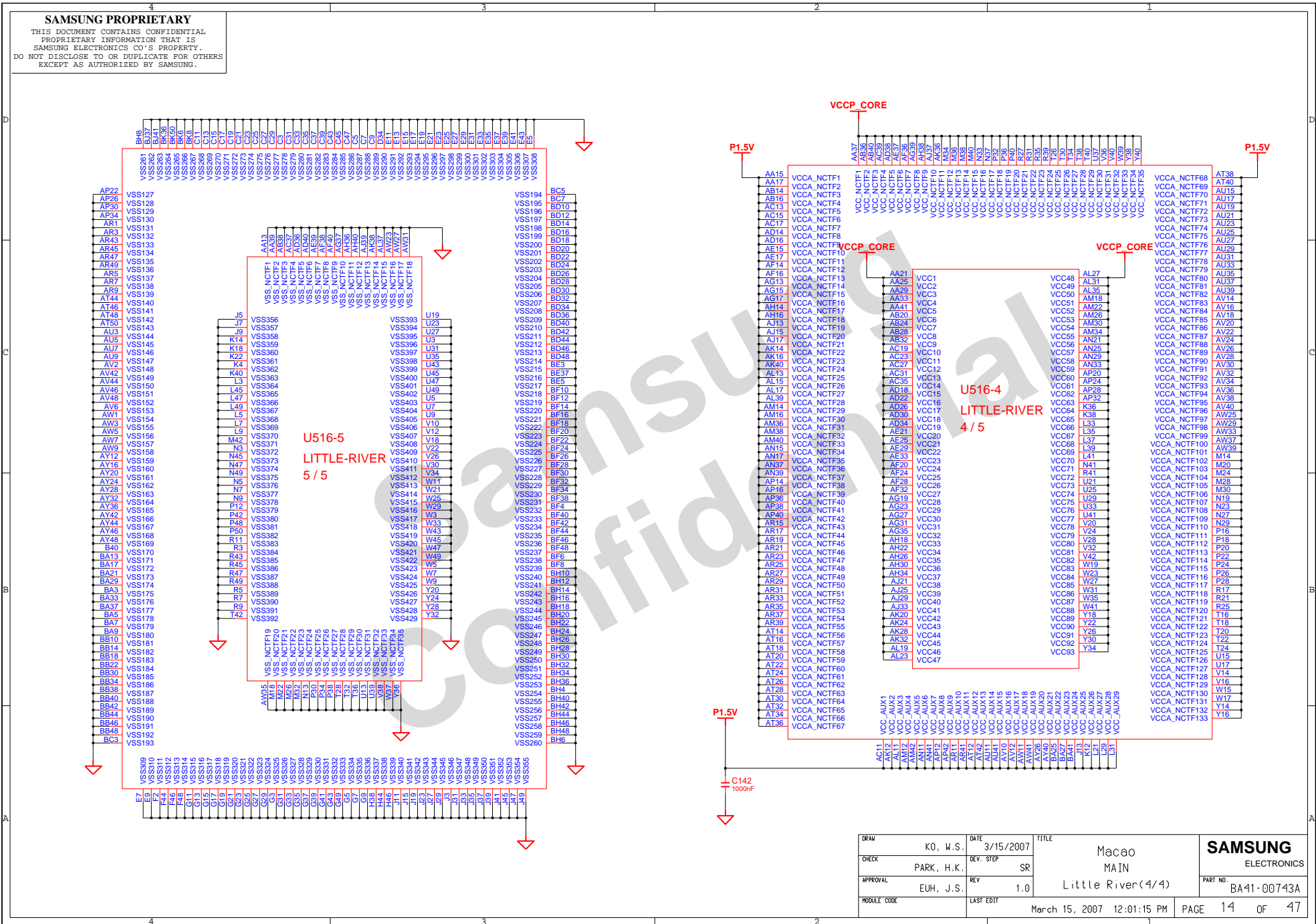

U516-5  
LITTLE-RIVER  
5 / 5

U516-4  
LITTLE-RIVER  
4 / 5

DRAW	KO, W.S.	DATE	3/15/2007	TITLE	Macao	<b>SAMSUNG</b> ELECTRONICS
CHECK	PARK, H.K.	DEV. STEP	SR		MAIN	
APPROVAL	EUH, J.S.	REV	1.0		Little River(4/4)	PART NO. BA41-00743A
MODULE CODE		LAST EDIT		March 15, 2007 12:01:15 PM	PAGE	14 OF 47

**SAMSUNG PROPRIETARY**

THIS DOCUMENT CONTAINS CONFIDENTIAL  
 PROPRIETARY INFORMATION THAT IS  
 SAMSUNG ELECTRONICS CO.'S PROPERTY.  
 DO NOT DISCLOSE TO OR DUPLICATE FOR OTHERS  
 EXCEPT AS AUTHORIZED BY SAMSUNG.

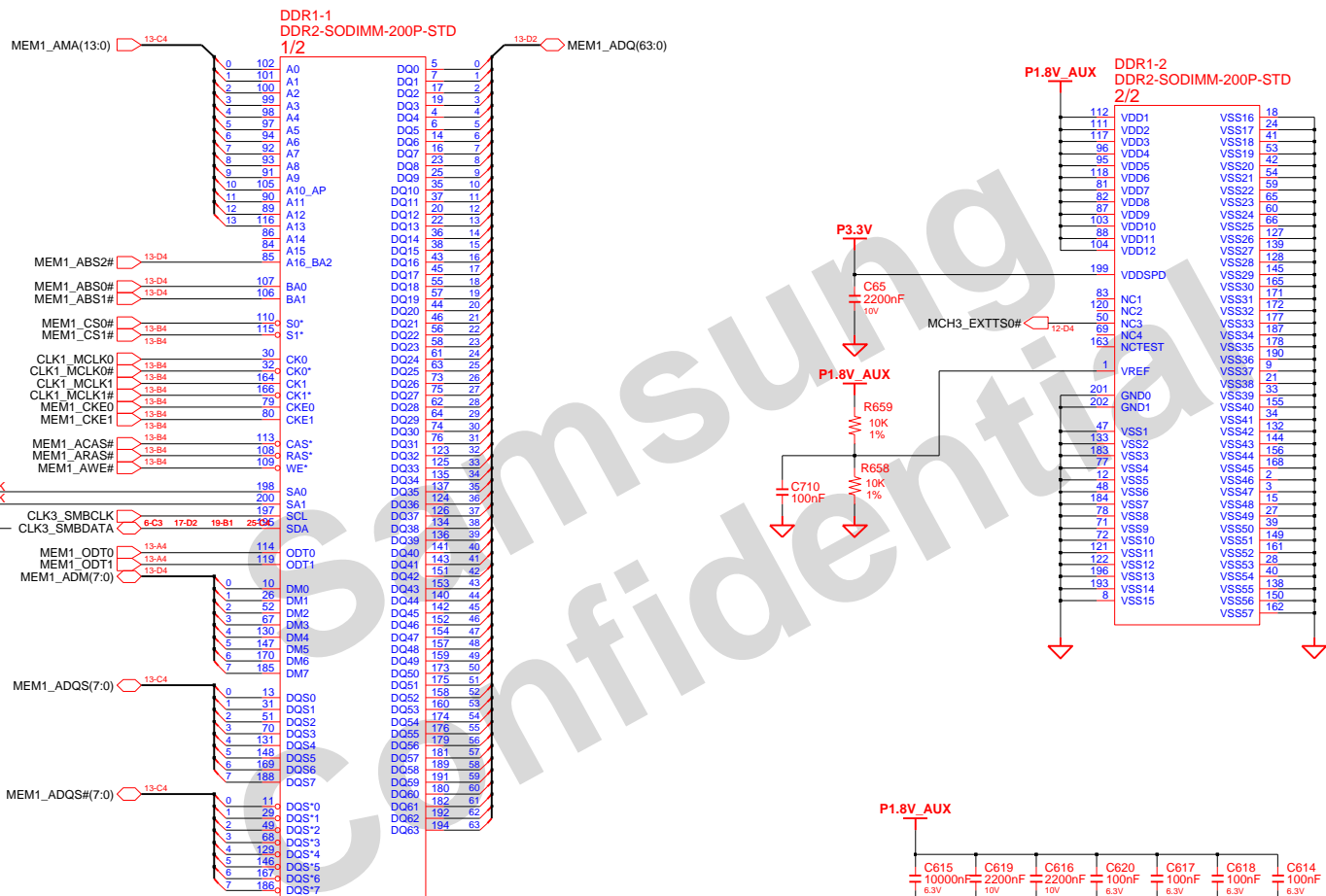

3709-001375

DRAW	KO, W.S.	DATE	3/15/2007	TITLE	Macao	SAMSUNG ELECTRONICS
CHECK	PARK, H.K.	DEV. STEP	SR		MAIN	
APPROVAL	EUH, J.S.	REV	1.0		DDR2 Memory	PART NO. BA41-00743A
MODULE CODE		LAST EDIT	March 15, 2007 12:01:15 PM	PAGE	15	OF 47



**SAMSUNG PROPRIETARY**

THIS DOCUMENT CONTAINS CONFIDENTIAL PROPRIETARY INFORMATION THAT IS SAMSUNG ELECTRONICS CO.'S PROPERTY. DO NOT DISCLOSE TO OR DUPLICATE FOR OTHERS EXCEPT AS AUTHORIZED BY SAMSUNG.

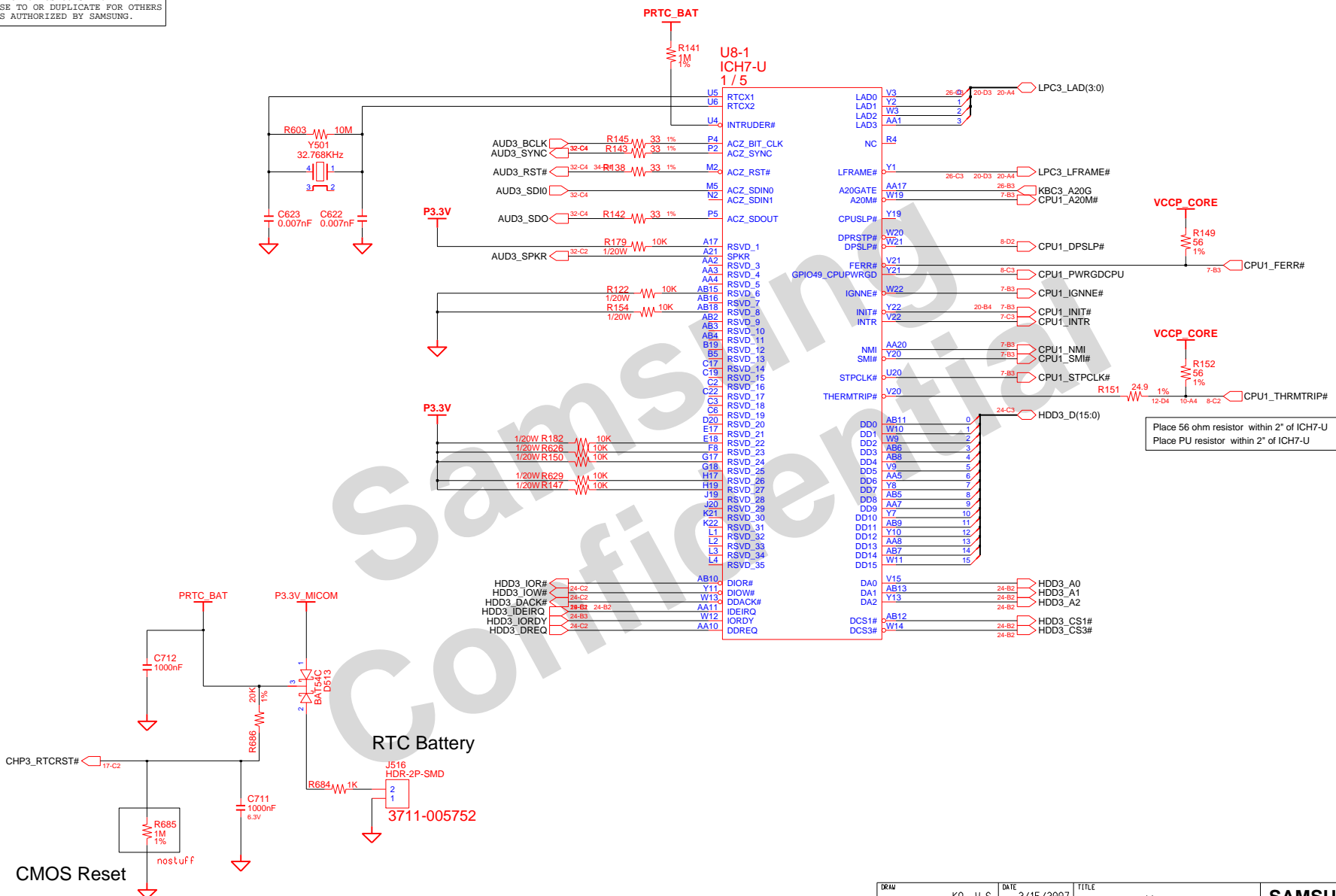

Place 56 ohm resistor within 2" of ICH7-U  
Place PU resistor within 2" of ICH7-U

DRAW	KO, W.S.	DATE	3/15/2007	TITLE	Macao	SAMSUNG ELECTRONICS
CHECK	PARK, H.K.	DEV. STEP	SR	MAIN		
APPROVAL	EUH, J.S.	REV	1.0	ICH7-U(1/4)		PART NO. BA41-00743A
MODULE CODE		LAST EDIT	March 15, 2007 12:01:15 PM	PAGE	16	OF 47



**SAMSUNG PROPRIETARY**

THIS DOCUMENT CONTAINS CONFIDENTIAL PROPRIETARY INFORMATION THAT IS SAMSUNG ELECTRONICS CO.'S PROPERTY. DO NOT DISCLOSE TO OR DUPLICATE FOR OTHERS EXCEPT AS AUTHORIZED BY SAMSUNG.

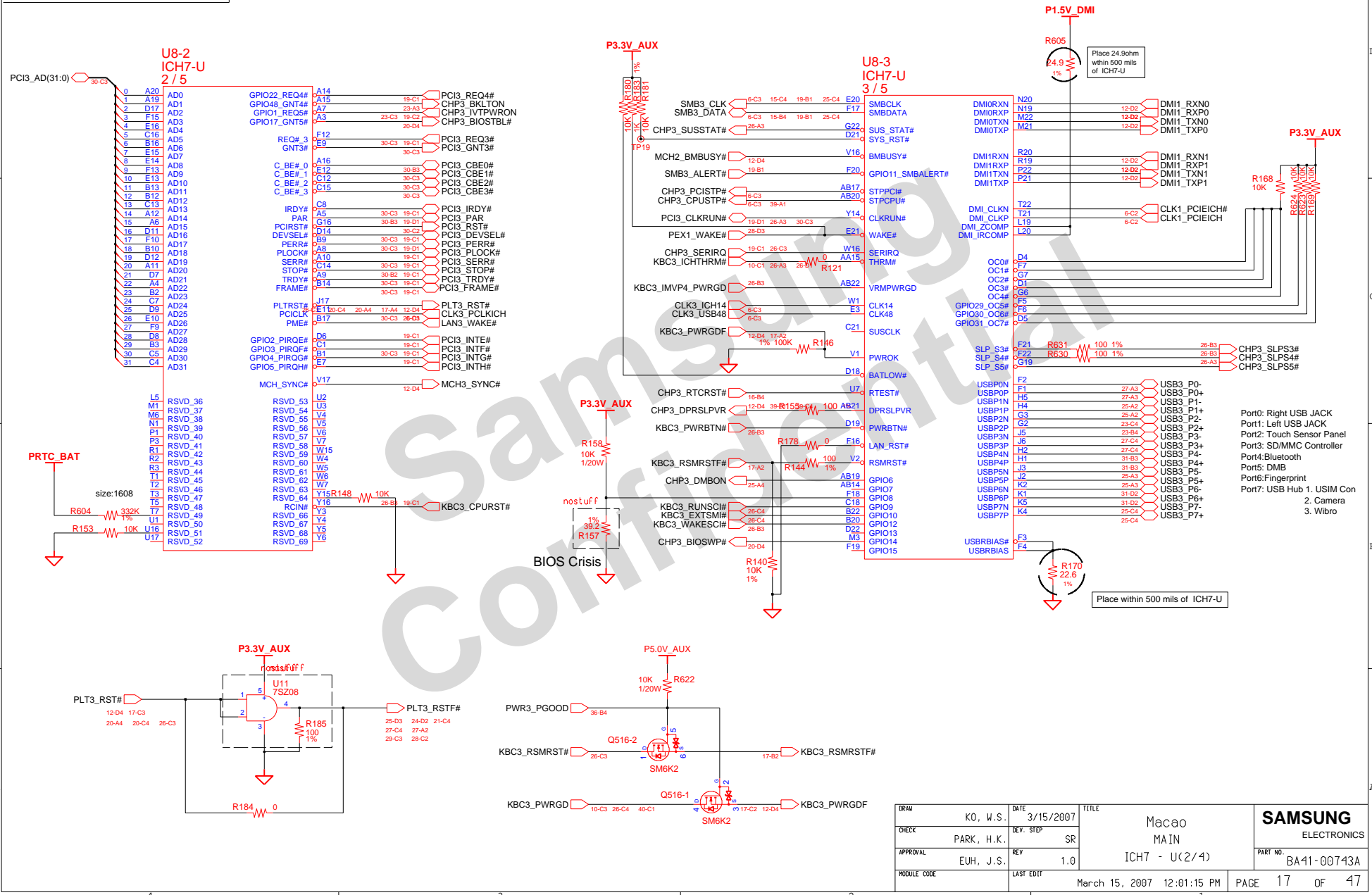

**SAMSUNG PROPRIETARY**

THIS DOCUMENT CONTAINS CONFIDENTIAL  
 PROPRIETARY INFORMATION THAT IS  
 SAMSUNG ELECTRONICS CO.'S PROPERTY.  
 DO NOT DISCLOSE TO OR DUPLICATE FOR OTHERS  
 EXCEPT AS AUTHORIZED BY SAMSUNG.

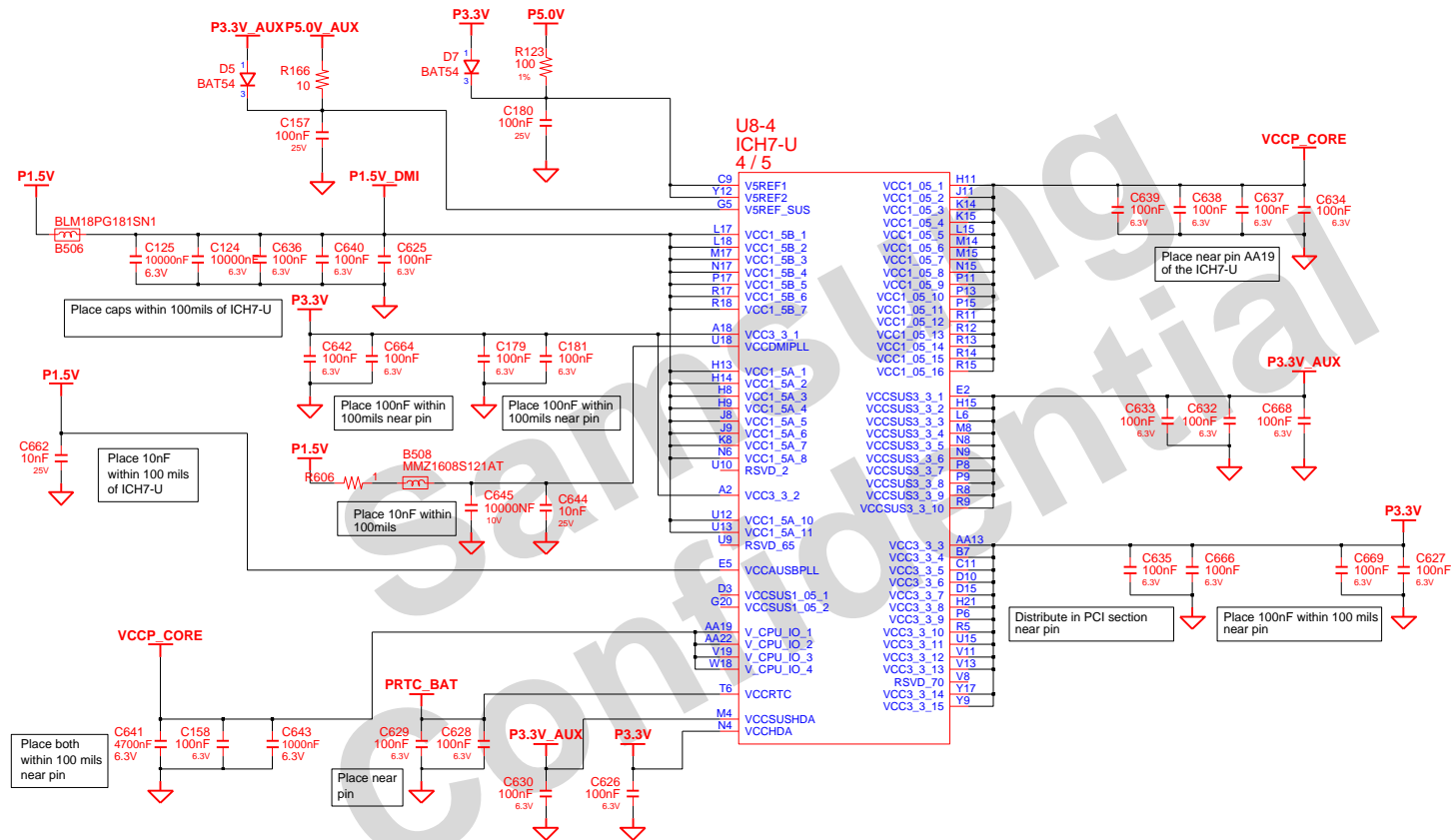

DRAW	KO, W.S.	DATE	3/15/2007	TITLE	Macao	SAMSUNG ELECTRONICS
CHECK	PARK, H.K.	DEV. STEP	SR		MAIN	
APPROVAL	EUH, J.S.	REV	1.0		ICH7 - U(3/4)	PART NO. BA41-00743A
MODULE CODE		LAST EDIT	March 15, 2007 12:01:15 PM	PAGE	18	OF 47

**SAMSUNG PROPRIETARY**

THIS DOCUMENT CONTAINS CONFIDENTIAL  
 PROPRIETARY INFORMATION THAT IS  
 SAMSUNG ELECTRONICS CO.'S PROPERTY.  
 DO NOT DISCLOSE TO OR DUPLICATE FOR OTHERS  
 EXCEPT AS AUTHORIZED BY SAMSUNG.

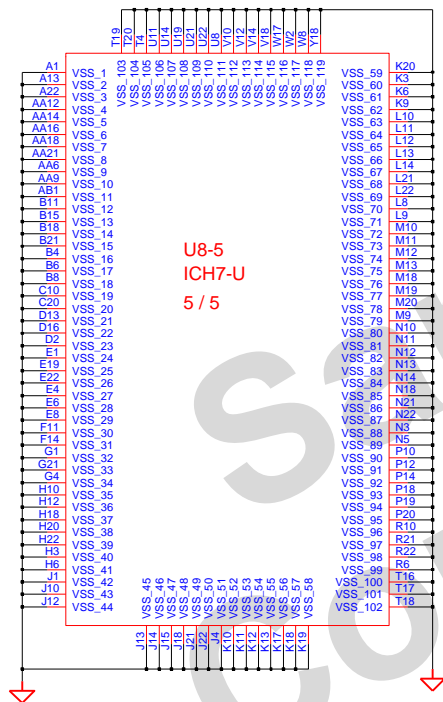

U8-5  
 ICH7-U  
 5/5

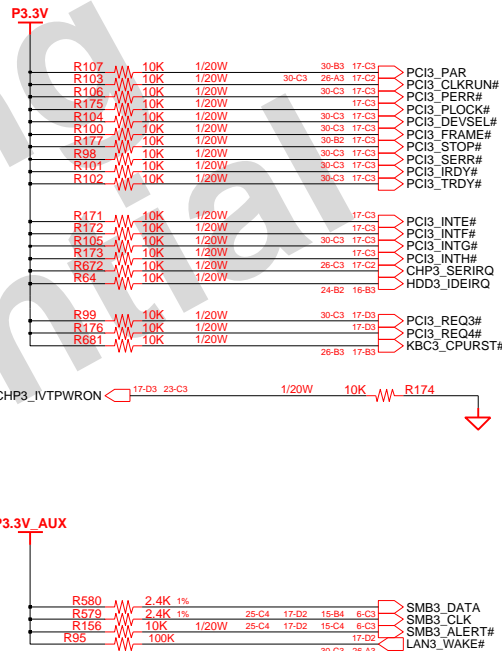

DRAW	KO, W.S.	DATE	3/15/2007	TITLE	Macao	<b>SAMSUNG</b> ELECTRONICS
CHECK	PARK, H.K.	DEV. STEP	SR	MAIN	BA41-00743A	
APPROVAL	EUH, J.S.	REV	1.0	ICH7 - U(4/4)	PART NO.	BA41-00743A
MODULE CODE		LAST EDIT	March 15, 2007 12:01:15 PM	PAGE	19	OF 47

**SAMSUNG PROPRIETARY**

THIS DOCUMENT CONTAINS CONFIDENTIAL PROPRIETARY INFORMATION THAT IS SAMSUNG ELECTRONICS CO.'S PROPERTY. DO NOT DISCLOSE TO OR DUPLICATE FOR OTHERS EXCEPT AS AUTHORIZED BY SAMSUNG.

VENDOR: SST, ATMEL

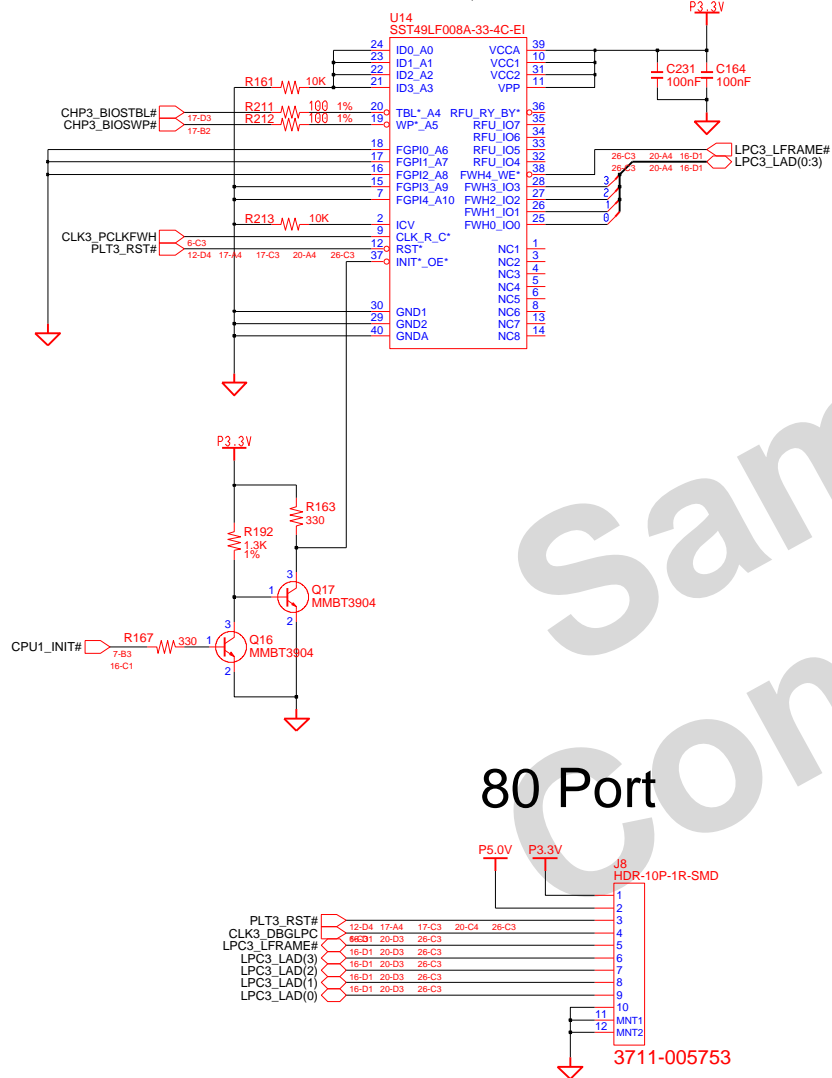

- 02 VERIFY REAL MODE
- 03 DISABLE NMI
- 04 GET CPU TYPE
- 06 INIT. SYSTEM H/W
- 08 INIT. CHIPSET REG.
- 09 SET IN POST FLAG
- 0A INIT CPU.REG
- 0B CPU CACHE ON
- 0C INIT.CACHE TO POST
- 0E INIT. I/O VALUE
- 0F ENABLE THE L-BUS IDE
- 10 INIT. POWER MANAGER
- 11 LOAD ALTERNATE REG.
- 13 PCI BUS MASTER RESET WITH INITIAL POST VALUE
- 14 INIT. KEYBOARD CONTROLLER
- 16 CHECK CHECKSUM
- 18 8254 TIMER INIT.
- 1A 8237 DMA CONTROLLER INIT.
- 1C RESET INTERRUPT CONTROLLER
- 20 TEST DRAM REFRESH
- 22 TEST 8742 KEYBOARD CONTROLLER
- 24 SET ES SEGMENT REG. TO 4GB
- 26 ENABLE A20
- 28 AUTO SIZING DRAM
- 32 COMPUTE THE CPU SPEED
- 34 TESET CMOS RAM
- 38 SHADOW SYSTEM BIOS ROM
- 3A AUTO SIZING CACHE
- 3C CONFIGURE ADVANCED CHIPSET REG.
- 3D LOAD ALTER REG. WITH CMOS VALUE
- 42 INIT. INTERRUPT VECTOR
- 44 INIT. BIOS INTERRUPT
- 46 CHECK ROM COPYRIGHT NOTICE
- 47 INIT. I20 SUPPORT IF INSTALLED
- 48 CHECK VIDEO CONFIGURE AGAINST CMOS
- 49 INIT. PCI BUS AND DEVICE
- 4A INIT. ALL VIDEO BIOS ROM
- 4C SHADOW VIDEO BIOS ROM
- 50 DISPLAY CPU TYPE AND SPEED
- 52 TEST KEYBOARD
- 54 SET KEYCLICK IF ENABLED
- 56 ENABLE KEYBOARD
- 58 TEST FOR UNEXPECTED INTERRUPTS
- 5A DISPLAY " PRESS ..... SETUP"
- 5C TEST RAM BETWEEN 512K AND 640K
- 60 TEST EXTENDED MEMORY
- 62 TEST EXTENDED MEMORY ADDRESS LINE
- 64 JUMP TO USER PATCH 1

- 66 CONFIGURE ADVANCE CACHE REG.
- 6A DISPLAY EXTERNAL CACHE SIZE
- 6C DISPLAY SHADOW MESSAGE
- 6E DISPLAY NON-DISPOSABLE SEGMENT
- 70 DISPLAY ERROR MESSAGE
- 72 CHECK FOR CONFIGURATION ERROR
- 74 TEST REAL-TIME CLOCK
- 76 CHECK FOR KEYBOARD ERROR
- 7C SETUP HARDWARE INTERRUPT VECTOR
- 7E TEST COPROCESSER IF PRESENT
- 80 DISABLE ON-BOARD I/O PORT
- 82 DETECT AND INSTALL EXT.RS232C
- 84 DETECT AND INSTALL EXT.PARALLEL
- 86 RE-INIT. ON-BOARD I/O PORT
- 88 INIT. BIOS DATA ROM
- 8A INIT.EXTENDED BIOS DATA AREA
- 8C INIT. FDD CONTROLLER
- 9A SHADOW OPTION ROMS
- 9C SETUP POWER MANAGEMENT
- 9E ENABLE H/W INTERRUPT
- A0 SET TIME OF DAY
- A4 INIT. TYPOMATIC RATE
- A8 ERASE F2 PROMPT
- AA SCAN FOR F2 KEY STROKE
- AC ENTER SETUP
- AE CLEAR IN POST FLAG
- B0 CHECK FOR ERRORS
- B2 POST DONE-PREPARE TO BOOT O/S
- B4 ONE BEEP
- B6 CHECK PASSWORD (OPTION)
- B7 ACPI INIT
- BA DMI INIT
- BE CLEAR SCREEN
- C0 TRY BOOT WITH INT19
- D0 INTERRUPT HANDLER ERROR
- D2 UNKNOWN INTERRUPT ERROR
- D4 PENDING INTERRUPT ERROR
- D6 SHUTDOWN 5
- D8 SHUTDOWN ERROR
- DA EXTENDED BLOCK MOVE
- DC SHUTDOWN 10
- 89 ENABLE NMI
- 90 INIT. HDD CONTROLLER
- 91 INIT. LOCAL BUS HDD CONTROLLER
- 92 JUMP TO USER PATCH 2
- 94 DISABLE A20 ADDRESS LINE
- 96 CLEAR HUGE ES SEGMENT REG.
- 98 SEARCH FOR OPTION ROMS

DRAW	KO, W.S.	DATE	3/15/2007	TITLE	Macao	<b>SAMSUNG</b> ELECTRONICS
CHECK	PARK, H.K.	DEV. STEP	SR	MAIN		
APPROVAL	EUH, J.S.	REV	1.0	FWH & 80port	PART NO.	BA41-00743A
MODULE CODE		LAST EDIT		March 15, 2007 12:01:15 PM	PAGE	20 OF 47

**SAMSUNG PROPRIETARY**

THIS DOCUMENT CONTAINS CONFIDENTIAL PROPRIETARY INFORMATION THAT IS SAMSUNG ELECTRONICS CO.'S PROPERTY. DO NOT DISCLOSE TO OR DUPLICATE FOR OTHERS EXCEPT AS AUTHORIZED BY SAMSUNG.

# RGB Encoder

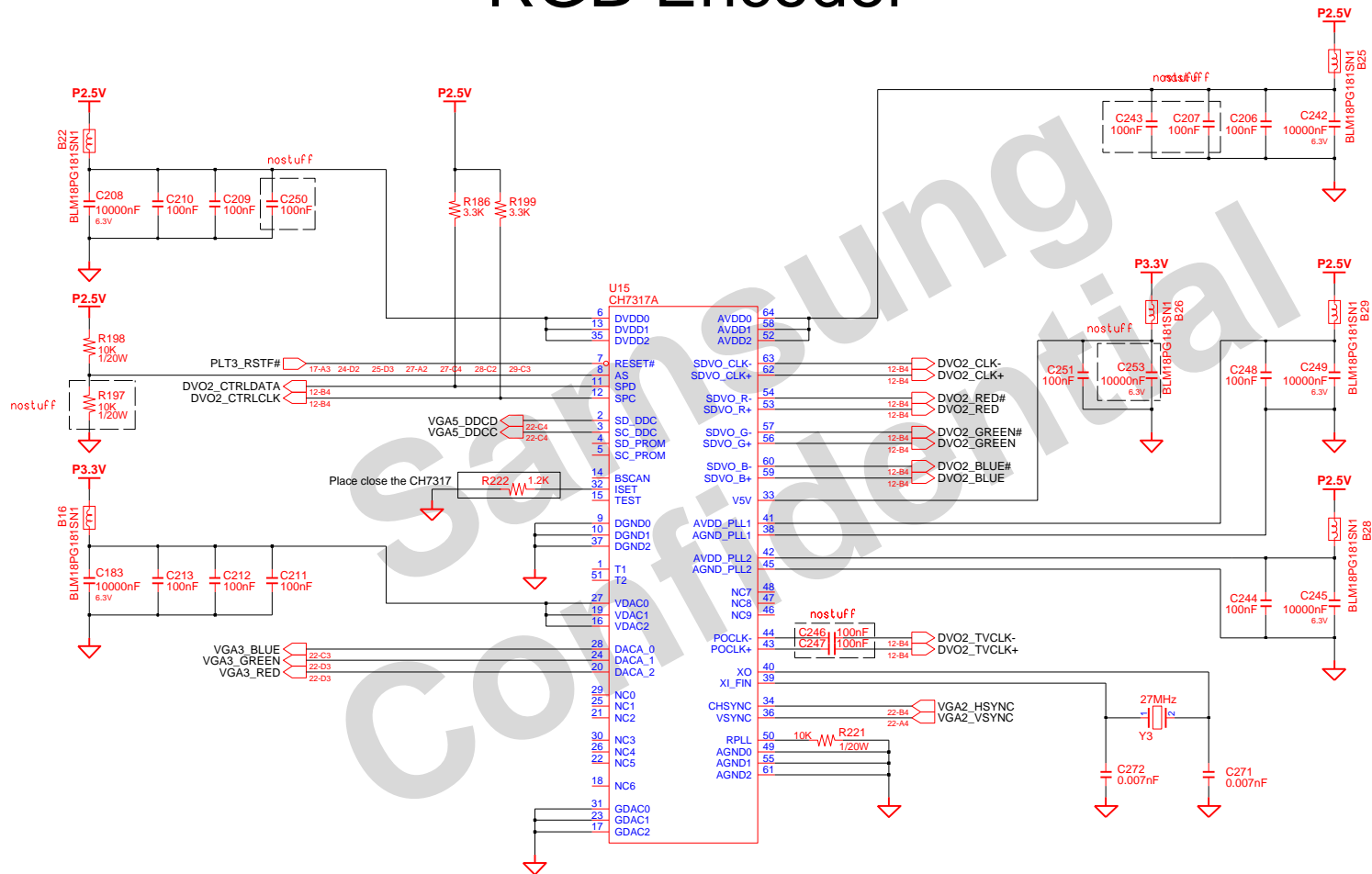

DRAW	KO, W.S.	DATE	3/15/2007	TITLE	Macao	SAMSUNG ELECTRONICS
CHECK	PARK, H.K.	DEV. STEP	SR	MAIN		
APPROVAL	EUH, J.S.	REV	1.0	SDVO to RGB	PART NO.	BA41-00743A
MODULE CODE		LAST EDIT	March 15, 2007 12:01:15 PM	PAGE	21	OF 47

**SAMSUNG PROPRIETARY**

THIS DOCUMENT CONTAINS CONFIDENTIAL PROPRIETARY INFORMATION THAT IS SAMSUNG ELECTRONICS CO.'S PROPERTY. DO NOT DISCLOSE TO OR DUPLICATE FOR OTHERS EXCEPT AS AUTHORIZED BY SAMSUNG.

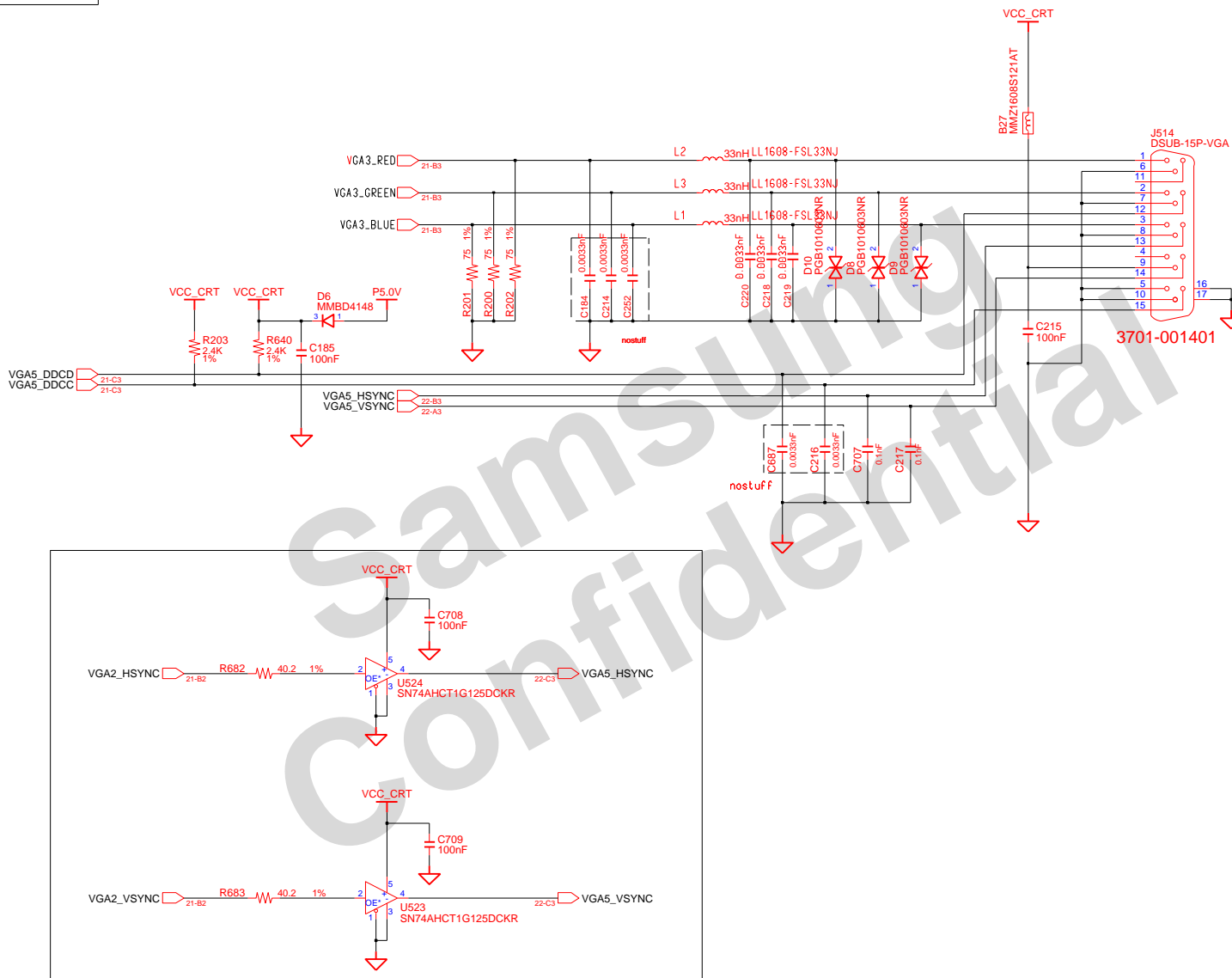

DRAW	KO, W.S.	DATE	3/15/2007	TITLE	Macao	<b>SAMSUNG</b> ELECTRONICS
CHECK	PARK, H.K.	DEV. STEP	SR	MAIN		
APPROVAL	EUH, J.S.	REV	1.0	VGA Conn(CRT)	PART NO.	BA41-00743A
MODULE CODE		LAST EDIT	March 15, 2007 12:01:15 PM	PAGE	22	OF 47

**SAMSUNG PROPRIETARY**

THIS DOCUMENT CONTAINS CONFIDENTIAL PROPRIETARY INFORMATION THAT IS SAMSUNG ELECTRONICS CO.'S PROPERTY. DO NOT DISCLOSE TO OR DUPLICATE FOR OTHERS EXCEPT AS AUTHORIZED BY SAMSUNG.

**TCON Sub B'd**

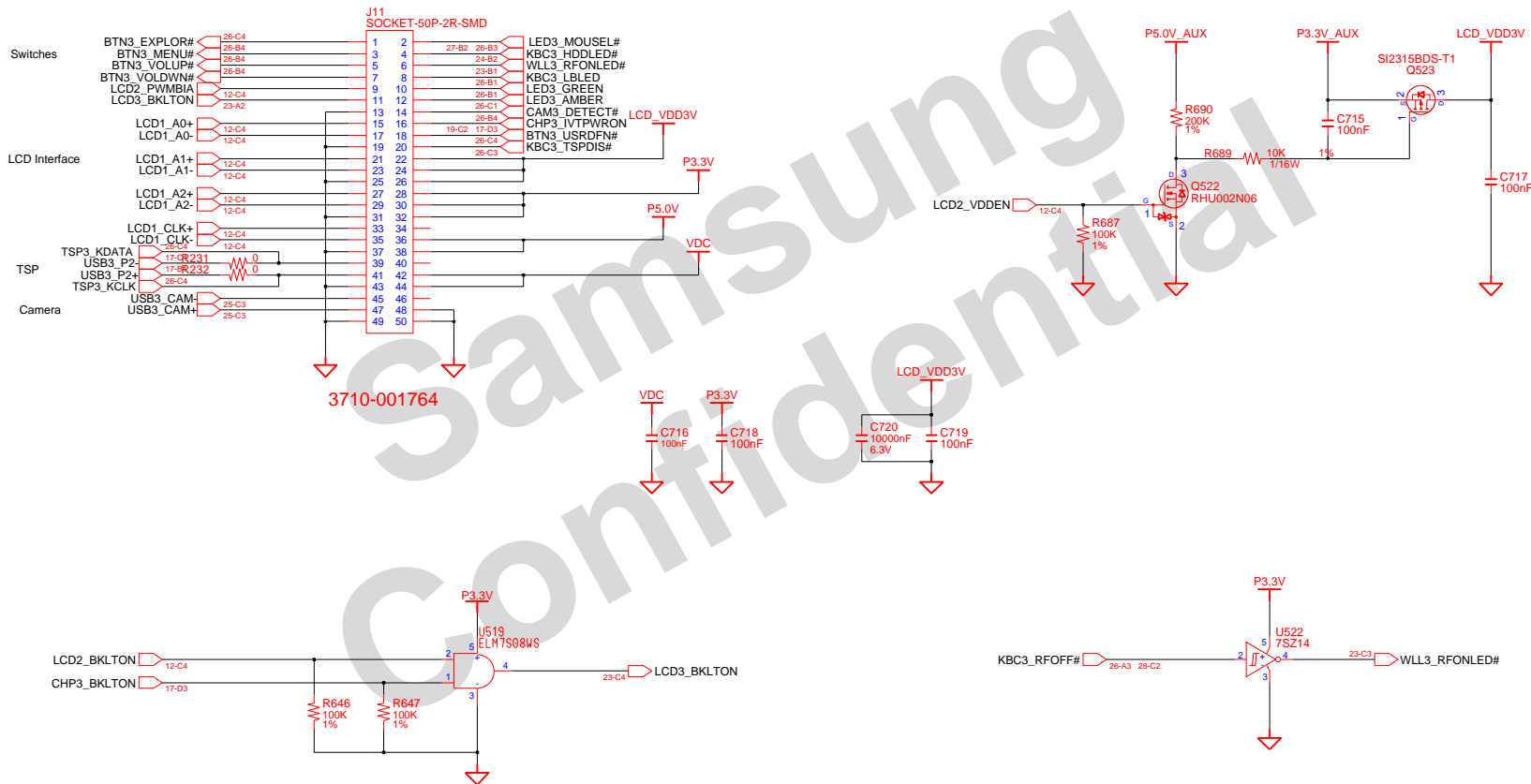

DRAW	KO, W.S.	DATE	3/15/2007	TITLE	Macao	SAMSUNG ELECTRONICS
CHECK	PARK, H.K.	DEV. STEP	SR	MAIN		
APPROVAL	EUH, J.S.	REV	1.0	TCON Sub Conn	PART NO.	BA41-00743A
MODULE CODE		LAST EDIT	March 15, 2007 12:01:15 PM	PAGE	23	OF 47

**SAMSUNG PROPRIETARY**

THIS DOCUMENT CONTAINS CONFIDENTIAL  
 PROPRIETARY INFORMATION THAT IS  
 SAMSUNG ELECTRONICS CO.'S PROPERTY.  
 DO NOT DISCLOSE TO OR DUPLICATE FOR OTHERS  
 EXCEPT AS AUTHORIZED BY SAMSUNG.

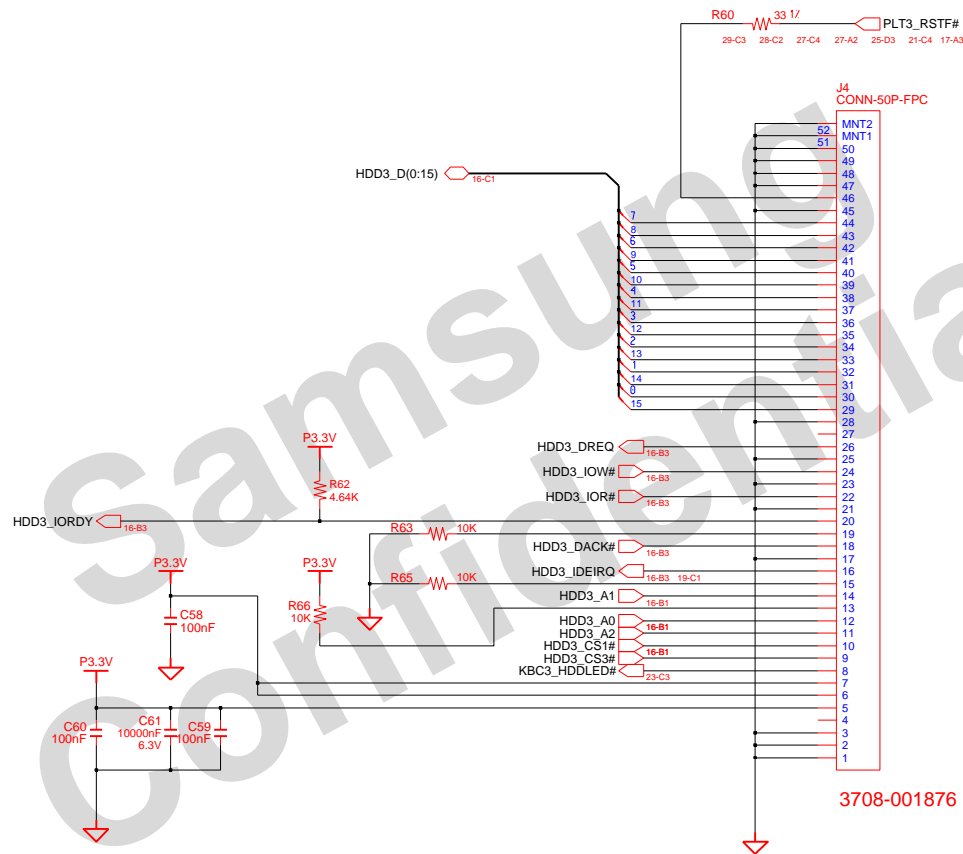

3708-001876

DRAW	KO, W.S.	DATE	3/15/2007	TITLE	Macao	SAMSUNG ELECTRONICS
CHECK	PARK, H.K.	DEV. STEP	SR	MAIN		
APPROVAL	EUH, J.S.	REV	1.0	HDD CONNECTOR	PART NO.	BA41-00743A
MODULE CODE		LAST EDIT	March 15, 2007 12:01:15 PM	PAGE	24	OF 47



**SAMSUNG PROPRIETARY**

THIS DOCUMENT CONTAINS CONFIDENTIAL PROPRIETARY INFORMATION THAT IS SAMSUNG ELECTRONICS CO.'S PROPERTY. DO NOT DISCLOSE TO OR DUPLICATE FOR OTHERS EXCEPT AS AUTHORIZED BY SAMSUNG.

**USB Hub 4 ports + EEPROM**

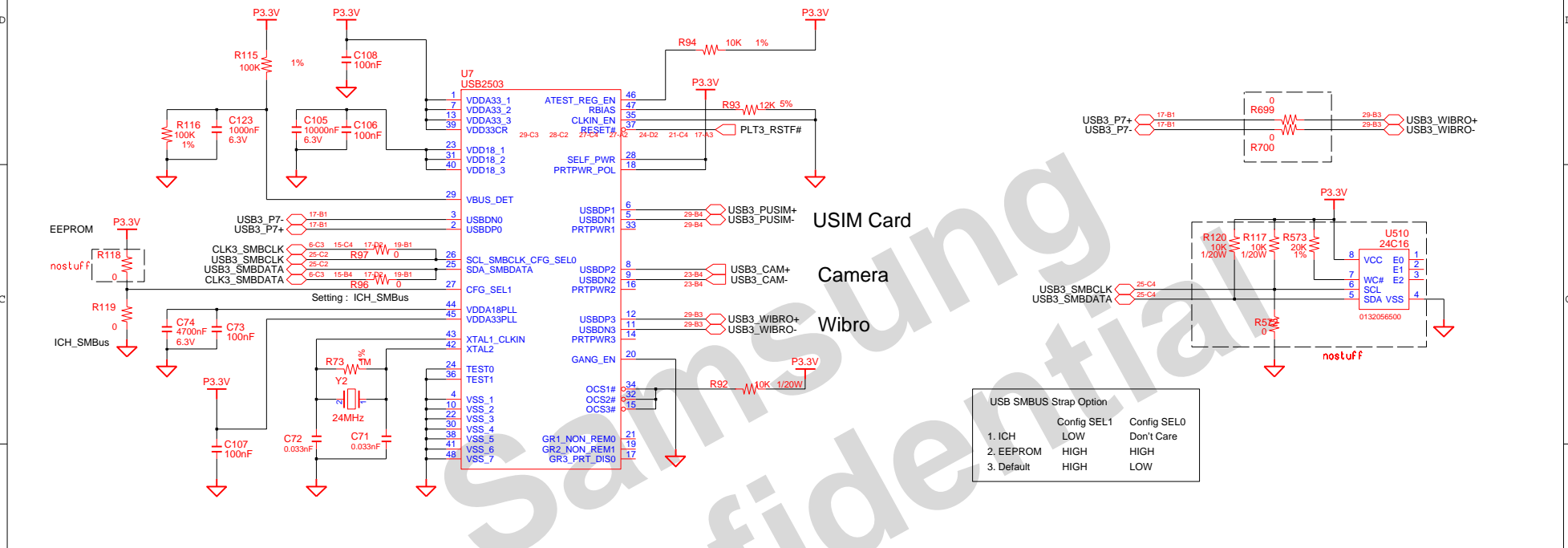

**DMB Connector & Pem(4mm Height)**

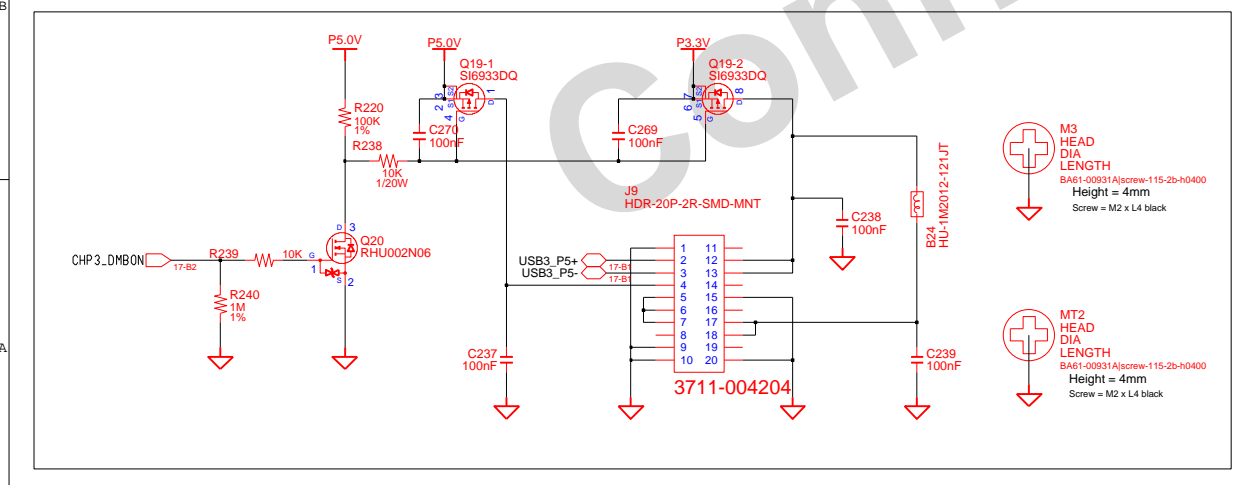

**Right USB Jack (USB PORT 1)**

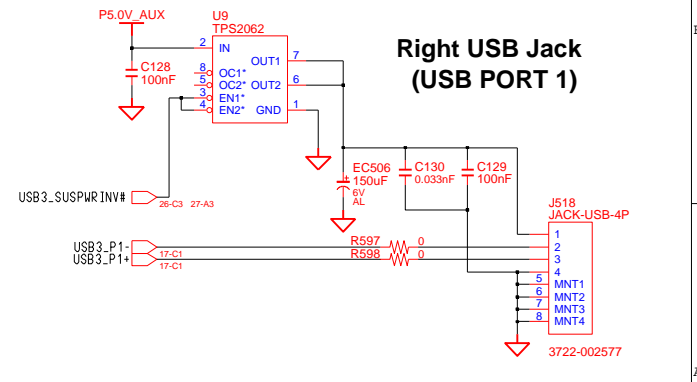

DRAW	K0, W.S.	DATE	3/15/2007	TITLE	Macao	SAMSUNG ELECTRONICS
CHECK	PARK, H.K.	DEV. STEP	SR	MAIN	PART NO.	
APPROVAL	EUH, J.S.	REV	1.0	USB & DMB	BA41-00743A	PAGE 25 OF 47
MODULE CODE		LAST EDIT	March 15, 2007 12:01:15 PM			

**SAMSUNG PROPRIETARY**

THIS DOCUMENT CONTAINS CONFIDENTIAL PROPRIETARY INFORMATION THAT IS SAMSUNG ELECTRONICS CO.'S PROPERTY. DO NOT DISCLOSE TO OR DUPLICATE FOR OTHERS EXCEPT AS AUTHORIZED BY SAMSUNG.

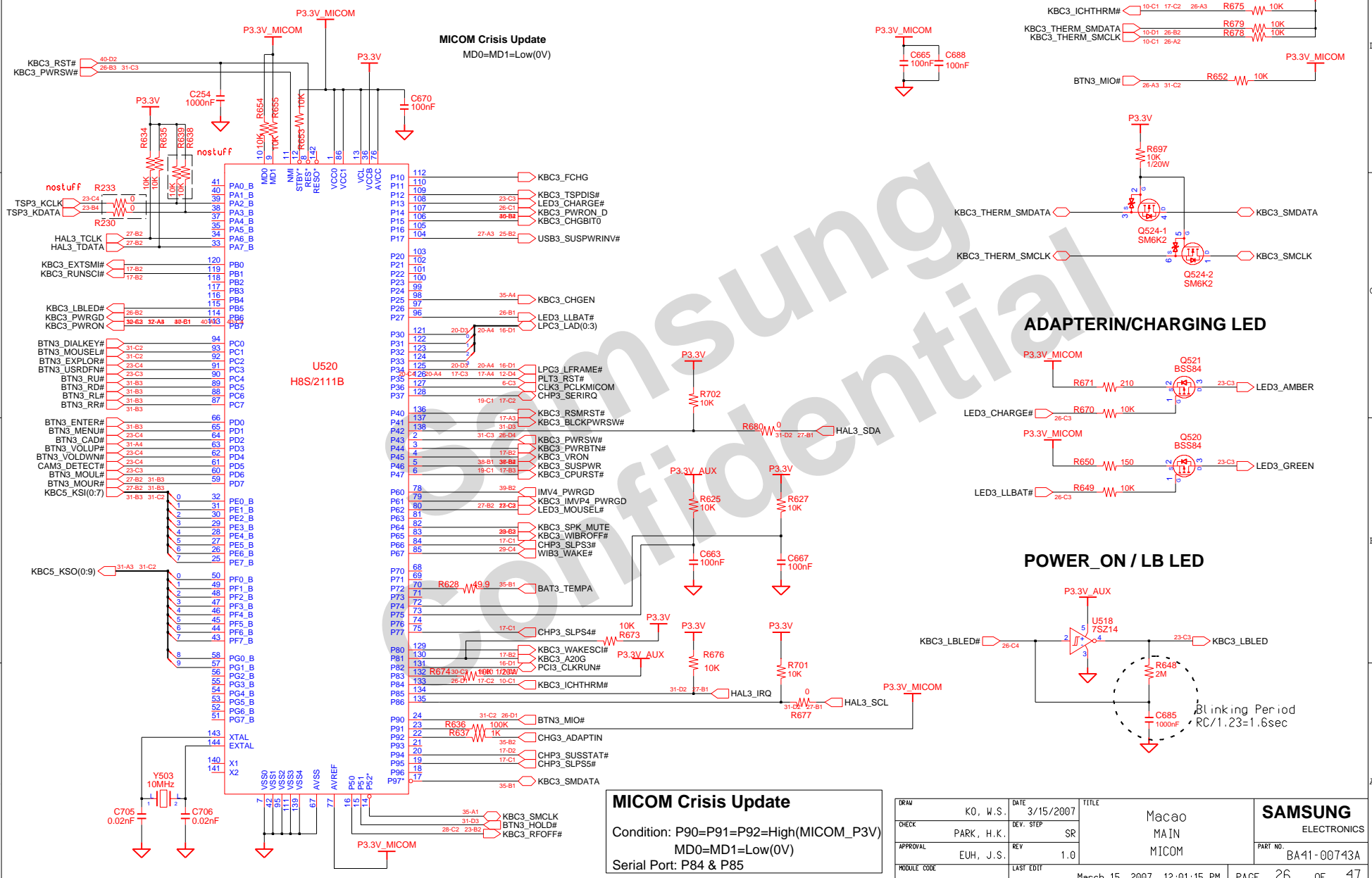

DRAW	K0, W.S.	DATE	3/15/2007	TITLE	Macao	<b>SAMSUNG</b> ELECTRONICS
CHECK	PARK, H.K.	DEV. STEP	SR	MAIN	PART NO.	
APPROVAL	EUH, J.S.	REV	1.0	MICOM	BA41-00743A	
MODULE CODE		LAST EDIT	March 15, 2007 12:01:15 PM	PAGE	26	OF 47

**SAMSUNG PROPRIETARY**

THIS DOCUMENT CONTAINS CONFIDENTIAL PROPRIETARY INFORMATION THAT IS SAMSUNG ELECTRONICS CO.'S PROPERTY. DO NOT DISCLOSE TO OR DUPLICATE FOR OTHERS EXCEPT AS AUTHORIZED BY SAMSUNG.

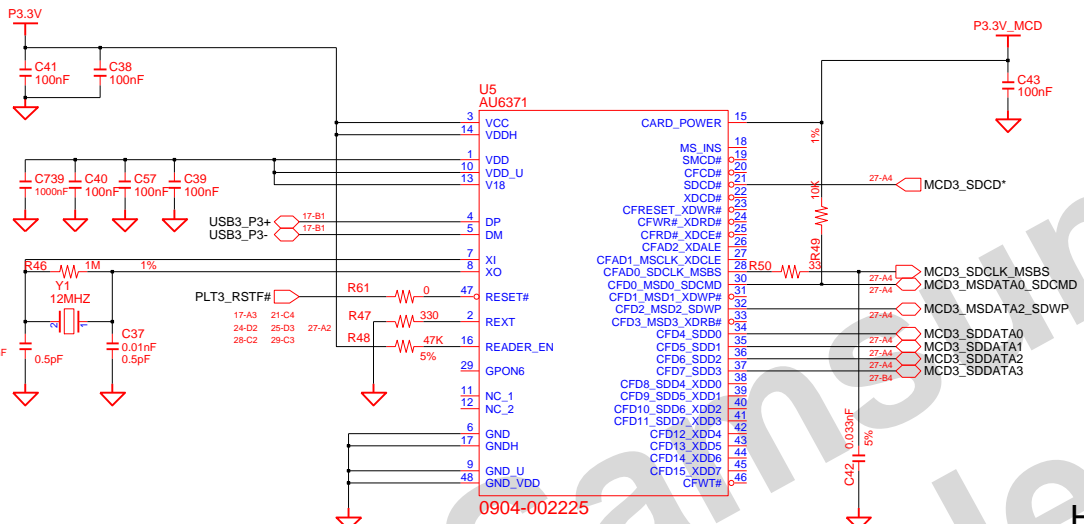

**Hall Mouse IC (I2C to PS2 Conversion IC)**

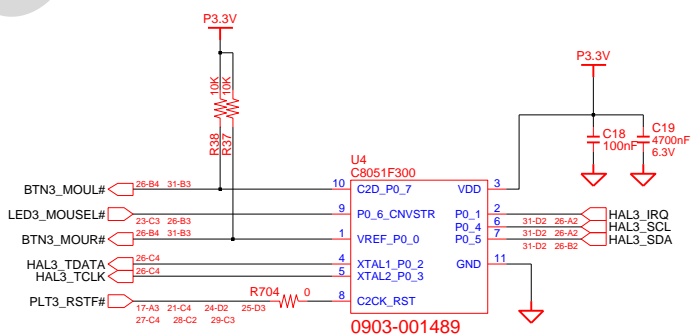
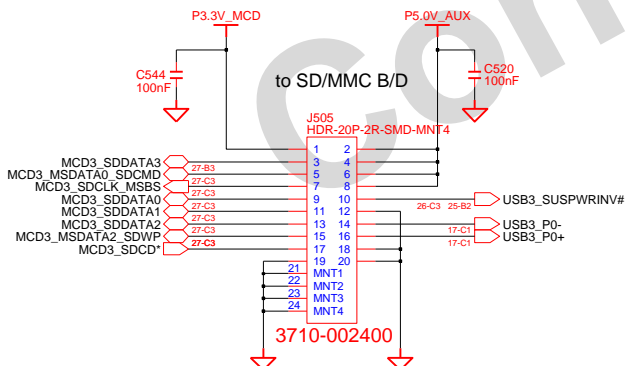

DRAW	KO, W.S.	DATE	3/15/2007	TITLE	Macao	<b>SAMSUNG</b> ELECTRONICS
CHECK	PARK, H.K.	DEV. STEP	SR	MAIN		
APPROVAL	EUH, J.S.	REV	1.0	SD/MMC Controller		PART NO. BA41-00743A
MODULE CODE		LAST EDIT	March 15, 2007 12:01:15 PM		PAGE	27 OF 47

**SAMSUNG PROPRIETARY**

THIS DOCUMENT CONTAINS CONFIDENTIAL PROPRIETARY INFORMATION THAT IS SAMSUNG ELECTRONICS CO.'S PROPERTY. DO NOT DISCLOSE TO OR DUPLICATE FOR OTHERS EXCEPT AS AUTHORIZED BY SAMSUNG.

# WirelessLAN ( PCI-E 1x )

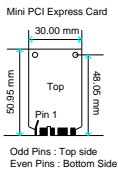
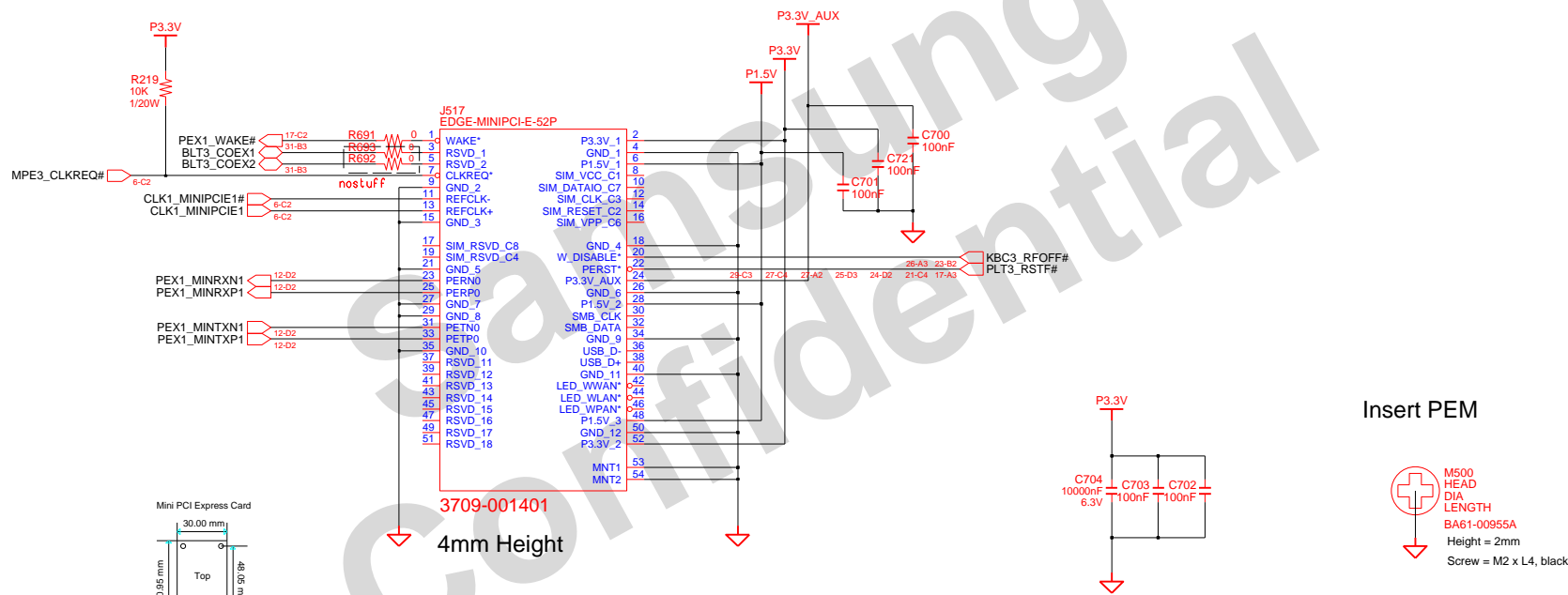

**Mini PCI Express**

PCI Express Mini Card ElectroMechanical Spec. 1.0

DRAW	KO, W.S.	DATE	3/15/2007	TITLE	Macao	<b>SAMSUNG</b> ELECTRONICS
CHECK	PARK, H.K.	DEV. STEP	SR	MAIN		
APPROVAL	EUH, J.S.	REV	1.0	WirelessLAN	PART NO.	BA41-00743A
MODULE CODE		LAST EDIT	March 15, 2007 12:01:15 PM	PAGE	28	OF 47

**SAMSUNG PROPRIETARY**

THIS DOCUMENT CONTAINS CONFIDENTIAL PROPRIETARY INFORMATION THAT IS SAMSUNG ELECTRONICS CO.'S PROPERTY. DO NOT DISCLOSE TO OR DUPLICATE FOR OTHERS EXCEPT AS AUTHORIZED BY SAMSUNG.

# Wibro / HSDPA ( USB 4 )

## Wibro Socket

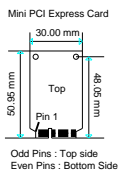
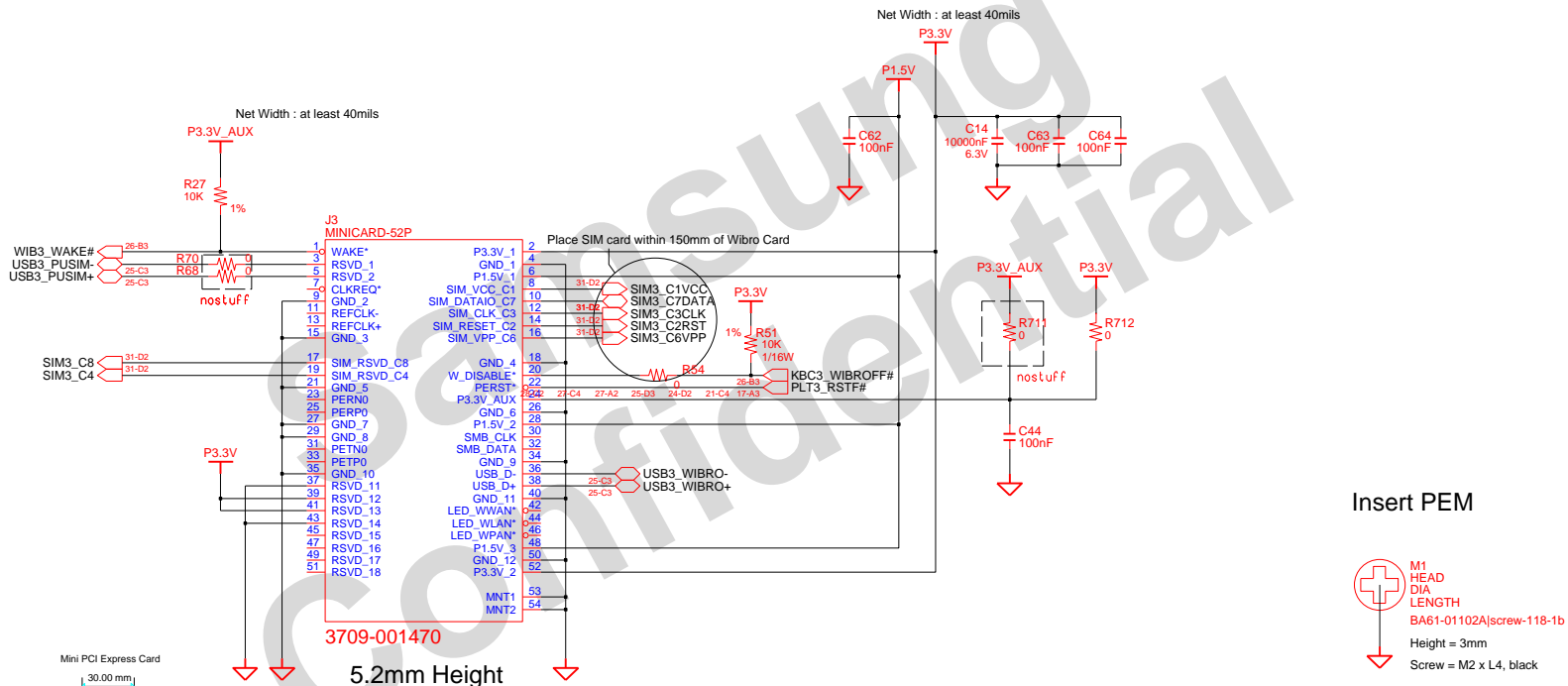

**Mini Card (Socket Only)**

PCI Express Mini Card ElectroMechanical Spec. 1.0

DRAW	KO, W.S.	DATE	3/15/2007	TITLE	Macao	SAMSUNG ELECTRONICS
CHECK	PARK, H.K.	DEV. STEP	SR	MAIN		
APPROVAL	EUH, J.S.	REV	1.0	Wibro/HSDPA	PART NO.	BA41-00743A
MODULE CODE		LAST EDIT	March 15, 2007 12:01:15 PM	PAGE	29	OF 47

**SAMSUNG PROPRIETARY**

THIS DOCUMENT CONTAINS CONFIDENTIAL  
 PROPRIETARY INFORMATION THAT IS  
 SAMSUNG ELECTRONICS CO.'S PROPERTY.  
 DO NOT DISCLOSE TO OR DUPLICATE FOR OTHERS  
 EXCEPT AS AUTHORIZED BY SAMSUNG.

# Wired LAN : 60p Conn

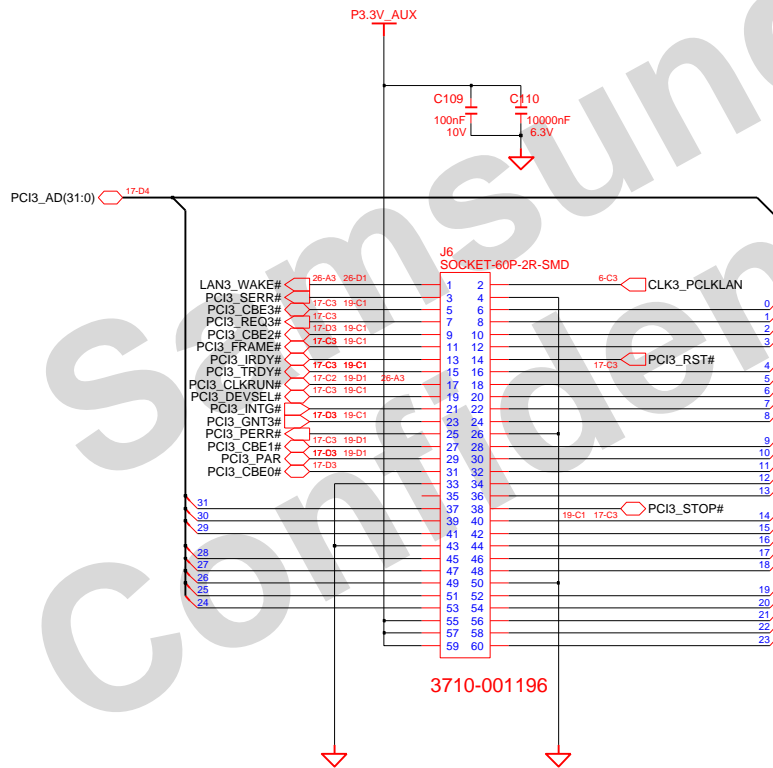

DRAW	KO, W.S.	DATE	3/15/2007	TITLE	Macao	SAMSUNG ELECTRONICS
CHECK	PARK, H.K.	DEV. STEP	SR	MAIN		
APPROVAL	EUH, J.S.	REV	1.0	Wired LAN Conn	PART NO.	BA41-00743A
MODULE CODE		LAST EDIT	March 15, 2007 12:01:15 PM	PAGE	30	OF 47

**SAMSUNG PROPRIETARY**

THIS DOCUMENT CONTAINS CONFIDENTIAL PROPRIETARY INFORMATION THAT IS SAMSUNG ELECTRONICS CO.'S PROPERTY. DO NOT DISCLOSE TO OR DUPLICATE FOR OTHERS EXCEPT AS AUTHORIZED BY SAMSUNG.

**Main to Subboard(Left)**

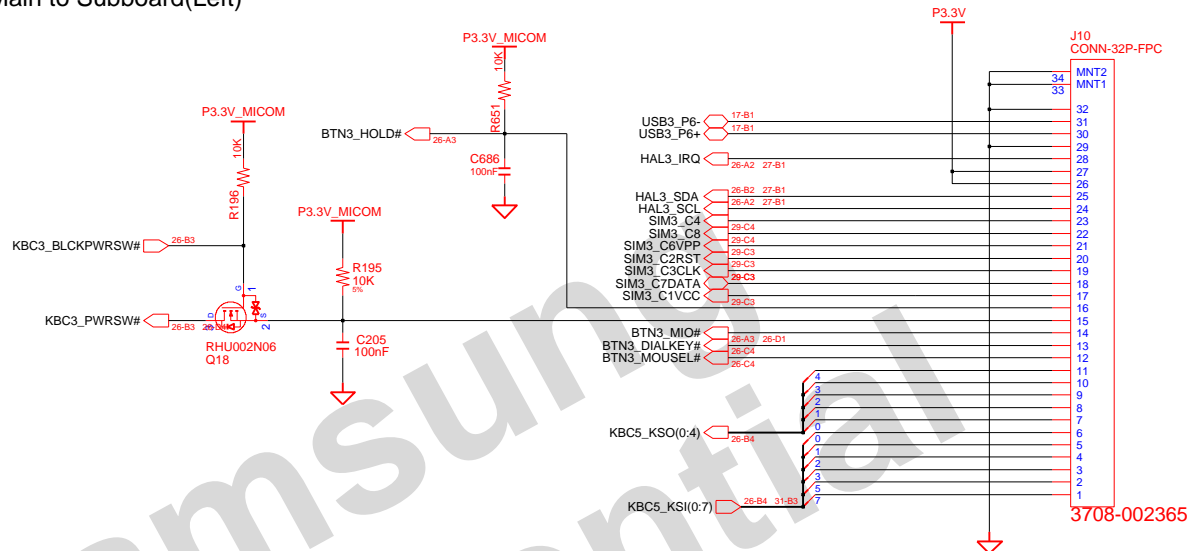

**Main to Subboard(Right)**

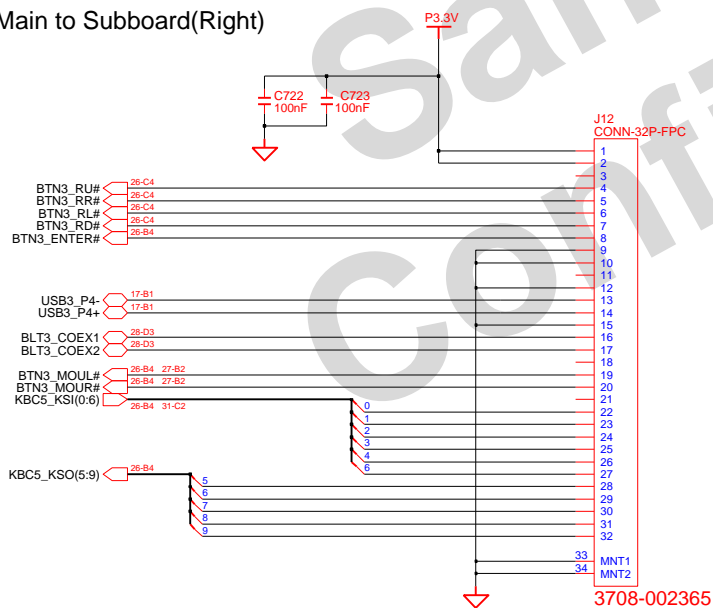

**Ctrl\_Alt\_Del Button**

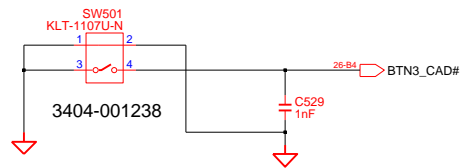

DRAW	KO, W.S.	DATE	3/15/2007	TITLE	Macao	SAMSUNG ELECTRONICS
CHECK	PARK, H.K.	DEV. STEP	SR	MAIN		
APPROVAL	EUH, J.S.	REV	1.0	SUB B'D Conn. & S/W	PART NO.	BA41-00743A
MODULE CODE		LAST EDIT	March 15, 2007 12:01:15 PM	PAGE	31	OF 47

**SAMSUNG PROPRIETARY**

THIS DOCUMENT CONTAINS CONFIDENTIAL PROPRIETARY INFORMATION THAT IS SAMSUNG ELECTRONICS CO.'S PROPERTY. DO NOT DISCLOSE TO OR DUPLICATE FOR OTHERS EXCEPT AS AUTHORIZED BY SAMSUNG.

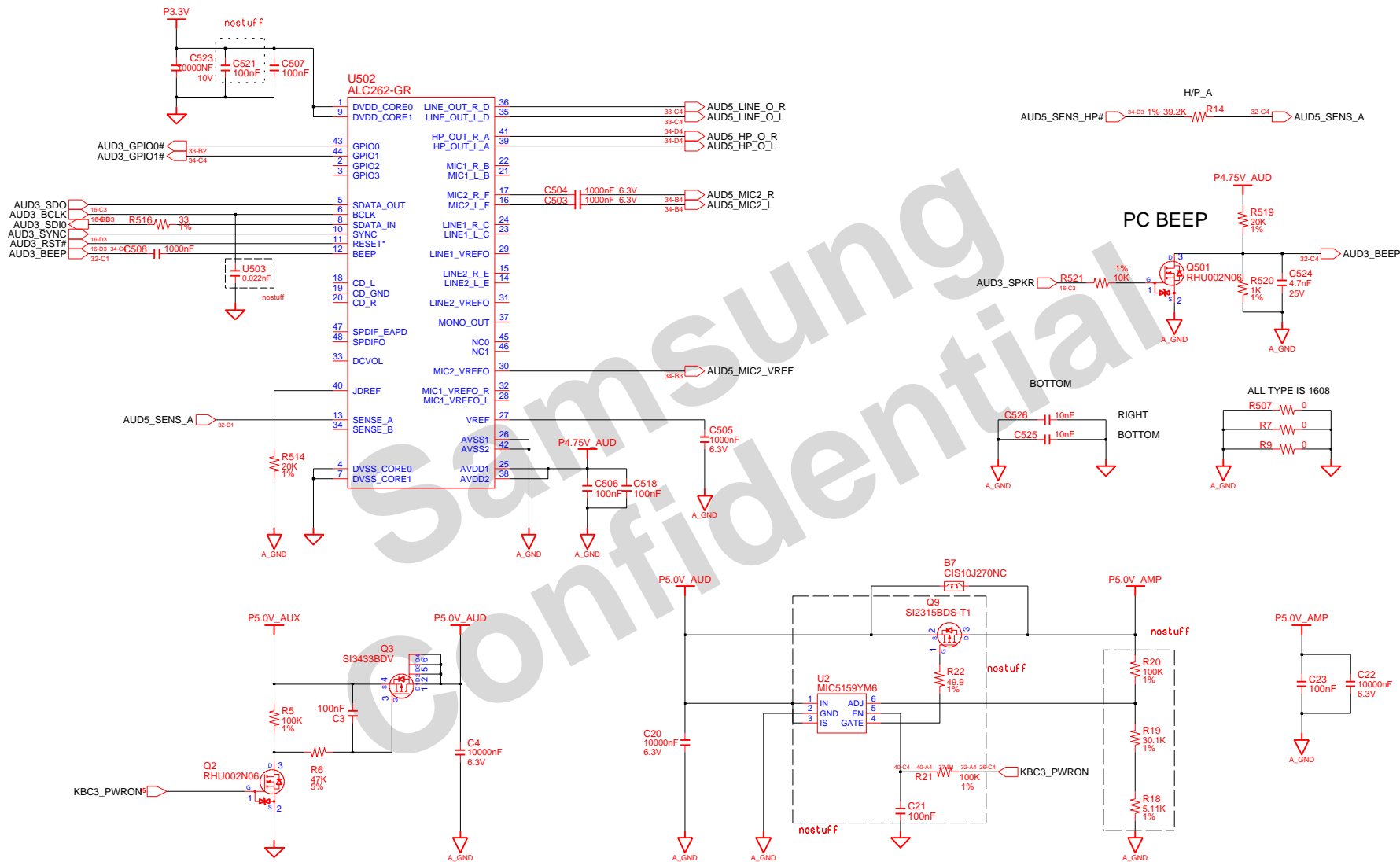

DRAW	KO, W.S.	DATE	3/15/2007	TITLE	Macao MAIN	SAMSUNG ELECTRONICS
CHECK	PARK, H.K.	DEV. STEP	SR			
APPROVAL	EUH, J.S.	REV	1.0		Audio Codec	PART NO. BA41-00743A
MODULE CODE		LAST EDIT		March 15, 2007 12:01:15 PM	PAGE	32 OF 47



**SAMSUNG PROPRIETARY**

THIS DOCUMENT CONTAINS CONFIDENTIAL PROPRIETARY INFORMATION THAT IS SAMSUNG ELECTRONICS CO.'S PROPERTY. DO NOT DISCLOSE TO OR DUPLICATE FOR OTHERS EXCEPT AS AUTHORIZED BY SAMSUNG.

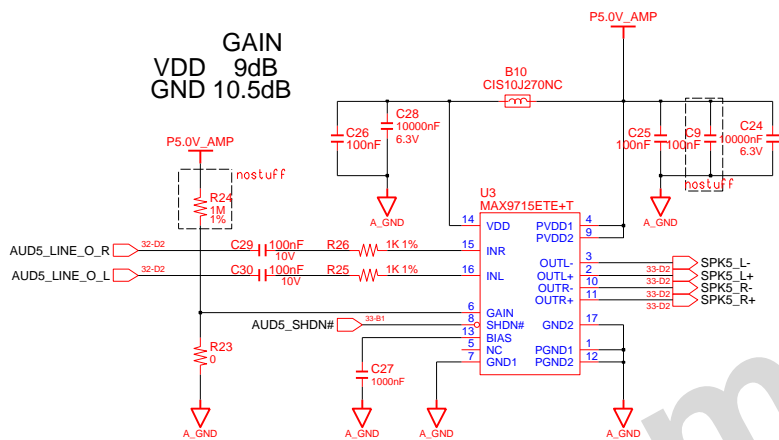

**INTERNAL STEREO SPEAKERS**

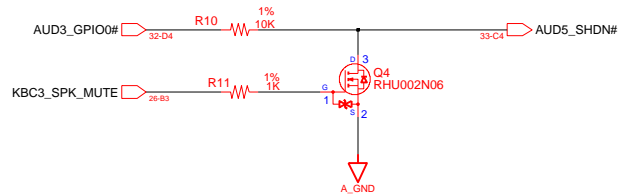
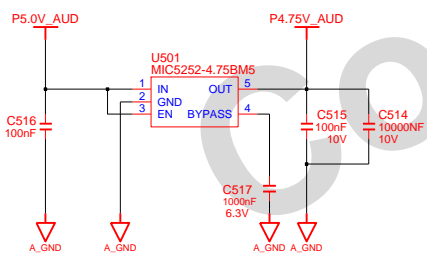
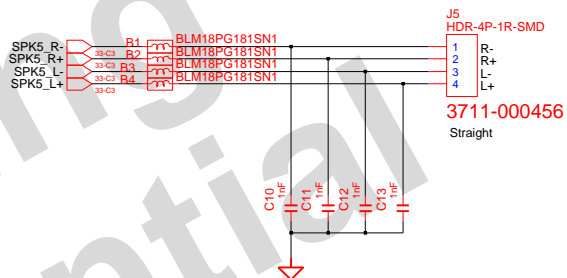

DRAW	KO, W.S.	DATE	3/15/2007	TITLE	Macao MAIN AMP & Spkr Conn	<b>SAMSUNG</b> ELECTRONICS PART NO. BA41-00743A
CHECK	PARK, H.K.	DEV. STEP	SR			
APPROVAL	EUH, J.S.	REV	1.0			
MODULE CODE		LAST EDIT	March 15, 2007 12:01:15 PM	PAGE	33 OF 47	

**SAMSUNG PROPRIETARY**

THIS DOCUMENT CONTAINS CONFIDENTIAL PROPRIETARY INFORMATION THAT IS SAMSUNG ELECTRONICS CO.'S PROPERTY. DO NOT DISCLOSE TO OR DUPLICATE FOR OTHERS EXCEPT AS AUTHORIZED BY SAMSUNG.

**HEADPHONE**

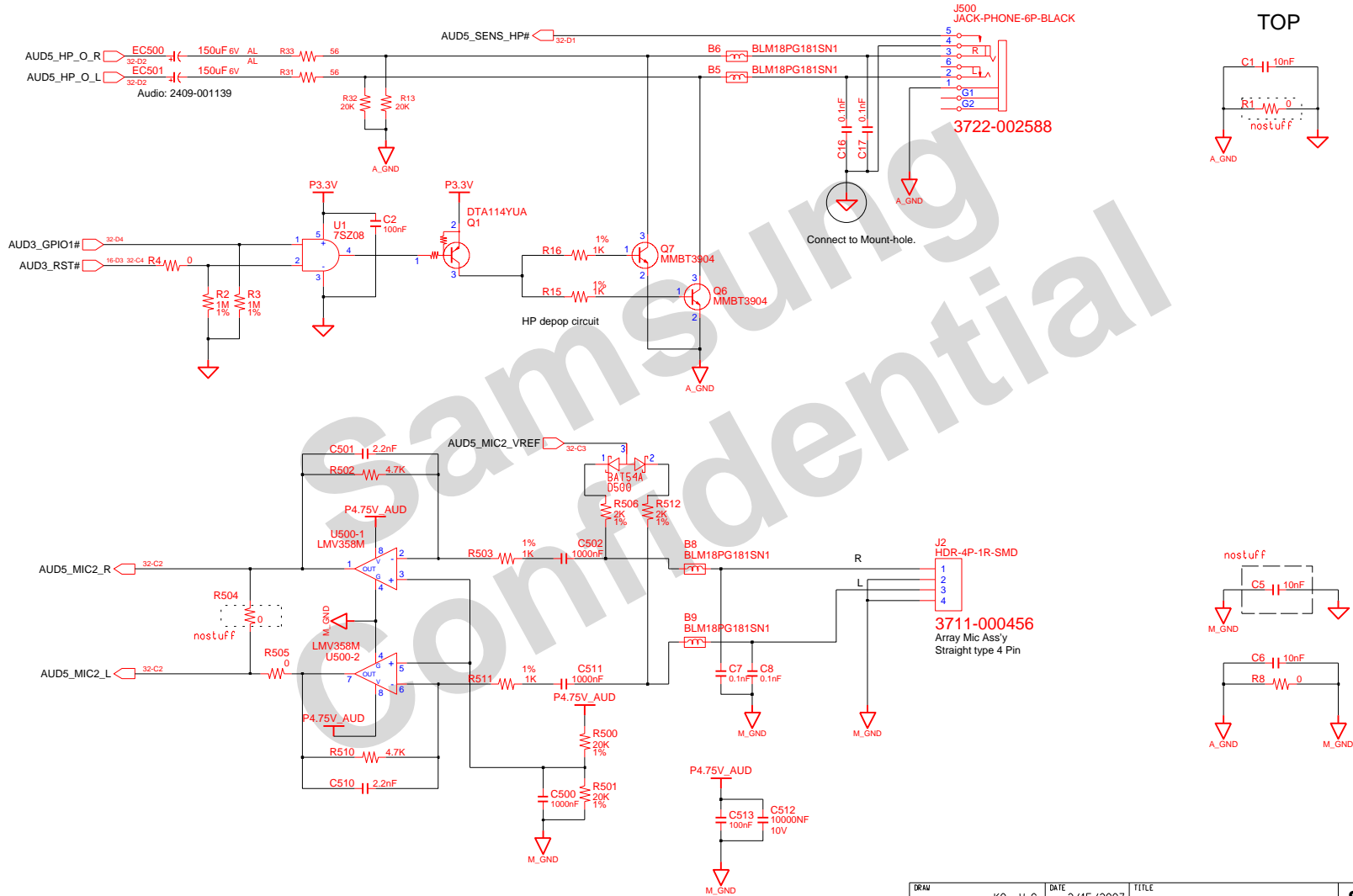

**TOP**

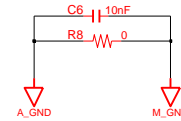
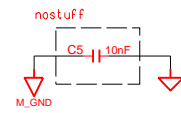
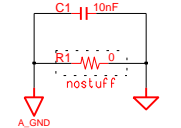

DRAW	KO, W.S.	DATE	3/15/2007	TITLE	Macao	SAMSUNG ELECTRONICS
CHECK	PARK, H.K.	DEV. STEP	SR	MAIN	PART NO.	
APPROVAL	EUH, J.S.	REV	1.0	Phone Jack & MIC	BA41-00743A	
MODULE CODE		LAST EDIT	March 15, 2007 12:01:15 PM	PAGE	34	OF 47

**SAMSUNG PROPRIETARY**

THIS DOCUMENT CONTAINS CONFIDENTIAL PROPRIETARY INFORMATION THAT IS SAMSUNG ELECTRONICS CO.'S PROPERTY. DO NOT DISCLOSE TO OR DUPLICATE FOR OTHERS EXCEPT AS AUTHORIZED BY SAMSUNG.

# CHARGER & POWER MANAGEMENT

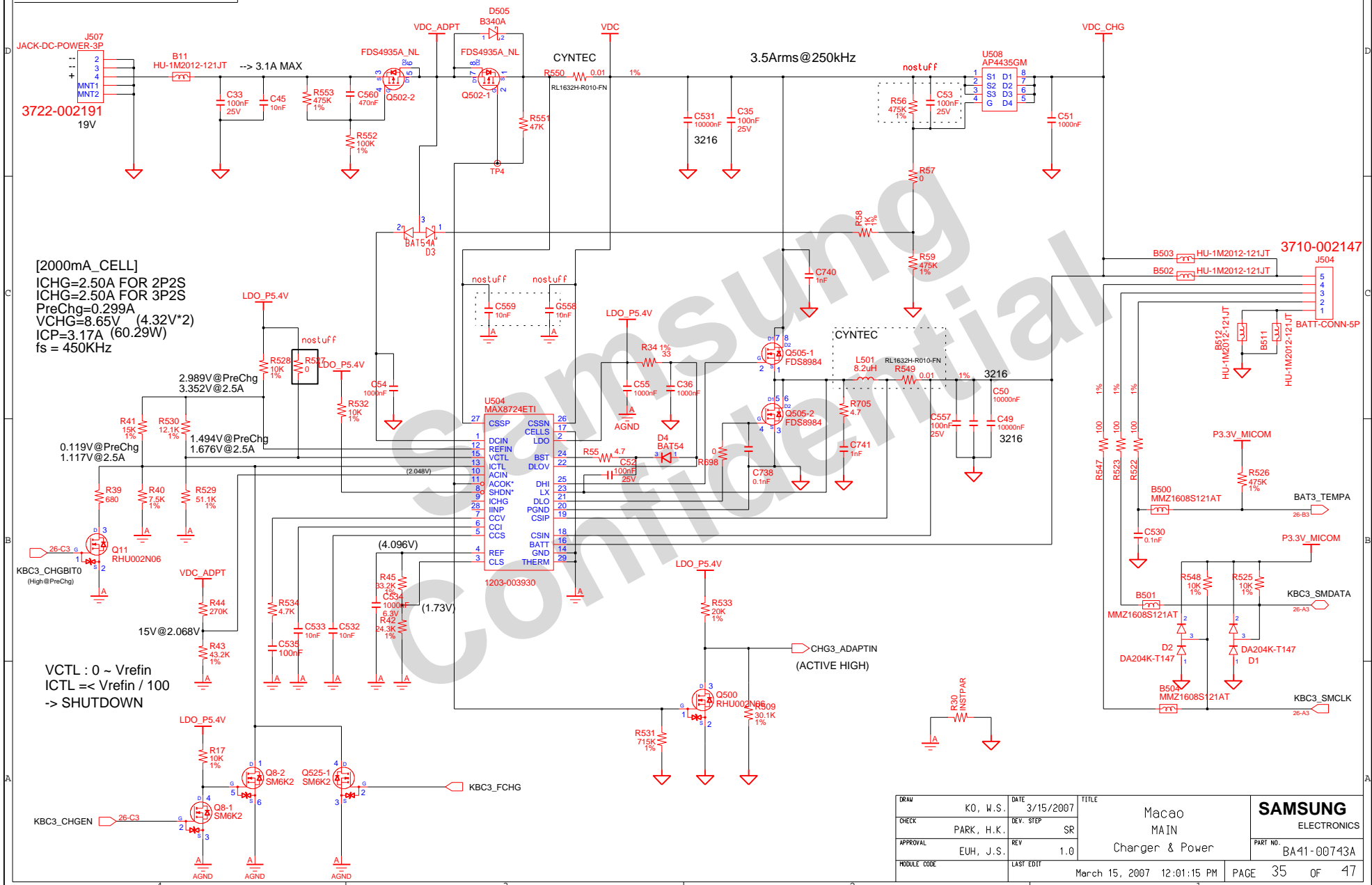

[2000mA\_CELL]  
 ICHG=2.50A FOR 2P2S  
 ICHG=2.50A FOR 3P2S  
 PreChg=0.299A  
 VCHG=8.65V (4.32V\*2)  
 ICP=3.17A (60.29W)  
 fs = 450KHz

2.989V@PreChg  
 3.352V@2.5A  
 1.494V@PreChg  
 1.676V@2.5A

VCTL : 0 ~ Vrefin  
 ICTL =< Vrefin / 100  
 -> SHUTDOWN

KBC3\_CHGEN

DRAW	KO, W.S.	DATE	3/15/2007	TITLE	Macao	SAMSUNG ELECTRONICS
CHECK	PARK, H.K.	DEV. STEP	SR	MAIN	PART NO.	
APPROVAL	EUH, J.S.	REV	1.0	Charger & Power	BA41-00743A	
MODULE CODE		LAST EDIT	March 15, 2007 12:01:15 PM	PAGE	35	OF 47

**SAMSUNG PROPRIETARY**

THIS DOCUMENT CONTAINS CONFIDENTIAL PROPRIETARY INFORMATION THAT IS SAMSUNG ELECTRONICS CO.'S PROPERTY. DO NOT DISCLOSE TO OR DUPLICATE FOR OTHERS EXCEPT AS AUTHORIZED BY SAMSUNG.

# P3.3V\_AUX & P5V\_AUX & P3.3V\_MICOM

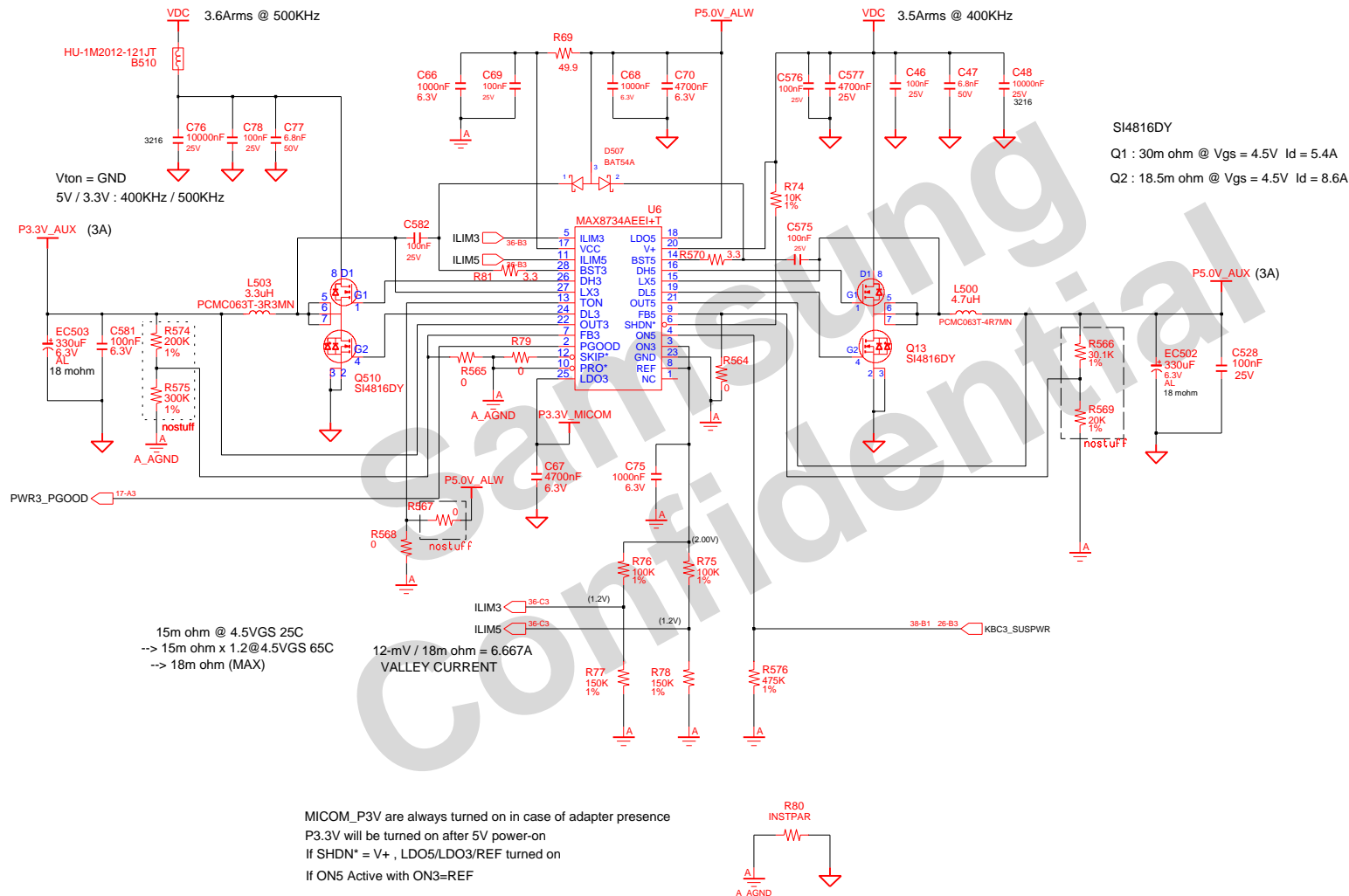

SI4816DY  
 Q1 : 30m ohm @ Vgs = 4.5V Id = 5.4A  
 Q2 : 18.5m ohm @ Vgs = 4.5V Id = 8.6A

Vton = GND  
 5V / 3.3V : 400KHz / 500KHz

15m ohm @ 4.5VGS 25C  
 --> 15m ohm x 1.2@4.5VGS 65C  
 --> 18m ohm (MAX)

12-mV / 18m ohm = 6.667A  
 VALLEY CURRENT

MICOM\_P3V are always turned on in case of adapter presence  
 P3.3V will be turned on after 5V power-on  
 If SHDN\* = V+ , LDO5/LDO3/REF turned on  
 If ON5 Active with ON3=REF

DRAW	KO, W.S.	DATE	3/15/2007	TITLE	Macao	SAMSUNG ELECTRONICS
CHECK	PARK, H.K.	DEV. STEP	SR	MAIN		
APPROVAL	EUH, J.S.	REV	P3	P3V_AUX & P5V_AUX & MICOM_P3V	DRY NO. BA41-00743A	
MODULE CODE		LAST EDIT	March 15, 2007 12:01:15 PM	PAGE	36	OF 47

**SAMSUNG PROPRIETARY**

THIS DOCUMENT CONTAINS CONFIDENTIAL PROPRIETARY INFORMATION THAT IS SAMSUNG ELECTRONICS CO.'S PROPERTY. DO NOT DISCLOSE TO OR DUPLICATE FOR OTHERS EXCEPT AS AUTHORIZED BY SAMSUNG.

# P1.5V & VCCP\_CORE

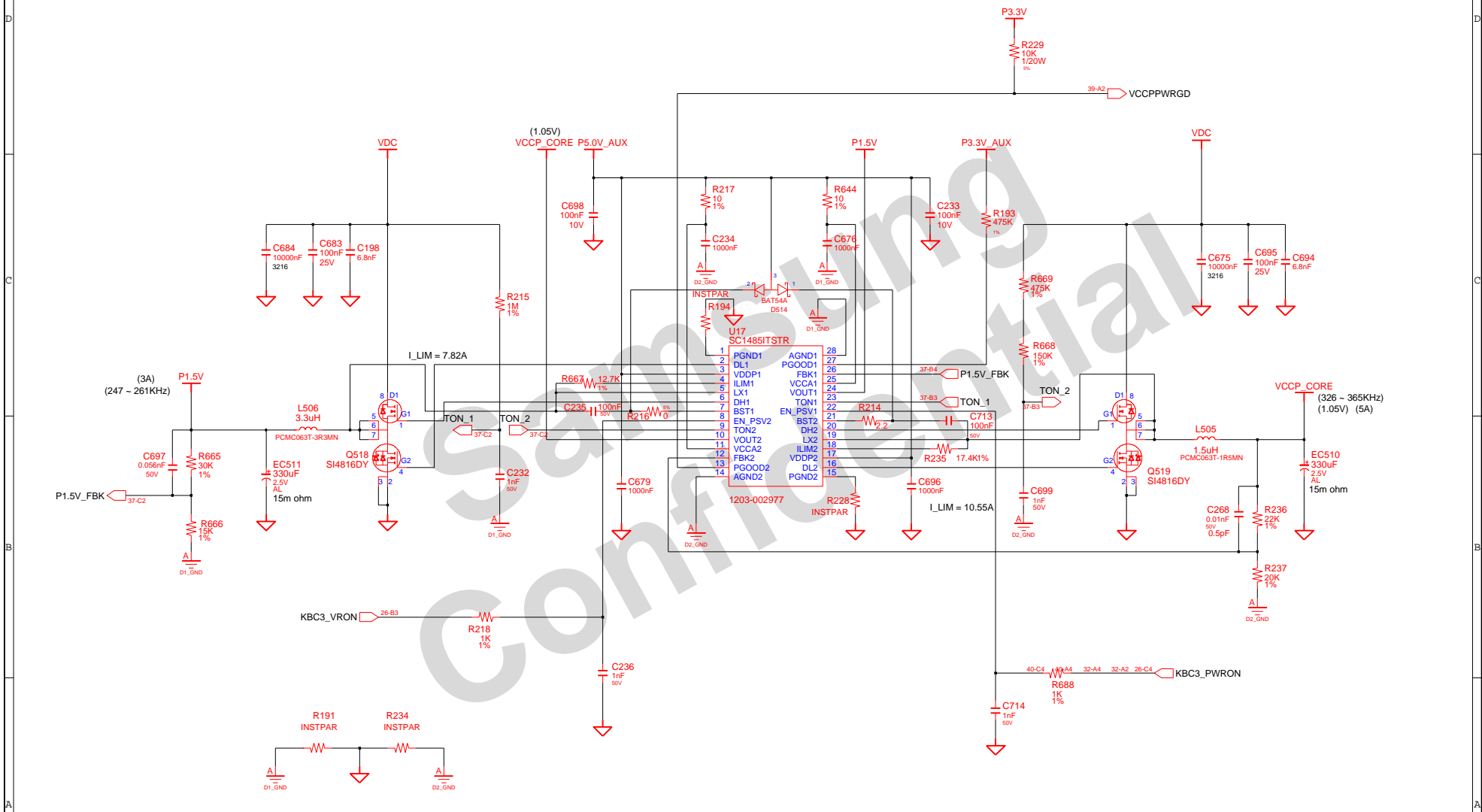

DRAW	KO, W.S.	DATE	3/15/2007	TITLE	Macao	SAMSUNG ELECTRONICS
CHECK	PARK, H.K.	DEV. STEP	SR	MAIN		
APPROVAL	EUH, J.S.	REV	1.0	P1.5V & VCCP	PART NO.	BA41-00743A
MODULE CODE		LAST EDIT	March 15, 2007 12:01:15 PM	PAGE	37	OF 47

**SAMSUNG PROPRIETARY**

THIS DOCUMENT CONTAINS CONFIDENTIAL PROPRIETARY INFORMATION THAT IS SAMSUNG ELECTRONICS CO.'S PROPERTY. DO NOT DISCLOSE TO OR DUPLICATE FOR OTHERS EXCEPT AS AUTHORIZED BY SAMSUNG.

# DDR2 POWER

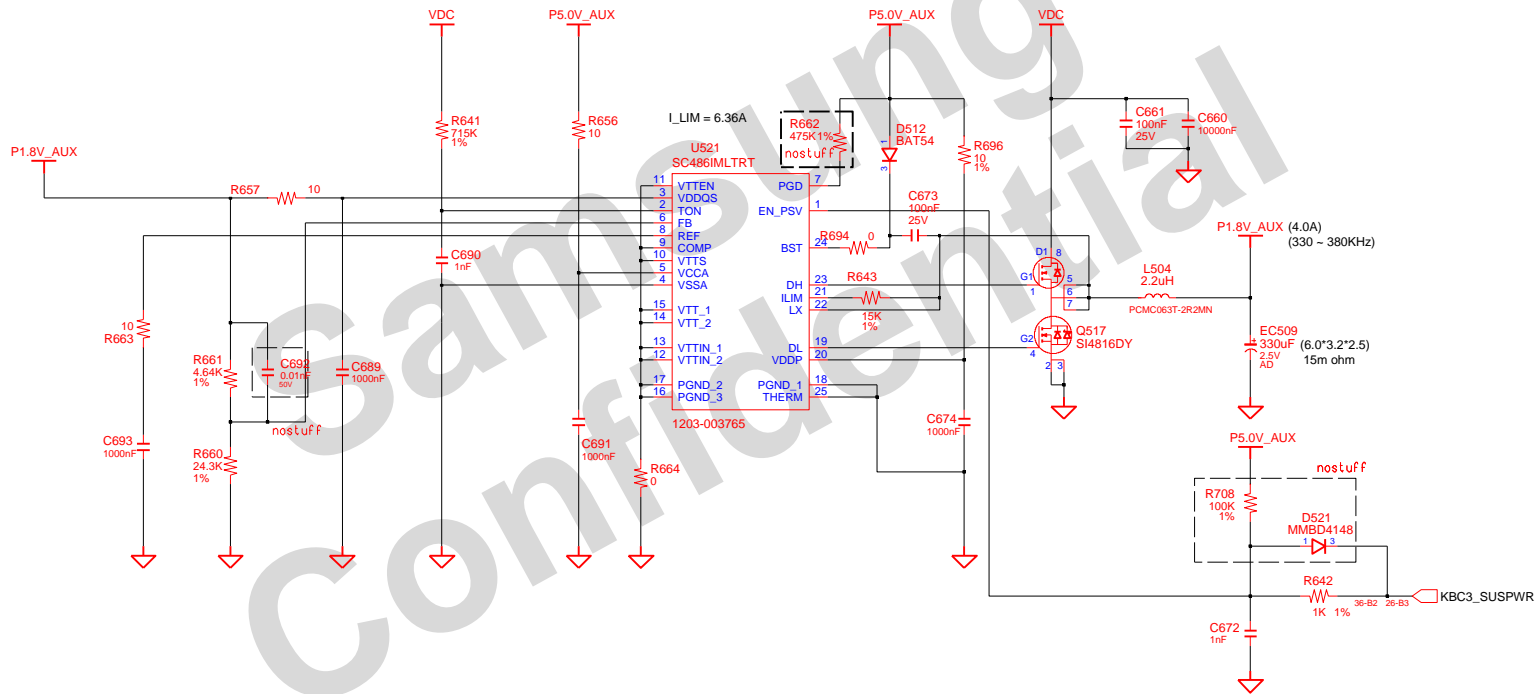

DRAW	KO, W.S.	DATE	3/15/2007	TITLE	Macao	SAMSUNG ELECTRONICS
CHECK	PARK, H.K.	DEV. STEP	SR	MAIN		
APPROVAL	EUH, J.S.	REV	1.0	DDR2 Power	PART NO.	BA41-00743A
MODULE CODE		LAST EDIT	March 15, 2007 12:01:15 PM	PAGE	38	OF 47

**SAMSUNG PROPRIETARY**

THIS DOCUMENT CONTAINS CONFIDENTIAL  
 PROPRIETARY INFORMATION THAT IS  
 SAMSUNG ELECTRONICS CO.'S PROPERTY.  
 DO NOT DISCLOSE TO OR DUPLICATE FOR OTHERS  
 EXCEPT AS AUTHORIZED BY SAMSUNG.

# CPU VRM

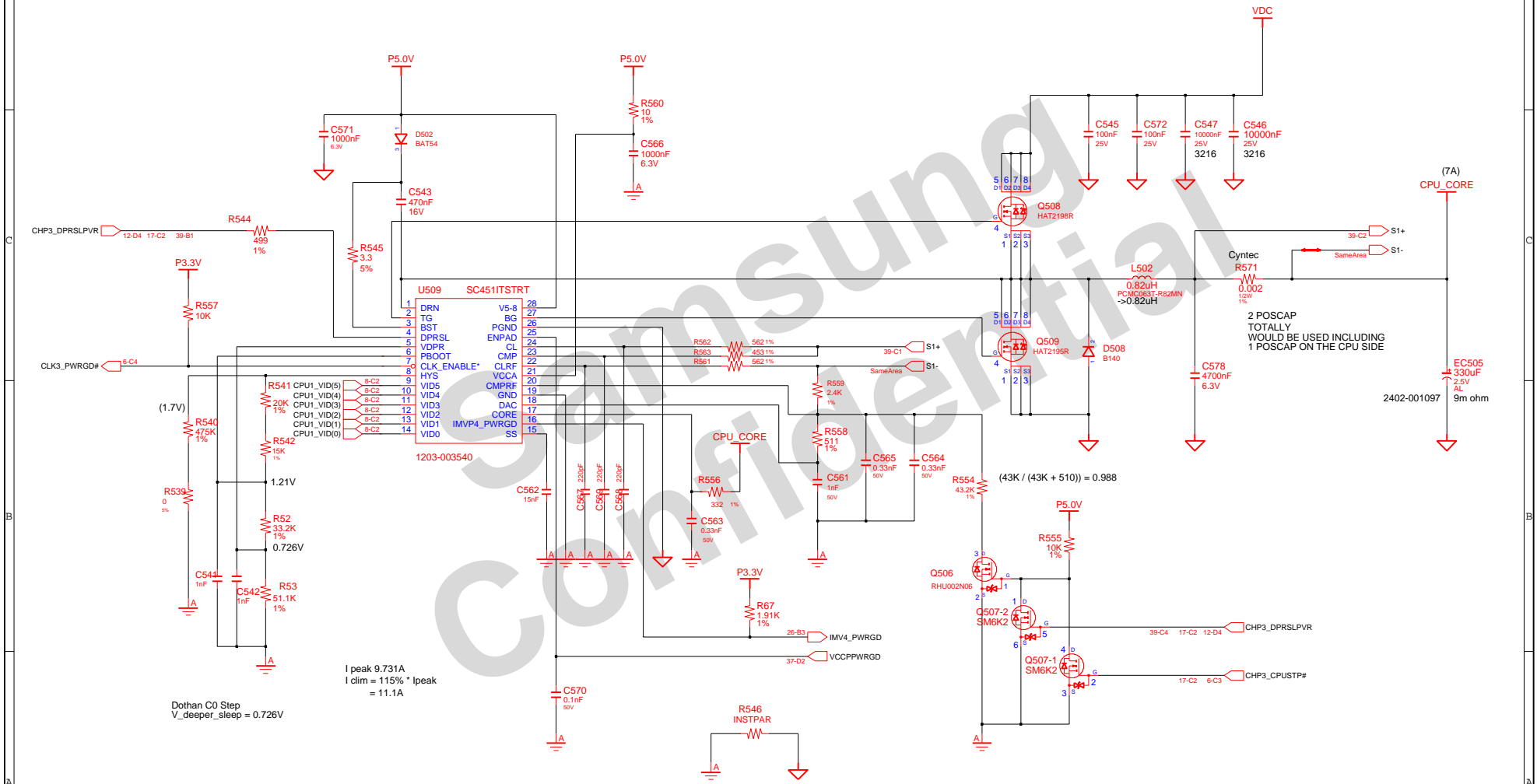

DRAW	KO, W.S.	DATE	3/15/2007	TITLE	Macao MAIN CPU VRM	<b>SAMSUNG</b> ELECTRONICS PART NO. BA41-00743A
CHECK	PARK, H.K.	DEV. STEP	SR			
APPROVAL	EUH, J.S.	REV	1.0			
MODULE CODE		LAST EDIT	March 15, 2007 12:01:15 PM	PAGE	39	OF 47

**SAMSUNG PROPRIETARY**

THIS DOCUMENT CONTAINS CONFIDENTIAL PROPRIETARY INFORMATION THAT IS SAMSUNG ELECTRONICS CO.'S PROPERTY. DO NOT DISCLOSE TO OR DUPLICATE FOR OTHERS EXCEPT AS AUTHORIZED BY SAMSUNG.

**Load Switch Control(P5.0V)**

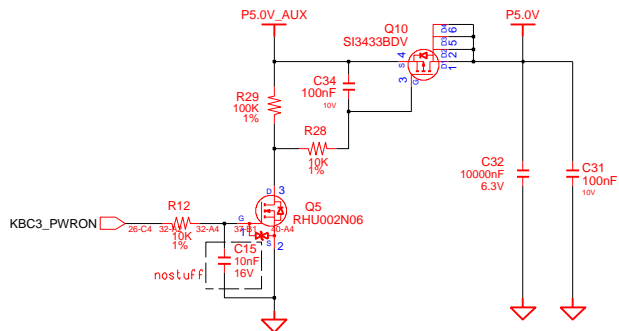

**MICOM RESET**

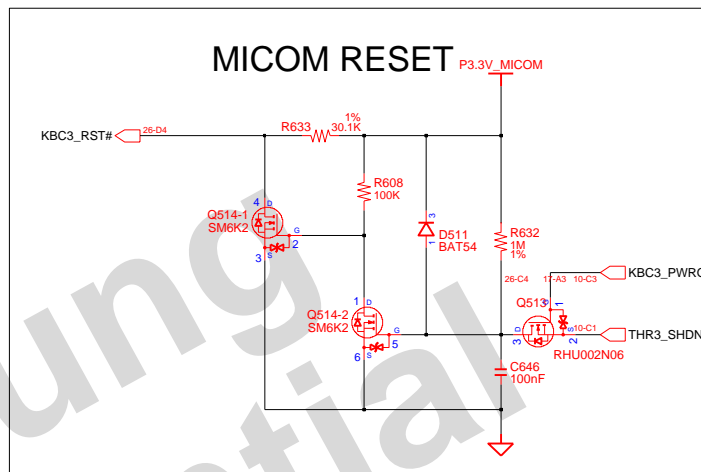

**Load Switch Control(P3.3V)**

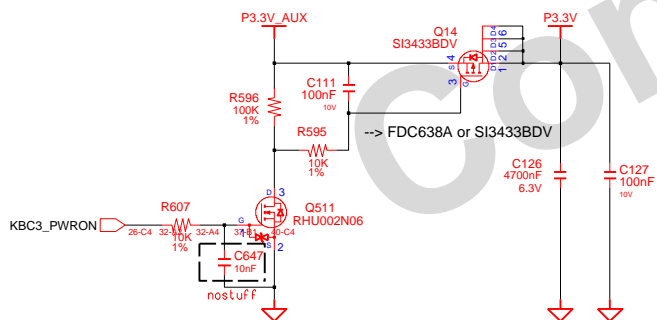

**LDO Power (P2.5V)**

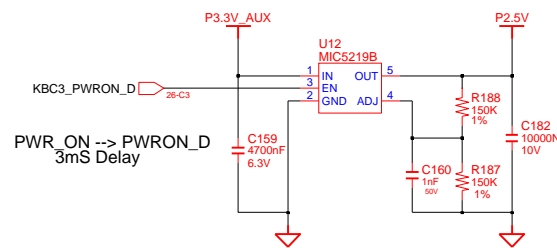

DRAW	KO, W.S.	DATE	3/15/2007	TITLE	Macao MAIN Switched Power	<b>SAMSUNG</b> ELECTRONICS PART NO. BA41-00743A
CHECK	PARK, H.K.	DEV. STEP	SR			
APPROVAL	EUH, J.S.	REV	1.0			
MODULE CODE		LAST EDIT	March 15, 2007 12:01:15 PM	PAGE	40 OF 47	



**SAMSUNG PROPRIETARY**

THIS DOCUMENT CONTAINS CONFIDENTIAL PROPRIETARY INFORMATION THAT IS SAMSUNG ELECTRONICS CO.'S PROPERTY. DO NOT DISCLOSE TO OR DUPLICATE FOR OTHERS EXCEPT AS AUTHORIZED BY SAMSUNG.

PCB REVISION CONTROL (ICT)				
NO	CONNECTION	DATE(Y/M/D)	REVISION	STEP
1	N.C.			
2	1-2			
3	2-3			
4	3-1			
5	1-2-3			
6	N.C.			
7	1-2			
8	2-3			
9	3-1			
10	1-2-3			

REV1  
1 O  
2 O 3

**Main Board Mount Hole**

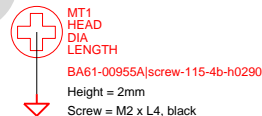
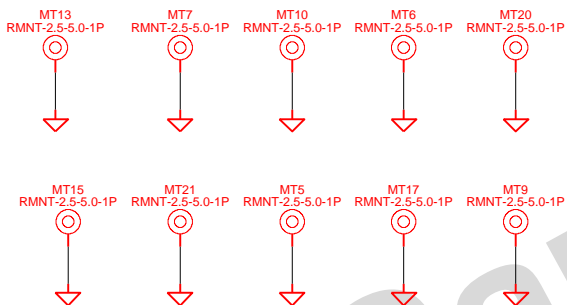

**Mount Hole for LAN sub board**

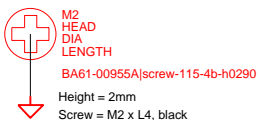

DRAW	KO, W.S.	DATE	3/15/2007	TITLE	Macao	<b>SAMSUNG</b> ELECTRONICS
CHECK	PARK, H.K.	DEV. STEP	SR	MAIN		
APPROVAL	EUH, J.S.	REV	1.0	Mount Hole		PART NO. BA41-00743A
MODULE CODE		LAST EDIT	March 15, 2007 12:01:15 PM	PAGE	41	OF 47

**SAMSUNG PROPRIETARY**

THIS DOCUMENT CONTAINS CONFIDENTIAL PROPRIETARY INFORMATION THAT IS SAMSUNG ELECTRONICS CO.'S PROPERTY. DO NOT DISCLOSE TO OR DUPLICATE FOR OTHERS EXCEPT AS AUTHORIZED BY SAMSUNG.

**LAN Controller (Only 10/100M)**

**LAN Board**  
(Page 42 ~ 44)

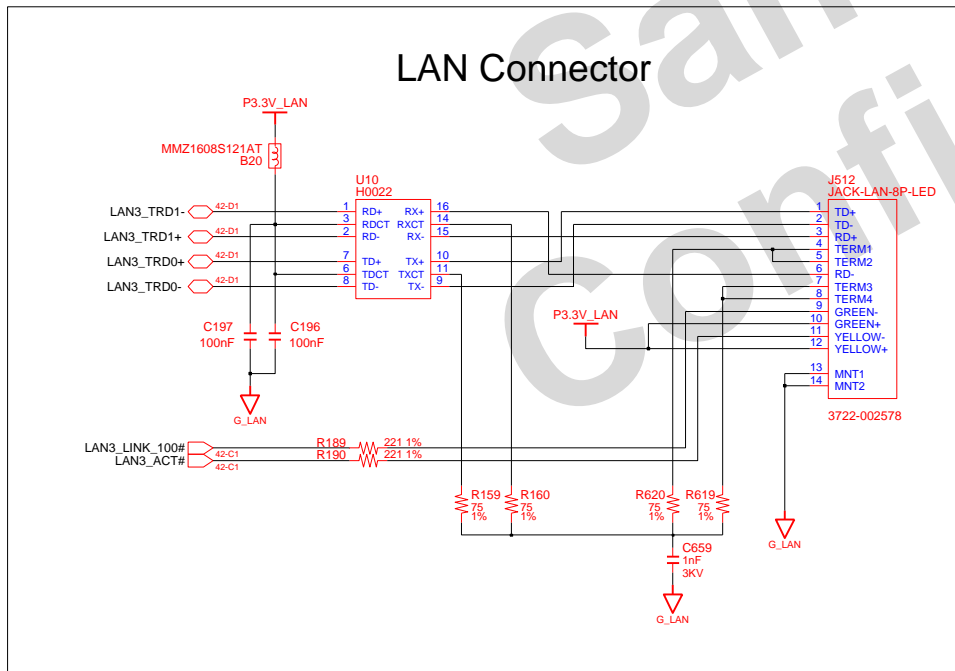
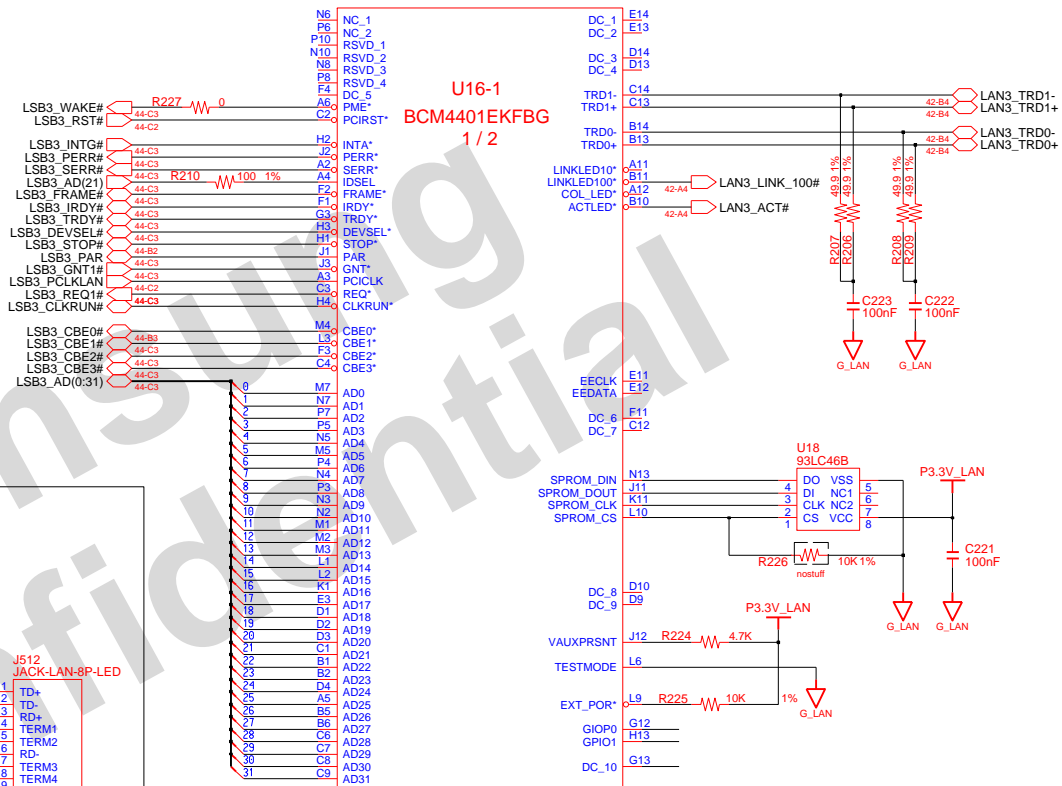

DRAW	KO, W.S.	DATE	3/15/2007	TITLE	Macao	SAMSUNG ELECTRONICS
CHECK	PARK, H.K.	DEV. STEP	SR		LAN B'd	
APPROVAL	EUH, J.S.	REV	1.0		LAN(1/3)	
MODULE CODE		LAST EDIT	March 15, 2007 12:01:15 PM	PAGE	42	OF 47

**SAMSUNG PROPRIETARY**

THIS DOCUMENT CONTAINS CONFIDENTIAL PROPRIETARY INFORMATION THAT IS SAMSUNG ELECTRONICS CO.'S PROPERTY. DO NOT DISCLOSE TO OR DUPLICATE FOR OTHERS EXCEPT AS AUTHORIZED BY SAMSUNG.

# LAN Controller (Only 10/100M)

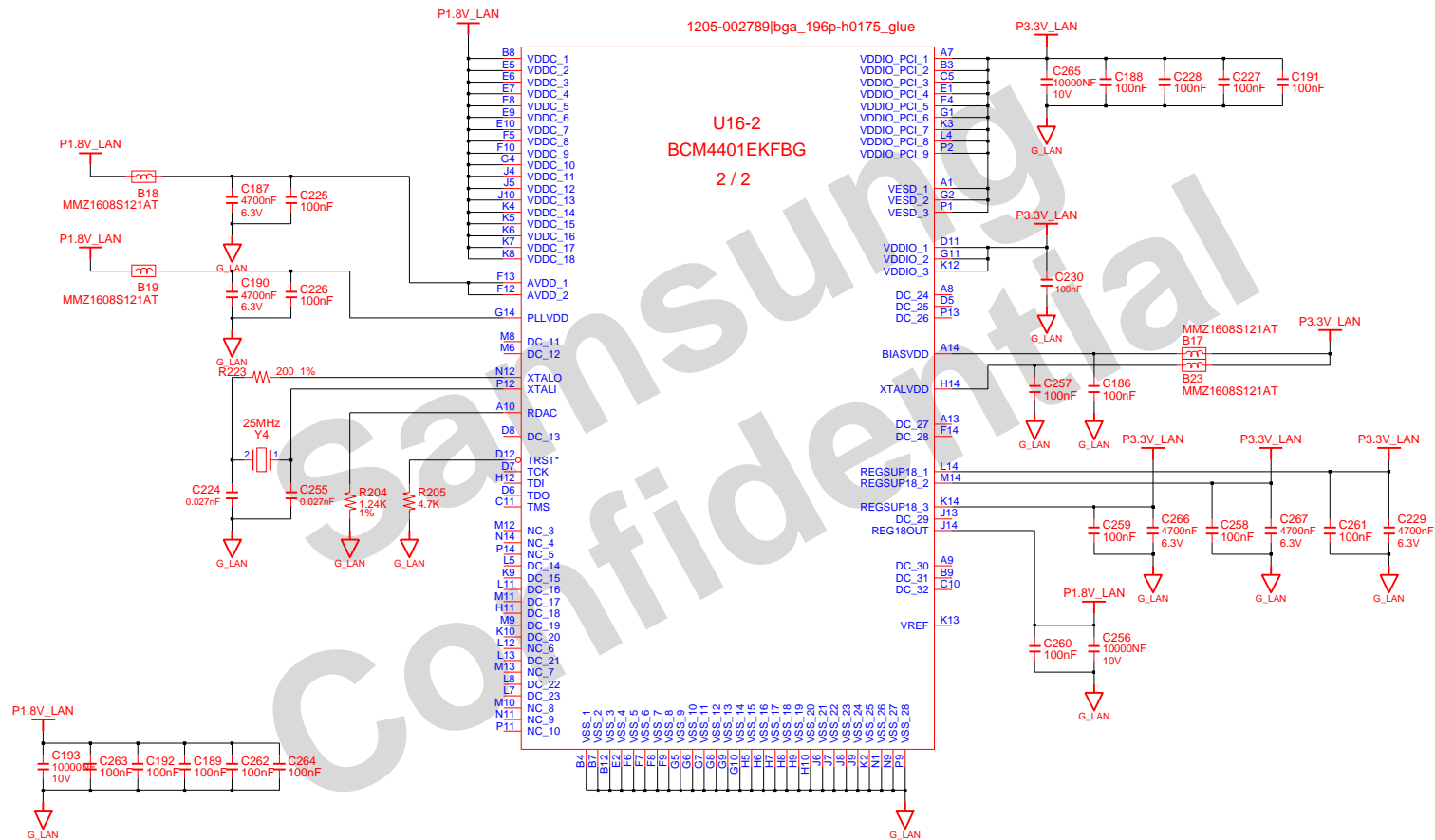

DRAW	KO, W.S.	DATE	3/15/2007	TITLE	Macao LAN B'd LAN(2/3)	<b>SAMSUNG</b> ELECTRONICS PART NO. BA41-00743A
CHECK	PARK, H.K.	DEV. STEP	SR			
APPROVAL	EUH, J.S.	REV	1.0			
MODULE CODE		LAST EDIT	March 15, 2007 12:01:15 PM	PAGE	43 OF 47	

**SAMSUNG PROPRIETARY**

THIS DOCUMENT CONTAINS CONFIDENTIAL  
 PROPRIETARY INFORMATION THAT IS  
 SAMSUNG ELECTRONICS CO.'S PROPERTY.  
 DO NOT DISCLOSE TO OR DUPLICATE FOR OTHERS  
 EXCEPT AS AUTHORIZED BY SAMSUNG.

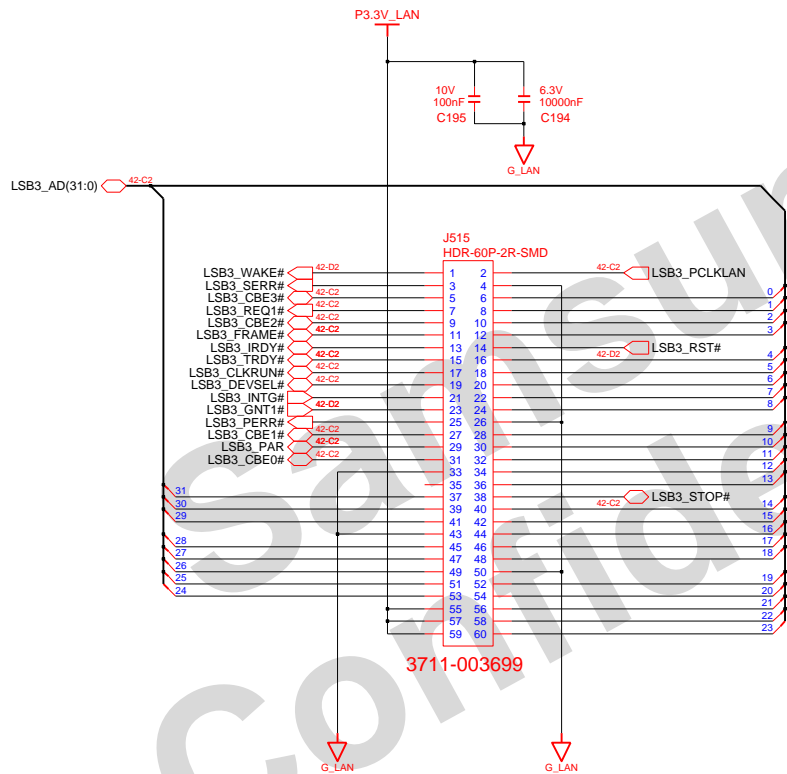

Bottom MT for LAN sub board  
 Screw = 6001-001570, M2xL4 black

DRAW	KO, W.S.	DATE	3/15/2007	TITLE	Macao	SAMSUNG ELECTRONICS
CHECK	PARK, H.K.	DEV. STEP	SR	LAN B'd	LAN(3/3)	
APPROVAL	EUH, J.S.	REV	1.0			PART NO. BA41-00743A
MODULE CODE		LAST EDIT	March 15, 2007 12:01:15 PM	PAGE	44	OF 47

**SAMSUNG PROPRIETARY**

THIS DOCUMENT CONTAINS CONFIDENTIAL PROPRIETARY INFORMATION THAT IS SAMSUNG ELECTRONICS CO.'S PROPERTY. DO NOT DISCLOSE TO OR DUPLICATE FOR OTHERS EXCEPT AS AUTHORIZED BY SAMSUNG.

# SD/MMC Socket Board

## SD/MMC Socket

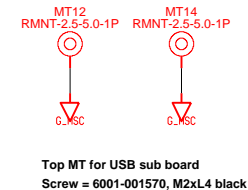
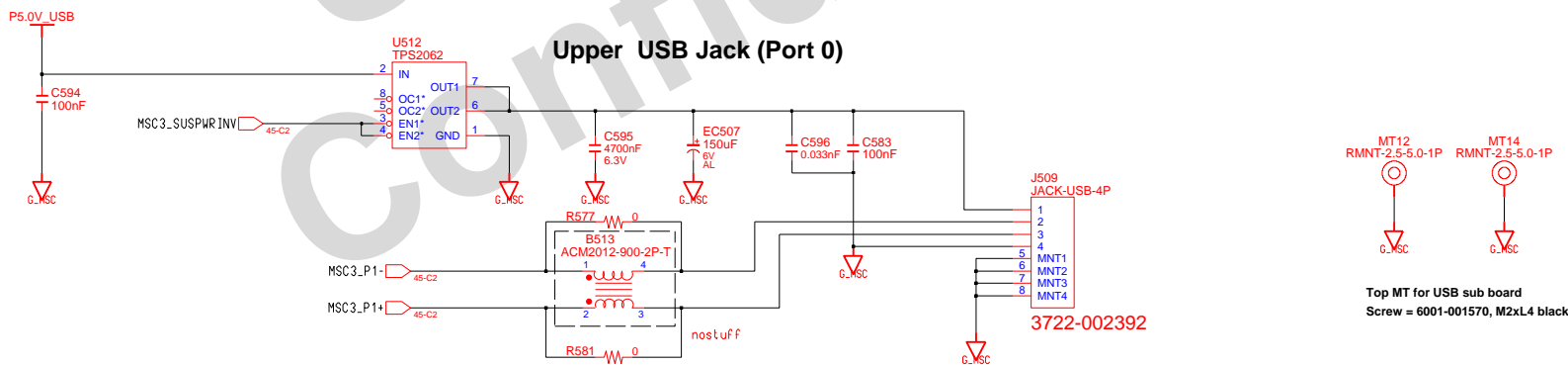
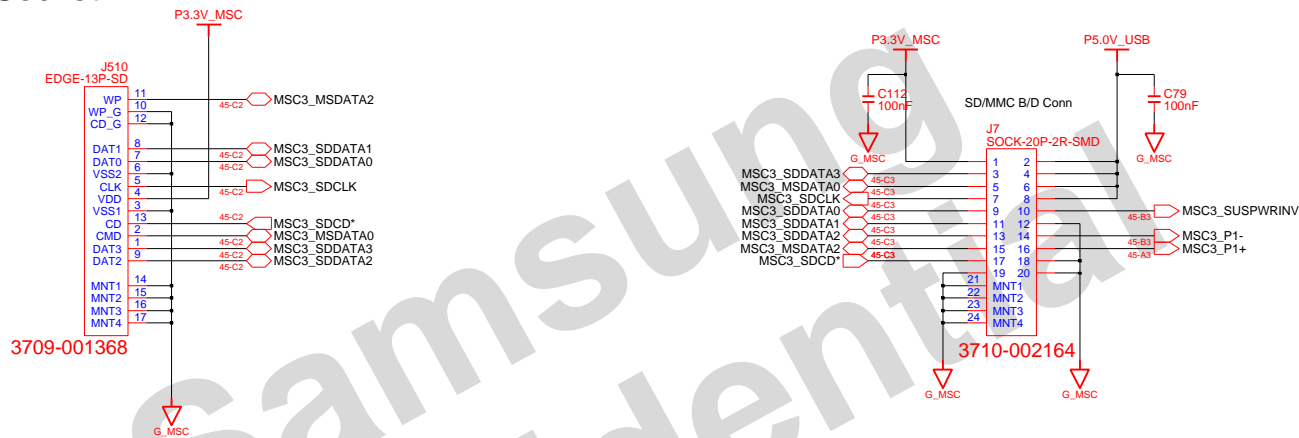

DRAW	KO, W.S.	DATE	3/15/2007	TITLE	Macao	<b>SAMSUNG</b> ELECTRONICS
CHECK	PARK, H.K.	DEV. STEP	SR	SD/MMC Socket B'd		
APPROVAL	EUH, J.S.	REV	1.0	SD/MMC Socket	PART NO.	BA41-00743A
MODULE CODE		LAST EDIT	March 15, 2007 12:01:15 PM	PAGE	45	OF 47

**SAMSUNG PROPRIETARY**

THIS DOCUMENT CONTAINS CONFIDENTIAL PROPRIETARY INFORMATION THAT IS SAMSUNG ELECTRONICS CO.'S PROPERTY. DO NOT DISCLOSE TO OR DUPLICATE FOR OTHERS EXCEPT AS AUTHORIZED BY SAMSUNG.

# Sub Board Left

## Sub Left Board to Main board

## SIM CARD CONN.

## Hall Mouse Conn

## KBD Conn

## Fingerprint Conn

## POWER & HOLD S/W

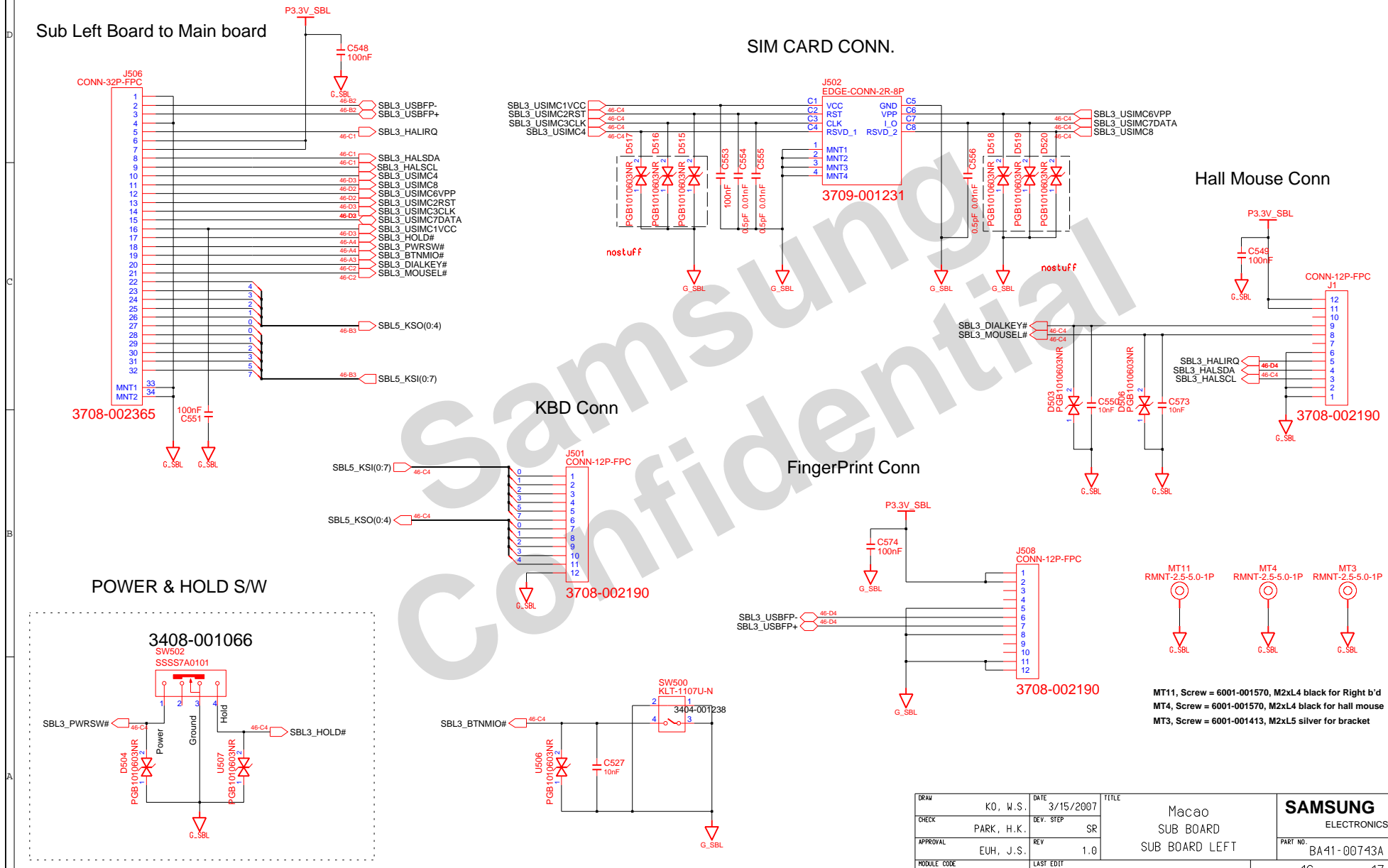

MT11, Screw = 6001-001570, M2xL4 black for Right b'd  
 MT4, Screw = 6001-001570, M2xL4 black for hall mouse  
 MT3, Screw = 6001-001413, M2xL5 silver for bracket

DRAW	KO, W.S.	DATE	3/15/2007	TITLE	Macao SUB BOARD SUB BOARD LEFT	<b>SAMSUNG</b> ELECTRONICS
CHECK	PARK, H.K.	DEV. STEP	SR	REV	1.0	
APPROVAL	EUH, J.S.	LAST EDIT	March 15, 2007 12:01:15 PM	PAGE	46	OF 47
MODULE CODE						BA41-00743A

**SAMSUNG PROPRIETARY**

THIS DOCUMENT CONTAINS CONFIDENTIAL PROPRIETARY INFORMATION THAT IS SAMSUNG ELECTRONICS CO.'S PROPERTY. DO NOT DISCLOSE TO OR DUPLICATE FOR OTHERS EXCEPT AS AUTHORIZED BY SAMSUNG.

# Finger Print Sub Board

Recommend value  
2.2ohm -> 1.8ohm

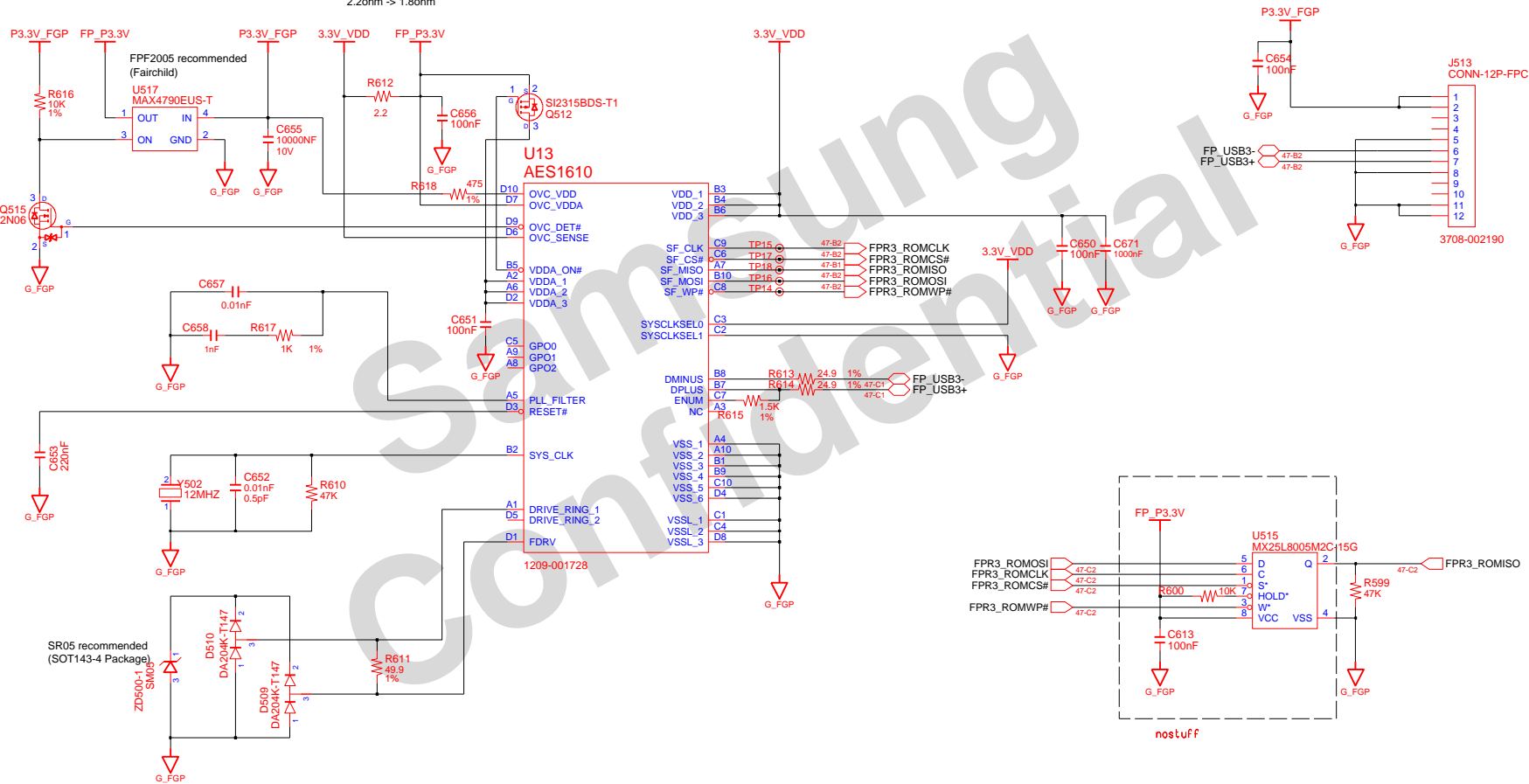

DRAW	KO, W.S.	DATE	3/15/2007	TITLE	Macao SUB BOARD FINGERPRINT	<b>SAMSUNG</b> ELECTRONICS PART NO. BA41-00743A
CHECK	PARK, H.K.	DEV. STEP	SR			
APPROVAL	EUH, J.S.	REV	1.0			
MODULE CODE		LAST EDIT	March 15, 2007 12:01:15 PM	PAGE	47 OF 47	