

1.5A DDR Termination Regulator

DESCRIPTION

The EUP7996 is a high performance linear regulator designed to provide power for termination of a DDR memory bus. It significantly reduces parts count, board space and overall system cost over previous switching solutions.

The EUP7996 contains a high-speed operational amplifier to provide excellent response to load transients. The EUP7996 also incorporates a V_{SENSE} pin to provide superior load regulation and a V_{REF} output as a reference for chipset and DIMMs.

An additional feature found on the EUP7996 is an active low shutdown (SD) pin. When SD is pulled low the V_{TT} output will Tri-state providing a high impedance output, but, V_{REF} will remain active. A power savings advantage can be obtained in this mode through lower quiescent current.

The EUP7996, used in conjunction with series termination resistors, provides an excellent voltage source for active termination schemes of high speed transmission lines as those seen in high speed memory buses. A typical DDR memory system is seen in Figure 1.

FEATURES

- Extremely low quiescent current (305uA)
- Fast transient response time
- Capable of sourcing and sinking 1.5A for DDR-I termination
- Reference out for other memory and control components
- Low-current shutdown mode
- Over-temperature protection
- High accuracy output voltage at full-load
- Low external component count
- Available in SOP-8, SOP(FD) package
- RoHS compliant and 100% lead (Pb)-free

APPLICATIONS

- DDR-I and DDR-II termination voltage

SIMPLIFIED SYSTEM DIRGRAM

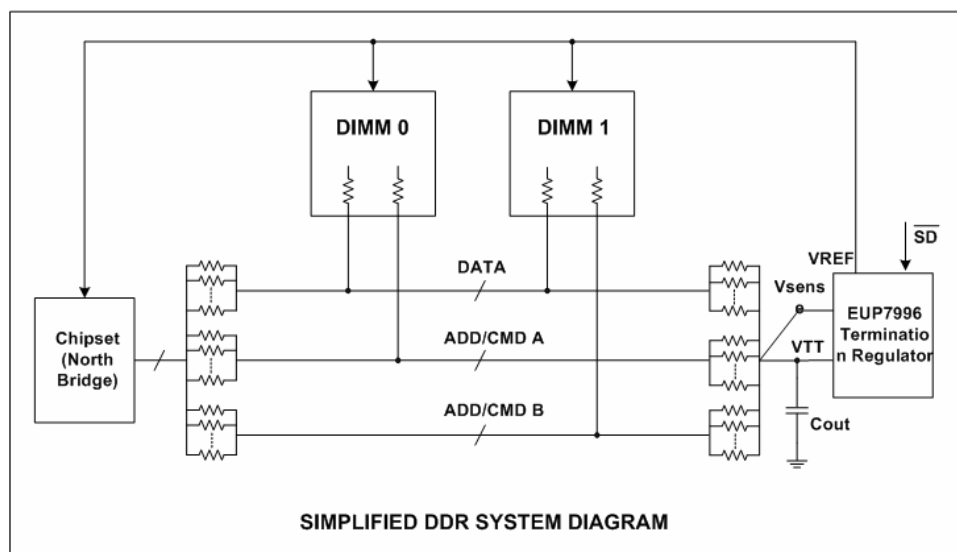

Figure 1.

Pin Configurations

Package Type	Pin Configurations (TOP VIEW)
Plastic SOP-8(FD)* * Thermal Pad	

Pin Description

PIN	SYMBOL	DESCRIPTION
1	GND	Ground
2	SD	Shutdown
3	VSENSE	Feedback pin for regulating V_{TT}
4	VREF	Buffered internal reference voltage of $V_{DDQ}/2$
5	VDDQ	Input for internal reference equal to $V_{DDQ}/2$
6	AVIN	Analog input pin
7	PVIN	Power Input pin
8	VTT	Output voltage for connection to termination resistors

Typical Application Circuit

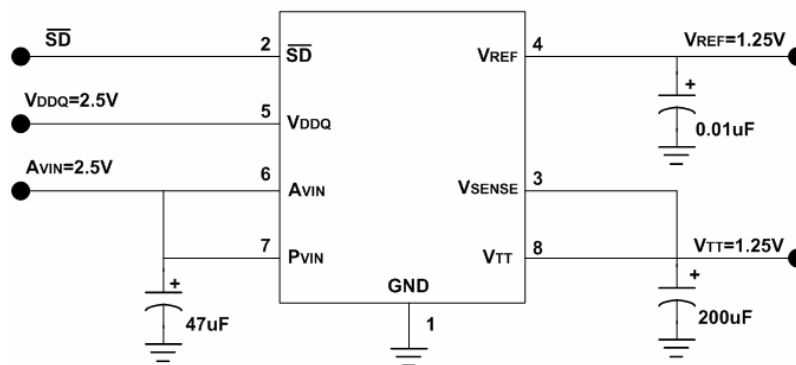

Figure 2. Recommended DDR-I Termination

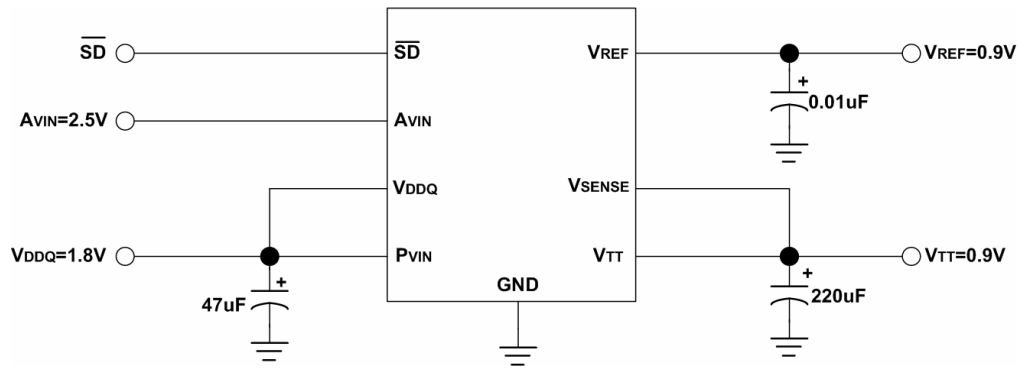

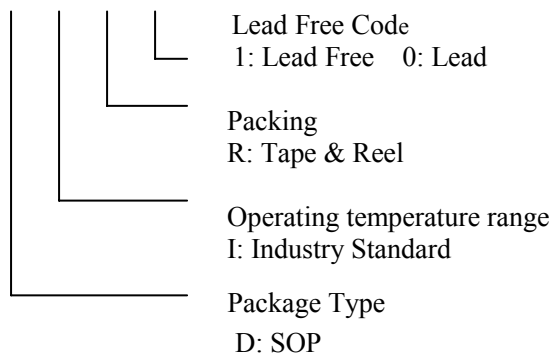

Figure 3. Recommended DDR-II Termination

Ordering Information

Order Number	Package Type	Marking	Operating Temperature range
EUP7996ADIR1	SOP-8	 Xxxx EUP7996 A	-40 °C to 125°C
EUP7996ADIR0	SOP-8	 Xxxx EUP7996 A	-40 °C to 125°C

EUP7996A



Absolute Maximum Ratings

Input voltage	-----	6V
Power dissipation	-----	Internal limiting
ESD rating	-----	3KV
Maximum junction temperature	-----	150 °C
Storage temperature range	-----	-65°C to 150°C
Lead temperature (soldering , 5 sec)	--	260 °C
SOP-8 thermal resistance, jA	-----	67.9 °C/W
SOP-8(FD) thermal resistance, jA	----	42.3 °C/W

Operating Range

Junction Temp. Range	-----	-40°C to 125°C
AVIN to GND	-----	-1.8V to 5.5V
PVIN, VDDQ to GND	-----	-1.8V to AVIN
SD Input Voltage	-----	0 to AVIN

Electrical Characteristics

Specifications with standard typeface are for $T_A=25\text{ }^\circ\text{C}$, unless otherwise specified, $AVIN=2.5V$

Symbol	Parameter	Conditions	Min	Typ	Max	Units
V_{REF}	V_{REF} Voltage	$I_{REF}=0mA$ PVIN=VDDQ=2.5V PVIN=VDDQ=1.8V	1.235 0.886	1.242 0.899	1.285 0.914	V
V_{TT}	V_{TT} Output Voltage	PVIN=VDDQ=2.5V $I_{OUT}=0A$ $I_{OUT}=\pm 1.5A$	1.225 1.225	1.251 1.251	1.290 1.290	V
		PVIN=VDDQ=1.8V $I_{OUT}=0A$ $I_{OUT}=\pm 0.9A$	0.885 0.885	0.892 0.892	0.915 0.915	V
V_{OS}	Output Offset Voltage	PVIN=VDDQ=2.5V $I_{OUT}=0A$ $I_{OUT}=-1.5A$ $I_{OUT}=+1.5A$	-20 -25 -25	0 0 0	20 25 25	mV
		PVIN=VDDQ=1.8V $I_{OUT}=0A$ $I_{OUT}=-1A$ $I_{OUT}=+0.9A$	-15 -20 -20	0 0 0	15 20 20	mV
I_Q	Quiescent Current (Note 2)	$I_{OUT}=0A$	200	305	500	μA
I_{SHDN}	Quiescent Current in Shutdown	SD = 0V	50	75	200	μA
I_{LKG_SD}	Shutdown leakage current	SD = 0V	--	0.16	--	μA
I_V	V_{TT} Leakage Current in Shutdown	SD = 0V, $V_{TT} = 1.25V$	--	0.13	--	μA

Over Temperature Protection

T_{SD}	Thermal Shutdown Temperature	Guaranteed by design	--	155	--	$^\circ C$
T_{SD_HYS}	Thermal Shutdown Hysteresis	Guaranteed by design	--	30	--	$^\circ C$

Shutdown function

V_{IH}	Shutdown Threshold Trigger	Output = High	1.8	--	--	V
V_{IL}		Output = Low	--	--	0.6	

Note 1: V_{OS} offset is the voltage measurement defined as V_{TT} subtracted from V_{REF} .

Note 2: Quiescent current defined as the current flow into AVIN.

Typical Performance Characteristics

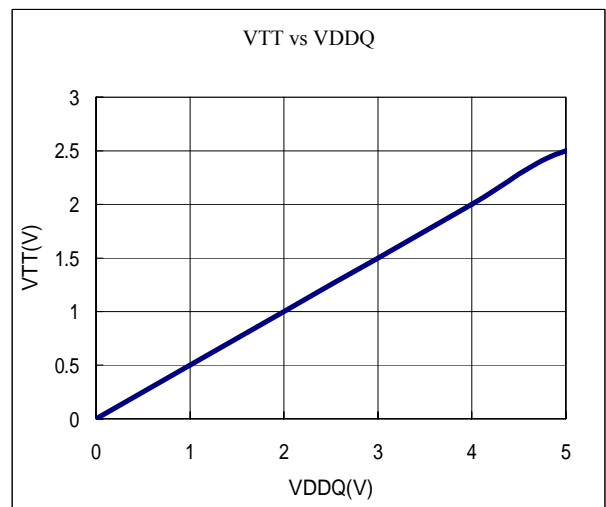
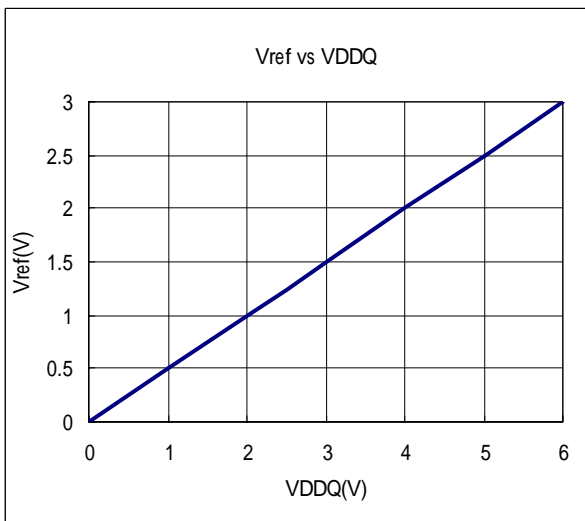
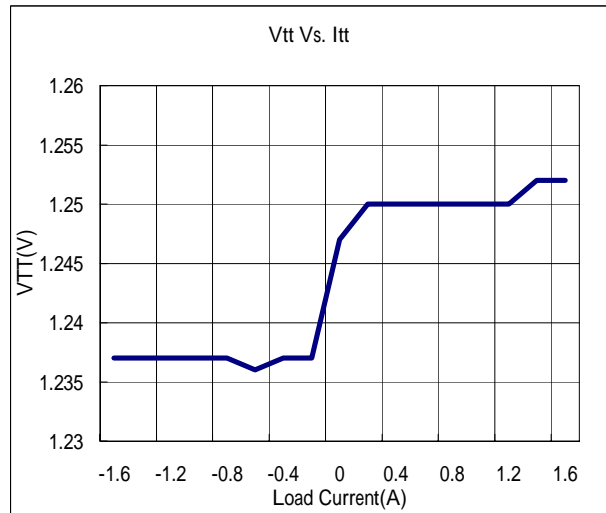
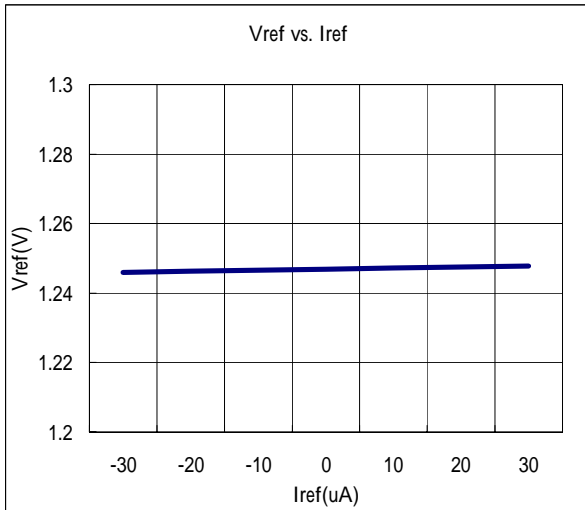
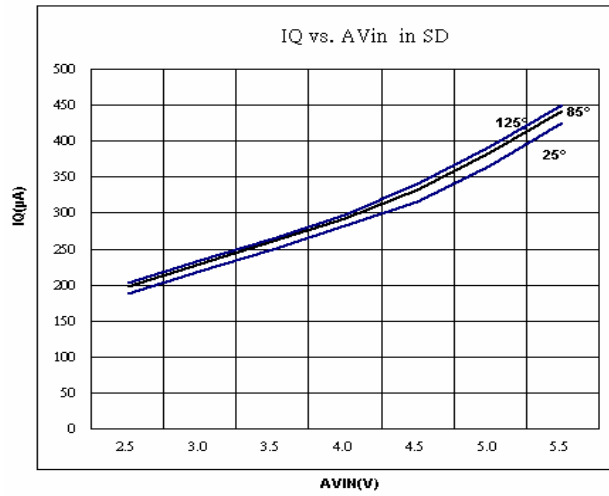
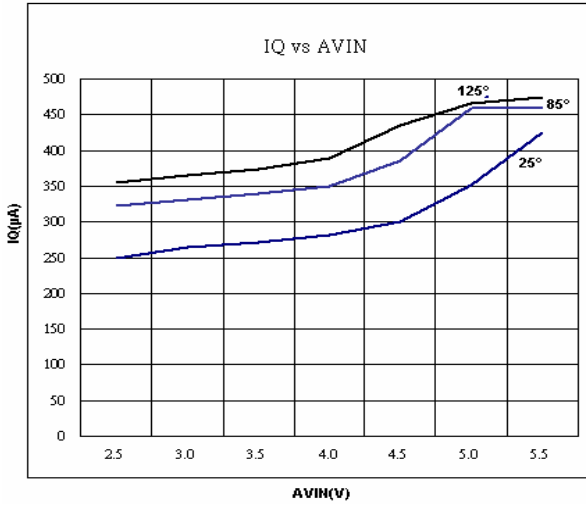

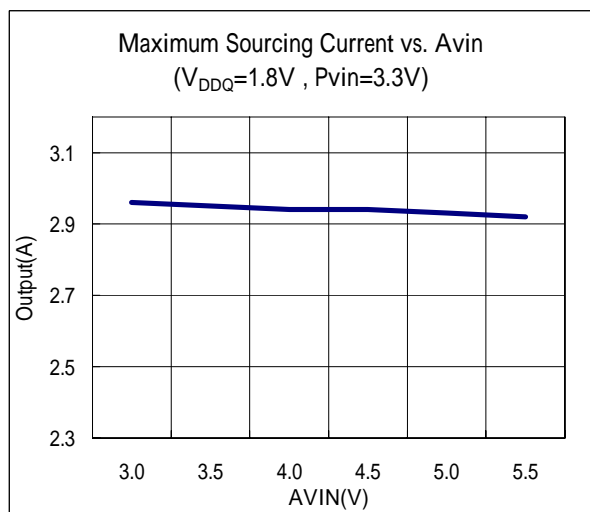
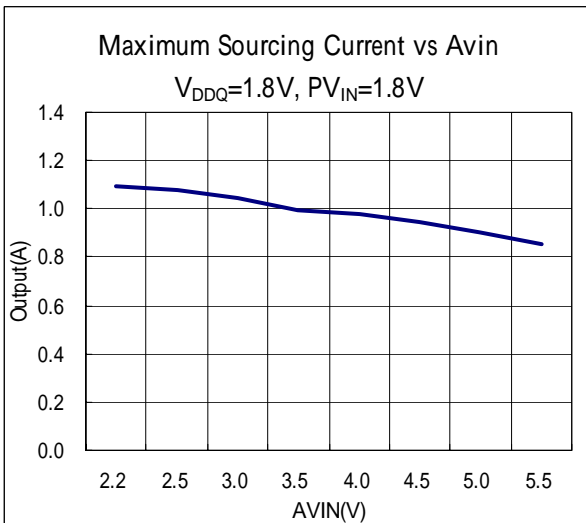
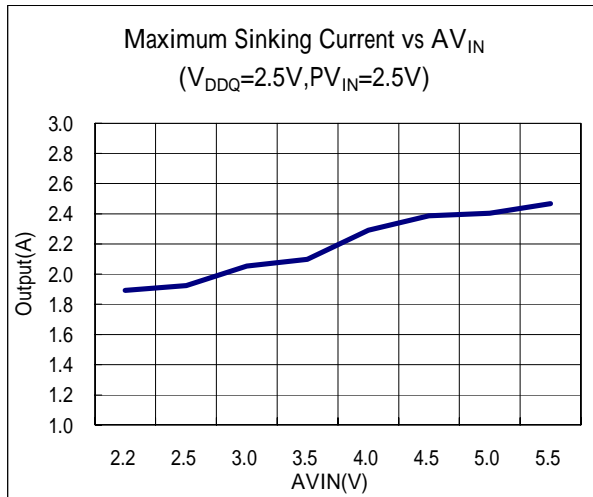
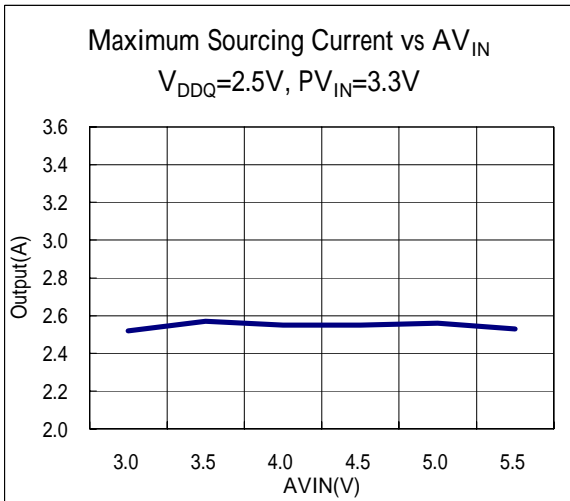
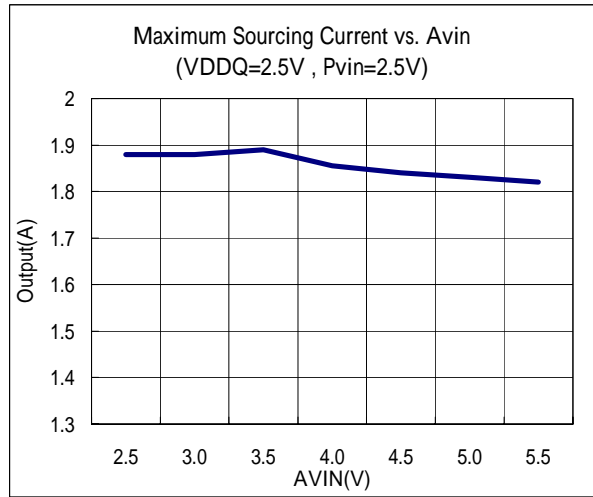
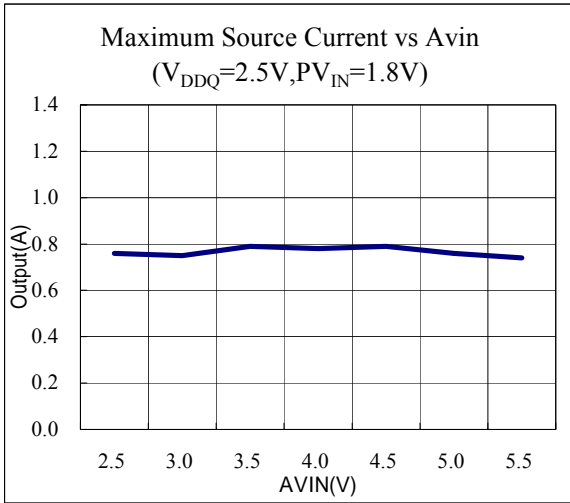

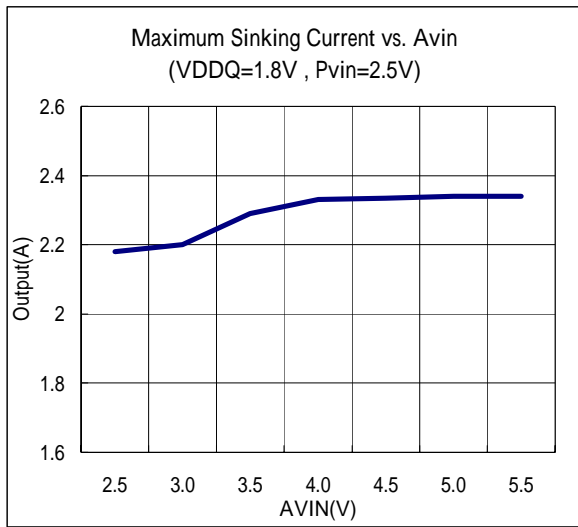

1.25Vtt Transient Response
AVIN==PVIN=VDDQ=2.5V Cour=330uF/16V

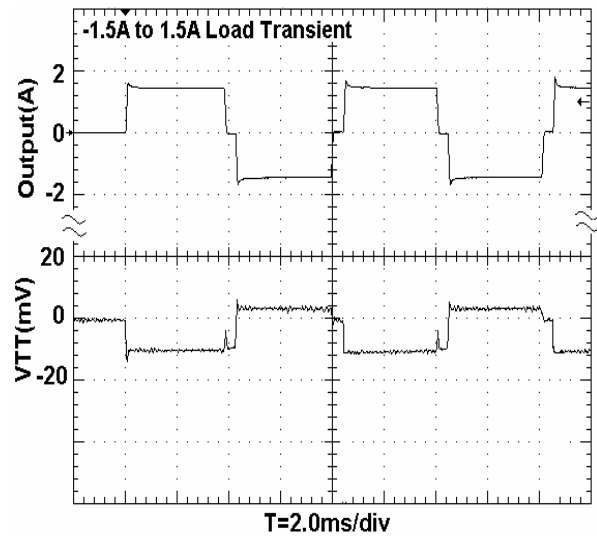

0.9Vtt Transient Response
AVIN=2.5V, PVIN=VDDQ=1.8V Cour=330uF/16V

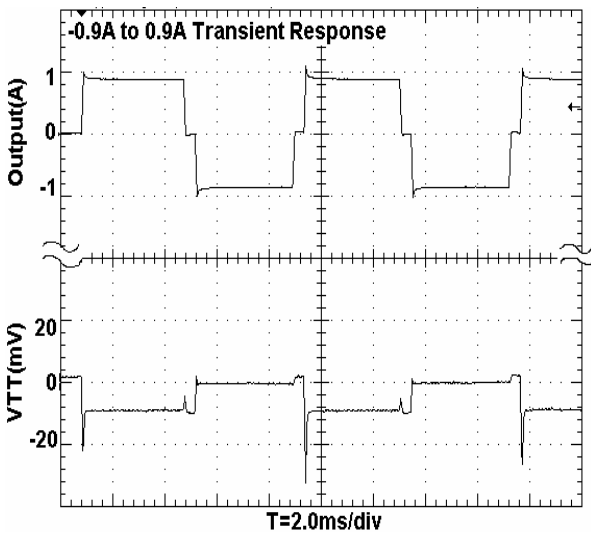

Block Diagram

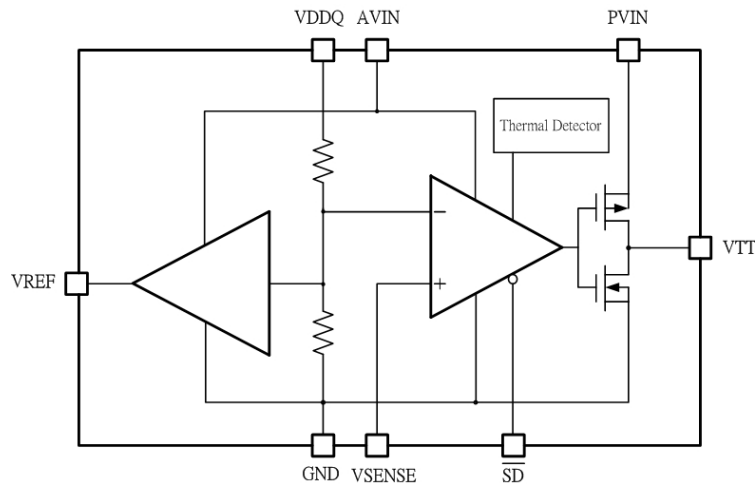

Pin Functions

AVIN and PVIN

AVIN and PVIN are the input supply pins for the EUP7996. AVIN is used to supply the internal control circuitry. PVIN, however, is used exclusively to provide the rail voltage for the output stage used to create V_{TT} . For SSTL-2 application, a good compromise would be to connect the AVIN and PVIN directly together at 2.5V. This eliminates the need for bypassing the two supply pins separately. For SSTL-18 applications, it is recommended to connect PVIN to 1.8V rail used for the memory core and AVIN to a rail typically 2.5V supply. The only limitation on input voltage selection is that PVIN must be equal to or lower than AVIN.

VDDQ

VDDQ is the input used to create the internal reference voltage for regulating V_{TT} . The reference voltage is generated from a resistor divider of two internal 50K Ω resistors. This guarantees that V_{TT} will track VDDQ/2 precisely. For SSTL-2 applications, VDDQ should be a 2.5V. The optimal implementation of VDDQ is as remote sense. This can be achieved by connecting VDDQ directly to the 2.5V rail at DIMM instead of AVIN and PVIN. This ensures that the reference voltage tracks the DDR memory rails precisely without a large voltage drop from the power lines. For SSTL-18 applications, VDDQ will be a 1.8V signal.

VSENSE

The purpose of the sense pin is to provide improved remote load regulation. In most motherboard application the termination resistors will connect to V_{TT} in a long plane. The V_{SENSE} pin can be used by connecting it to the middle of the bus. This will provide a better distribution across the entire termination bus. When remote sense is used, it may necessary to put a 0.1uF ceramic capacitor beside the V_{SENSE} pin to eliminate the noise that coupled to V_{SENSE} due to the long trace. V_{SENSE} pin must be connected to V_{TT} if remote load regulation is not used.

VREF

V_{REF} provides the buffered output of the internal reference voltage VDDQ/2. This output should be used to provide the reference voltage for the Northbridge chipset and memory. Since these inputs are typically extremely high impedance, there should be little current drawn from V_{REF} . For improved performance, an output bypass capacitor can be used, located close to the pin, to help with noise. A ceramic capacitor in the range of 0.01uF to 0.1uF is recommended. This output remains active during the shutdown state and thermal shutdown events.

VTT

V_{TT} is a regulated output that is used to terminate the bus resistors. It is capable of sinking and sourcing current while regulating the output precisely to VDDQ/2. The EUP7996 is capable of sinking and sourcing 1.5A continuous current. If a transient above the maximum continuous current is expected for a significant amount of time then the output capacitor should be sized large enough to prevent an excessive voltage drop. If large current are required for longer duration, then care should be taken to ensure that the maximum junction temperature is not exceeded. If the junction temperature exceeds the thermal shutdown point than V_{TT} will tri-state until the part returns below the hysteretic trip-point.

SD

SD can be used to put the regulator into low-power mode. When SD is pulled low, the V_{TT} power amplifier is turned off and the V_{TT} output is tri-state, but, V_{REF} will remain active, allowing those circuits requiring a reference during the standby state to remain active.

Component Selection

INPUT CAPACITOR

The input capacitor should be located as close as possible to the PVIN pin. Several recommendations exist dependent on the application required. A typical value recommended for AL electrolytic capacitors is 47 μ F. If the two supply rails (AVIN and PVIN) are separated then the 47 μ F capacitor should be placed as close to possible to PVIN rail. An additional 0.1 μ F ceramic capacitor can be placed on the AVIN rail to prevent excessive noise from coupling into the device.

OUTPUT CAPACITOR

As general recommendation, the output capacitor should be sized above 220 μ F with a low ESR for SSTL applications with DDR-SDRAM. The value of ESR should be determined by maximum current spikes expected from the DDR memory system to ensure V_{TT} staying within ± 40 mV of V_{REF} . Capacitor selection can be varied depending on the number of lines terminated and the maximum load transient.

With motherboards and other applications where V_{TT} is distributed across a long plane it is advisable to use multiple bulk capacitors. Large aluminum electrolytic capacitors can be used for their low ESR and low cost. Additional 0.1 μ F ceramic capacitor is needed for high frequency decoupling.

When size and performance are critical, several hybrid capacitors such OS-CON and SP that offer a large capacitance while maintaining a low ESR are the better solution.

PCB Layout Considerations

The EUP7996 regulator is packaged in plastic SOP-8 package. This small footprint package is unable to convectively dissipate at high current levels. The junction temperature should be kept well away from the thermal shutdown temperature in normal operation. To prevent damaging the part from exceeding the maximum allowable junction temperature, care should be taken to derate the part dependent on several variables: the thickness of copper on PCB; the area of top side copper used; and the airflow. Using large traces and more copper on the top side of board with careful layout are possible to reduce thermal resistance on the part.

If the large ground trace around the IC is unavailable on top, numerous vias to connect the part and dissipate heat to the internal ground plane will help. The vias should be small enough to retain solder when the board is wave-soldered.

Additional improvements can be achieved with a constant airflow across the package.

Test Circuit

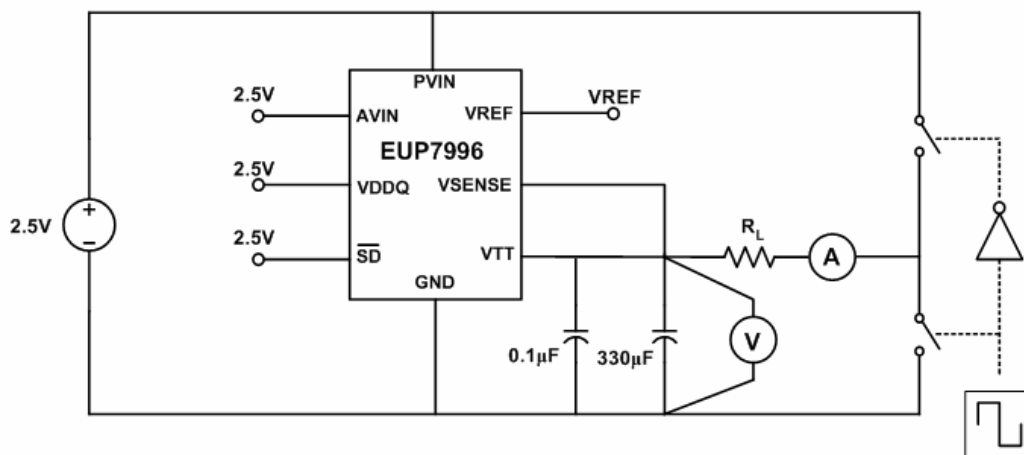
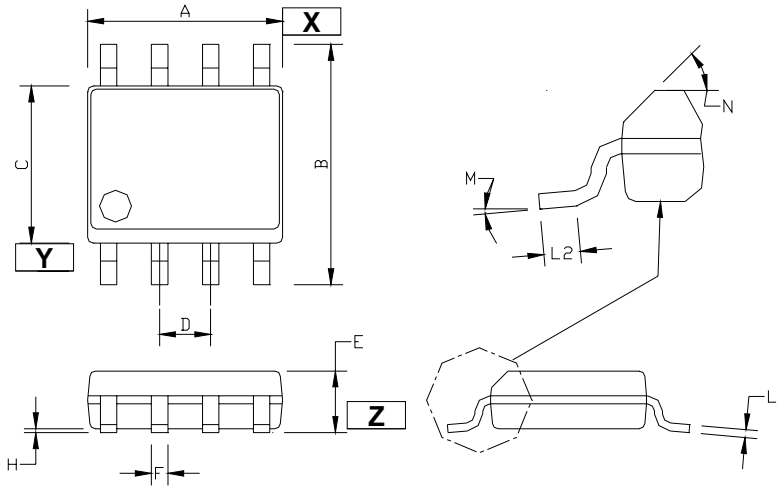
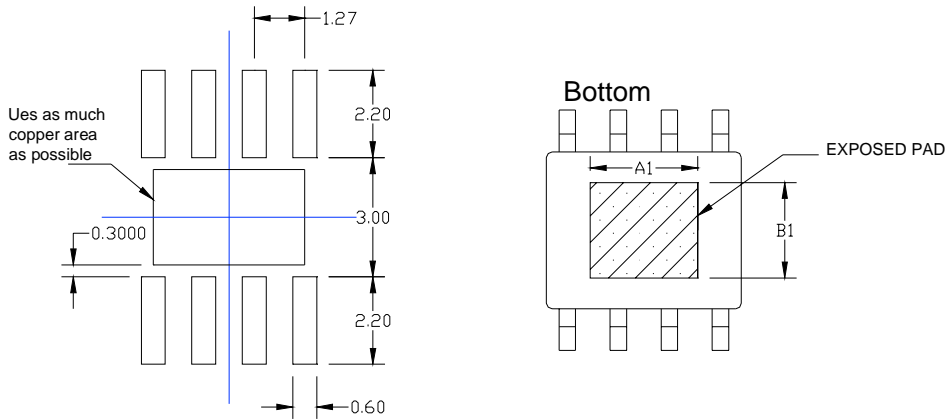

Figure 2. Load transient (+1.5A ~ -1.5A) test circuit

Mechanical Information



Standard Solder Map



Symbols	Dimension in Millimeters		Dimension in Inches	
	Min.	Max.	Min.	Max.
A	4.80	5.00	0.189	0.197
B	5.80	6.20	0.228	0.244
C	3.80	4.00	0.150	0.157
D	1.194	1.346	0.047	0.053
E	1.45	1.55	0.057	0.061
H	0.00	0.10	0.000	0.004
F	0.33	0.51	0.013	0.020
L1	0.19	0.25	0.007	0.010
L2	0.40	1.27	0.016	0.050
M	0°	8°	0°	8°
N	40°	50°	40°	50°
A1	2.6	2.8	0.102	0.110
B1	2.4	2.6	0.095	0.102

8 – Lead SOP(FD) Plastic Package